



ET90

Tracked Conventional Excavator

The economic powerhouse

The fuel consumption of the ET90 is up to 20 percent lower than with comparable models – this reduces the operating costs significantly. At the same time, it produces outstanding results in applications with an excellent engine and hydraulic performance. This efficient combination provides for first-class digging power with up to 20 percent more bucket breakout force. Conversely, the economical load sensing hydraulic system allows for very precise lifting arm movements with full output at the same time. Whether power or precision, the ET90 is exactly the right 9-ton excavator for any application.

Highlights

- Powerful drive system with LUDV
- Triple boom
- 3-point kinematics
- More cab comfort
- Up to four additional factory-installed control circuits

Technical Data

Hydraulic

Operating pressure	300.0 bar
hydraulikpump	Variable displacement pump
Flow rate	176.0 l/min
Flow rate max.	180.0 l/min
Tank capacity	92.0 l

Mechanical - Output Details

Travel speed	5.0 km/h
--------------	----------

Mechanical Details

Length	7,139.0 mm
Width	2,250.0 mm
Height	2,562.0 mm
Operating weight (min.-max.)	8,710.0 - 10,506.0 kg
Digging depth (max.)	4,679.0 mm

Engine

Cooling	Water-cooling
Motor type	Diesel engine
Cylinder	4.0
Cylinder capacity	2,799.0 cm ³

Inclined position max.	30.0 °
Fuel type	Diesel EN 590
Tank capacity	85.0 l
Effective power	55.4 KW
Nominal Engine speed	2,300.0 1/min
Operating power	55.4 KW
Operating Engine speed	2,400.0 1/min
Battery capacity (nom. value)	88.0 Ah
Manufacturer	Perkins
Engine designation	904J-E28T

Environment Data

Protection class	Stage V
Sound level LpA	99.0 dB(A)
Sound power LWA, guaranteed	99.0 dB(A)

Chassis

Operating pressure	240.0 bar
--------------------	-----------

Shipping and Storage

Shipping weight	8,348.0 kg
-----------------	------------

Dimensions

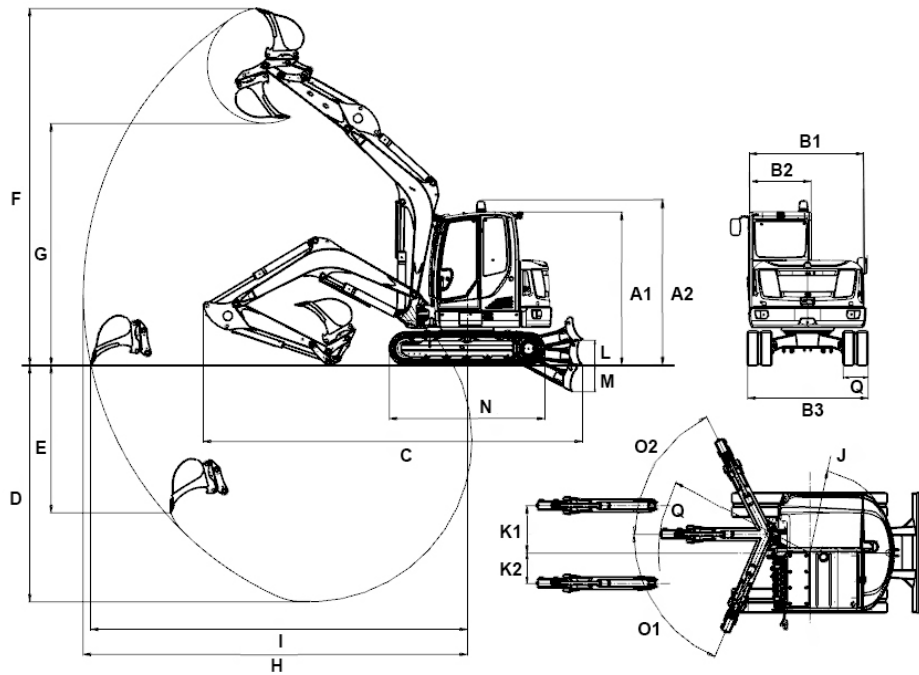

A1	Height with cab	2,562 mm
	Height of dozer blade	501 mm
A2	Total height with rotating beacon	2,744 mm
B1	Width of upper carriage	2,006.9 mm
B2	Width of cab	1,000 mm
B3	Width travel gear	2,250 mm
B4	Width of dozer blade	2,250 mm
C	Transport length short shovel arm	7,117 mm
	Transport length long shovel arm	7,139 mm
D	Digging depth max., short shovel arm	4,325 mm
	Digging depth max., long shovel arm	4,625 mm
E	Piercing depth max., short shovel arm	3,192 mm
	Piercing depth max., long shovel arm	3,474 mm
F	Piercing height max., short shovel arm	7,322 mm
	Piercing height max., long shovel arm	7,529 mm
G	Dumping height max., short shovel arm	5,066 mm
	Dumping height max., long shovel arm	5,272 mm
H	Digging radius max., short shovel arm	7,331 mm
	Digging radius max., long shovel arm	7,620 mm
I	Max. reach at ground level (short shovel arm)	7,179 mm
	Max. reach at ground level (long shovel arm)	7,474 mm
J	Tail swing radius	1,583 mm
	Tail swing radius with tail weight	1,655 mm
K1	Boom offset max. (to center of bucket right side)	705 mm
K2	Boom offset max. (to center of bucket left side)	683 mm
L	Stacking height max. (dozer blade above surface)	479 mm
M	Digging depth max. (dozer blade below surface)	518 mm
N	Length travel drive	2,826 mm
O1	Max. swivel angle (arm system to the left)	67 °
O2	Max. swivel angle (arm system to the right)	63 °
	Track width	450 mm
Q	Boom swing radius center	2,503 mm
	Boom swing radius right	2,427 mm
	Boom swing radius left	1,969 mm