

WOODS REAR BLADES

RB990-2
RB1010-2

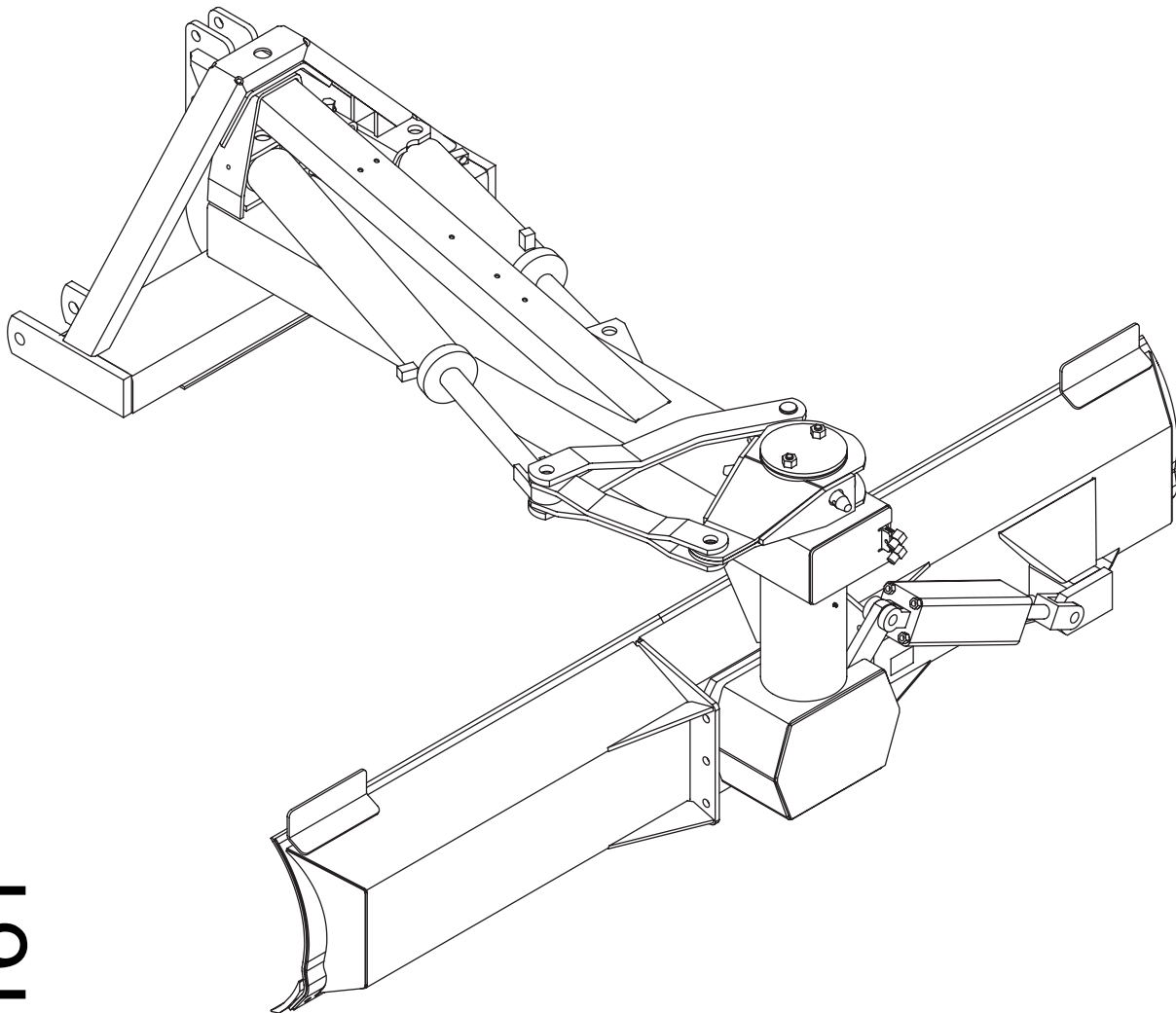

MAN0161

Rev. 9/16/2005

WOODS[®]
Tested. Proven. Unbeatable.

OPERATOR'S MANUAL

TO THE DEALER:

Assembly and proper installation of this product is the responsibility of the Woods® dealer. Read manual instructions and safety rules. Make sure all items on the Dealer's Pre-Delivery and Delivery Check Lists in the Operator's Manual are completed before releasing equipment to the owner.

The dealer must complete the Product Registration included with the Operator's Manual. The customer must sign the registration which certifies that all Dealer Check List items have been completed. The dealer is to return the prepaid postage portion to Woods, give one copy to the customer, and retain one copy. **Failure to complete and return this card does not diminish customer's warranty rights.**

TO THE OWNER:

Read this manual before operating your Woods equipment. The information presented will prepare you to do a better and safer job. Keep this manual handy for ready reference. Require all operators to read this manual carefully and become acquainted with all adjustment and operating procedures before attempting to operate. Replacement manuals can be obtained from your dealer. To locate your nearest dealer, check the Dealer Locator at www.WoodsEquipment.com, or in the United States and Canada call 1-800-319-6637.

The equipment you have purchased has been carefully engineered and manufactured to provide dependable and satisfactory use. Like all mechanical products, it will require cleaning and upkeep. Lubricate the unit as specified. Observe all safety information in this manual and safety decals on the equipment.

For service, your authorized Woods dealer has trained mechanics, genuine Woods service parts, and the necessary tools and equipment to handle all your needs.

Use only genuine Woods service parts. Substitute parts will void the warranty and may not meet standards required for safe and satisfactory operation. Record the model number and serial number of your equipment in the spaces provided:

Model: _____ **Date of Purchase:** _____

Serial Number: (see Safety Decal section for location) _____

Provide this information to your dealer to obtain correct repair parts.

Throughout this manual, the term **IMPORTANT** is used to indicate that failure to observe can cause damage to equipment. The terms **CAUTION**, **WARNING**, and **DANGER** are used in conjunction with the Safety-Alert Symbol (a triangle with an exclamation mark) to indicate the degree of hazard for items of personal safety.



This Safety-Alert Symbol indicates a hazard and means **ATTENTION! BECOME ALERT! YOUR SAFETY IS INVOLVED!**



DANGER

Indicates an imminently hazardous situation that, if not avoided, will result in death or serious injury.



WARNING

Indicates a potentially hazardous situation that, if not avoided, could result in death or serious injury, and includes hazards that are exposed when guards are removed.



CAUTION

Indicates a potentially hazardous situation that, if not avoided, may result in minor or moderate injury.

IMPORTANT

Indicates that failure to observe can cause damage to equipment.

NOTE

Indicates helpful information.

WOODS®

ALITEC™

BMP®

CENTRAL FABRICATORS®

GANNON®

GILL®

WAIN-ROY®

WOODS®

2 Introduction

Gen'1 (Rev. 6/6/2005)

TABLE OF CONTENTS

INTRODUCTION	2
GENERAL INFORMATION	3
SPECIFICATIONS	4
SAFETY RULES	5
SAFETY DECALS	8
OPERATION	10
OWNER SERVICE	14
ASSEMBLY	15
PARTS INDEX	37
BOLT TORQUE CHART	50
BOLT SIZE CHART & ABBREVIATIONS	51
PRODUCT WARRANTY	52
REPLACEMENT PARTS WARRANTY	INSIDE BACK COVER

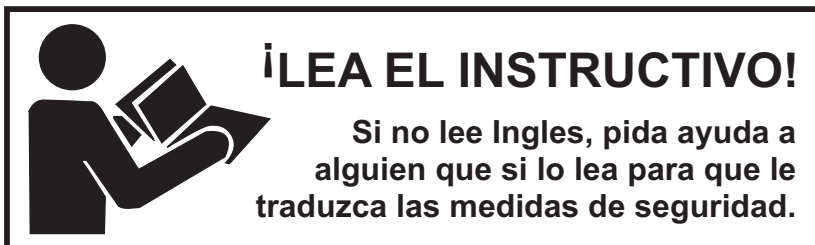

GENERAL INFORMATION

The purpose of this manual is to assist you in operating and maintaining your Rear Blade. Read it carefully. It furnishes information and instructions that will help you achieve years of dependable performance. These instructions have been compiled from extensive field experience and engineering data. Some information may be general in nature, due to unknown and varying operating conditions. However, through experience and these instructions, you should be able to develop procedures suitable to your particular situation.

The illustrations and data used in this manual were current at the time of printing. However, due to possible inline production changes, your machine may vary slightly in detail. We reserve the right to redesign and change the machines as may be necessary without notification.

Throughout this manual, references are made to right and left direction. These are determined by standing behind the tractor facing the direction of forward travel.

RB990-2 & RB1010-2 SPECIFICATIONS

<u>MODEL</u>	<u>RB990-2</u>	<u>RB1010-2</u>
Blade Width	9 ft. (2743 mm)	10 ft. (3048 mm)
Tractor hp Requirement	150 hp Maximum (112 kw)	150 hp Maximum (112 kw)
Tractor Hydraulic System Pressure	3000 psi Maximum (20.68 MPa)	3000 psi Maximum (20.68 MPa)
Weight (Hydraulic)	1519 lbs. (688 kg)	1569 lbs. (711 kg)
Weight (Manual)	1487 lbs. (673 kg)	1535 lbs. (697 kg)
Blade Position - Mechanical	Straight, forward or reverse; Angle 60 degrees, right or left in forward and reverse; Tilt 28 degrees, up or down; Offset 7 positions up to 33" (838 mm) left or right of tractor center line; Pitch adjustment in top link of tractor 3-point hitch	
Blade Positions - Hydraulic	Straight, forward or reverse; Angle 60 degrees right or left forward and reverse; Tilt 28 degrees up or down; Offset 33" (838 mm) right or left of tractor center line; Pitch adjustment in top link of tractor 3-point hitch	
Cutting Edge	1/2 x 6" (12.7 mm x 152 mm) High carbon steel, reversible	
3-Point Hitch Category	Category 2 & Category 3 Category 2 Quick attaching coupler Category 3 Quick attaching coupler	
Structural Strength		
A-Frame - - - - -	9-1/4" x 4-1/4" (235 mm x 108 mm) Formed Tubing	
Boom - - - - -	10" x 6" (254 mm x 152 mm) Tubing	
King Pin- - - - -	6-5/8" (168 mm) Tubing	
Moldboard - - - - -	Formed moldboard and all welded box section	
Pivot Assembly- - - - -	All-welded steel box section	

SAFETY RULES



ATTENTION! BECOME ALERT! YOUR SAFETY IS INVOLVED!



Safety is a primary concern in the design and manufacture of our products. Unfortunately, our efforts to provide safe equipment can be wiped out by an operator's single careless act.

In addition to the design and configuration of equipment, hazard control and accident prevention are dependent upon the awareness, concern, judgement, and proper training of personnel involved in the operation, transport, maintenance and storage of equipment.

It has been said "The best safety device is an informed, careful operator." We ask you to be that kind of operator.

TRAINING

- **Safety instructions are important! Read all attachment and power unit manuals; follow all safety rules and safety decal information. (Replacement manuals and safety decals are available from your dealer. To locate your nearest dealer, check the Dealer Locator at www.WoodsEquipment.com, or in the United States and Canada call 1-800-319-6637.) Failure to follow instructions or safety rules can result in serious injury or death.**
- **If you do not understand any part of this manual and need assistance, see your dealer.**
- **Know your controls and how to stop engine and attachment quickly in an emergency.**
- **Operators must be instructed in and be capable of the safe operation of the equipment, its attachments, and all controls. Do not allow anyone to operate this equipment without proper instructions.**
- **Keep hands and body away from pressurized lines. Use paper or cardboard, not hands or other body parts to check for leaks. Wear safety goggles. Hydraulic fluid under pressure can easily penetrate skin and will cause serious injury or death.**
- **Make sure that all operating and service personnel know that if hydraulic fluid penetrates skin, it must be surgically removed as soon as possible by a doctor familiar with this form of injury or gangrene, serious injury, or death will result. CONTACT A PHYSICIAN IMMEDIATELY IF FLUID ENTERS SKIN OR EYES. DO NOT DELAY.**
- **Never allow children or untrained persons to operate equipment.**

PREPARATION

- **Check that all hardware is properly installed. Always tighten to torque chart specifications unless instructed otherwise in this manual.**
- **Do not connect a low-pressure hydraulic hose into a high-pressure system—it will burst the hose. Do not use a high-pressure hose in place of a low-pressure hose—it is possible to rupture the valve.**
- **Always wear relatively tight and belted clothing to avoid getting caught in moving parts. Wear sturdy, rough-soled work shoes and protective equipment for eyes, hair, hands, hearing, and head; and respirator or filter mask where appropriate.**
- **Make sure attachment is properly secured, adjusted, and in good operating condition.**
- **Power unit must be equipped with ROPS or ROPS cab and seat belt. Keep seat belt securely fastened. Falling off power unit can result in death from being run over or crushed. Keep foldable ROPS system in "locked up" position at all times.**
- **Make sure all safety decals are installed. Replace if damaged. (See Safety Decals section for location.)**
- **A minimum 20% of tractor and equipment weight must be on the tractor front wheels when attachments are in transport position. Without this weight, tractor could tip over, causing personal injury or death. The weight may be attained with a loader, front wheel weights, ballast in tires or front tractor weights. Weigh the tractor and equipment. Do not estimate.**
- **Make sure circuit selector lever does not hit tractor cab, etc. throughout operating range of 3-point hitch of tractor. Bend lever, if necessary, to clear cab, but it should still be convenient to operate from the tractor seat.**

OPERATION

- **Do not allow bystanders in the area when operating, attaching, removing, assembling, or servicing equipment.**
- **Do not operate or transport equipment while under the influence of alcohol or drugs.**
- **Operate only in daylight or good artificial light.**
- **Keep hands, feet, hair, and clothing away from equipment while engine is running. Stay clear of all moving parts.**

(Safety Rules continued on next page)

SAFETY RULES



ATTENTION! BECOME ALERT! YOUR SAFETY IS INVOLVED!



(Safety Rules continued from previous page)

- Always comply with all state and local lighting and marking requirements.
- Never allow riders on power unit or attachment.
- Power unit must be equipped with ROPS or ROPS cab and seat belt. Keep seat belt securely fastened. Falling off power unit can result in death from being run over or crushed. Keep foldable ROPS system in “locked up” position at all times.
- Always sit in power unit seat when operating controls or starting engine. Securely fasten seat belt, place transmission in neutral, engage brake, and ensure all other controls are disengaged before starting power unit engine.
- Look down and to the rear and make sure area is clear before operating in reverse.
- Do not operate or transport on steep slopes.
- Do not stop, start, or change directions suddenly on slopes.
- Use extreme care and reduce ground speed on slopes and rough terrain.
- Watch for hidden hazards on the terrain during operation.
- Stop power unit and equipment immediately upon striking an obstruction. Turn off engine, remove key, inspect, and repair any damage before resuming operation.
- Before changing positions of manual swing, tilt, or angle positions:
 - Park tractor on level ground, apply parking brake, level implement boom, shut off tractor, and remove key.
 - Make manual changes slowly and carefully to prevent hazardous movement of mechanisms.
 - Never stand in positions where you could become entrapped during adjustment changes or if the 3-point hitch suddenly lowers.
- Always secure lock pins with safety pins to prevent lock pins from bumping out of the positioning holes. Failure to do so may result in accidents and/or damage to blade.
- Before transporting, pivot the unit so red reflectors face the rear.

MAINTENANCE

- Before dismantling power unit or performing any service or maintenance, follow these steps: disengage power to equipment, lower the 3-point hitch and all raised components to the ground, operate valve levers to release any hydraulic pressure, set parking brake, stop engine, remove key, and unfasten seat belt.
- Before performing any service or maintenance, lower attachment to ground, turn off engine, set parking brake, and remove key.
- Before working underneath, read manual instructions, securely block up, and check stability. Secure blocking prevents equipment from dropping due to hydraulic leak down, hydraulic system failure, or mechanical component failure.
- Always wear relatively tight and belted clothing to avoid getting caught in moving parts. Wear sturdy, rough-soled work shoes and protective equipment for eyes, hair, hands, hearing, and head; and respirator or filter mask where appropriate.
- Do not modify or alter or permit anyone else to modify or alter the equipment or any of its components in any way.
- Make sure attachment is properly secured, adjusted, and in good operating condition.
- Never perform service or maintenance with engine running.
- Keep all persons away from operator control area while performing adjustments, service, or maintenance.
- Tighten all bolts, nuts, and screws to torque chart specifications. Check that all cotter pins are installed securely to ensure equipment is in a safe condition before putting unit into service.
- Make sure all safety decals are installed. Replace if damaged. (See Safety Decals section for location.)
- Do not disconnect hydraulic lines until machine is securely blocked or placed in lowest position and system pressure is released by operating valve levers.

SAFETY RULES



ATTENTION! BECOME ALERT! YOUR SAFETY IS INVOLVED!



STORAGE

- Secure equipment parking stand(s) in park position before detaching.
- Keep children and bystanders away from storage area.

SAFETY & INSTRUCTIONAL DECALS



ATTENTION! BECOME ALERT! YOUR SAFETY IS INVOLVED!
Replace Immediately If Damaged!

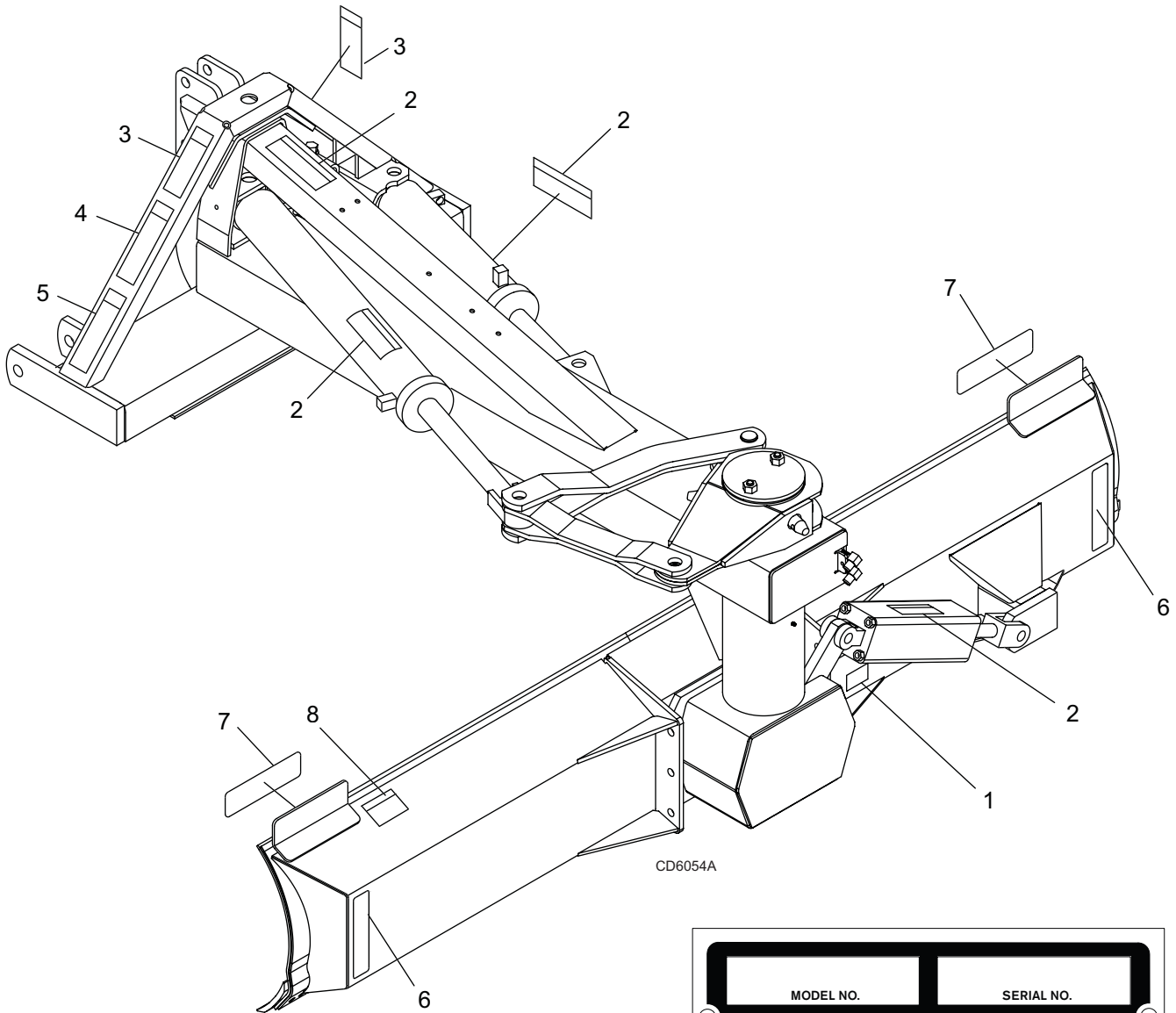

CD6054A



1 - Serial Number Plate

2 - PN 19924

<p>19924-B</p>	WARNING
	<p>HIGH-PRESSURE HYDRAULIC OIL LEAKS CAN PENETRATE SKIN RESULTING IN SERIOUS INJURY, GANGRENE OR DEATH.</p> <ul style="list-style-type: none"> ■ Check for leaks with cardboard; never use hand. ■ Before loosening fittings: lower load, release pressure, and be sure oil is cool. ■ Consult physician immediately if skin penetration occurs.



SAFETY & INSTRUCTIONAL DECALS

ATTENTION! BECOME ALERT! YOUR SAFETY IS INVOLVED!



Replace Immediately If Damaged!

3 - PN 1002941

WARNING

CRUSHING AND PINCHING HAZARD

- Be extremely careful handling various parts of the machine. They are heavy and hands, fingers, feet, and other body parts could be crushed or pinched between tractor and implement.
- Operate tractor controls from tractor seat only.
- Do not stand between tractor and implement when tractor is in gear.
- Make sure parking brake is engaged before going between tractor and implement.
- Stand clear of machine while in operation or when it is being raised or lowered.

FAILURE TO FOLLOW THESE INSTRUCTIONS COULD RESULT IN SERIOUS INJURY OR DEATH.

1002941-A

4 - PN 1004250

WARNING

TO AVOID SERIOUS INJURY OR DEATH:

- Read Operator's Manual before operating, servicing, or repairing equipment. Follow all safety rules and instructions. (Manuals are available from dealer or call 1-800-319-6637.)
- Operate from tractor seat only.
- Lower equipment to ground, stop engine, remove key, and set brake before dismounting tractor.
- Never allow children or untrained persons to operate equipment.
- Never allow riders.
- Keep bystanders away from equipment during operation.
- Keep all shields in place and in good condition.

FAILURE TO FOLLOW THESE INSTRUCTIONS CAN RESULT IN INJURY OR DEATH.

1004250

6 - PN 57123 Red Rear Reflector 2" x 9"

7 - PN 1002940 Amber Reflector 2" x 9"

BE CAREFUL!

Use a clean, damp cloth to clean safety decals.

Avoid spraying too close to decals when using a pressure washer; high-pressure water can enter through very small scratches or under edges of decals causing them to peel or come off.

Replacement safety decals can be ordered free from your Woods dealer. To locate your nearest dealer, check the Dealer Locator at www.WoodsEquipment.com, or in the United States and Canada call 1-800-319-6637.

5 - PN 1004299

WARNING

FALLING OFF CAN RESULT IN BEING RUN OVER.

- Tractor must be equipped with ROPS (or ROPS CAB) and seat belt. Keep foldable ROPS systems in "locked up" position at all times.
- Buckle Up! Keep seat belt securely fastened.
- Allow no riders.

RAISED IMPLEMENT CAN DROP AND CRUSH.

- Never go underneath raised implement which can drop from equipment or tractor 3-point hitch hydraulic leak down, hydraulic system failures, movement of control levers, or mechanical linkage failures.
- Service work does not require going underneath implement. Read manual instructions.

FALLING OFF OR GOING UNDERNEATH IMPLEMENT CAN RESULT IN SERIOUS INJURY OR DEATH.

1004299

8 - PN 1003193

WARNING

Unit must not extend more than 4 feet left of center of the tractor when driving on public roads.

1003193-A

OPERATION

! WARNING

- Never allow children or untrained persons to operate equipment.
- Do not allow bystanders in the area when operating, attaching, removing, assembling, or servicing equipment.
- Never allow riders on power unit or attachment.
- Keep all persons away from operator control area while performing adjustments, service, or maintenance.
- Keep hands and body away from pressurized lines. Use paper or cardboard, not hands or other body parts to check for leaks. Wear safety goggles. Hydraulic fluid under pressure can easily penetrate skin and will cause serious injury or death.
- Make sure that all operating and service personnel know that if hydraulic fluid penetrates skin, it must be surgically removed as soon as possible by a doctor familiar with this form of injury or gangrene, serious injury, or death will result. **CONTACT A PHYSICIAN IMMEDIATELY IF FLUID ENTERS SKIN OR EYES. DO NOT DELAY.**
- A minimum 20% of tractor and equipment weight must be on the tractor front wheels when attachments are in transport position. Without this weight, tractor could tip over, causing personal injury or death. The weight may be attained with a loader, front wheel weights, ballast in tires or front tractor weights. Weigh the tractor and equipment. Do not estimate.

! CAUTION

- Always wear relatively tight and belted clothing to avoid entanglement in moving parts. Wear sturdy, rough-soled work shoes and protective equipment for eyes, hair, hands, hearing, and head.

MOUNT BLADE TO TRACTOR

IMPORTANT

- The Rear Blade should be mounted on tractors with a maximum power rating of 150 hp (112 kw).

The Rear Blade is a 3-point Category 3 implement. It will attach to ASAE standard Category 3 quick-attach coupler or on 3-point Category 2 tractor.

1. Set the tractor drawbar in short-high position.

NOTE: Use sleeve (70) and sleeve (73) with category 3 quick hitch coupler and category 3, 3-point hitch tractor.

2. Attach tractor draft links to A-Frame with 1-1/8" pin (72), sleeves (73), washers (74). Secure with klik pins (53).
3. Connect the tractor top link to desired top link hole in A-Frame, using 1 x 4-29/32" heat-treated pin (69) and klik pin (32). Level the boom by adjusting lift and top links.
4. Position sway blocks to eliminate side sway or install sway braces if required.

NOTE: The drawbar may have to be removed on some tractors. Make sure blade is at least 6" (152 mm) from tractor tires throughout operating range of 3-point hitch.

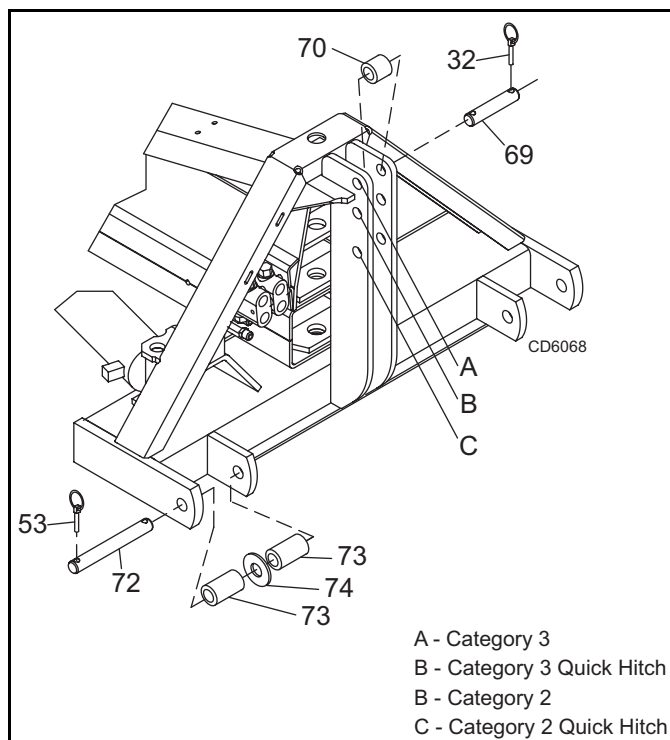

Figure 1. Three Point Hitch Connection

! CAUTION

- Before changing positions of manual swing, tilt, or angle positions:
 - Park tractor on level ground, apply parking brake, level implement boom, shut off tractor, and remove key.
 - Make manual changes slowly and carefully to prevent hazardous movement of mechanisms.
 - Never stand in positions where you could

become entrapped during adjustment changes or if the 3-point hitch suddenly lowers.

CAUTION

■ Always secure lock pins with safety pins to prevent lock pins from bumping out of the positioning holes. Failure to do so may result in accidents and/or damage to blade.

Blade Angle Adjustment

The blade may be angled from 0 to 60 degrees to the right or left by hydraulic remote control from the tractor seat.

1. Raise the blade a few inches off the ground by operating the lift control lever of the tractor.
2. Actuate the control valve to which the angling cylinder is connected.
3. On tractors with two circuit selector valves, select angling circuit and actuate the tractor control valve connected to selector valve.

NOTE: Do not operate the selector valve under load.

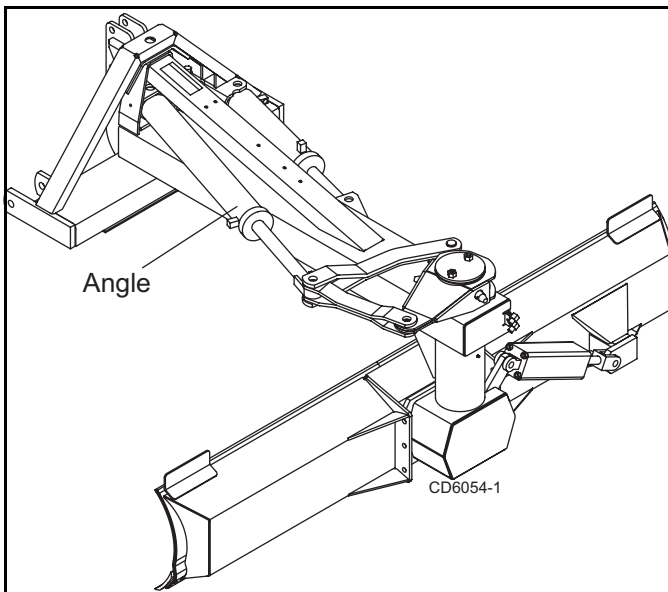

Figure 2. Angle Cylinder

Reverse Blade

The blade is reversible without removing it from the tractor.

1. Remove clinch pins (79) and index pins (45).
2. Raise blade off the ground.
3. Rotate moldboard counter-clockwise 180 degrees (viewed from the top) and replace clinch pins and index pins.

NOTE: The blade can be set to any angle from 0 to 60 degrees, right or left.

In some cases it may be necessary to offset to the right and tip up the right end of the blade to rotate it.

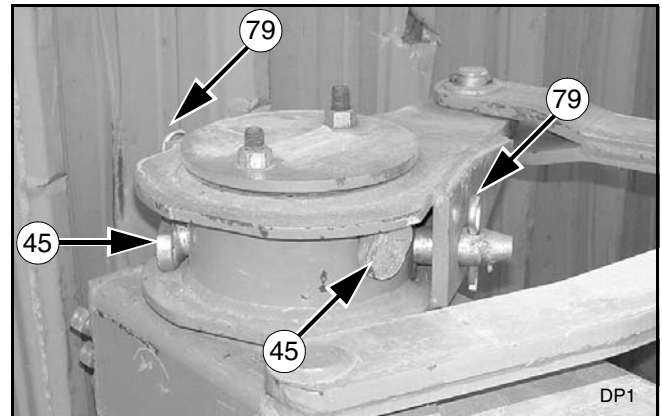

Figure 3. Index Pin Locations

Tilt Adjustment

Tilt moldboard 28 degrees up or down by using the mechanical ratchet (23) or the hydraulic tilt cylinder (22). Additional tilt adjustment can be obtained by adjusting the lift link of the 3-point hitch.

NOTE: In some cases it may not be possible to fully tilt and angle and still be able to raise the blade high enough to clear the ground. In this case, use less tilt.

It is possible for the blade to contact other components if the blade is tilted when angled. Operate blade slowly when angling blade.

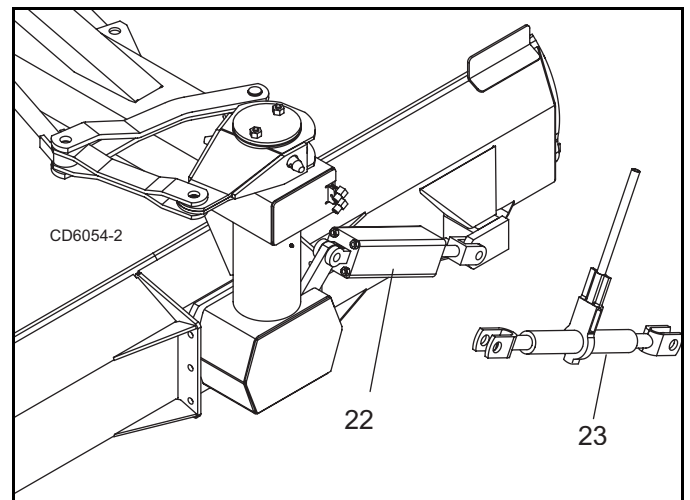

Figure 4. Tilt Cylinder and Ratchet

Offset

Mechanical Adjustment

Mechanical adjustment model has seven blade offset positions. Hole positions in offset links (11 & 12) allows

boom to rotate 30 degrees to the right or left with a maximum blade offset of 33 inches (838 mm).

To offset the blade:

1. Park the tractor on level ground.
2. Apply parking brake and raise blade 2" (51 mm) above the ground.
3. Shut off the engine and level the boom.
4. Remove rivet pin (59), swing the boom to the desired position, and replace the pins.

IMPORTANT

Rivet pin (59) is designed to shear at a predetermined load to prevent damage to the blade. Using any pin other than Woods standard rivet pin will damage the blade and void warranty.

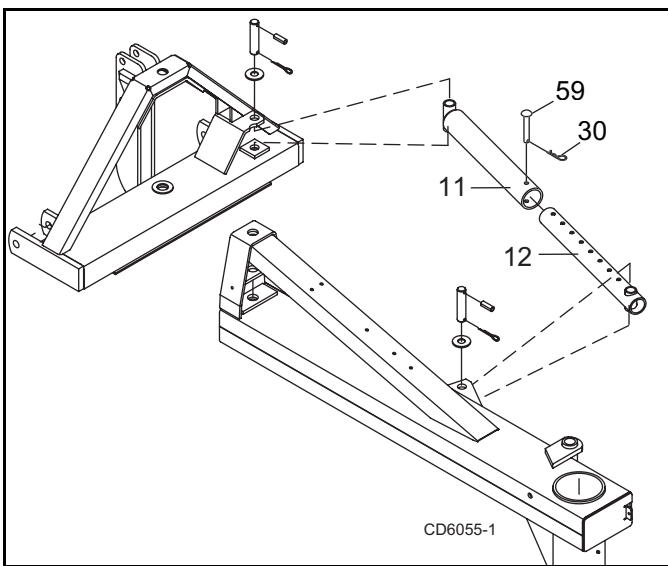

Figure 5. Mechanical Offset.

Adjustment with Hydraulic Offset Cylinder

The offset cylinder (10) rotates the boom 30 degrees right or left or to any position in between, resulting in a maximum of 33" (838 mm) offset to right or left.

To offset the blade:

1. Raise blade a few inches above the ground by operating the lift control lever of the tractor.
2. Actuate the control valve to which the offset cylinder is connected.
3. On tractors having two circuit selector valves, select offset circuit and actuate tractor control valve connected to selector valve.

NOTE: Do not operate the selector valve under load.

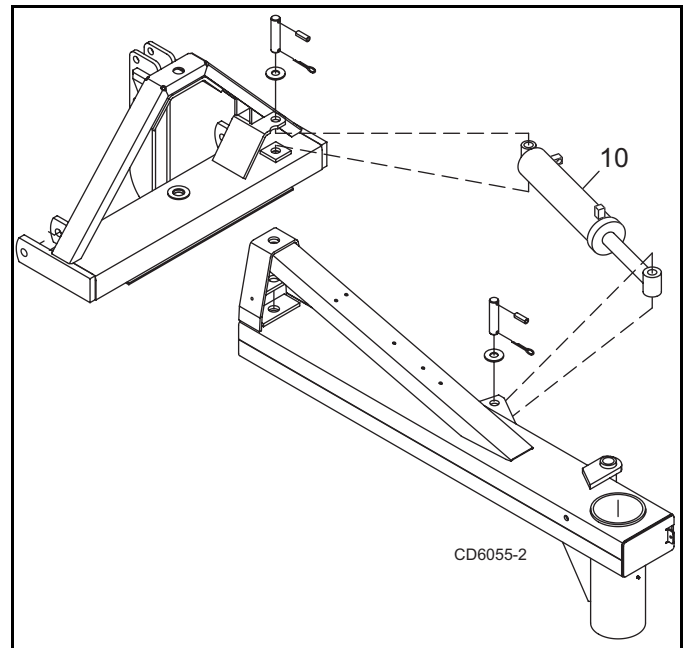

Figure 6. Hydraulic Offset

OPERATING TIPS

WARNING

- Look down and to the rear and make sure area is clear before operating in reverse.
- Do not operate on steep slopes.
- Do not stop, start, or change directions suddenly on slopes.
- Use extreme care and reduce ground speed on slopes and rough terrain.
- Watch for hidden hazards on the terrain during operation.
- Before working underneath, read manual instructions, securely block up, and check stability. Secure blocking prevents equipment from dropping due to hydraulic leak down, hydraulic system failure, or mechanical component failure.
- Stop power unit and equipment immediately upon striking an obstruction. Turn off engine, remove key, inspect, and repair any damage before resuming operation.

BACKFILLING

For backfilling ditches or trenches, reverse the blade by rotating counter-clockwise and back push.

LEVELING AND GRADING

Set the blade to the desired position of offset, angle and tilt for leveling and grading.

PRE-OPERATION CHECK LIST
(OPERATOR'S RESPONSIBILITY)

- ___ Review and follow all safety rules and safety decal instructions on pages 5 through 9.
- ___ Check that equipment is properly and securely attached to tractor.
- ___ Check that all safety decals are installed and in good condition. Replace if damaged.
- ___ Check that all hardware and cotter pins are properly installed and secured.

PRE-OPERATION CHECK LIST
(OPERATOR'S RESPONSIBILITY)

- ___ Check all lubrication points are greased.
- ___ Check that blade cutting edge is in good condition.
- ___ Check that all hydraulic hoses and fittings are in good condition and not leaking before starting tractor. Check that hoses are not twisted, bent sharply, kinked, frayed or pulled tight. Replace any damaged hoses immediately.

OWNER SERVICE

WARNING

■ Keep hands and body away from pressurized lines. Use paper or cardboard, not hands or other body parts to check for leaks. Wear safety goggles. Hydraulic fluid under pressure can easily penetrate skin and will cause serious injury or death.

■ Make sure that all operating and service personnel know that if hydraulic fluid penetrates skin, it must be surgically removed as soon as possible by a doctor familiar with this form of injury or gangrene, serious injury, or death will result. CONTACT A PHYSICIAN IMMEDIATELY IF FLUID ENTERS SKIN OR EYES. DO NOT DELAY.

■ Before working underneath, read manual instructions, securely block up, and check stability. Secure blocking prevents equipment from dropping due to hydraulic leak down, hydraulic system failure, or mechanical component failure.

■ Never perform service or maintenance with engine running.

■ Before dismounting power unit or performing any service or maintenance, follow these steps: disengage power to equipment, lower the 3-point hitch and all raised components to the ground, operate valve levers to release any hydraulic pressure, set parking brake, stop engine, remove key, and unfasten seat belt.

■ Keep all persons away from operator control area while performing adjustments, service, or maintenance.

CAUTION

■ Always wear relatively tight and belted clothing to avoid entanglement in moving parts. Wear sturdy, rough-soled work shoes and protective equipment for eyes, hair, hands, hearing, and head.

Blade Cutting Edge

To reverse the cutting edge

1. Remove the 5/8" plow bolts.
2. Remove the cutting edge from the moldboard and reinstall with the sharp edge down.
3. Replace cutting edge when both edges are worn.

Lubrication

Weekly

1. Oil the pivot pins with SAE 30 oil.
2. Grease pivot post.
3. Lubricate between moldboard and retaining brackets with grease or oil. Fully tilt blade in one direction. Apply lubricant. Tilt blade in opposite direction and apply lubricant.

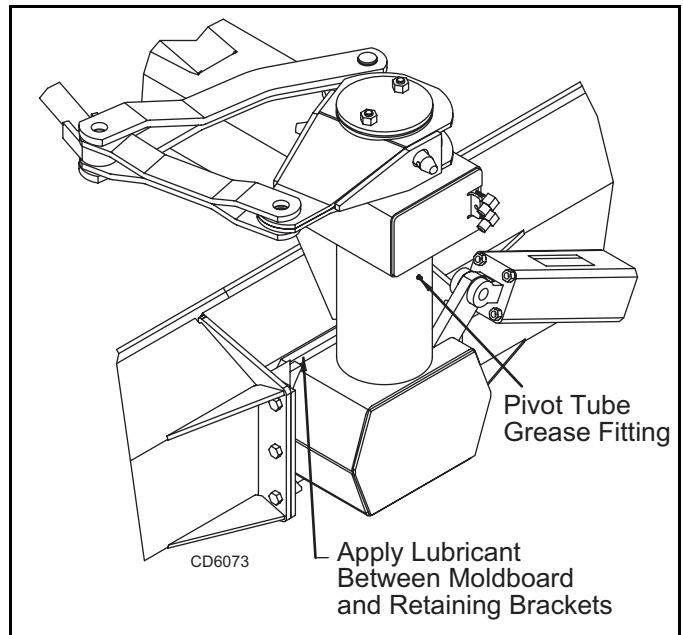

Figure 7. Lubrication Points

Bolts

1. Check bolts periodically to be sure they are tight.
2. Replace bolts as needed.

NOTE: Replacement bolts must have the same strength markings on the heads. Refer to Bolt Torque Chart on page 52.

Cleaning

After Each Use

- Remove large debris such as clumps of dirt, grass, crop residue, etc. from machine.
- Inspect machine and replace worn or damaged parts.
- Replace any safety decals that are missing or not readable.

Periodically or Before Extended Storage

- Clean large debris such as clumps of dirt, grass, crop residue, etc. from machine.
- Remove the remainder using a low-pressure water spray.
 1. Be careful when spraying near scratched or torn safety decals or near edges of decals as water spray can peel decal off surface.
 2. Be careful when spraying near chipped or scratched paint as water spray can lift paint.
 3. If a pressure washer is used, follow the advice of the pressure washer manufacturer.
- Inspect machine and replace worn or damaged parts.
- Sand down scratches and the edges of areas of missing paint and coat with Woods spray paint of matching color (purchase from your Woods dealer).
- Replace any safety decals that are missing or not readable (supplied free by your Woods dealer). See Safety Decals section for location drawing.

ASSEMBLY

WARNING

- Before working underneath, read manual instructions, securely block up, and check stability. Secure blocking prevents equipment from dropping due to hydraulic leak down, hydraulic system failure, or mechanical component failure.
- Keep all persons away from operator control area while performing adjustments, service, or maintenance.
- Keep hands and body away from pressurized lines. Use paper or cardboard, not hands or other body parts to check for leaks. Wear safety goggles. Hydraulic fluid under pressure can easily penetrate skin and will cause serious injury or death.
- Make sure that all operating and service personnel know that if hydraulic fluid penetrates skin, it must be surgically removed as soon as possible by a doctor familiar with this form of injury or gangrene, serious injury, or death will result. **CONTACT A PHYSICIAN IMMEDIATELY IF FLUID ENTERS SKIN OR EYES. DO NOT DELAY.**

CAUTION

- Always wear relatively tight and belted clothing to avoid entanglement in moving parts. Wear sturdy, rough-soled work shoes and protective equipment for eyes, hair, hands, hearing, and head.
- Tighten all bolts, nuts and screws to torque chart specifications. Check that all cotter pins are installed securely to ensure equipment is in a safe condition before putting unit into service.

Dealer Set-Up Instructions

Assembly of this equipment is the responsibility of the Woods dealer. It should be delivered to the owner completely assembled, lubricated, and adjusted for normal operating conditions.

Assembly will be easier if components are aligned and loosely assembled before tightening hardware. Recommended torque values for hardware are located on page 52.

ASSEMBLY TABLE OF CONTENTS

MAIN ASSEMBLY	18
MANUAL CONFIGURATION RB990MA-2 / RB1010MA-2	23
HYDRAULIC TILT KIT 1004908 (OPTIONAL)	29
HYDRAULIC OFFSET KIT 1004907 (OPTIONAL)	25
SELECTOR VALVE KIT 1004909 (OPTIONAL)	27
HYDRAULIC CONFIGURATION RB990H-2 / RB1010H-2	30
PNEUMATIC TAIL WHEEL (OPTIONAL)	34

Attach Parking Stand

1. Attach the parking stand brackets (2) to bottom of A-Frame. Secure using four cap screws (55) and washers (57).

2. Install parking stand (3) between brackets. Secure with cap screw (56), lock nut (58), clevis pin (54), and two safety pins (30).

NOTE: Do not over tighten cap screw (56). Parking stand needs to pivot freely.

3. Remove A-Frame from crate.

- 2. Bracket, Parking Stand
- 3. Stand, Assembly
- 30. Pin, Safety 3/16
- 54. Pin, Headless .50 x 3.78
- 55. Screw, HHCS 1/2 NC x 1-1/4 GR5
- 56. Screw, HHCS 1/2 NC x 3-1/2 GR5
- 57. Washer, Flat 1/2 SAE
- 58. Nut, Lock 1/2 NC

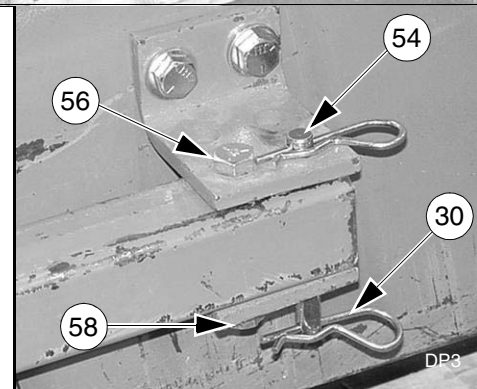
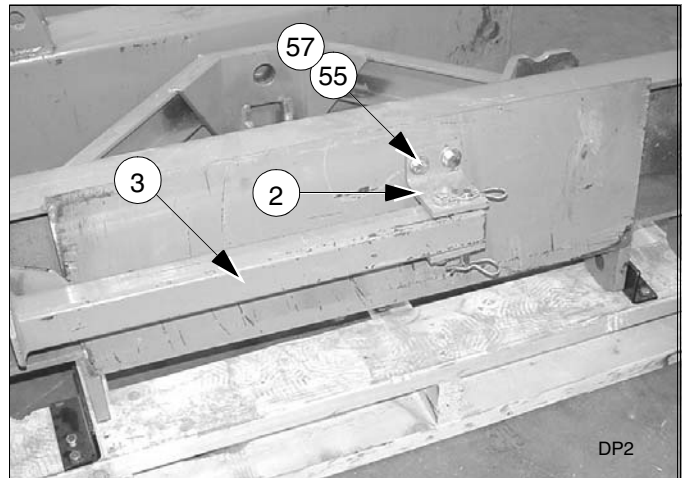

Figure 8 A-Frame and Parking Stand Assembly

Attach Pivot Assembly to Moldboard

Refer to Figure 9.

1. Position moldboard approximately 8" (203 mm) from the edge of the crate base as shown.
2. Place a 1" (25 mm) thick board under both front corners of moldboard as shown.
3. Using a lifting device, lift boom and pivot assembly and place pivot assembly over stub shaft on back of moldboard.

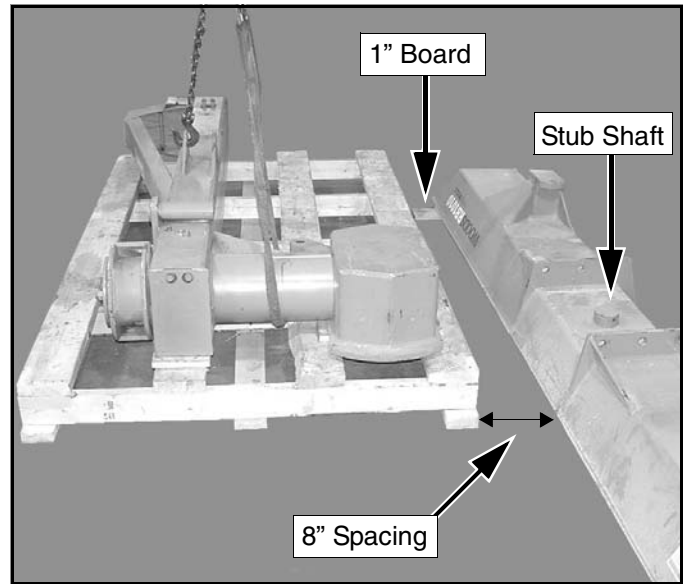

Figure 9 Pivot Assembly Positioned to Moldboard

Refer to Figure 10.

4. Attach pivot assembly to moldboard using two retaining brackets (19).
5. Secure retaining brackets using four cap screws (65) in outer holes, two cap screws (64) in center hole, and six lock nuts (66).

NOTE: Cap screws (64) must be used in the center holes.

- 19. Bracket, Retaining
- 64. Screw, HHCS 3/4 NC x 1-3/4 GR5
- 65. Screw, HHCS 3/4 NC x 2-1/4
- 66. Nut, Lock 3/4 NC

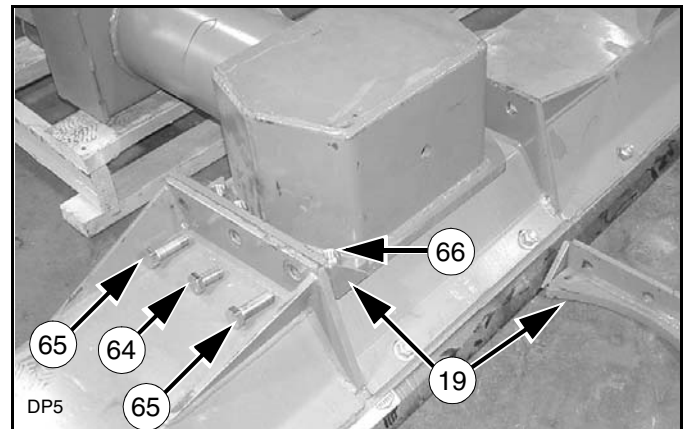

Figure 10 Pivot Assembly Installed to Moldboard

Attach A-Frame to Boom Assembly

Refer to Figure 11.

1. Attach lifting device to boom assembly, just ahead of pivot tube.
2. Carefully lift boom off crate base and rotate 90 degrees to moldboard.

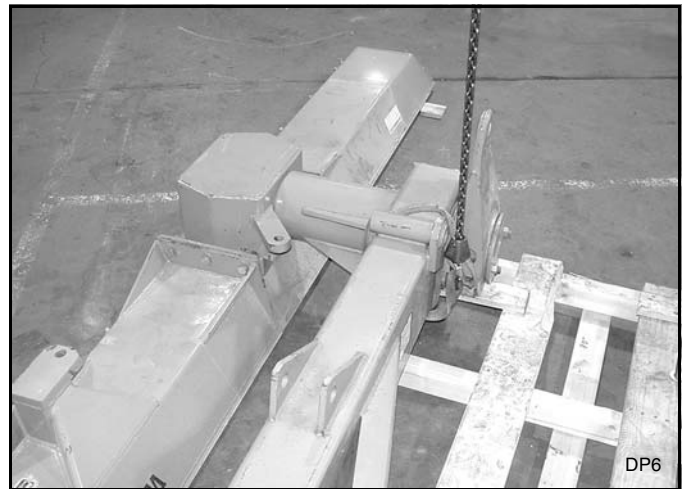

Figure 11 Lift Boom Assembly off Crate

Refer to Figure 12 and Figure 13.

3. Place a 5" (127 mm) block under pivot assembly to prevent blade assembly from rolling over backwards.
4. Place a stand 27" to 28" (685 to 711 mm) tall or heavy duty saw horse under the boom as shown.

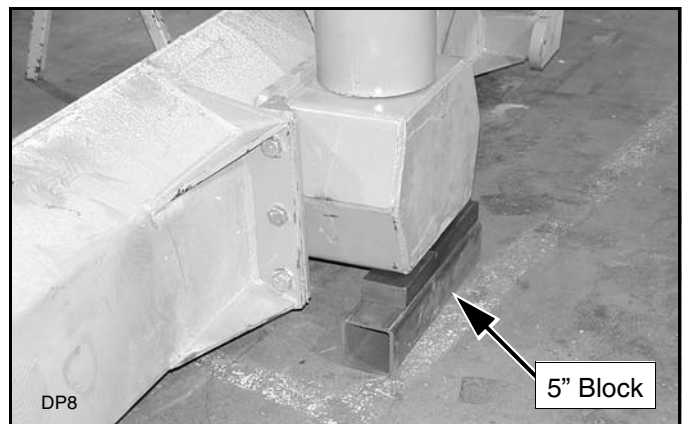

Figure 12 5" Block Under Pivot Assembly

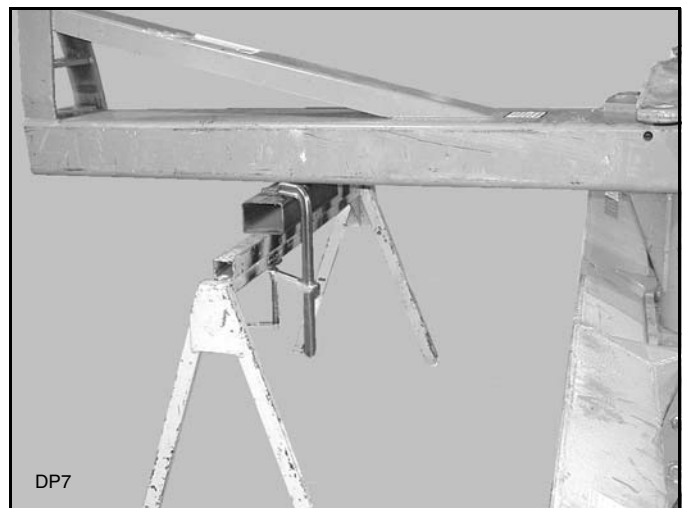

Figure 13 Stand Under Boom Assembly

Attach A-Frame to Boom Assembly (continued)

5. Place A-Frame (1) over end of boom assembly (4).
6. Insert washer(s) (83) between top of boom assembly and A-Frame. One or more washers may be needed to eliminate excessive movement between A-Frame and boom assembly.
7. Position angling hydraulic cylinder (13) in boom assembly.
8. Align holes in A-Frame, washers, boom assembly, and angling cylinder.
9. Insert pin (82) through assembly and secure with washer (83) and cotter pin (46).
10. Rotate parking stand (3) down into parking position. Secure with pin (54) and two safety pins (30) as shown in Figure 15.
11. Attach hitch pins (72), bushings (73), washers (74), and klik pins (53) to A-Frame.
12. Attach top link pin (69), bushing (70), and klik pin (32) to A-Frame.

1. A-Frame Assembly
3. Stand, Assembly
4. Boom Assembly
13. Cylinder, Hyd 4 x 30
30. Pin, Safety 3/16
32. Pin, Klik 1/4 x 1-3/4
46. Pin, Cotter 3/8 x 2-1/2
53. Pin, Klik 7/16 x 2
54. Pin, Headless .50 x 3.78
69. Pin, Clevis 1 x 4-29/32 HT
70. Sleeve, 1.00 x 1.25 x 2.00
72. Pin, Hitch 1-1/8 x 9
73. Sleeve, 1.13 x 1.44 x 2.63
74. Washer, Flat 1.13 x 1.88 x .25
82. Pin, Pivot 1-1/2 x 26-1/4
83. Washer, 1.62 x 3.00 x .18

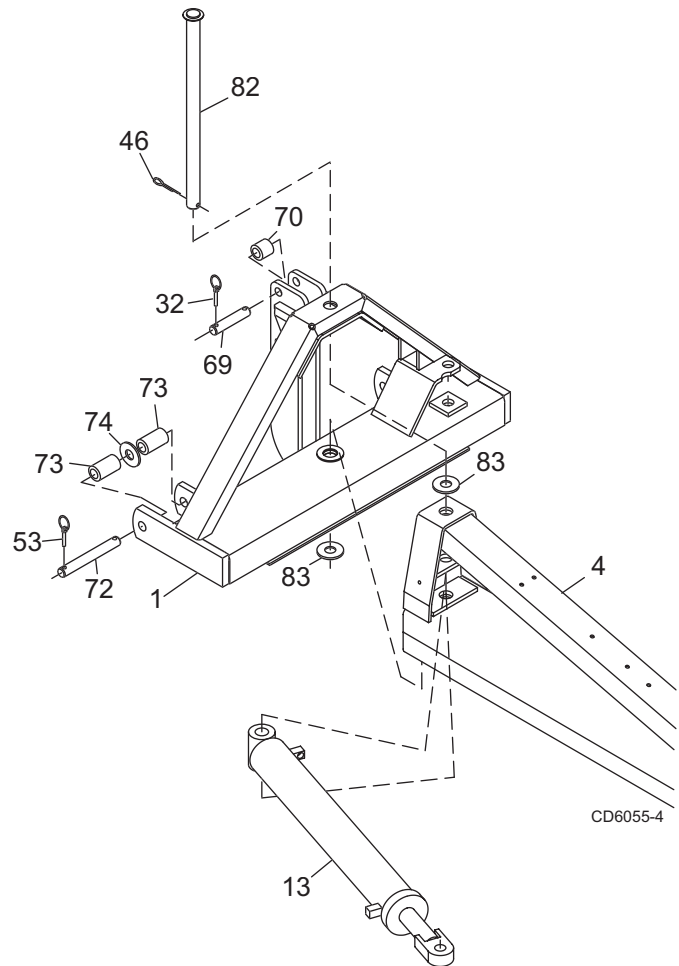

Figure 14 A-Frame to Boom Assembly Installation

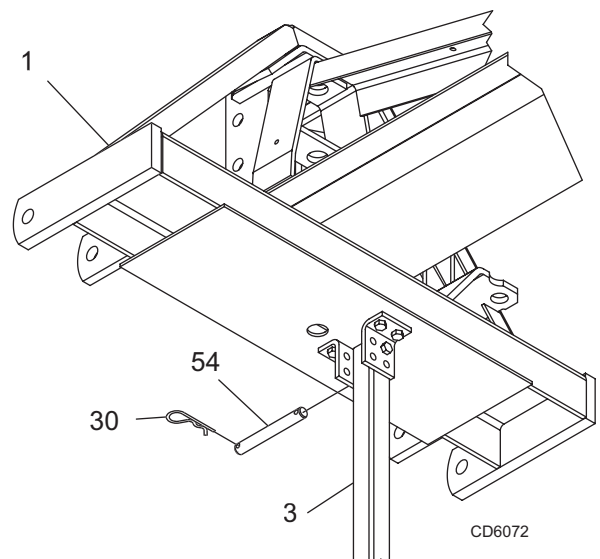

Figure 15 Parking Stand in Parking Position

Install Angling Linkage

1. Insert two index pin assemblies (79) into angling crank (16). Secure with clinch pins (45).
2. Insert Spirol pin (38) into clevis pin (76).
3. Attach one end of connecting link (15) to angling crank (16) using clevis pin (76) and flat washer (80). Secure into position with cotter pin (31).
4. Install guide link (14) (previously removed) and washer(s) (83) to boom assembly (4). Secure with cotter pin (31).

NOTE: One or more washers (83) may be needed under guide link to align rod end of cylinder (13) with connecting link (15) and guide link (14).

5. Insert Spirol pin (38) into clevis pin (77).
6. Align holes in angling cylinder (13), connecting link (15), and guide link (14).
7. Place washer (80) over top hole in guide link (14) and insert clevis pin (77) through assembly. Secure into position with cotter pin (31).

4. Boom Assembly
13. Cylinder, Hyd 4 x 30
14. Link, Guide Assembly
15. Link, Connecting
16. Crank, Angling Assembly
31. Pin, Cotter 1/4 x 2-1/4
38. Pin, Spirol 5/16 x 1-3/4
45. Pin, Clinch 3/8 x 1-1/2
76. Pin, Headless 1.25 x 3.75
77. Pin, Headless 1.25 x 6.00
79. Pin, Index Assembly
80. Washer, Flat 1.25 x 2.38 x .19
83. Washer, 1.62 x 3.00 x .18

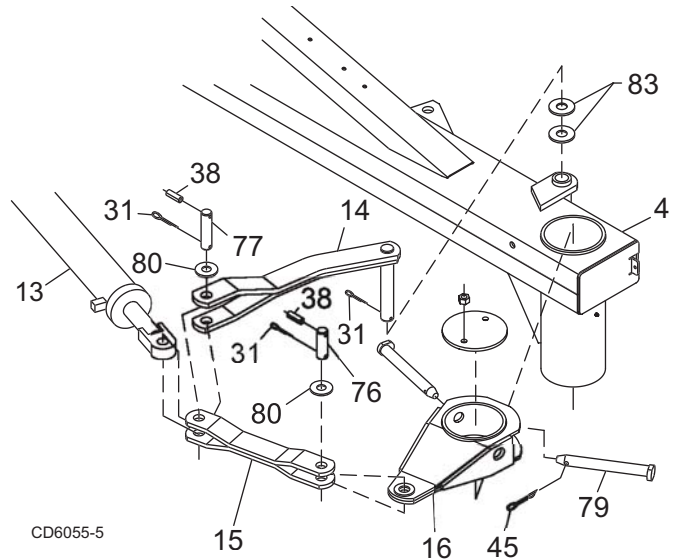

Figure 16 Angling Linkage Installation

Install Manual Tube

1. Place manual tube (7) over holes on top of boom assembly as shown in Figure 17.
2. Secure into position using three cap screws (47), six flat washers (48), (one on each side), and lock nuts (49).

- 7. Manual Storage Tube
- 47. Screw, HHCS 3/8 NC x 1-1/4 GR5
- 48. Washer, Flat 3/8 Standard
- 49. Nut, Lock 3/8 NC

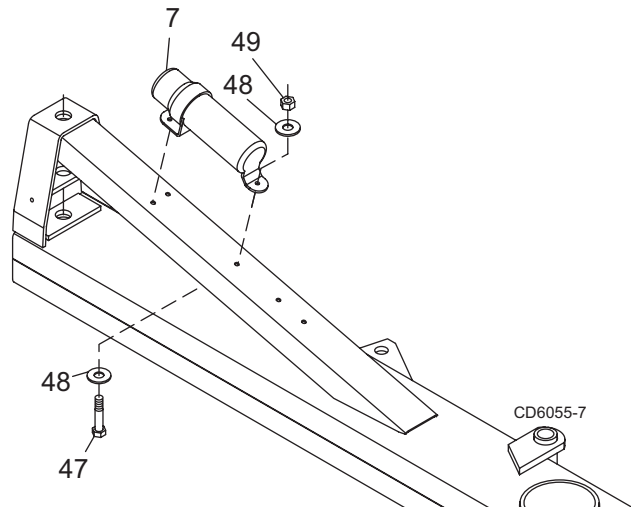

Figure 17 Manual Tube Installation

Install Slow Moving Vehicle (SMV) Sign

Refer to Figure 18.

1. Place bracket (5) on top of boom assembly and secure with two cap screws (47), four flat washers (48) (one on each side), and hex nuts (49).
2. Attach SMV socket (6) to bracket (5) using two carriage bolts (39), flat washers (40), and lock nuts (41).
3. Attach SMV sign (9) to SMV sign bracket (8) using two screws (33) and nuts (34).
4. Insert sign and bracket assembly into socket (6) to display SMV sign.

- 5. Bracket
- 6. Socket, SMV Emblem
- 8. Bracket, SMV Sign
- 9. Sign, Slow Moving Vehicle
- 33. Screw, Round Head 1/4 NC x 1/2
- 34. Nut, Hex 1/4 NC
- 39. Bolt, Carriage 5/16 NC x 1
- 40. Washer, Flat 5/16 Standard
- 41. Nut, Lock 5/16 NC
- 47. Screw, HHCS 3/8 NC x 1-1/4
- 48. Washer, Flat 3/8 Standard
- 49. Nut, Lock 3/8 NC

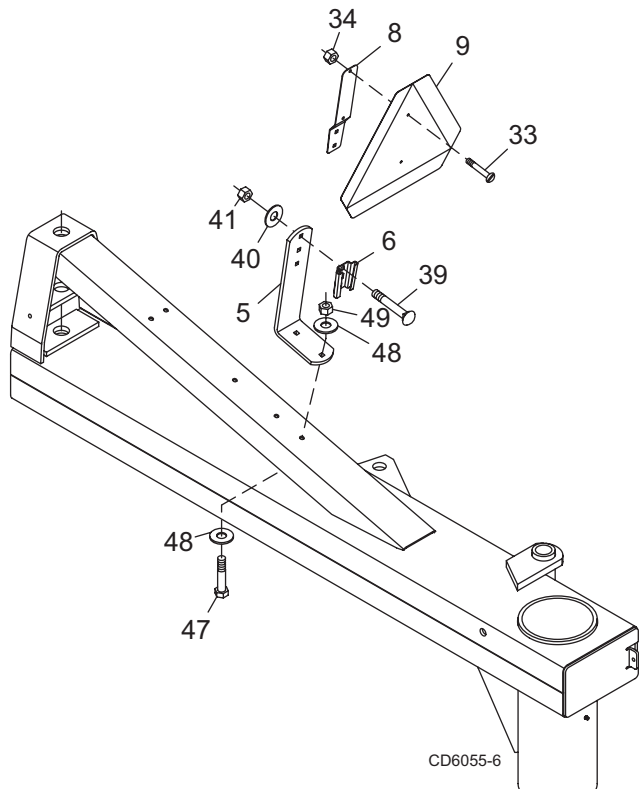

Figure 18 Slow Moving Vehicle Sign Installation

NOTE: For complete RB990H-2 / RB1010H-2 Hydraulic Configuration assembly, proceed to page 30.

Manual Configuration RB990MA-2 / RB1010MA-2

1. Attach ratchet (23) to moldboard (20) and pivot assembly (18) using pins supplied with ratchet.
2. Insert inner offset link (12) into outer offset link (11).
3. Attach outer offset link to bracket on A-Frame and insert clevis pin (78). Secure with Spirol pin (38), washer (80), and cotter pin (31).
4. Attach inner offset link to the boom assembly and insert clevis pin (77). Secure with Spirol pin (38), washer (80), and cotter pin (31).

5. Rotate A-Frame to desired position. Align holes in inner and outer offset links. Insert rivet pin (59) and secure with safety pin (30).

NOTE: Two additional rivet pins (59) are supplied. Rivet pins are used as a shear pin during operation.

IMPORTANT

■ Rivet pin (59) is designed to shear at a predetermined load to prevent damage to the blade. Using any pin other than Woods standard rivet pin will damage the blade and void warranty.

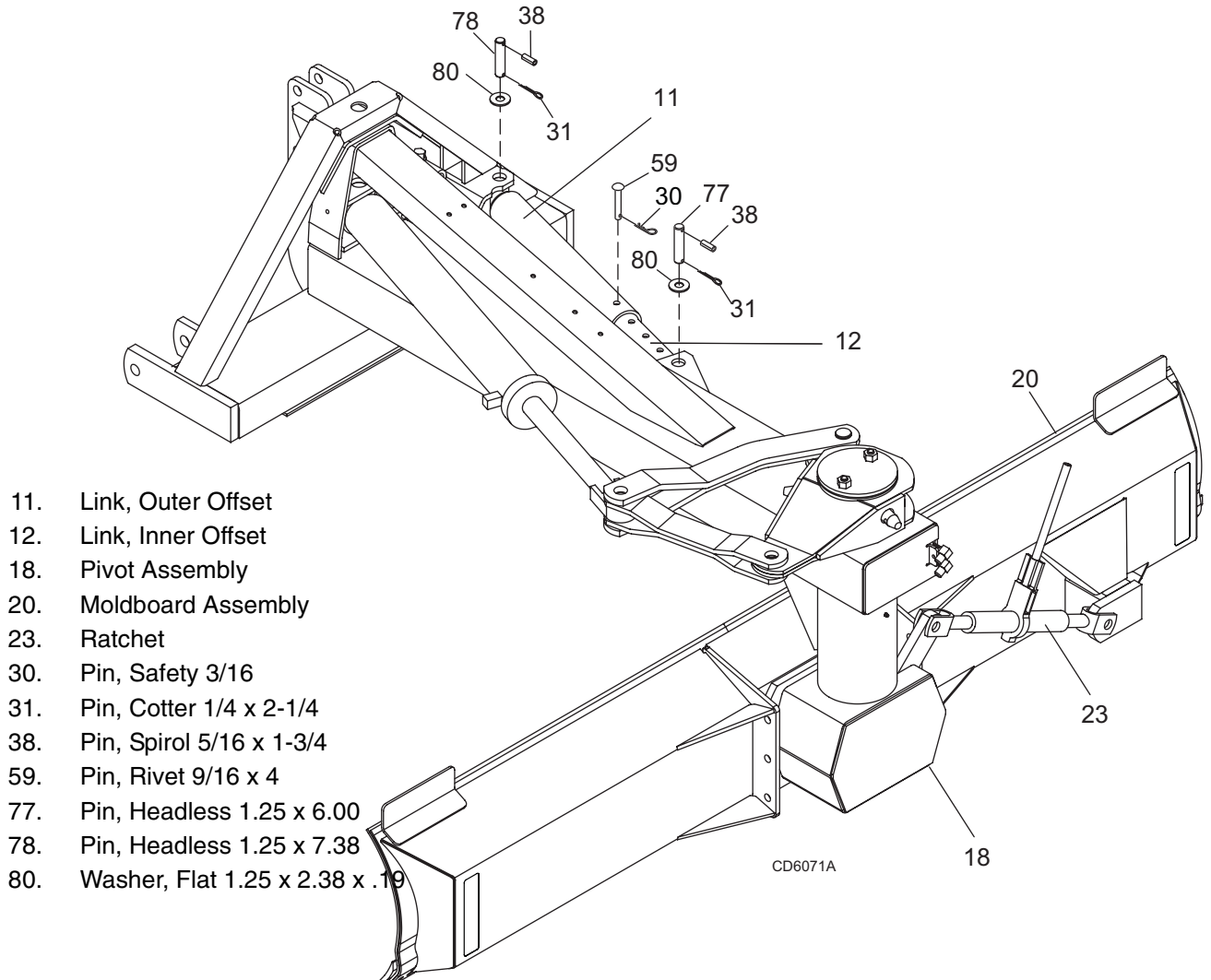

Figure 19 Manual Configuration

Install Angle Cylinder Hoses

1. Install adapter (2) into base end of angle cylinder (1).
2. Install adapter (3) into the rod end of angle cylinder (1).
3. Attach 96" hose (4) to adapter (2) and 108" hose (5) to adapter (3).
4. Wrap binding strap (7) around barrel of cylinder to secure 108" hose (5).
5. Install hose clamp (6) to A-Frame using cap screw (10) and lock nut (11). Do not tighten at this time.
6. Place hoses in clamp. Allow enough slack for hoses to move freely when cylinder moves. Tighten lock nut.

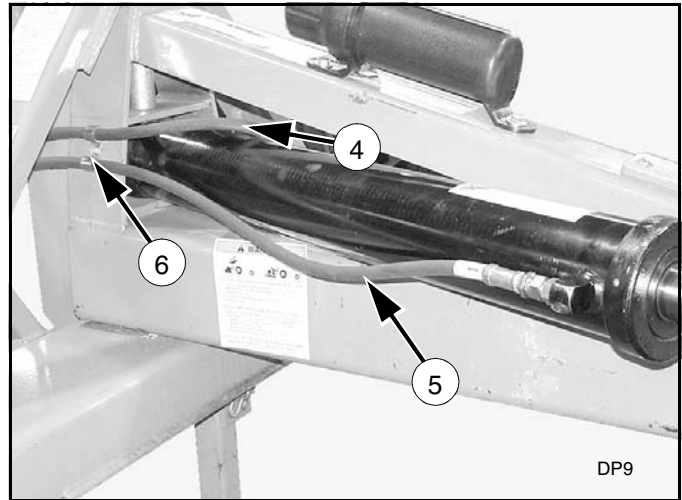
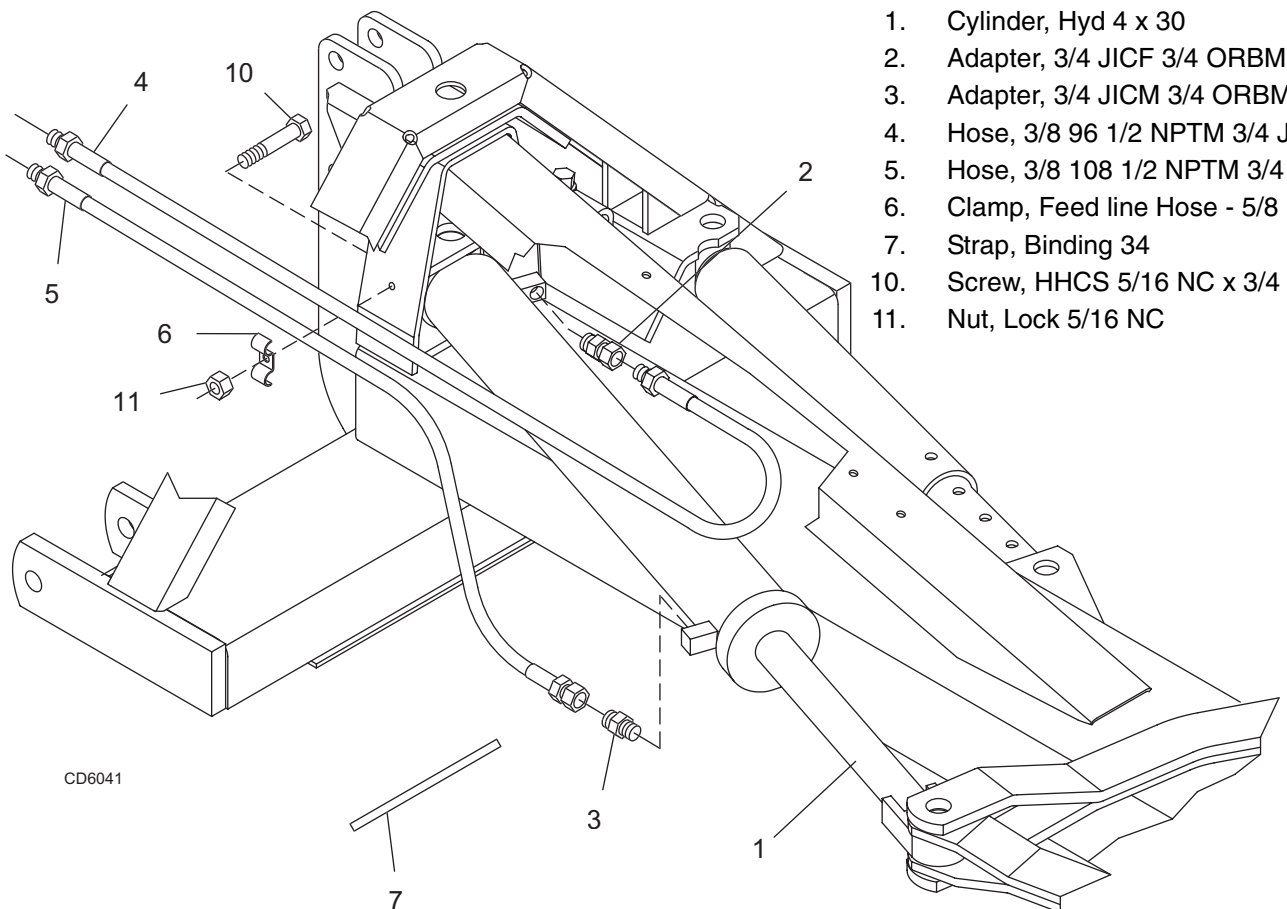

Figure 20 Angle Cylinder Hoses Installed



CD6041

Figure 21 Angle Cylinder Hose Installation

1. Cylinder, Hyd 4 x 30
2. Adapter, 3/4 JICF 3/4 ORBM
3. Adapter, 3/4 JICM 3/4 ORBM
4. Hose, 3/8 96 1/2 NPTM 3/4 JICM
5. Hose, 3/8 108 1/2 NPTM 3/4 JICF
6. Clamp, Feed line Hose - 5/8
7. Strap, Binding 34
10. Screw, HHCS 5/16 NC x 3/4 GR5
11. Nut, Lock 5/16 NC

Install Hydraulic Offset Kit 1004907 (Optional)

Refer to Figure 22 & Figure 23.

1. Remove inner and outer offset links if previously installed.
2. Attach the hydraulic offset cylinder (1) between the A-Frame and boom. Secure with pins and hardware removed with offset links.

Install Relief Valves

1. Attach two double relief valves (3) to boom assembly. Secure with two cap screws (32), four flat washers (33), and lock nuts (34).
2. Install elbow (17) in top port (A) of inner relief valve.

Install Adapters & Hoses

1. Remove fittings from both ports of angling cylinder (2).
2. Install adapter (16) in base end of angling cylinder and both ports of offset cylinder (1).
3. **40" Hose** - Attach male end of hose (20) to port (A) on rod end of angling cylinder (2).
4. Attach female end of hose to elbow (17) in inner top relief valve port (A).
5. Secure hose to barrel of angling cylinder with binding strap (5).
6. **30" Hose** - Attach male end of hose (19) to bottom port (C) of inner relief valve.
7. Attach female end of hose to adapter (16) in port (C) on rod end of offset cylinder (1).
8. **24" Hose** - Attach male end of one hose (18) to bottom outer relief valve port (D).
9. Attach female end of hose to adapter (16) in port (D) in base end of offset cylinder (1).
10. Attach male end of second hose (18) to top outer relief valve port (B).
11. Attach female end of second hose to adapter (16) in port (B) in base end of angling cylinder (2).

NOTE: If installing Selector Valve Kit, proceed to page 27.

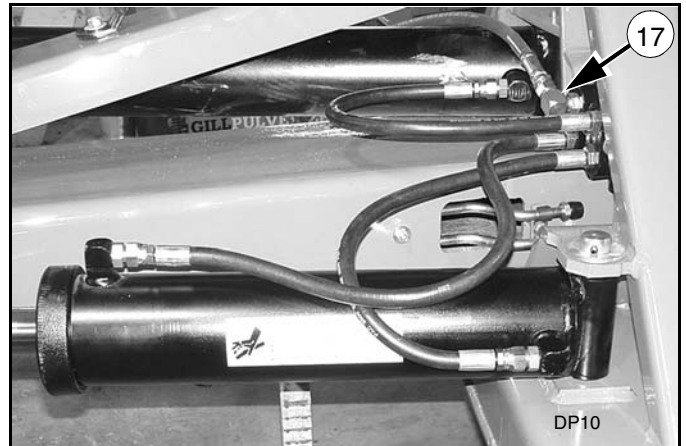

Figure 22 Offset Kit Installed

1. Cylinder, Hydraulic 4 x 16
2. Cylinder, Hydraulic, 4 x 30
3. Valve, Hyd Double Relief 1600 psi
4. Strap, Binding 14-1/2
5. Strap, Binding 34
16. Adapter, 3/4 JICM 3/4 ORBM
17. Elbow, 3/4 ORBM 3/4 JICM 90
18. Hose, 3/8 24 3/4 ORBM 3/4 JICF
19. Hose, 3/8 30 3/4 ORBM 3/4 JICF
20. Hose, 3/8 40 3/4 ORBM 3/4 JICF
21. Hose, 3/8 66 1/2 NPTM 3/4 JICF
32. Screw, HHCS 5/16 NC x 5 GR5
33. Washer, Flat 5/16 Standard
34. Nut, Lock 5/16 NC

12. Install four adapters (16) and four 66" hoses (21) to the four ports on the front of the relief valve.

13. Connect top two hoses to the tractor hydraulic couplers that control the angling cylinder (2). Secure hoses together using binding straps (4).

14. Connect the bottom two hoses to the tractor hydraulic couplers that control the offset cylinder (1). Secure hoses together using binding straps (4).

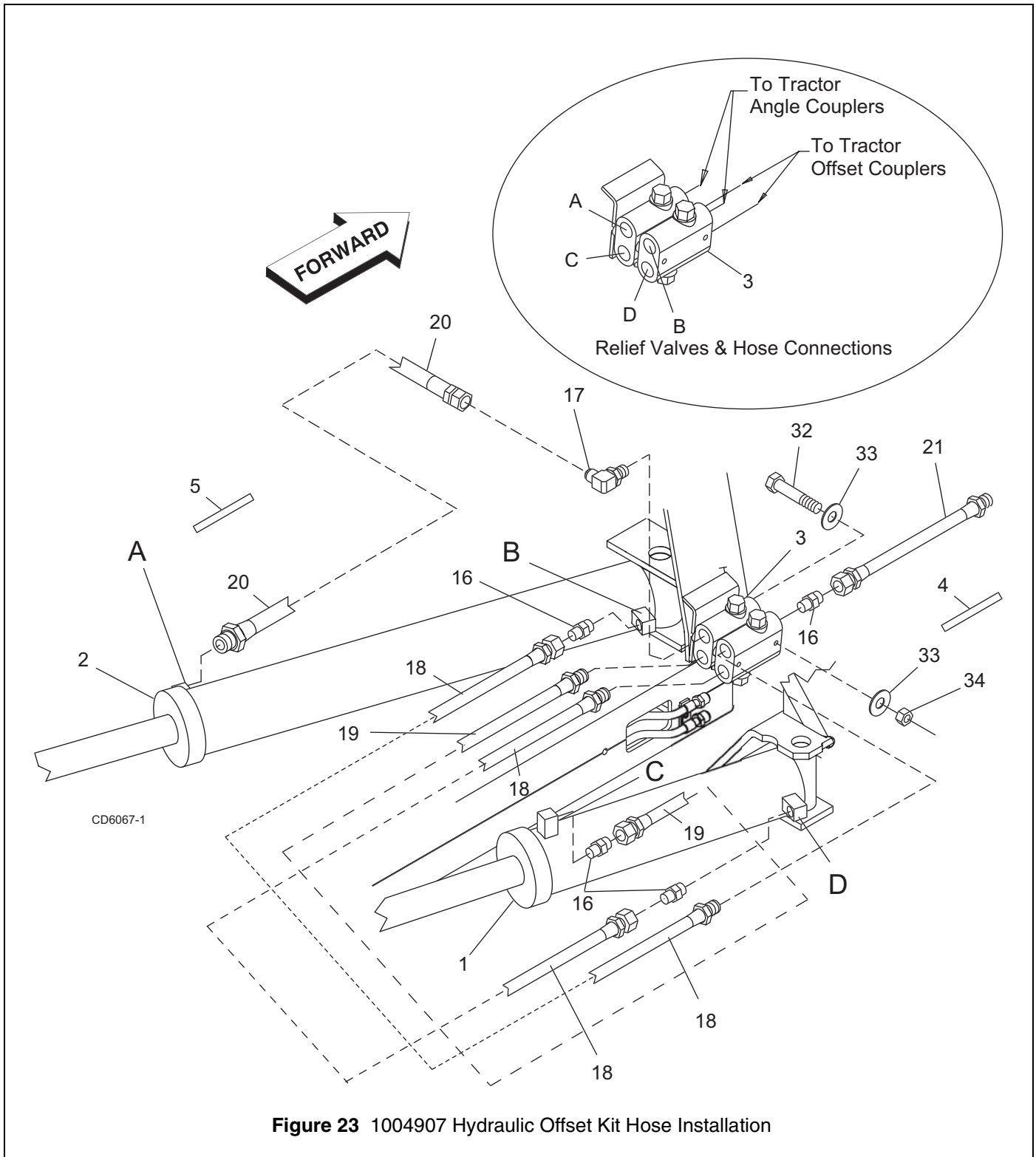

Install Selector Valve Kit 1004909 (Optional)

Refer to Figure 24, Figure 26, & Figure 27.

NOTE: Rear blade must be equipped with hydraulic angling and offset relief valves to use this kit.

1. Remove hoses and straight connectors on the front side of relief valves if previously installed.
2. Install four 45-degree elbows (5) into relief valve ports.
3. Insert two cap screws (12) through mounting plate (3).
4. Attach selector valve (1) to valve mounting plate (3). Secure with two cap screws (14), flat washers (15), and lock nuts (16).
5. Attach valve mounting bracket to A-Frame using previously installed cap screws (12) and lock nuts (13).
6. Install four adapters (4) into the side ports of the selector valve.
7. Install two elbows (6) into the front ports of the selector valve.
8. Attach 90-degree end of 28" hoses (7) to the four adapters (4) in the side ports of the selector valve.
9. Attach straight end of 28" hoses (7) to the four 45-degree elbows (5) in the front of the relief valve ports. See Figure 27 for correct hose connections.
10. Attach two 66" hoses (8) previously removed to the two elbows (6) on the front of the selector valve. Secure hoses together using binding strap (9).
11. Attach handle kit (1004296) to selector valve.

IMPORTANT

■ Make sure the selector valve does not interfere with relief valves when boom is rotated. Adjust as necessary.

■ Do not shift the selector valve with rear blade under load.

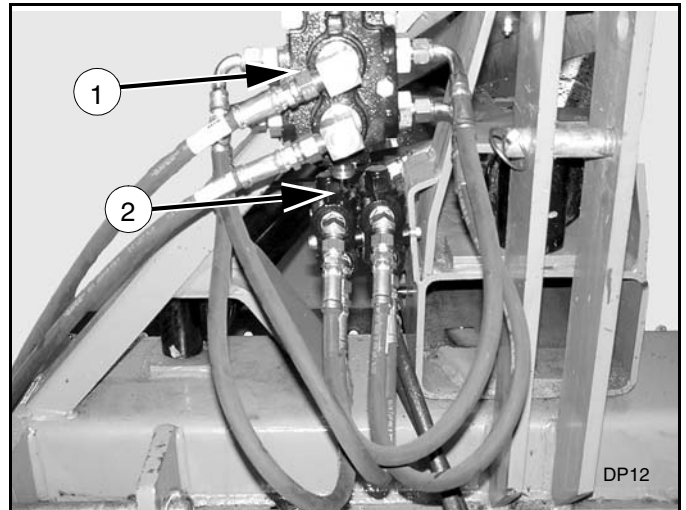

Figure 24 Selector Valve Installed

1. Valve, Hyd Double Selector
2. Valve, Hyd Double Relief 1600 psi
3. Bracket, Valve Mounting
4. Adapter, 3/4 JICM 1-1/16 ORBM
5. Elbow, Hyd 3/4 JICM 3/4 ORBM 45
6. Elbow, 3/4 JICM 1-1/16 ORBM 90
7. Hose, 3/8 28 3/4 JICF 3/4 JICF
8. Hose, 3/8 66 1/2 NPTM 3/4 JICF
9. Strap, Binding 14-1/2
12. Screw, HHCS 5/16 NC x 1 GR5
13. Nut, Flanged Lock 5/16 NC
14. Screw, HHCS 3/8 NC x 3 GR5
15. Washer, 3/8 Flat Standard
16. Nut, Lock 3/8 NC

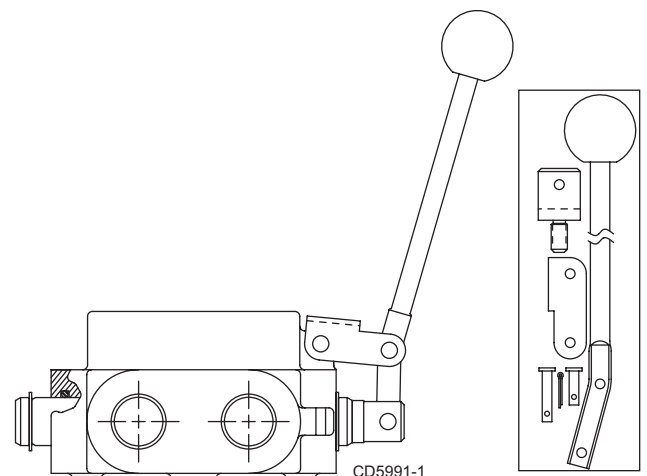

Figure 25 1004296 Handle Kit

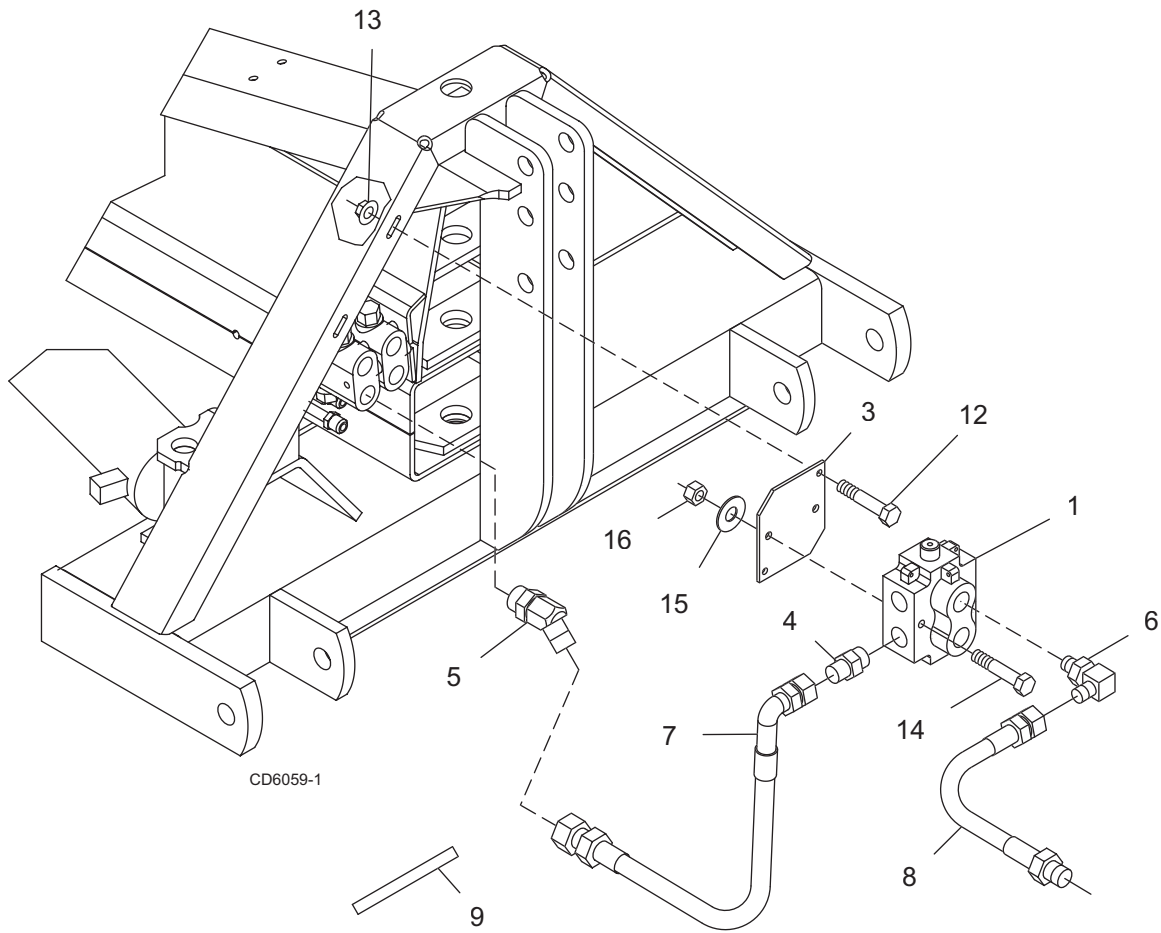

Figure 26 Selector Valve Installation

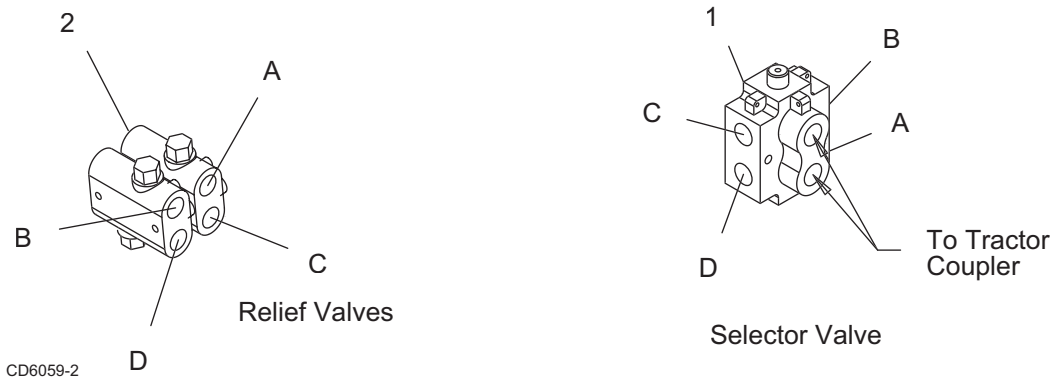

Figure 27 Selector Valve Hose Connection

Install Hydraulic Tilt Kit 1004908 (Optional)

1. Remove ratchet if previously installed.
2. Attach hydraulic cylinder (1) to pivot assembly and moldboard as shown. Secure with pins supplied with the cylinder.
3. Install two elbows (4) into ports of tilt cylinder as shown.
4. Remove caps (3) from end of hydraulic tube assemblies (2) at the end of boom.
5. Attach 45" hoses (5) to hydraulic tube assembly and elbows (4) in hydraulic cylinder.
6. Secure hoses together with binding strap (7).
7. Remove caps (3) from tube assemblies at the front of boom.
8. Attach 66" hoses (6) to tube assemblies.

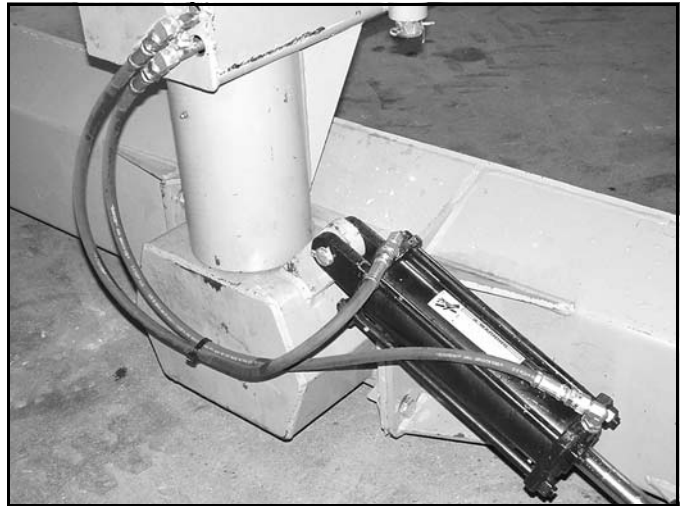
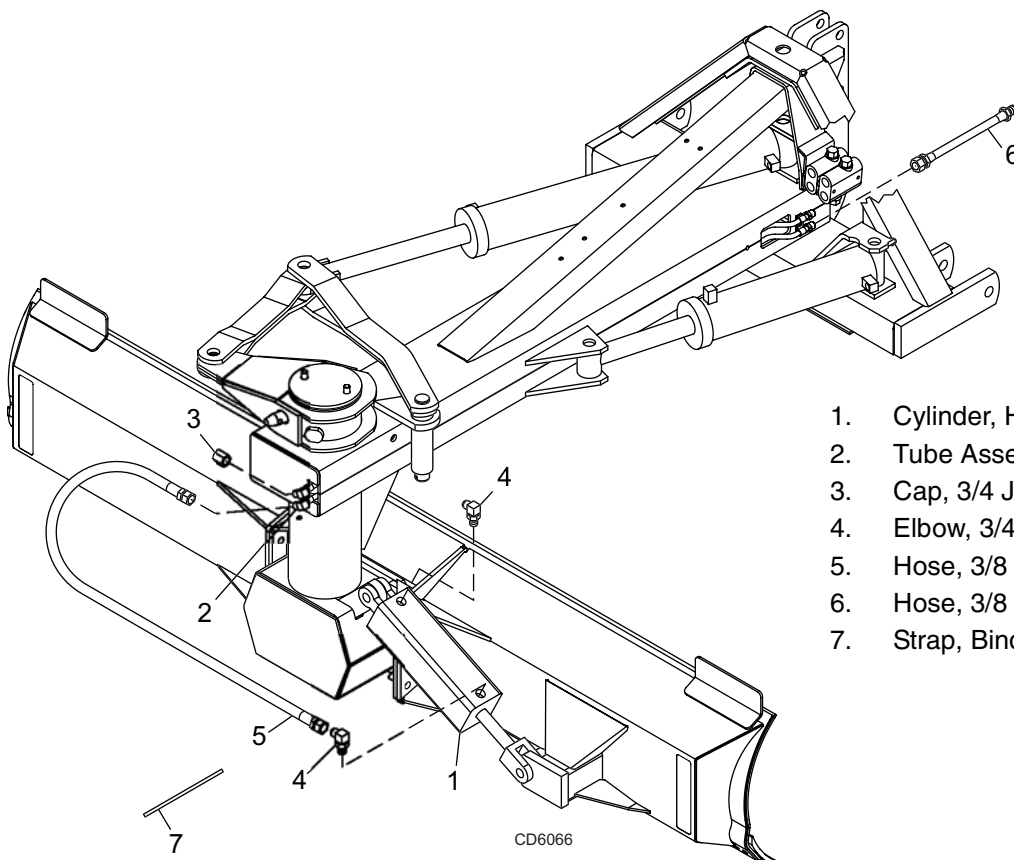

Figure 28 Optional Hydraulic Tilt Kit Installed



1. Cylinder, Hyd 3-1/2 x 10
2. Tube Assembly - Rear Blade
3. Cap, 3/4 JICF (for shipping only)
4. Elbow, 3/4 JICM 3/4 ORBM 90
5. Hose, 3/8 45 3/4 JICF 3/4 JICF
6. Hose, 3/8 66 1/2 NPTM 3/4 JICF
7. Strap, Binding 14-1/2

Figure 29 Optional Hydraulic Tilt Kit Installation

Hydraulic Configuration RB990H-2 / RB1010H-2

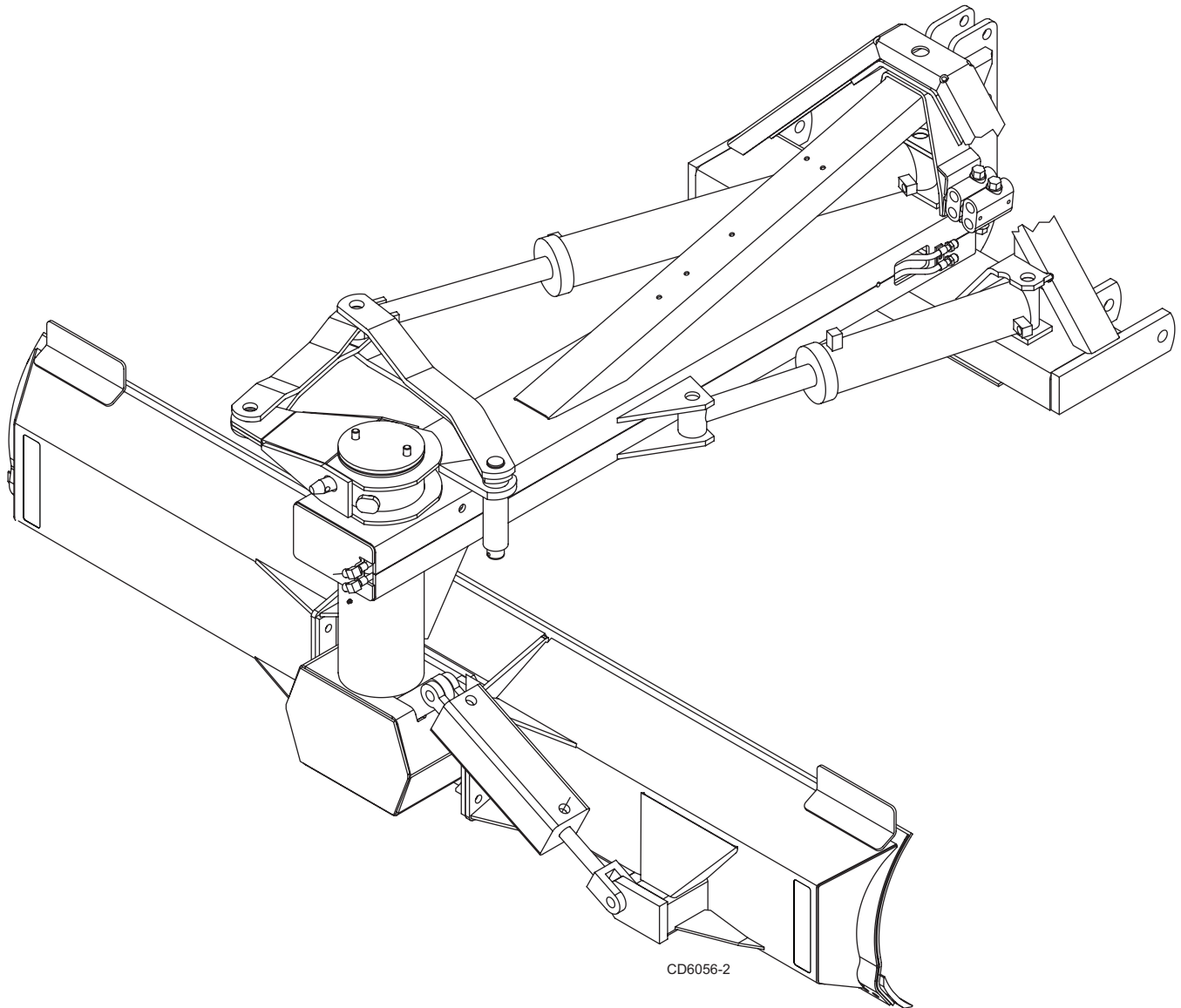

CD6056-2

Install Hydraulic Offset Cylinder & Relief Valves

Refer to Figure 30 & Figure 31.

1. Attach the hydraulic offset cylinder (1) between the A-Frame and boom. Secure with pins (77 & 78), two Spirol pins (38), washers (80), and cotter pins (31). See Figure 31 for locations.

Install Relief Valves

1. Attach two double relief valves (3) to boom assembly. Secure with two cap screws (32) four flat washers (33), and lock nuts (34).

2. Install elbow (17) in top port (A) of inner relief valve.

Install Adapters & Hoses

1. Install adapter (16) in base end port (B) of angling cylinder (2) and both ports (C & D) of offset cylinder (1).

2. **40" Hoses** - Attach male end of hose (20) to port (A) on rod end of angling cylinder (2).

3. Attach female end of hose to elbow (17) in inner top relief valve port (A).

4. Secure hose to barrel of angling cylinder with binding strap (5).

5. **30" Hose** - Attach male end of hose (19) to bottom port (C) of inner relief valve.

6. Attach female end of hose to adapter (16) in port (C) on rod end of offset cylinder (1).

7. **24" Hose** - Attach male end of one hose (18) to bottom outer relief valve ports (D).

8. Attach female end of hose to adapter (16) in port (D) in base end of offset cylinder (1).

9. Attach male end of second hose (18) to top outer relief valve ports (B).

10. Attach female end of second hose (18) to adapter (16) in port (B) in base end of angling cylinder (2).

11. **66" Hoses** - Install four adapter (16) and four hoses (22) to the four ports on the front of the relief valve.

12. Connect top two hoses to the tractor hydraulic couplers that control the angling cylinder (2). Secure hoses together using binding straps (9).

13. Connect the bottom two hoses to the tractor hydraulic couplers that control the offset cylinder (1). Secure hoses together using binding straps (9).

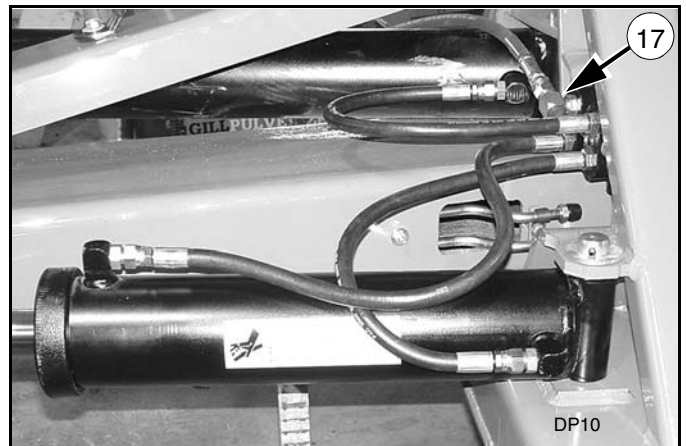
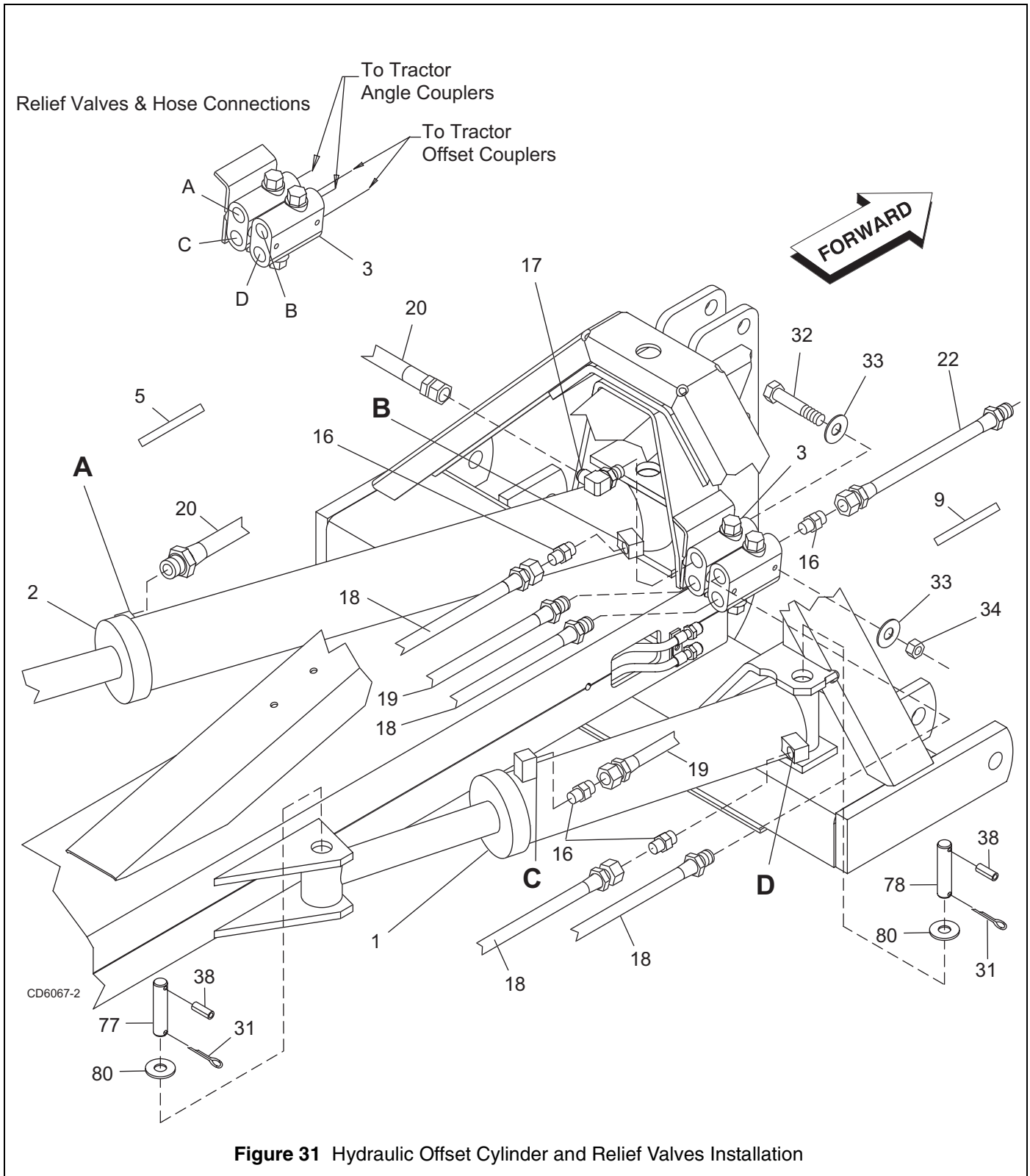

Figure 30 Offset Kit Installed

1. Cylinder, Hydraulic 4 x 16
2. Cylinder, Hydraulic, 4 x 30
3. Valve, Hyd Double Relief 1600 psi
5. Strap, Binding 34
9. Strap, Binding 14-1/2
16. Adapter, 3/4 JICM 3/4 ORBM
17. Elbow, 3/4 ORBM 3/4 JICM 90
18. Hose, 3/8 24 3/4 ORBM 3/4 JICF
19. Hose, 3/8 30 3/4 ORBM 3/4 JICF
20. Hose, 3/8 40 3/4 ORBM 3/4 JICF
22. Hose, 3/8 66 1/2 NPTM 3/4 JICF
- *31. Pin, Cotter 1/4 x 2-1/4
32. Screw, HHCS 5/16 NC x 5 GR5
33. Washer, Flat 5/16 Standard
34. Nut, Lock 5/16 NC
- *38. Pin, Spirol 5/16 x 1-3/4
- *77. Pin, Headless 1.25 x 6.00
- *78. Pin, Headless 1.25 x 7.38
- *80. Washer, 1.25 x 2.38 x .19

* Parts are from Main Assembly



Install Tilt Cylinder

1. Attach hydraulic cylinder (3) to pivot assembly and moldboard as shown. Secure with pins supplied with the cylinder.
2. Install two elbows (17) into ports of tilt cylinder as shown.
3. Remove caps (15) from end of hydraulic tube assemblies (5) at the end of boom.
4. Attach 45" hoses (21) to hydraulic tube assembly and elbows (17) in hydraulic cylinder.
5. Secure hoses together with binding strap (9).
6. Remove caps (15) from tube assemblies at the front of boom.
7. Attach two 66" hoses (22) to tube assemblies at the front of the boom.

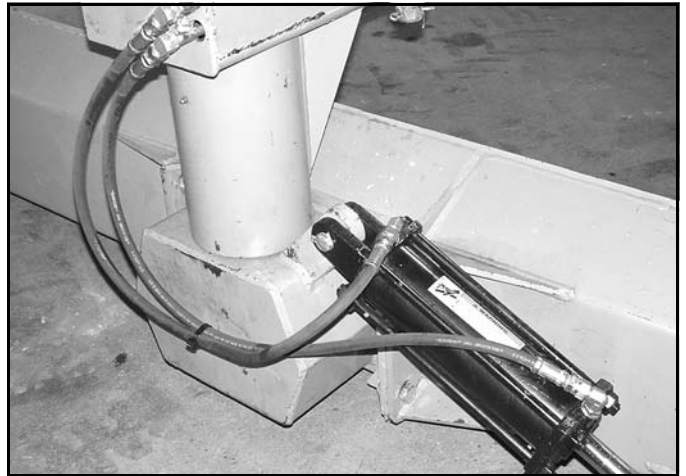
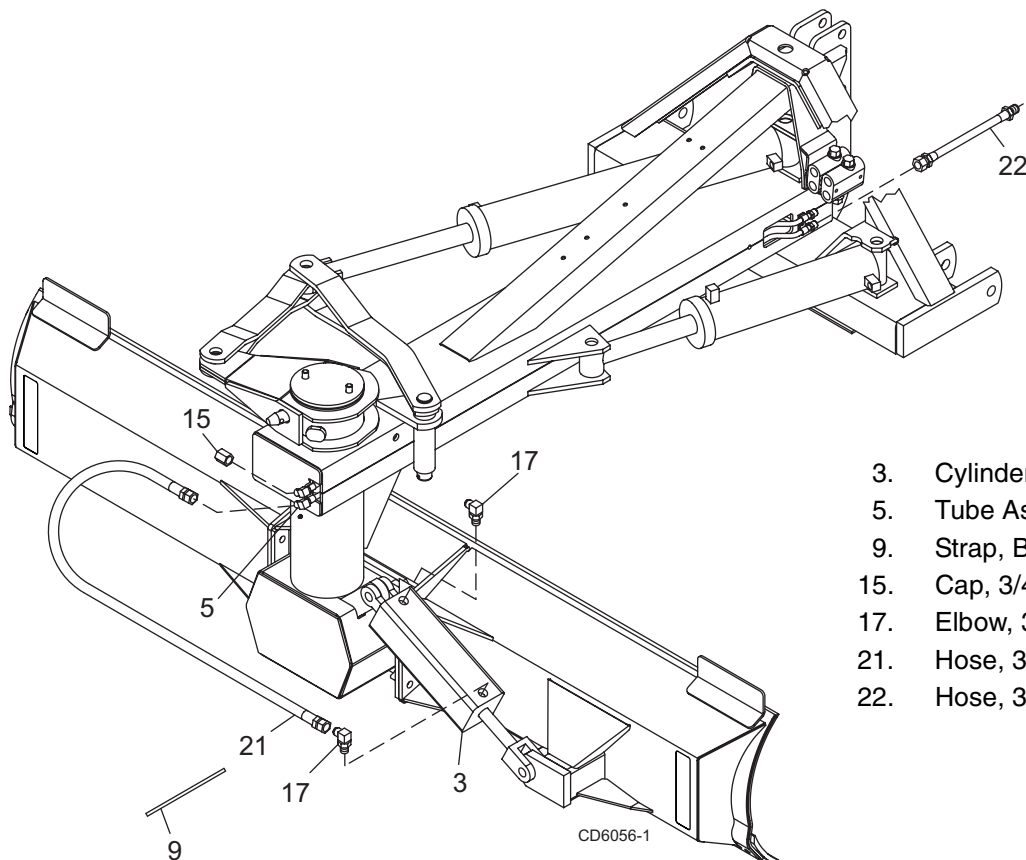

Figure 32 Tilt Cylinder Installed



3. Cylinder, Hyd 3-1/2 x 10
5. Tube Assembly - Rear Blade
9. Strap, Binding 14-1/2
15. Cap, 3/4 JICF (for shipping only)
17. Elbow, 3/4 ORBM 3/4 JICM 90
21. Hose, 3/8 45 3/4 JICF 3/4 JICF
22. Hose, 3/8 66 1/2 NPTM 3/4 JIC

Figure 33 Tilt Cylinder Installation

Install Pneumatic Tail Wheel Kit 29399 (Optional)

IMPORTANT

■ When grading with tail wheel attached, do not attach upper link of tractor 3-point hitch to blade without using floating links (17 & 18). Without floating links, equipment damage may result and void warranty.

■ Do not use this pneumatic tail wheel kit with 3-point quick hitch.

Refer to Figure 34.

The tail wheel is very helpful for finish grading and leveling work. Set approximate grading height with ratchet (12). Make fine adjustments in blade height by raising and lowering 3-point hitch.

1. Attach float links (17 & 18) and sleeve (19) to inside of the top holes of A-Frame.

NOTE: 3/4 dia. welded pin on side of float links must face outward and be located on the bottom end.

2. Secure into position with top link pin.

3. Attach bracket assembly (13) to boom assembly with clevis pin (14), two flat washers (22) and two cotter pins (21). Secure with cap screw (24).

4. Attach tail wheel arm (11) and yoke (3) to bracket (13) with clevis pin (15), washers (23), and cotter pin (21).

5. Attach ratchet (12) between bracket (13) and tail wheel arm (11). Secure with pins supplied with ratchet.

6. Attach top link to float links (17 & 18) using clevis pin (27), two SAE flat washers (25), and cotter pins (26).

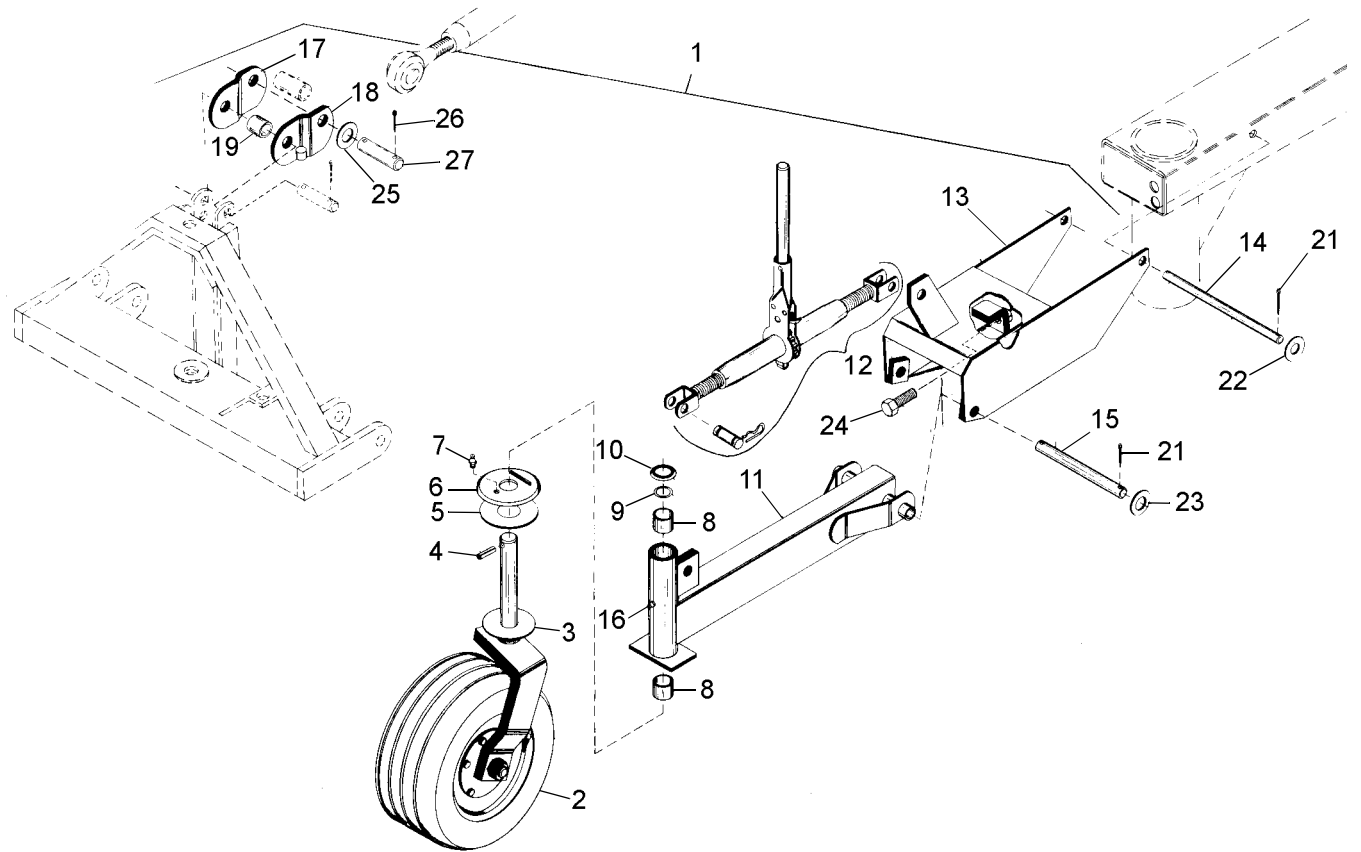

Figure 34 Pneumatic Tail Wheel Installation

- | | | | |
|-----|-----------------------------------|-----|---------------------------------------|
| 1. | Tail wheel, Pneumatic complete | 14. | Pin, Clevis 3/4 x 12-1/4 |
| 2. | Tire, Wheel & Hub | 15. | Pin, Clevis 1 x 12-1/4 |
| 3. | Wheel Yoke Assembly | 16. | Grease Fitting, 1/4-28 Tapered Thread |
| 4. | Pin, Spirol 7/16 x 2-1/2 | 17. | Link, Floating Left |
| 5. | Disc, Friction 4 x 6.15 | 18. | Link, Floating Right |
| 6. | Plate, Top Dampener | 19. | Sleeve, 1.00 x 1.25 x 1.44 |
| 7. | Grease Fitting, 1/8 Pipe Thread | 21. | Pin, Cotter 1/4 x 1-1/2 |
| 8. | Bushing, Bronze 1.5 x 1.63 x 1.50 | 22. | Washer, Flat 3/4 Standard |
| 9. | O-Ring .09 x 1.56 OD | 23. | Washer, Flat 1" Standard |
| 10. | Cap, Dust | 24. | Screw, HHCS 1/2 NC x 1-3/4 GR5 |
| 11. | Tail Wheel Arm Assembly | 25. | Washer, Flat 1" SAE |
| 12. | Ratchet | 26. | Pin, Cotter 1/4 x 2-1/4 |
| 13. | Tail Wheel Bracket Assembly | 27. | Pin, Clevis 1 x 4-29/32 HT |

PRE-DELIVERY CHECK LIST
(DEALER'S RESPONSIBILITY)

Inspect the equipment thoroughly after assembly to ensure it is set up properly before delivering it to the customer.

The following check lists are a reminder of points to inspect. Check off each item as it is found satisfactory or after proper adjustment is made.

- ___ Check that all safety decals are installed and in good condition. Replace if damaged.
- ___ Check all bolts to be sure they are properly torqued.
- ___ Check that all cotter pins and safety pins are properly installed. Replace if damaged.
- ___ Check and grease all lubrication points.

DELIVERY CHECK LIST
(DEALER'S RESPONSIBILITY)

- ___ Show customer how to make adjustments.
- ___ Point out the safety decals. Explain their meaning and the need to keep them in place and in good condition. Emphasize the increased safety hazards when instructions are not followed.
- ___ Instruct customer how to lubricate and explain importance of lubrication.
- ___ Present Operator's Manual and request that customer and all operators read it before operating equipment. Point out the manual safety rules, explain their meanings and emphasize the increased safety hazards that exist when safety rules are not followed.
- ___ Explain to customer that when equipment is transported on a road or highway, a Slow Moving Vehicle (SMV) sign should be used to provide adequate warning to operators of other vehicles.

REAR BLADES

RB990MA-2

RB990H-2

RB1010MA-2

RB1010H-2

RB990-2 / RB1010-2 MAIN ASSEMBLY	38
RB990-2 / RB1010-2 MAIN ASSEMBLY PARTS LIST	39
RB990MA-2 / RB1010MA-2 ANGLE CYLINDER (MAIN ASSEMBLY)	40
HYDRAULIC TILT KIT 1004908	41
RB990H-2 /RB1010H-2 HYDRAULIC CONFIGURATION	42
RB990H-2 /RB1010H-2 HYDRAULIC CONFIGURATION PARTS LIST ...	43
SELECTOR VALVE 1004261	43
RELIEF VALVE 1004260	43
HYDRAULIC OFFSET KIT 1004907	44
SELECTOR VALVE KIT 1004909 (OPTIONAL)	45
3.5" HYDRAULIC CYLINDER ASSEMBLY & PARTS LIST	46
4.0" HYDRAULIC CYLINDER ASSEMBLY & PARTS LIST	47
PNEUMATIC TAIL WHEEL ASSEMBLY	48
WHEEL HUB, TIRE & WHEEL ASSEMBLY	49

RB990-2 / RB1010-2 MAIN ASSEMBLY

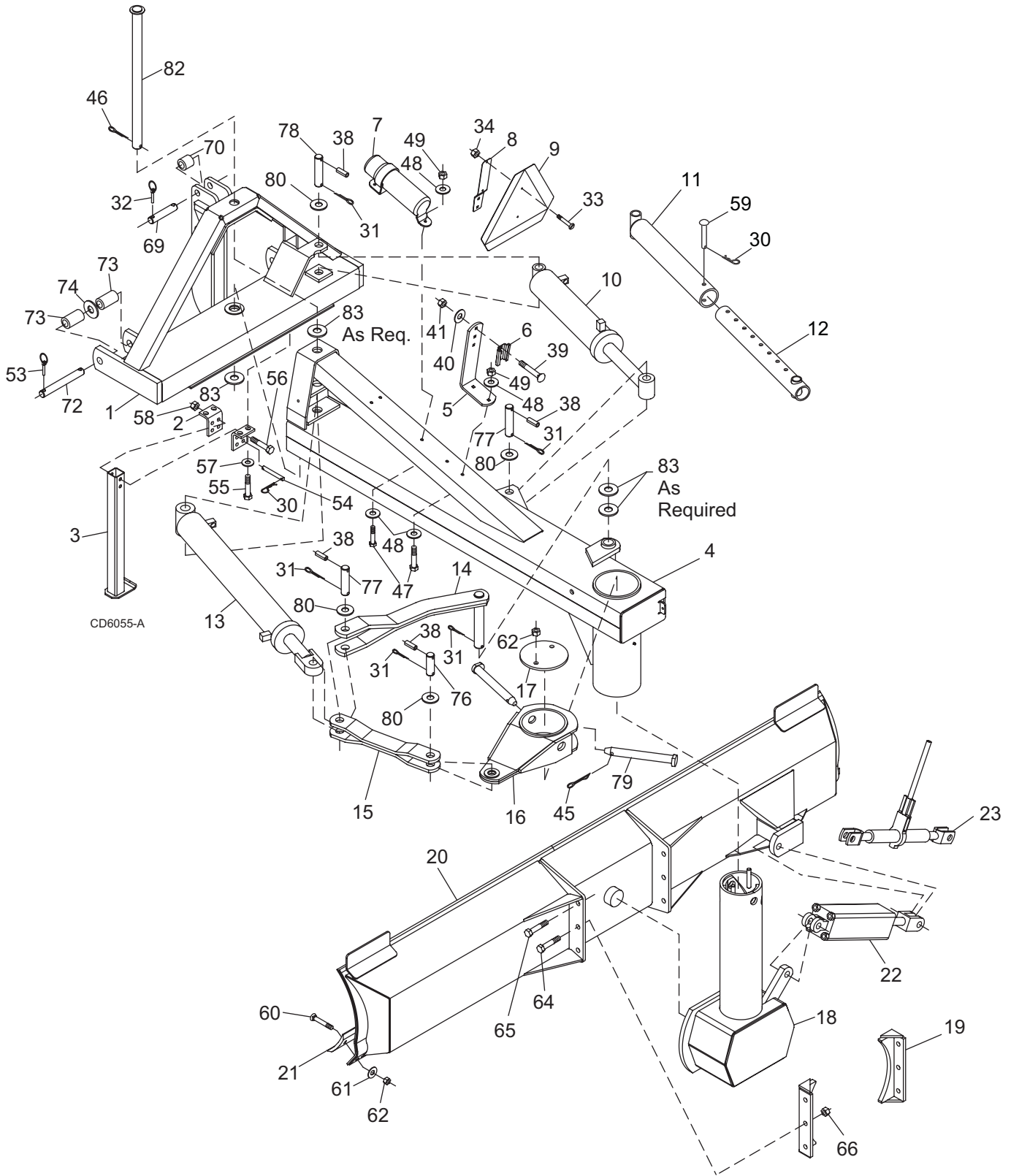

- 24 - Decal Set, Safety RB990/1010
- 25 - Decal Set, Complete RB990/1010

RB990-2 / RB1010-2 MAIN ASSEMBLY PARTS LIST

REF	PART	QTY	DESCRIPTION	REF	PART	QTY	DESCRIPTION
1	1005013	1	A-Frame	40	4378	2*	5/16 Flat washer, standard
2	26099	2	Parking stand bracket	41	6778	8*	5/16 NC Nut Lock
3	26095	1	Parking stand	45	3282	2	3/8 X 1-1/2 Clinch Pin
4	1005014	1	Boom assembly	46	744	1*	3/8 X 2-1/2 Cotter Pin
5	1004262	1	Bracket - SMV Sign	47	12169	5*	3/8 NC X 1-1/4 Hex head cap screw GR5
6	62484	1	Socket SMV Emblem	48	565	10*	3/8 Flat washer, standard
7	1003828	1	Manual Tube	49	6698	3*	3/8 NC Nut lock
8	1004251	1	SMV Bracket	53	27542	4	7/16 x 2 Klik Pin
9	24611	1	SMV Sign	54	13817	1	1/2 x 4-1/2 Clevis Pin
10	1005016	1	Hyd Cylinder 4.00 x 2.00 x 16.00	55	6100	4*	1/2 NC x 1-1/4 Hex head cap screw GR5
11	31971	1	Outer offset link	56	1637	1*	1/2 NC x 3-1/2 Hex head cap screw GR5
12	31973	1	Inner offset link	57	3598	4*	1/2 SAE Flat washer
13	1005015	1	Hyd Cylinder 4.00 x 2.00 x 30.00	58	765	1*	Nut Lock 1/2 NC Zp
14	1004267	1	Guide Link - Rear Blade	59	26431	3	9/16 x 4 Rivet pin
15	26082	1	Connecting link assembly	60	26920	10	5/8 NC x 1-3/4 Bolt plow GR5
16	26075	1	Angling crank assembly				or
17	26103	1	Retaining Cap	60	26169	†	5/8 NC x 2-1/2 Bolt Plow GR5
18	26034	1	Pivot Assembly	61	1517	†	.625 x 1.38 x 7 Ga Flat washer
19	26090	2	Retaining Bracket	62	6239	14*	5/8 NC Nut lock
20	1004889	1	RB990-2 Moldboard Assembly (Includes Cutting Edge)	64	300517	2*	3/4 NC x 1-3/4 Hex head cap screw GR5
			or	65	13759	4*	3/4 NC x 2-1/4 Hex head cap screw GR5
20	1004890	1	RB1010-2 Moldboard Assembly (Includes Cutting Edge)	66	2371	6*	3/4 NC Nut Lock
21	26068	1	RB990-2 Cutting edge 1/2 X 6	69	26148	1	1 x 4-29/32 Clevis pin HT
			or	70	14695	1	1 x 1-1/4 x 2 Sleeve
21	26074	1	RB1010-2 Cutting edge 1/2 X 6	72	26102	2	1-1/8 x 9 Mounting pin
22	1003197	1	Hyd Cylinder 3.5 x 1.25 x 10.0	73	26100	4	1-1/8 x 1-7/16x 2-5/8 Sleeve
23	1005020	1	Ratchet	74	23278	2	1-1/8 x 1-7/8 x 1/4 Flat washer
24	1004910		Safety decal set	76	26043	1	1-1/4 x 3-3/4 Clevis pin
25	1004911		Complete decal set	77	26088	2	1-1/4 x 6 Clevis pin
30	18270	3*	3/16 Safety Pin	78	26089	1	1-1/4 x 7-3/8 Clevis pin
31	6185	5*	1/4 X 2-1/4 Cotter Pin	79	26079	2	Index pin Assembly
32	62043	2*	1/4 X 1-3/4 Klik Pin	80	23609	4	1-1/4 x 2-3/8 x 3/16 Flat washer
33	1282	2*	1/4 NC X 1/2 Round head screw	82	26093	1	1-1/2 x 26-1/4 Pin Assembly
34	5288	2*	1/4 NC Hex nut	83	2370	7	1.62 x 3 x .18 Washer
38	11880	4*	5/16x 1-3/4 Spirol pin				
39	24409	2*	5/16 NC X 1 Carriage bolt				

* Standard Hardware, Obtain Locally

† For center holes
(1 for RB990-2 & 2 for RB1010-2)

RB990MA-2 / RB1010MA-2 ANGLE CYLINDER (MAIN ASSEMBLY)

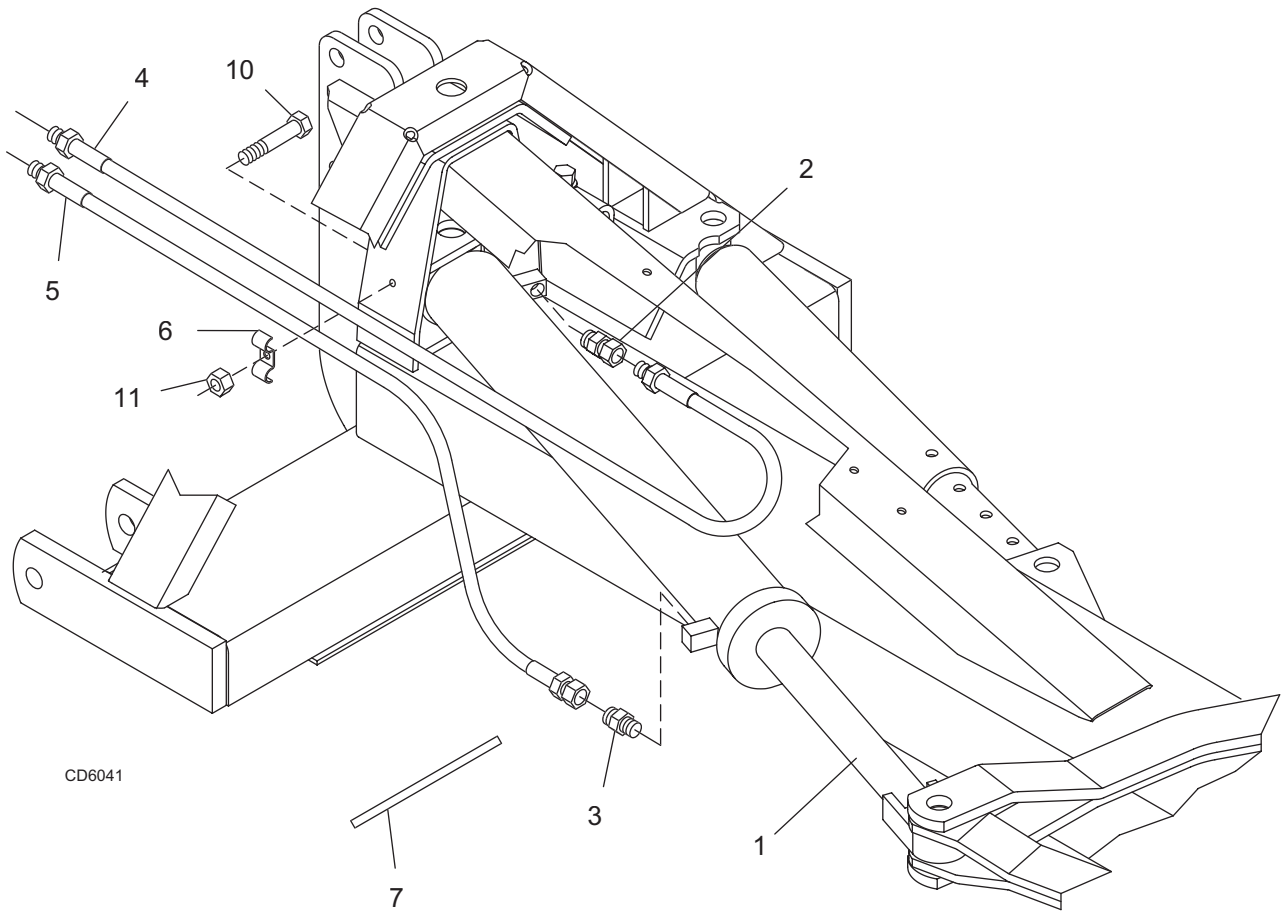

REF	PART	QTY	DESCRIPTION
1	1005015	1	Hyd Cylinder 4 x 30
2	315049	1	3/4 JICF 3/4 ORBM adapter
3	61	1	3/4 JICM 3/4 ORBM adapter
4	360166	1	Hose, 3/8 96 1/2 NPTM 3/4 JICM
5	1004856	1	Hose, 3/8 108 1/2 NPTM 3/4 JICF
6	56	1	Feedline Hose Clamp- 5/8
7	65766	4*	34" Binding Strap
10	6096	1*	5/16 NC x 3/4 Hex head cap screw GR5
11	6778	1*	5/16 NC Lock nut

* Standard Hardware;
Obtain Locally

HYDRAULIC TILT KIT 1004908 (OPTIONAL)

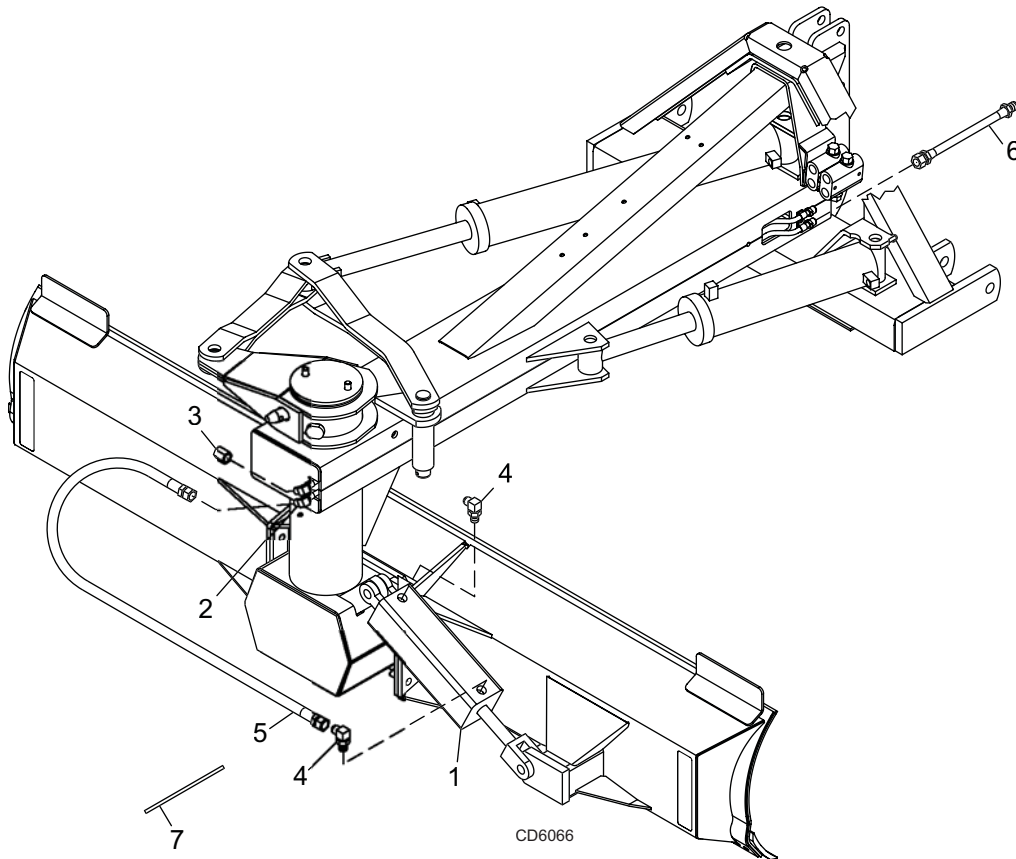

REF	PART	QTY	DESCRIPTION
1	1003197	1	Hyd Cylinder 3.5 x 1.25 x 10.0
2†	1003192	2	Tube Assembly - Rear Blade
3†	1004844	4	Cap, 3/4 JICF (for shipping only)
4	316004	2	Elbow, 3/4 ORBM 3/4 JICM 90
5	1004854	2	Hose, 3/8 45 3/4 JICF 3/4 JICF
6	1004283	2	Hose, 3/8 66 1/2 NPTM 3/4 JICF
7	8641	3*	14-1/2 Binding strap

- * Standard Hardware;
Obtain Locally
- † From main assembly,
not included in this kit.

RB990H-2 / RB1010H-2 HYDRAULIC CONFIGURATION

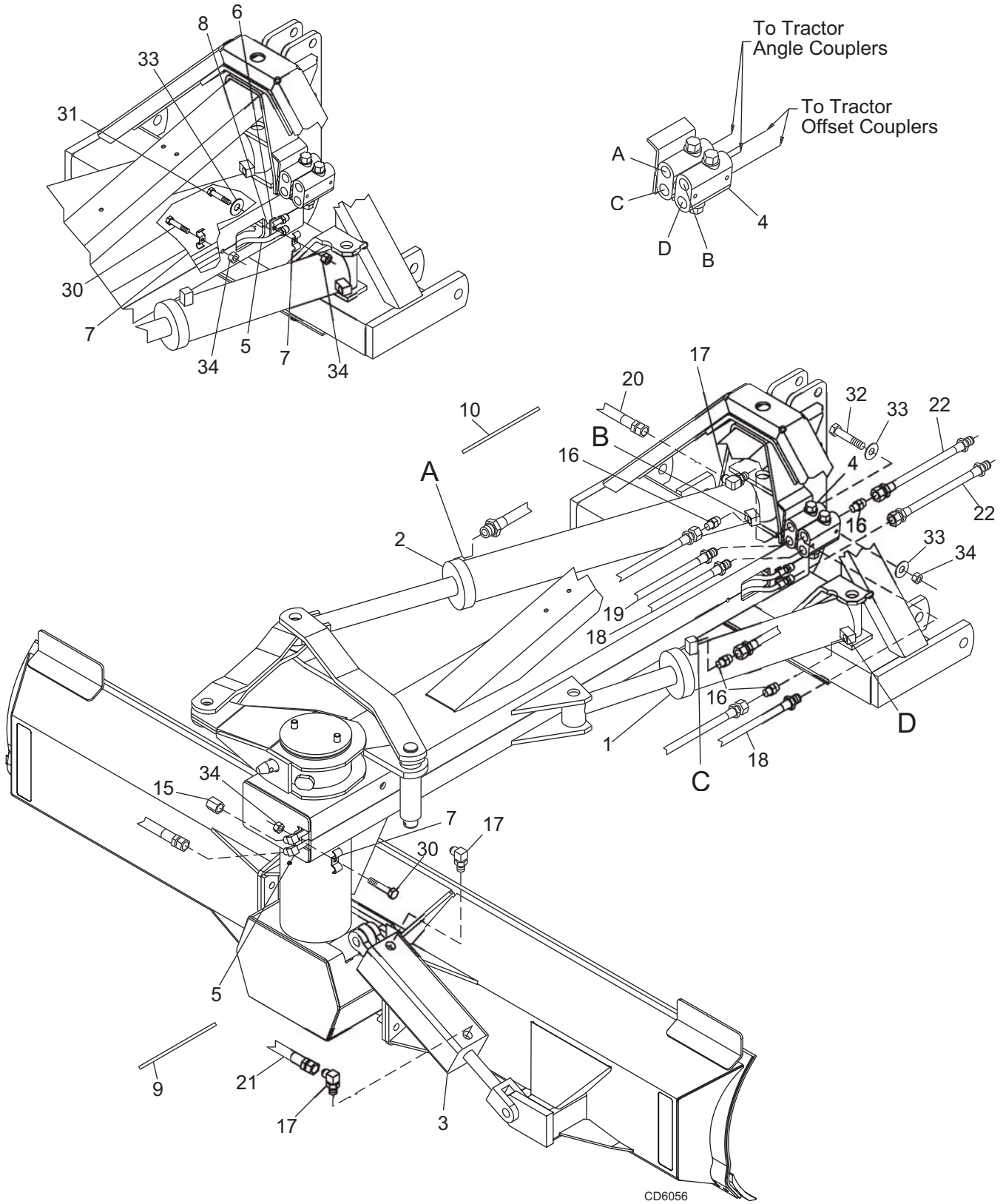

42 Parts

MAN0161 (Rev. 9/16/2005)

RB990H-2 / RB1010H-2 HYDRAULIC CONFIGURATION PARTS LIST

REF	PART	QTY	DESCRIPTION	REF	PART	QTY	DESCRIPTION
1	1005016	1	Hyd Cylinder 4.00 x 2.00 x 16.00	19	360160	1	Hose, 3/8 30 3/4 ORBM 3/4 JICF
2	1005015	1	Hyd Cylinder 4.00 x 2.00 x 30.00	20	1004855	1	Hose, 3/8 40 3/4 ORBM 3/4 JICF
3	1003197	1	Hyd Cylinder 3.5 x 1.25 x 10.0	21	1004854	2	Hose, 3/8 45 3/4 JICF 3/4 JICF
4	1004260	2	Valve, Hyd Double Relief 1600 psi	22	1004283	6	Hose, 3/8 66 1/2 NPTM 3/4 JICF
5	1003192	2	Tube Assembly - Rear Blade	30	14562	2*	5/16 NC x 1 Hex head cap screw GR5
6	1004843	1	Lug, Hyd Line	31	4528	1*	5/16 NC x 1-3/4 Hex head cap screw GR5
7	258	3	Feed Line Clamp 1/2	32	58423	2*	5/16 NC x 5 Hex head cap screw GR5
8	65516	1	Sleeve, .36 x .54 x .62	33	4378	8*	5/16 Flat washer, Standard
9	8641	*4	14-1/2 Binding strap	34	6778	5*	5/16 NC Lock nut
10	65766	*1	34 Binding strap				
15	1004844	4	Cap, 3/4 JICF (for shipping only)				
16	61	7	Adapter, 3/4 JICM 3/4 ORBM				
17	316004	3	Elbow, 3/4 ORBM 3/4 JICM 90				
18	360203	2	Hose, 3/8 24 3/4 ORBM 3/4 JICF				

* Standard Hardware;
Obtain Locally

SELECTOR VALVE 1004261 RELIEF VALVE 1004260

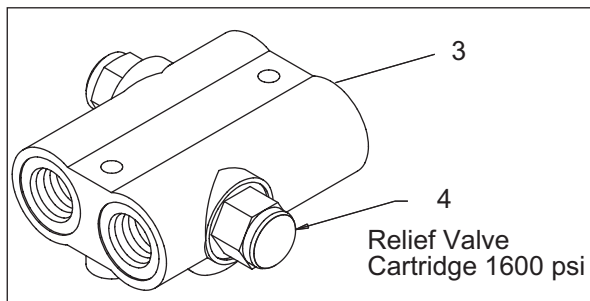

REF	PART	QTY	DESCRIPTION
A	1004261		Valve, Hyd Double Selector
1	1004295	1	Seal Kit, Double Selector Valve
2	1004296	1	Kit, Selector Valve Handle
3	1004260	1	Valve, Hyd Double Relief 1600 psi
4	1004297	1	Valve, Relief 1600 psi

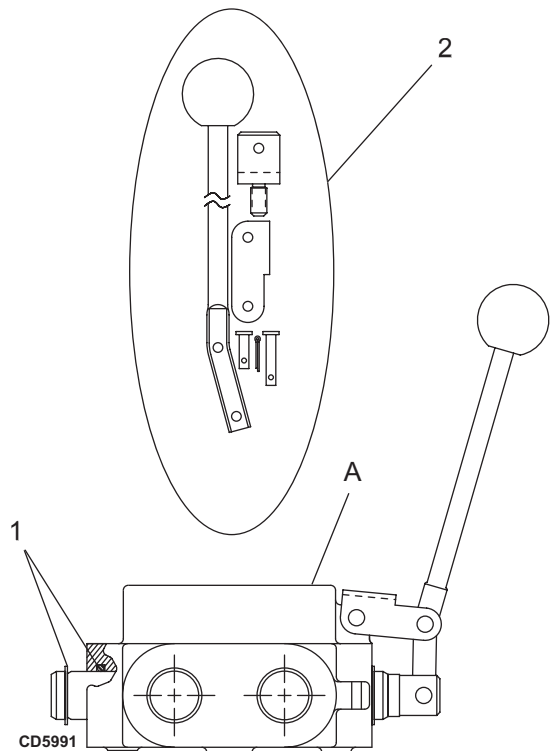

HYDRAULIC OFFSET KIT 1004907 (OPTIONAL)

REF	PART	QTY	DESCRIPTION
1	1005016	1	Hyd Cylinder 4.00 x 2.00 x 16.00
2	1005015	1	Hyd Cylinder 4.00 x 2.00 x 30.00
3	1004260	2	Valve, Hyd Double Relief 1600 psi
4	8641	4*	14-1/2 Binding strap
5	65766	1*	34 Binding strap
16	61	7	Adapter, 3/4 JICM 3/4 ORBM
17	316004	1	Elbow, 3/4 ORBM 3/4 JICM 90
18	360203	2	Hose, 3/8 24 3/4 ORBM 3/4 JICF
19	360160	1	Hose, 3/8 30 3/4 ORBM 3/4 JICF
20	1004855	1	Hose, 3/8 40 3/4 ORBM 3/4 JICF
21	1004283	4	Hose, 3/8 66 1/2 NPTM 3/4 JICF
32	58423	2*	5/16 NC x 5 Hex head cap screw GR5
33	4378	4*	5/16 Flat washer, Standard
34	6778	2*	5/16 NC Lock nut

* Standard Hardware;
Obtain Locally

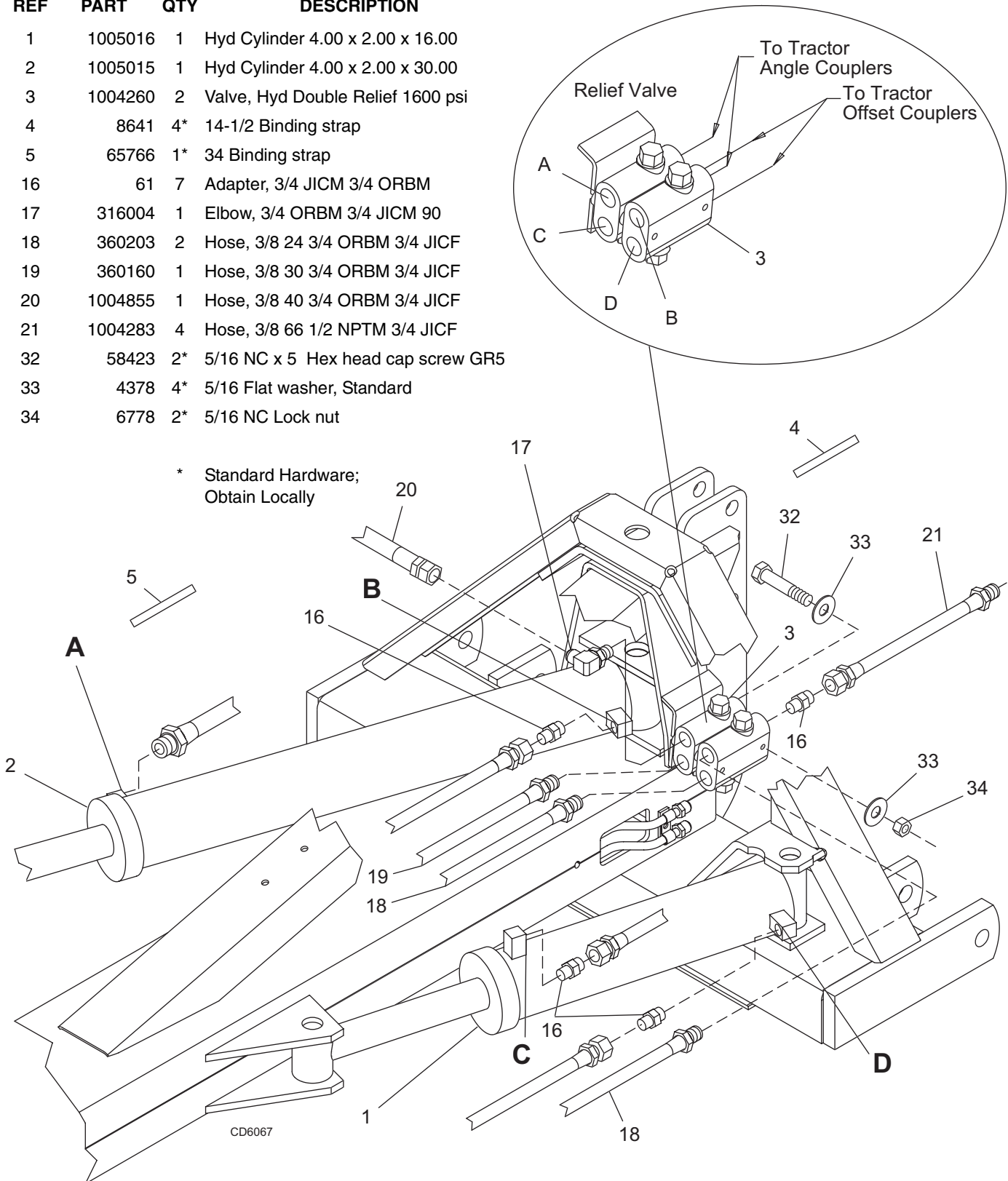

44 Parts

MAN0161 (Rev. 9/16/2005)

SELECTOR VALVE KIT 1004909 (OPTIONAL)

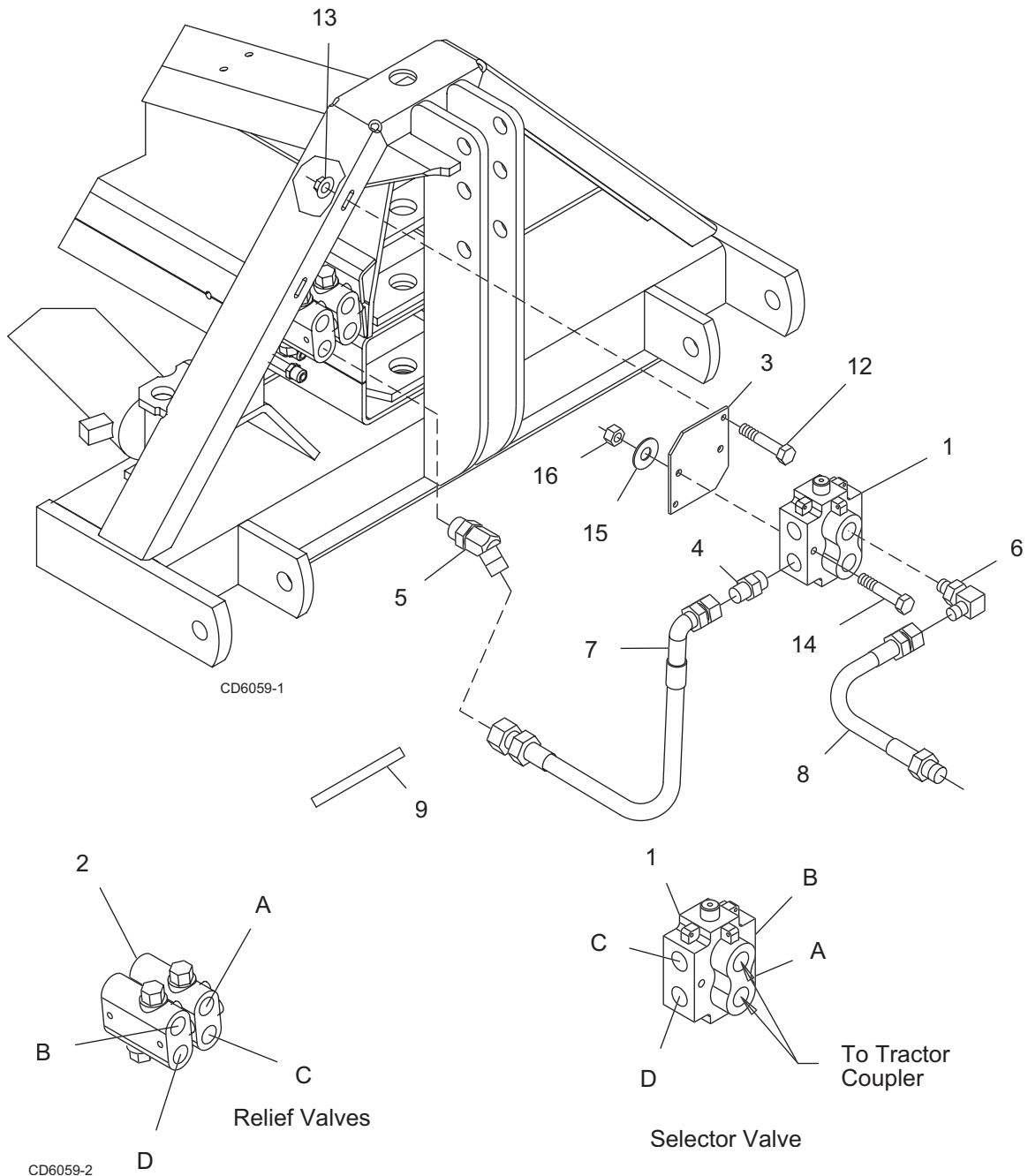

REF	PART	QTY	DESCRIPTION	REF	PART	QTY	DESCRIPTION
1	1004261	1	Valve, Hyd Double Selector	12	14562	2*	5/16 NC x 1 Cap screw GR5
2†	1004260	2	Valve, Hyd Double Relief 1600 psi	13	14139	5	5/16 NC Flanged Lock Nut
3	26105	1	Valve mounting bracket	14	7747	1*	3/8 NC x 3 Cap screw GR5
4	316017	4	Adapter, 3/4 JICM 1-1/16 ORBM	15	565	2*	3/8 Flat washer, Standard
5	1004288	4	Elbow, Hyd 3/4 JICM 3/4 ORBM 45	16	6698	2*	3/8 NC Lock nut
6	37501	2	Elbow, 3/4 JICM 1-1/16 ORBM 90				
7	1004898	4	Hose, 3/8 28 3/4 JICF 3/4 JICF				* Standard Hardware; Obtain Locally
8	1004283	2	Hose, 3/8 66 1/2 NPTM 3/4 JICF				† From RB990H/1010H or Offset Kit
9	8641	3*	14-1/2 Binding strap				

3.5" HYDRAULIC CYLINDER ASSEMBLY & PARTS LIST

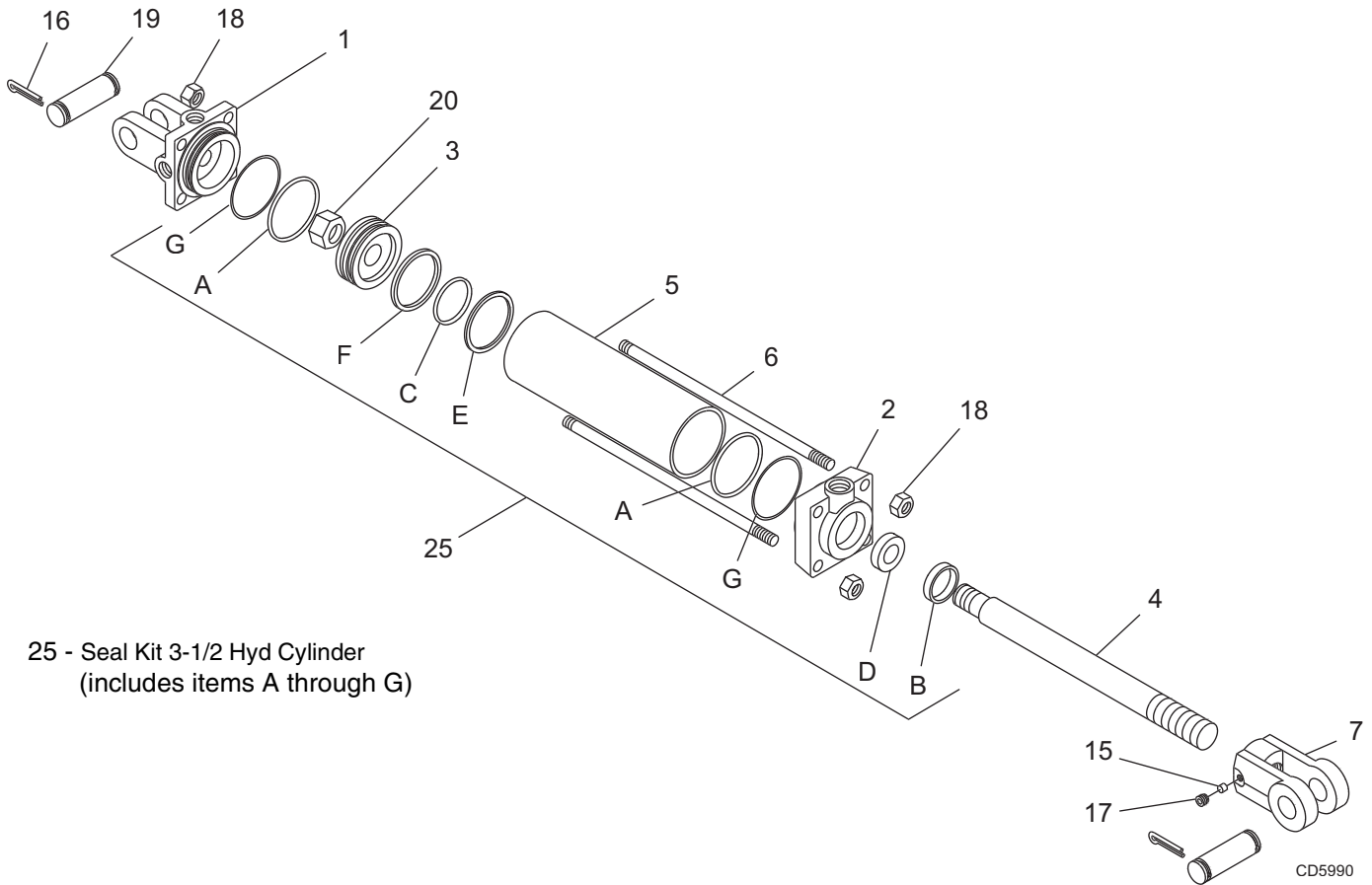

25 - Seal Kit 3-1/2 Hyd Cylinder
(includes items A through G)

REF	PART	QTY	DESCRIPTION	REF	PART	QTY	DESCRIPTION
A	1003197		Cylinder, Hyd 3-1/2 x 10 (Tilt)	25	1005000		Seal Kit 3-1/2 Hyd Cylinder (Includes Items A - G)
1	N/S	1	Clevis Cap	A		2	O-Ring
2	N/S	1	Rod Cap	B		1	Rod Wiper
3	1004826	1	Piston, 3-1/2 Hyd Cylinder	C		1	O-Ring (Piston Seal Expander)
4	1004829	1	Rod, Hyd Cylinder 1.25	D		1	Rod Seal
5	N/S	1	Tube	E		1	Piston Seal
6	N/S	4	Tie Rod	F		2	Piston Wear Ring
7	1004827	1	Clevis, Hyd Cylinder Rod	G		2	Backup Washer
15	N/S	1	Nylon Thread Patch			N/S	Not Serviced Separately
16	1266	4*	3/16 x 1-1/2 Cotter pin			*	Standard Hardware; Obtain Locally
17		1*	Screw, Set 3/8 NC x 1/2 (Torque to 20 lbs-ft)				
18	302176	8*	Nut, Hex 5/8 UNF (Torque to 160 lbs-ft)				
19	1631	2	Pin, Headless 1.00 x 3.63				
20	34323	1	Nut, Hex Lock 1-14 UNS (Torque to 300 lbs-ft)				

46 Parts

MAN0161 (Rev. 9/16/2005)

4.0" HYDRAULIC CYLINDER ASSEMBLY & PARTS LIST

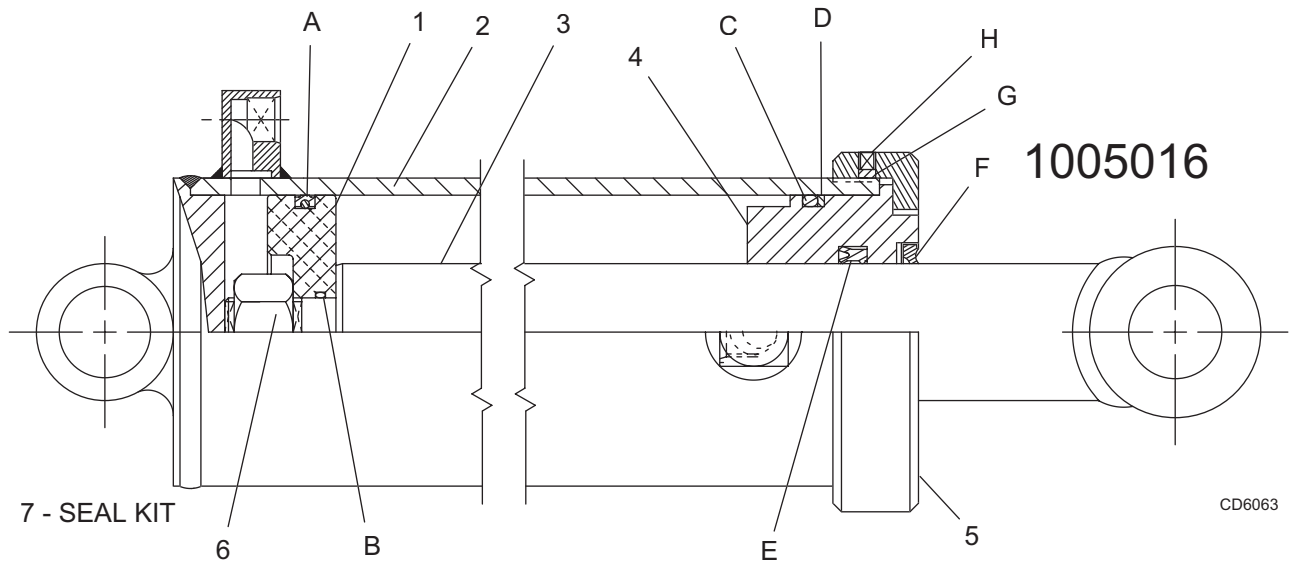
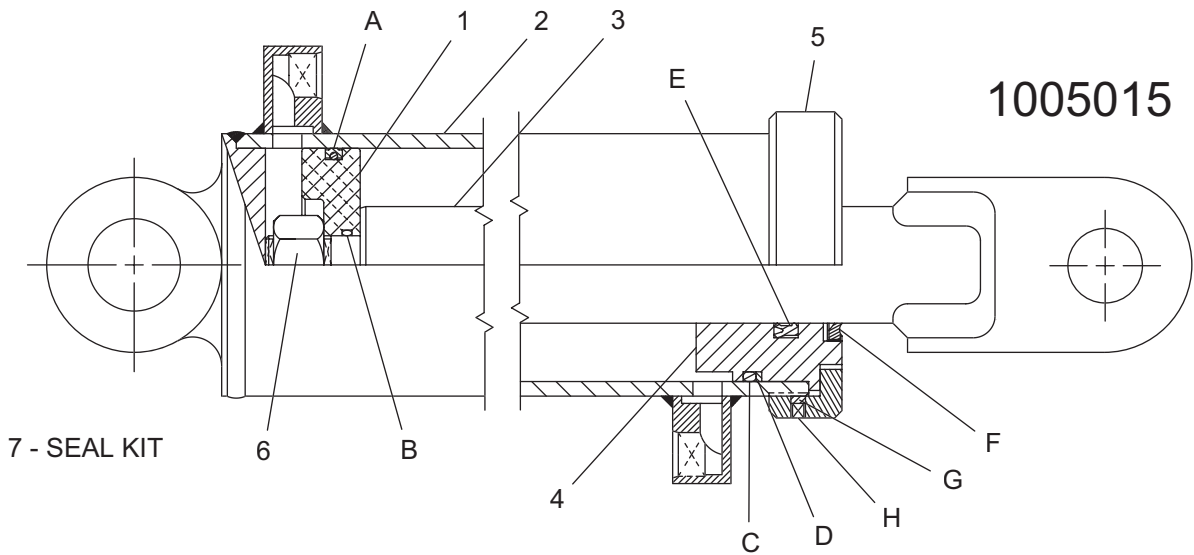

REF	PART	QTY	DESCRIPTION	REF	PART	QTY	DESCRIPTION
A	1005015	1	Hyd Cylinder 4.00 x 2.00 x 30.00	7	1004289	1	Seal Kit - 4.0 Dia Hyd Cylinder (Includes Items A - H)
A	1005016	1	Hyd Cylinder 4.00 x 2.00 x 16.00	A		1	Crown Seal
1	1004290	1	Piston, 4.00 OD x 1.00 ID	B		1	O-Ring
2	N/S	1	Tube Assembly	C		1	O-Ring
3	1004291	1	Rod, 2.0 x 38.6 (for 1005015) or	D		1	Backup
3	1004294	1	Rod, 2.0 x 23.9 (for 1005016)	E		1	U-Cup Seal
4	1004292	1	Head gland 4.0 OD x 4.0 ID	F		1	Rod Wiper
5	1004293	1	Head cap 5.25 OD (Torque to 320 lbs-ft)	G		1	Nylon Ball
6	34323	1	Hex lock nut 1-14 UNS (Torque to 320 lbs-ft)	H		1	Set Screw 1/4 NC x 1/4 CP
							N/S Not Serviced Separately

PNEUMATIC TAIL WHEEL KIT 29399

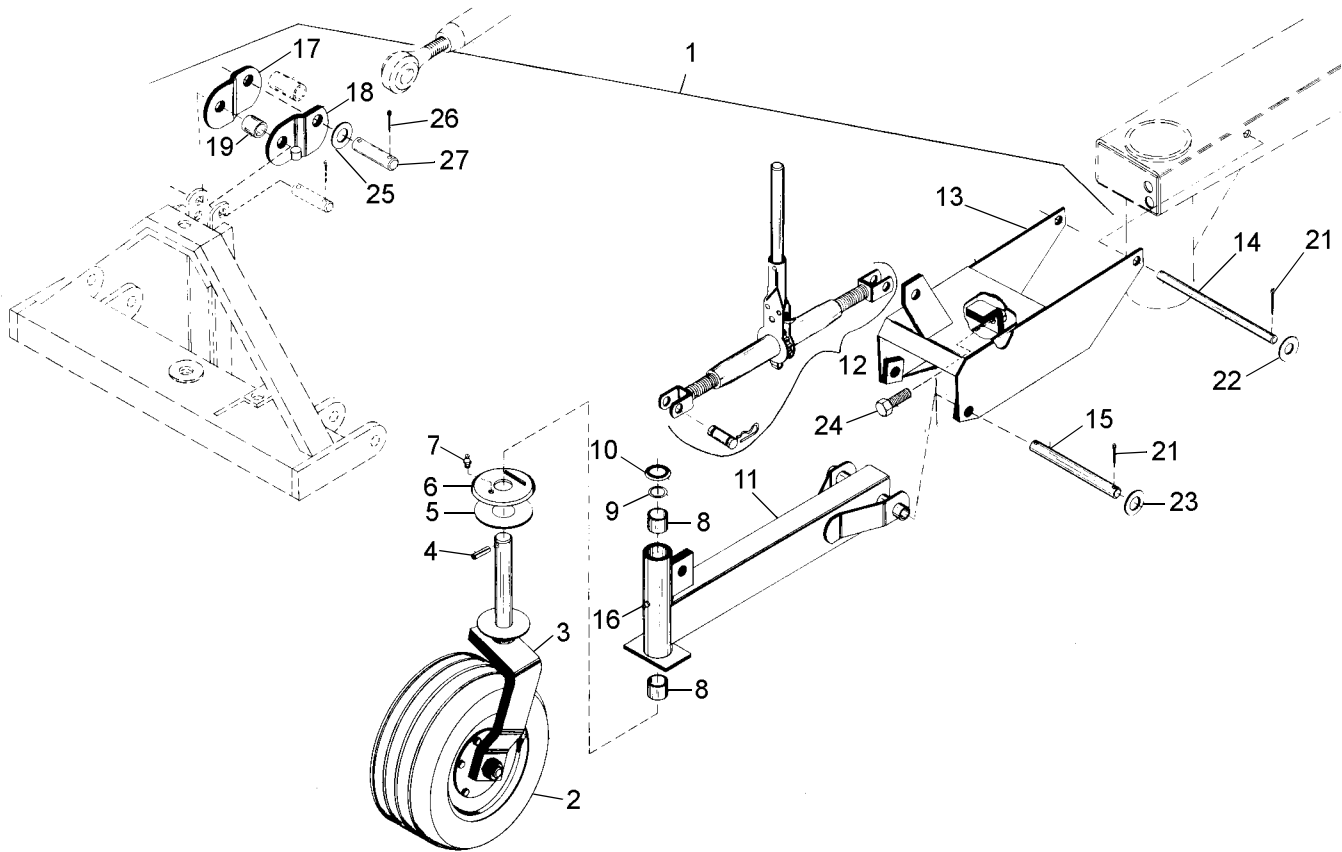

REF	PART	QTY	PART	REF	PART	QTY	DESCRIPTION
1	29399	1	Tail Wheel, Pneumatic Complete	15	28789	1	1 x 12-1/4 Clevis pin
2	—	1	Tire, Wheel & Hub	16	1972	1*	Grease Fitting, 1/4-28 Tapered Thread
3	14125	1	Wheel Yoke Assembly	17	29031	1	Floating link, Left
4	7276	1*	Spirol pin 7/16 x 2-1/2	18	29030	1	Floating link, Right
5	19459	1	Friction disc 4 x 6.15	19	29034	1	Sleeve, 1.00 x 1.25 x 1.44
6	14135	1	Top Dampener plate	21	1285	4*	1/4 x 1-1/2 Cotter pin
7	195	1*	Grease Fitting, 1/8 Pipe Thread	22	1257	2*	3/4 Flat washer, Standard
8	11011	2	Bushing, Bronze 1.50 x 1.63 x 1.50	23	832	2*	1 Flat washer, Standard
9	12889	1	O-Ring .09 x 1.56 OD	24	24576	1*	1/2 NC x 1-3/4 Hex head cap screwGR5
10	12881	1	Dust cap	25	1863	2*	1 Flat washer, Standard
11	28776	1	Tail Wheel Arm Assembly	26	6185	2*	1/4 x 2-1/4 Cotter pin
12	1005020	1	Ratchet	27	26148	1	1 x 4-29/32 Clevis pin HT
13	28790	1	Tail Wheel Bracket Assembly				
14	28788	1	3/4 x 12-1/4 Clevis pin				

* Standard Hardware;
Obtain Locally

48 Parts

MAN0161 (Rev. 9/16/2005)

WHEEL HUB, TIRE & WHEEL ASSEMBLY

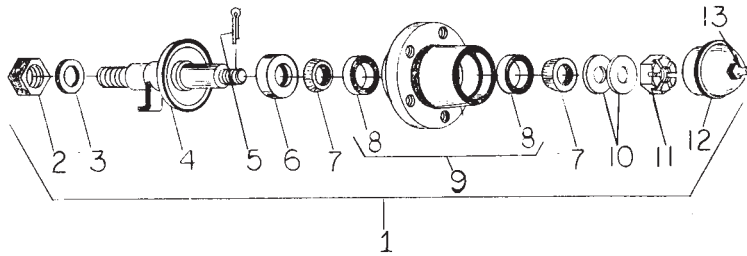

DB-418

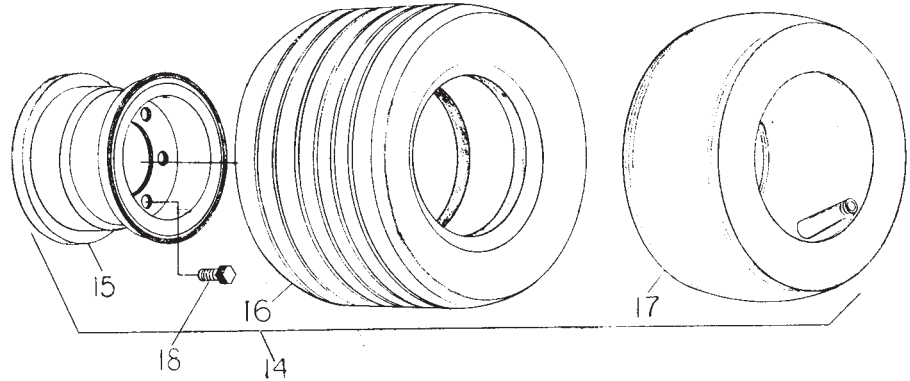

TIRE INFLATION: 45 LBS.

REF	PART	QTY	DESCRIPTION	REF	PART	QTY	DESCRIPTION
1	14130	1	Wheel Hub & Axle Assembly	10	1257	2*	3/4 Flat washer, Standard
2	3626	1	Nut, Hex 1-14 UNS	11	5849	1	Nut, Slotted Hex 3/4 NF
3	1863	1*	1 Flat washer, Standard	12	14133	1	Hub Cap Assembly w/fitting
4	14131	1	Axle Assembly	13	6270	1*	Grease Fitting, 1/4 Tapered Thread
5	1266	1*	3/16 x 1-1/2 Cotter pin	14	14255	1	Wheel & Tire 18 x 9.5 - 8
6	314	1	Seal, 1.50 x 2.44 x .31 (Note: Point spring-loaded lip outward when assembling seal to housing)	15	14256	1	Rim 18 x 9.5 x 8
7	2303	2	Bearing Cone	16	N/S	1	Tire, Rib 18 x 9.5 x 8 6-ply
8	2305	2	Bearing Cup	17	N/S	1	Inner Tube, 18 x 9.50 x 8
9	14132	1	Wheel Hub, Housing w/cups	18	1258	5	Bolt, Wheel 1/2 NF x 1-1/8
							N/S Not Serviced Separately
							* Standard Hardware; Obtain Locally

BOLT TORQUE CHART

Always tighten hardware to these values unless a different torque value or tightening procedure is listed for a specific application.

Fasteners must always be replaced with the same grade as specified in the manual parts list.

Always use the proper tool for tightening hardware: SAE for SAE hardware and Metric for metric hardware.

Make sure fastener threads are clean and you start thread engagement properly.

All torque values are given to specifications used on hardware defined by SAE J1701 MAR99 & J1701M JUL96.

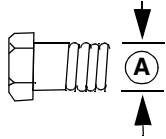

SAE SERIES TORQUE CHART

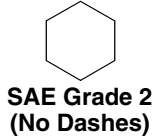

SAE Bolt Head Identification



A Diameter (Inches)	Wrench Size	MARKING ON HEAD					
		SAE 2		SAE 5		SAE 8	
		lbs-ft	N-m	lbs-ft	N-m	lbs-ft	N-m
1/4"	7/16"	6	8	10	13	14	18
5/16"	1/2"	12	17	19	26	27	37
3/8"	9/16"	23	31	35	47	49	67
7/16"	5/8"	36	48	55	75	78	106
1/2"	3/4"	55	75	85	115	120	163
9/16"	13/16"	78	106	121	164	171	232
5/8"	15/16"	110	149	170	230	240	325
3/4"	1-1/8"	192	261	297	403	420	569
7/8"	1-5/16"	306	416	474	642	669	907
1"	1-1/2"	467	634	722	979	1020	1383

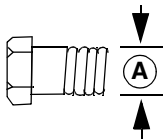

METRIC SERIES TORQUE CHART

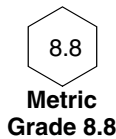

Metric Bolt Head Identification

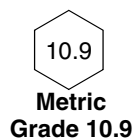

A Diameter & Thread Pitch (Millimeters)	Wrench Size	COARSE THREAD				FINE THREAD				A Diameter & Thread Pitch (Millimeters)
		MARKING ON HEAD				MARKING ON HEAD				
		Metric 8.8		Metric 10.9		Metric 8.8		Metric 10.9		
		N-m	lbs-ft	N-m	lbs-ft	N-m	lbs-ft	N-m	lbs-ft	
6 x 1.0	10 mm	8	6	11	8	8	6	11	8	6 x 1.0
8 x 1.25	13 mm	20	15	27	20	21	16	29	22	8 x 1.0
10 x 1.5	16 mm	39	29	54	40	41	30	57	42	10 x 1.25
12 x 1.75	18 mm	68	50	94	70	75	55	103	76	12 x 1.25
14 x 2.0	21 mm	109	80	151	111	118	87	163	120	14 x 1.5
16 x 2.0	24 mm	169	125	234	173	181	133	250	184	16 x 1.5
18 x 2.5	27 mm	234	172	323	239	263	194	363	268	18 x 1.5
20 x 2.5	30 mm	330	244	457	337	367	270	507	374	20 x 1.5
22 x 2.5	34 mm	451	332	623	460	495	365	684	505	22 x 1.5
24 x 3.0	36 mm	571	421	790	583	623	459	861	635	24 x 2.0
30 x 3.0	46 mm	1175	867	1626	1199	1258	928	1740	1283	30 x 2.0

Typical Washer Installations

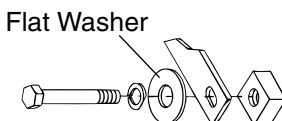
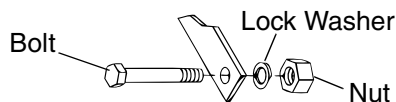

8/9/00

BOLT SIZE CHART

NOTE: Chart shows bolt thread sizes and corresponding head (wrench) sizes for standard SAE and metric bolts.

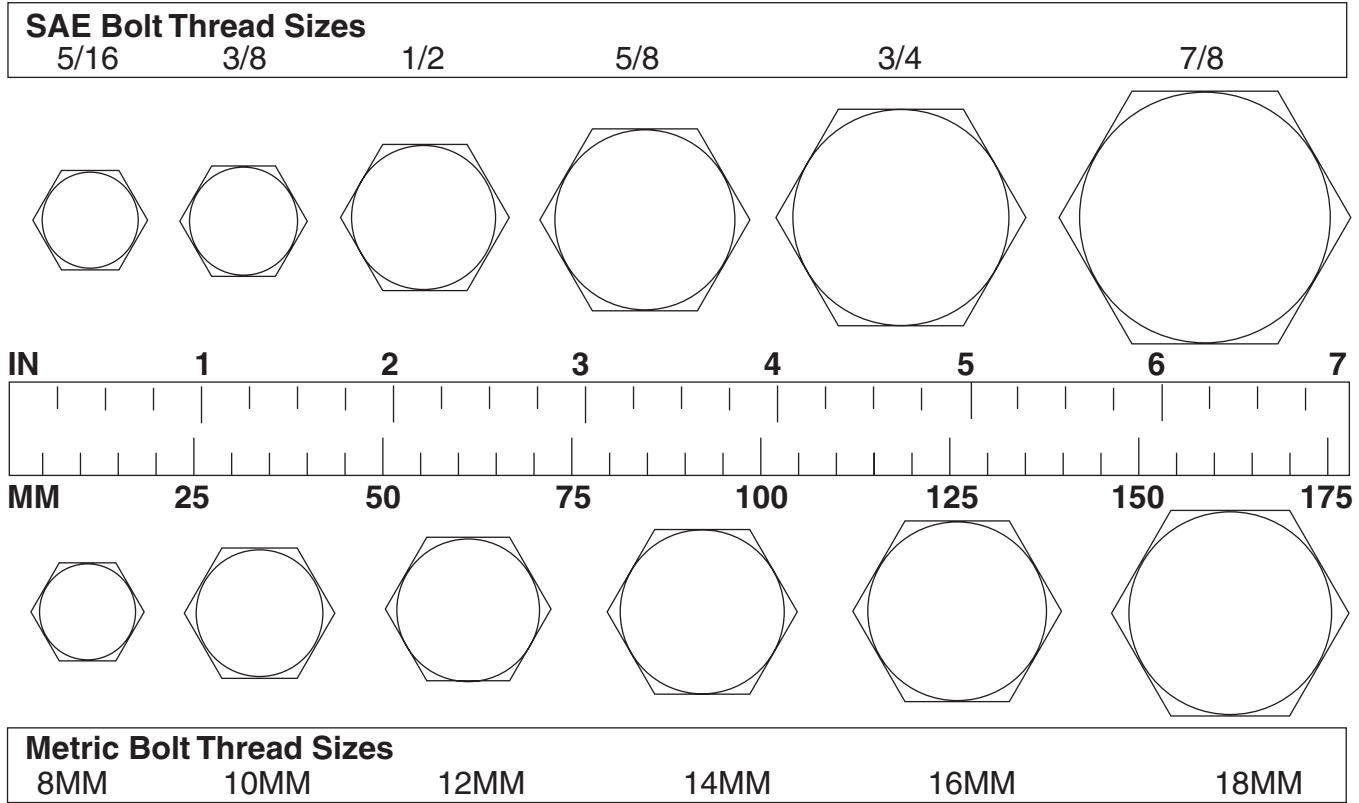

ABBREVIATIONS

AG.....Agriculture	NC.....National Coarse
ATF.....Automatic Transmission Fluid	NF.....National Fine
BSPP.....British Standard Pipe Parallel	NPSM.....National Pipe Straight Mechanical
BSPTM.....British Standard Pipe Tapered Male	NPT.....National Pipe Tapered
CV.....Constant Velocity	NPT SWF.....National Pipe Tapered Swivel Female
CCW.....Counter-Clockwise	ORBM.....O-Ring Boss - Male
CW.....Clockwise	P.....Pitch
F.....Female	PBY.....Power-Beyond
GA.....Gauge	psi.....Pounds per Square Inch
GR (5, etc.).....Grade (5, etc.)	PTO.....Power Take Off
HHCS.....Hex Head Cap Screw	QD.....Quick Disconnect
HT.....Heat-Treated	RH.....Right Hand
JIC.....Joint Industry Council 37° Degree Flare	ROPS.....Roll-Over Protective Structure
LH.....Left Hand	RPM.....Revolutions Per Minute
LT.....Left	RT.....Right
m.....Meter	SAE.....Society of Automotive Engineers
mm.....Millimeter	UNC.....Unified Coarse
M.....Male	UNF.....Unified Fine
MPa.....Mega Pascal	UNS.....Unified Special
N.....Newton	



WARRANTY

(All Models Except Mow'n Machine™ Zero-Turn Mowers and Woods Boundary™ Utility Vehicles)

Please Enter Information Below and Save for Future Reference.

Date Purchased: _____

From (Dealer): _____

Model Number: _____

Serial Number: _____

Woods Equipment Company ("WOODS") warrants this product to be free from defect in material and workmanship. Except as otherwise set forth below, the duration of this Warranty shall be for TWELVE (12) MONTHS COMMENCING ON THE DATE OF DELIVERY OF THE PRODUCT TO THE ORIGINAL PURCHASER.

The warranty periods for certain gearboxes are listed below:

Model No.	Part Warranted	Duration
PHD25, PHD35, PHD65, PHD95, 1260, 2120, 2162, 3180, 3240, BB48, BB60, BB72, BB84, BB600, BB720, BB840, BB6000, BB7200, BB8400, BW180, DS96, DS120, RCC42, RM550-2, RM660-2, RM990-3, RD6000-2, RD7200-2, RD8400-2, 7144RD-2, 9180RD-2, 9204RD-2	Gearbox components	5 years from the date of delivery to the original purchaser.
RDC54, RD60, RD72	Gearbox components	3 years from the date of delivery to the original purchaser.
BW180, DS96, DS120, RDC54, RD60, RD72	Gearbox components	1 year from the date of delivery to the original purchaser if used in rental or commercial applications.

Under no circumstances will this Warranty apply in the event that the product, in the good faith opinion of WOODS, has been subjected to improper operation, improper maintenance, misuse, or an accident. This Warranty does not apply in the event that the product has been materially modified or repaired by someone other than WOODS, a WOODS authorized dealer or distributor, and/or a WOODS authorized service center. This Warranty does not cover normal wear or tear, or normal maintenance items. This Warranty also does not cover repairs made with parts other than those obtainable through WOODS.

This Warranty is extended solely to the original purchaser of the product. Should the original purchaser sell or otherwise transfer this product to a third party, this Warranty does not transfer to the third party purchaser in any way. There are no third party beneficiaries of this Warranty.

WOODS makes no warranty, express or implied, with respect to engines, batteries, tires or other parts or accessories not manufactured by WOODS. Warranties for these items, if any, are provided separately by their respective manufacturers.

WOODS' obligation under this Warranty is limited to, at WOODS' option, the repair or replacement, free of charge, of the product if WOODS, in its sole discretion, deems it to be defective or in noncompliance with this Warranty. **The product must be returned to WOODS with proof of purchase within thirty (30) days after such defect or noncompliance is discovered or should have been discovered, routed through the dealer and distributor from whom the purchase was made, transportation charges prepaid.** WOODS shall complete such repair or replacement within a reasonable time after WOODS receives the product. THERE ARE NO OTHER REMEDIES UNDER THIS WARRANTY. THE REMEDY OF REPAIR OR REPLACEMENT IS THE SOLE AND EXCLUSIVE REMEDY UNDER THIS WARRANTY.

THERE ARE NO WARRANTIES WHICH EXTEND BEYOND THE DESCRIPTION ON THE FACE OF THIS WARRANTY. WOODS MAKES NO OTHER WARRANTY, EXPRESS OR IMPLIED, AND WOODS SPECIFICALLY DISCLAIMS ANY IMPLIED WARRANTY OF MERCHANTABILITY AND/OR ANY IMPLIED WARRANTY OF FITNESS FOR A PARTICULAR PURPOSE.

WOODS shall not be liable for any incidental or consequential losses, damages or expenses, arising directly or indirectly from the product, whether such claim is based upon breach of contract, breach of warranty, negligence, strict liability in tort or any other legal theory. Without limiting the generality of the foregoing, Woods specifically disclaims any damages relating to (i) lost profits, business, revenues or goodwill; (ii) loss of crops; (iii) loss because of delay in harvesting; (iv) any expense or loss incurred for labor, supplies, substitute machinery or rental; or (v) any other type of damage to property or economic loss.

This Warranty is subject to any existing conditions of supply which may directly affect WOODS' ability to obtain materials or manufacture replacement parts.

No agent, representative, dealer, distributor, serviceperson, salesperson, or employee of any company, including without limitation, WOODS, its authorized dealers, distributors, and service centers, is authorized to alter, modify, or enlarge this Warranty.

Answers to any questions regarding warranty service and locations may be obtained by contacting:

Woods Equipment Company

2606 South Illinois Route 2
Post Office Box 1000
Oregon, Illinois 61061

815-732-2141 tel
815-732-7580 fax
www.WoodsEquipment.com



ALITEC™

BMP®

CENTRAL FABRICATORS®

GANNON®

GILL®

WAIN-ROY®

WOODS®



WARRANTY

(Replacement Parts For All Models Except Mow'n Machine™
Zero-Turn Mowers and Woods Boundary™ Utility Vehicles)

Woods Equipment Company ("WOODS") warrants this product to be free from defect in material and workmanship for a period of ninety (90) days from the date of delivery of the product to the original purchaser with the exception of V-belts, which will be free of defect in material and workmanship for a period of 12 months.

Under no circumstances will this Warranty apply in the event that the product, in the good faith opinion of WOODS, has been subjected to improper operation, improper maintenance, misuse, or an accident. This Warranty does not cover normal wear or tear, or normal maintenance items.

This Warranty is extended solely to the original purchaser of the product. Should the original purchaser sell or otherwise transfer this product to a third party, this Warranty does not transfer to the third party purchaser in any way. There are no third party beneficiaries of this Warranty.

WOODS' obligation under this Warranty is limited to, at WOODS' option, the repair or replacement, free of charge, of the product if WOODS, in its sole discretion, deems it to be defective or in noncompliance with this Warranty. **The product must be returned to WOODS with proof of purchase within thirty (30) days after such defect or noncompliance is discovered or should have been discovered, routed through the dealer and distributor from whom the purchase was made, transportation charges prepaid.** WOODS shall complete such repair or replacement within a reasonable time after WOODS receives the product. THERE ARE NO OTHER REMEDIES UNDER THIS WARRANTY. THE REMEDY OF REPAIR OR REPLACEMENT IS THE SOLE AND EXCLUSIVE REMEDY UNDER THIS WARRANTY.

THERE ARE NO WARRANTIES WHICH EXTEND BEYOND THE DESCRIPTION ON THE FACE OF THIS WARRANTY. WOODS MAKES NO OTHER WARRANTY, EXPRESS OR IMPLIED, AND WOODS SPECIFICALLY DISCLAIMS ANY IMPLIED WARRANTY OF MERCHANTABILITY AND/OR ANY IMPLIED WARRANTY OF FITNESS FOR A PARTICULAR PURPOSE.

WOODS shall not be liable for any incidental or consequential losses, damages or expenses, arising directly or indirectly from the product, whether such claim is based upon breach of contract, breach of warranty, negligence, strict liability in tort or any other legal theory. Without limiting the generality of the foregoing, Woods specifically disclaims any damages relating to (i) lost profits, business, revenues or goodwill; (ii) loss of crops; (iii) loss because of delay in harvesting; (iv) any expense or loss incurred for labor, supplies, substitute machinery or rental; or (v) any other type of damage to property or economic loss.

This Warranty is subject to any existing conditions of supply which may directly affect WOODS' ability to obtain materials or manufacture replacement parts.

No agent, representative, dealer, distributor, service person, salesperson, or employee of any company, including without limitation, WOODS, its authorized dealers, distributors, and service centers, is authorized to alter, modify, or enlarge this Warranty.

Answers to any questions regarding warranty service and locations may be obtained by contacting:

Woods Equipment Company

2606 South Illinois Route 2
Post Office Box 1000
Oregon, Illinois 61061

815-732-2141 tel
815-732-7580 fax
www.WoodsEquipment.com

WOODS®

ALITEC™

BMP®

CENTRAL FABRICATORS®

GANNON®

GILL®

WAIN-ROY®

WOODS®

MAN0161

**Woods Equipment
Company**

2606 South Illinois Route 2
Post Office Box 1000
Oregon, Illinois 61061

815-732-2141 tel
815-732-7580 fax
www.WoodsEquipment.com

WOODS®

© 2002 Woods Equipment Company. All rights reserved. WOODS, the Woods logo, and "Tested. Proven. Unbeatable." are trademarks of Woods Equipment Company. All other trademarks, trade names, or service marks not owned by Woods Equipment Company that appear in this manual are the property of their respective companies or mark holders. Specifications subject to change without notice.