

ALITEC™

**SKID STEER
COLD PLANER**

**CP12LFA
12" Low Flow "A" Series**

**Effective Serial Numbers:
242340201 & Above**

MCPLFA

Rev. 7/4/2008

WOODS®
Tested. Proven. Unbeatable.

OPERATOR'S MANUAL

TO THE DEALER:

Assembly and proper installation of this product is the responsibility of the Woods® dealer. Read manual instructions and safety rules. Make sure all items on the Dealer's Pre-Delivery and Delivery Check Lists in the Operator's Manual are completed before releasing equipment to the owner.

The dealer must complete the Product Registration included with the Operator's Manual. The customer must sign the registration which certifies that all Dealer Check List items have been completed. The dealer is to return the prepaid postage portion to Woods, give one copy to the customer, and retain one copy. **Failure to complete and return this card does not diminish customer's warranty rights.**

TO THE OWNER:

Read this manual before operating your Woods equipment. The information presented will prepare you to do a better and safer job. Keep this manual handy for ready reference. Require all operators to read this manual carefully and become acquainted with all adjustment and operating procedures before attempting to operate. Replacement manuals can be obtained from your dealer. To locate your nearest dealer, check the Dealer Locator at www.WoodsEquipment.com, or in the United States and Canada call 1-800-848-3447.

The equipment you have purchased has been carefully engineered and manufactured to provide dependable and satisfactory use. Like all mechanical products, it will require cleaning and upkeep. Lubricate the unit as specified. Observe all safety information in this manual and safety decals on the equipment.

For service, your authorized Woods dealer has trained mechanics, genuine Woods service parts, and the necessary tools and equipment to handle all your needs.

Use only genuine Woods service parts. Substitute parts will void the warranty and may not meet standards required for safe and satisfactory operation. Record the model number and serial number of your equipment in the spaces provided:

Model: _____ **Date of Purchase:** _____

Serial Number: (see Safety Decal section for location) _____

Provide this information to your dealer to obtain correct repair parts.

Throughout this manual, the term **NOTICE** is used to indicate that failure to observe can cause damage to equipment. The terms **CAUTION**, **WARNING**, and **DANGER** are used in conjunction with the Safety-Alert Symbol (a triangle with an exclamation mark) to indicate the degree of hazard for items of personal safety.



This is the safety alert symbol. It is used to alert you to potential personal injury hazards. Obey all safety messages that follow this symbol to avoid possible injury or death.



Indicates a hazardous situation which, if not avoided, will result in death or serious injury.



Indicates a hazardous situation which, if not avoided, could result in death or serious injury.



Indicates a hazardous situation which, if not avoided, could result in minor or moderate injury.

**IMPORTANT
or NOTICE**

Is used to address practices not related to personal injury.

NOTE

Indicates helpful information.

WOODS®

ALITEC™
BMP®
CENTRAL FABRICATORS®
GANNON®
GILL®
WAIN-ROY®
WOODS®

2 Introduction

CE Construction (Rev. 7/20/2007)

TABLE OF CONTENTS

INTRODUCTION.....	2
GENERAL INFORMATION.....	4
SPECIFICATIONS.....	4
SAFETY RULES.....	5
SAFETY DECALS.....	8
OPERATION.....	10
TROUBLE SHOOTING.....	14
SERVICE.....	16
PARTS LISTS.....	24
FITTING TORQUE CHART.....	35
BOLT TORQUE CHART.....	39
BOLT SIZE CHART.....	40
INDEX.....	41
PRODUCT WARRANTY.....	42
REPLACEMENT PARTS WARRANTY.....	INSIDE BACK COVER



¡LEA EL INSTRUCTIVO!

Si no lee Ingles, pida ayuda a alguien que si lo lea para que le traduzca las medidas de seguridad.



This Operator's Manual should be regarded as part of the machine. Suppliers of both new and second-hand machines must make sure that this manual is provided with the machine.

GENERAL INFORMATION

The purpose of this manual is to assist you in operating and maintaining your planer. Read it carefully. It furnishes information and instructions that will help you achieve years of dependable performance. These instructions have been compiled from extensive field experience and engineering data. Some information may be general in nature due to unknown and varying operating conditions. However, through experience and these instructions, you should be able to develop procedures suitable to your particular situation.

The illustrations and data used in this manual were current at the time of printing but, due to possible inline production changes, your planer may vary slightly in detail. We reserve the right to redesign and change the planer as may be necessary without notification.

Throughout this manual, references are made to right and left direction. These are determined by standing behind the planer facing the direction of forward travel. Blade rotation is counterclockwise as viewed from the top of the planer.

SPECIFICATIONS

CP12FLA

Planing Width12 inches
Planing Depth	0 - 5 inches
Hydraulic Horsepower Required	17 - 28 HP
Number of Carbide Picks	28
Hydraulic Flow Required	15 - 20 gpm
Hydraulic Pressure Required	2000 - 3000 psi
Operating Weight	1200 lbs
Planetary Lubrication	EP90 or Equivalent

SAFETY RULES



ATTENTION! BECOME ALERT! YOUR SAFETY IS INVOLVED!



Safety is a primary concern in the design and manufacture of our products. Unfortunately, our efforts to provide safe equipment can be wiped out by an operator's single careless act.

In addition to the design and configuration of equipment, hazard control and accident prevention are dependent upon the awareness, concern, judgement, and proper training of personnel involved in the operation, transport, maintenance and storage of equipment.

It has been said "The best safety device is an informed, careful operator." We ask you to be that kind of operator.

INSTALLATION

- Hydraulics must be connected as instructed in this manual. Do not substitute parts, modify, or connect in any other way.
- After connecting hoses, check that all control lever positions function as instructed in the Operator's Manual. Do not put into service until control lever and equipment movements are correct.

TRAINING

- Safety instructions are important! Read all attachment and power unit manuals; follow all safety rules and safety decal information. (Replacement manuals and safety decals are available from your dealer. To locate your nearest dealer, check the Dealer Locator at www.WoodsEquipment.com, or in the United States and Canada call 1-800-848-3447.) Failure to follow instructions or safety rules can result in serious injury or death.
- If you do not understand any part of this manual and need assistance, see your dealer.
- Know your controls and how to stop engine and attachment quickly in an emergency.
- Operators must be instructed in and be capable of the safe operation of the equipment, its attachments, and all controls. Do not allow anyone to operate this equipment without proper instructions.
- Keep hands and body away from pressurized lines. Use paper or cardboard, not hands or other body parts to check for leaks. Wear safety goggles. Hydraulic fluid under pressure can easily penetrate skin and will cause serious injury or death.
- Make sure that all operating and service personnel know that if hydraulic fluid penetrates skin, it

must be surgically removed as soon as possible by a doctor familiar with this form of injury or gangrene, serious injury, or death will result. **CONTACT A PHYSICIAN IMMEDIATELY IF FLUID ENTERS SKIN OR EYES. DO NOT DELAY.**

- Never allow children or untrained persons to operate equipment.

PREPARATION

- Check that all hardware is properly installed. Always tighten to torque chart specifications unless instructed otherwise in this manual.
- Counterweight ballast may be required for machine stability. Check your power unit manual or contact your dealer.
- Air in hydraulic systems can cause erratic operation and allows loads or equipment components to drop unexpectedly. When connecting equipment or hoses or performing any hydraulic maintenance, purge any air in hydraulic system by operating all hydraulic functions several times. Do this before putting into service or allowing anyone to approach the equipment.
- After connecting hoses, check that all control lever positions function as instructed in the Operator's Manual. Do not put into service until control lever and equipment movements are correct.
- Protective hose sleeves must cover all hydraulic hoses within 20 inches of the operator and be secured onto metal hose fittings. Replace hoses or sleeves if damaged or if protective sleeve cannot be properly positioned or secured.
- Make sure all hydraulic hoses, fittings, and valves are in good condition and not leaking before starting power unit or using equipment. Check and route hoses carefully to prevent damage. Hoses must not be twisted, bent sharply, kinked, frayed, pinched, or come into contact with any moving parts. Operate moveable components through full operational range to check clearances. Replace any damaged hoses immediately.
- Your dealer can supply original equipment hydraulic accessories and repair parts. Substitute parts may not meet original equipment specifications and may be dangerous.
- Always wear relatively tight and belted clothing to avoid getting caught in moving parts. Wear sturdy, rough-soled work shoes and protective equipment for eyes, hair, hands, hearing, and head; and respirator or filter mask where appropriate.

SAFETY RULES



ATTENTION! BECOME ALERT! YOUR SAFETY IS INVOLVED!



■ Be sure attachment is properly secured, adjusted, and in good operating condition. Coupler lockpins must be fully extended and properly engaged into attachment retaining slots.

■ Power unit must be equipped with ROPS and seat belt/operator restraint. Keep seat belt/operator restraint securely fastened/engaged. Falling off power unit can result in death from being run over or crushed. Keep ROPS systems in place at all times.

■ Make sure all safety decals are installed. Replace if damaged. (See Safety Decals section for location.)

■ Make sure shields and guards are properly installed and in good condition. Replace if damaged.

■ Inspect and clear area of stones, branches, or other hard objects that might be thrown, causing injury or damage.

OPERATION

■ Improper operation can cause the machine to tip or roll over and cause injury or death.

- Keep power unit lift arms and attachment as low as possible.
- Do not travel or turn with power unit lift arms and attachment raised.
- Turn only on level ground.
- Go up and down slopes, not across them.
- Keep the heavy end of the machine uphill.
- Do not overload the machine.

■ Never use attachment to carry loads that exceed the rated operating capacity or other specifications of the power unit. Check your power unit manual or see your dealer for rated operating capacity. Exceeding this capacity can cause machine to tip, roll over, or present other hazards that can cause injury or death.

■ Do not allow bystanders in the area when operating, attaching, removing, assembling, or servicing equipment.

■ Contact with high voltage, overhead power lines, underground cables, gas lines, and other hazards can cause serious injury or death from electrocution, explosion, or fire.

■ Keep bystanders away from equipment.

■ Never direct discharge toward people, animals, or property.

■ Do not operate or transport equipment while under the influence of alcohol or drugs.

■ Operate only in daylight or good artificial light.

■ Keep hands, feet, hair, and clothing away from equipment while engine is running. Stay clear of all moving parts.

■ Always comply with all state and local lighting and marking requirements.

■ Do not allow riders. Do not lift or carry anybody on the power unit or attachments.

■ Always sit in power unit seat when operating controls or starting engine. Securely fasten seat belt/operator restraint, place transmission in park or neutral, engage brake and ensure all other controls are disengaged before starting power unit engine.

■ Look down and to the rear and make sure area is clear before operating in reverse.

■ Use extreme care when working close to fences, ditches, other obstructions, or on hillsides.

■ Do not operate or transport on steep slopes.

■ Do not stop, start, or change directions suddenly on slopes.

■ Use extreme care and reduce ground speed on slopes and rough terrain.

■ Watch for hidden hazards on the terrain during operation.

■ Stop power unit and implement immediately upon striking an obstruction. Dismount power unit, using proper procedure. Inspect and repair any damage before resuming operation.

■ Leak down or failure of mechanical or hydraulic system can cause equipment to drop.

■ Before making any adjustments on attachment, stop engine and engage parking brake. Never adjust or work on attachment while the power unit or attachment is running.

■ Before leaving operator's seat, lower lift arms and put attachment on the ground. Engage brake, stop engine, remove key, and remove seat belt.

MAINTENANCE

■ Before leaving operator's seat, lower lift arms and put attachment on the ground. Engage brake, stop engine, remove key, and remove seat belt.

■ **NEVER GO UNDERNEATH EQUIPMENT.** Never place any part of the body underneath equipment



SAFETY RULES

ATTENTION! BECOME ALERT! YOUR SAFETY IS INVOLVED!



or between moveable parts even when the engine has been turned off. Hydraulic system leak-down, hydraulic system failures, mechanical failures, or movement of control levers can cause equipment to drop or rotate unexpectedly and cause severe injury or death.

- Service work does not require going underneath.
- Read Operator's Manual for service instructions or have service performed by a qualified dealer.
- Do not modify or alter or permit anyone else to modify or alter the equipment or any of its components in any way.
- Your dealer can supply original equipment hydraulic accessories and repair parts. Substitute parts may not meet original equipment specifications and may be dangerous.
- When removing front wheel pins, be sure to support the front of the depth skid to prevent hands or feet from being crushed.
- Always wear relatively tight and belted clothing to avoid getting caught in moving parts. Wear sturdy, rough-soled work shoes and protective equipment for eyes, hair, hands, hearing, and head; and respirator or filter mask where appropriate.
- Do not allow bystanders in the area when operating, attaching, removing, assembling, or servicing equipment.
- Be sure attachment is properly secured, adjusted, and in good operating condition. Coupler lockpins must be fully extended and properly engaged into attachment retaining slots.

- Never perform service or maintenance with engine running.
- Keep all persons away from operator control area while performing adjustments, service, or maintenance.
- Tighten all bolts, nuts, and screws to torque chart specifications. Check that all cotter pins are installed securely to ensure equipment is in a safe condition before putting unit into service.
- Make sure all safety decals are installed. Replace if damaged. (See Safety Decals section for location.)
- Make sure shields and guards are properly installed and in good condition. Replace if damaged.
- Do not disconnect hydraulic lines until all system pressure is relieved. Lower unit to ground, stop engine, and operate all hydraulic control levers.
- Leak down or failure of mechanical or hydraulic system can cause equipment to drop.

STORAGE

- Follow manual instructions for storage.
- Keep children and bystanders away from storage area.





SAFETY & INSTRUCTIONAL DECALS

ATTENTION! BECOME ALERT! YOUR SAFETY IS INVOLVED!

Replace Immediately If Damaged!



8 - SERIAL NUMBER PLATE



5 - D0193



10 - D0404



12 - 19924

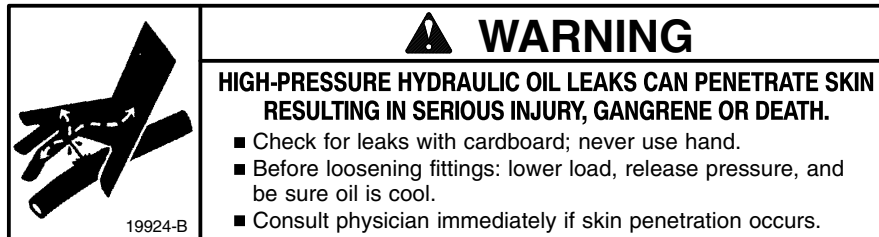

4 - D0192



6 - D0195

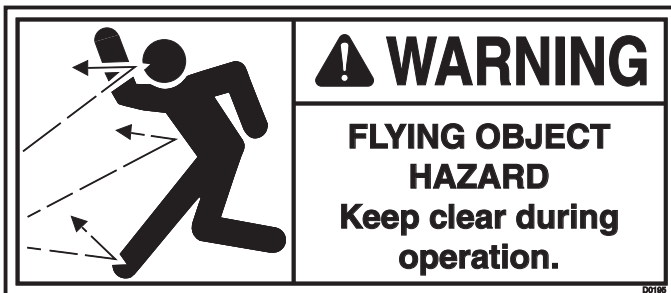

(Safety Decals continued on next page)



SAFETY & INSTRUCTIONAL DECALS

ATTENTION! BECOME ALERT! YOUR SAFETY IS INVOLVED!
Replace Immediately If Damaged!



(Safety Decals continued from previous page)

7 - D0209

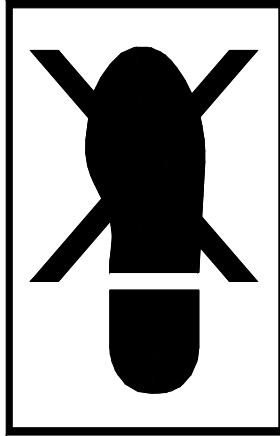

13 - 54519

 WARNING	
	
<p>FALLING OFF CAN RESULT IN BEING RUN OVER.</p> <ul style="list-style-type: none"> ■ Skid steer must have ROPS and seat belt/operator restraint. Keep seat belt/operator restraint securely fastened. ■ Allow no riders. 	
<p>RAISED EQUIPMENT CAN DROP AND CRUSH.</p> <ul style="list-style-type: none"> ■ Never go underneath raised equipment or raised Skid Steer lift arms, which can drop from hydraulic leak down, hydraulic system failures, movement of control levers or mechanical linkage failures. ■ Service work does not require going underneath equipment. Read manual instructions. 	
<p>FALLING OFF OR GOING UNDERNEATH EQUIPMENT CAN RESULT IN SERIOUS INJURY OR DEATH.</p>	
<small>54519-A</small>	

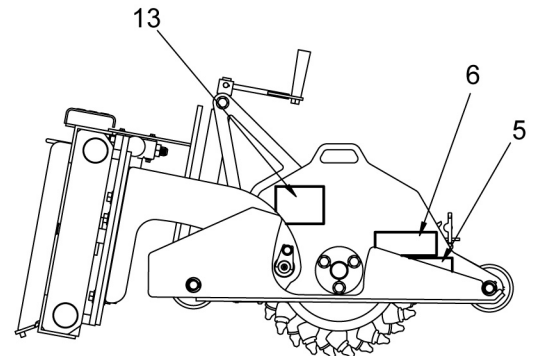
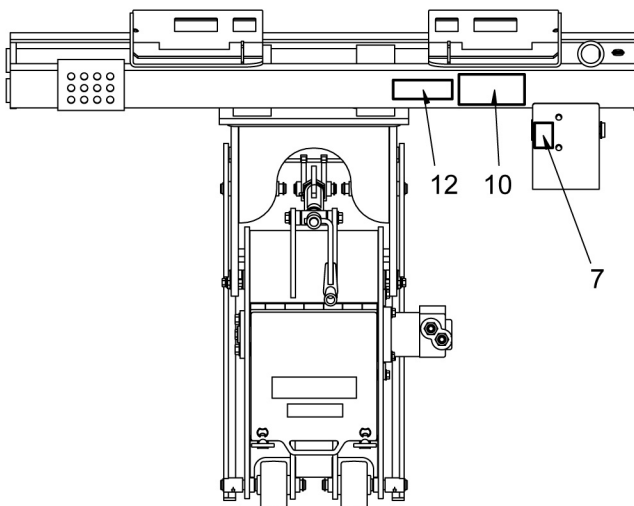
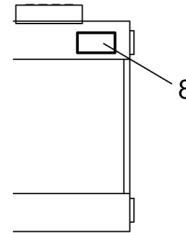
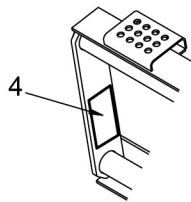

LA1

OPERATION

WARNING

■ Safety instructions are important! Read all attachment and power unit manuals; follow all safety rules and safety decal information. (Replacement manuals and safety decals are available from your dealer.) Failure to follow instructions or safety rules can result in serious injury or death.

■ Power unit must be equipped with ROPS and seat belt/operator restraint. Keep seat belt/operator restraint securely fastened/engaged. Falling off power unit can result in death from being run over or crushed. Keep ROPS systems in place at all times.

■ Operators must be instructed in and be capable of the safe operation of the equipment, its attachments, and all controls. Do not allow anyone to operate this equipment without proper instructions.

NOTICE

■ Skid steers must be equipped with an auxiliary hydraulic system capable of supplying continuous flow for hydraulic motor operation.

PRE-OPERATION CHECK LIST

(OWNER'S RESPONSIBILITY)

- ___ Review and follow all safety rules and safety decal instructions on page 5 through page 9.
- ___ Check that all safety decals are installed and in good condition. Replace if damaged.
- ___ Check that all shields and guards are properly installed and in good condition. Replace if damaged.
- ___ Check that equipment is properly and securely attached to skid steer.
- ___ Check that all hardware and cotter pins are properly installed and secured.
- ___ Do not allow riders. Keep all bystanders away from equipment working area.
- ___ Check all lubrication points and grease as instructed. See "Lubrication" on page 22.
- ___ Check that all hydraulic hoses and fittings are in good condition and not leaking before starting skid steer.
- ___ Check that hoses are not twisted, bent sharply, kinked, frayed or pulled tight. Replace any damaged hoses immediately.

___ Make sure skid steer ROPS and seat belt are in good condition. Keep seat belt securely fastened during operation.

ATTACHING PLANER

1. Place the coupler pins in the disengaged position as shown in Figure 1.
2. Rotate the skid steer attach slightly forward.



Figure 1.

3. Fully lower the lift arms (2) as shown in Figure 1.
4. Pull forward to the planer. Make sure the outside of the skid steer attach (1) is aligned with the inside of the planer attach (2).
5. Continue to pull forward until the skid steer attach makes contact with the planer attach.
6. Raise the skid steer arms until the top of the skid steer attach contacts the top latch bar (3) on the attachment.

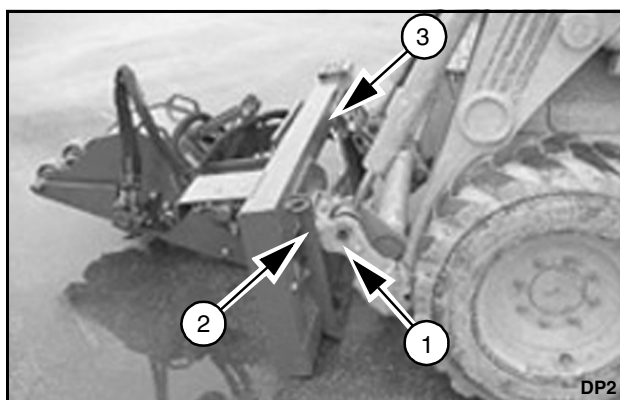

Figure 2.

7. Roll the skid steer arms back until the planer is completely off the ground as shown in Figure 3.
8. Engage the parking brake on the skid steer.
9. Stop the engine.



Figure 3.

10. Relieve the back pressure in the auxiliary hydraulic system.
11. Move the coupler pins to the engaged position.
12. Hook up the auxiliary hydraulic hoses. Make sure the hoses are routed to prevent hose interference as shown in Figure 4.



Figure 4.

ADJUST PLANING DEPTH

1. Raise the planer 6" to 8" off the ground as shown in Figure 5.

2. Engage the parking brake on the skid steer.
3. Stop the engine.



Figure 5.

4. Adjust the depth jack located at back of the planer, clockwise for increased depth or counterclockwise for lesser depth. To check the depth, use the pointer rod (1) location on the depth decal (2) as shown in Figure 6.

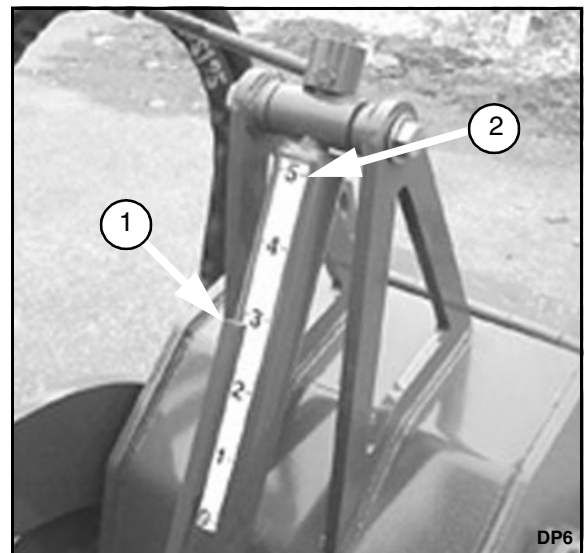

Figure 6.

ADJUST HEAD ANGLE

1. If an angle cut is desired, the planer can be tilted $\pm 15^\circ$. Loosen the three 5/8" backplate bolts as shown in Figure 7.



Figure 7.

2. Rotate the planer to the desired position (see Figure 8). Tighten the backplate bolts.

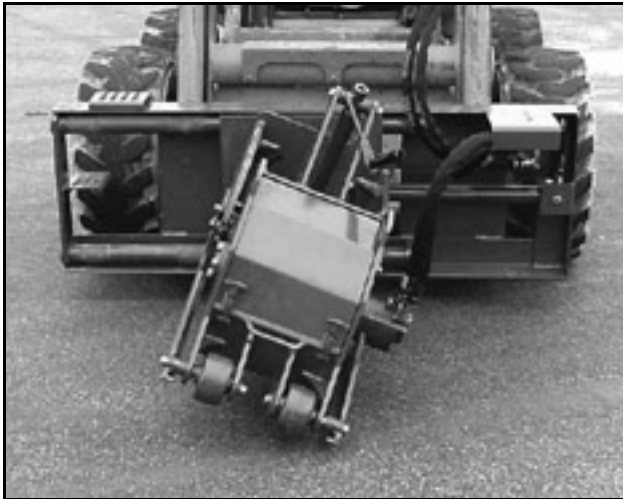

Figure 8.

SIDESHIFT ADJUSTMENT

1. Raise the planer 6 to 8" off the ground.
2. Engage the parking brake on the skid steer.
3. Stop the engine.
4. The planer can be shifted side-to-side using the sideshift function. To operate the sideshift cylinder pull the knob on the diverter valve outward as shown in Figure 9.

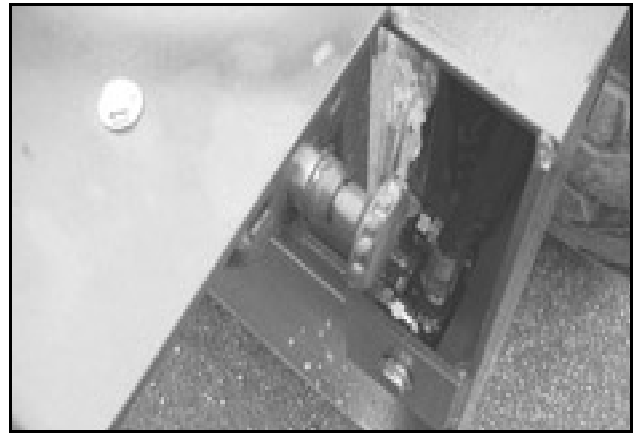

Figure 9.

5. Enter the skid steer and start the engine.
6. Activate the auxiliary hydraulics to move the planer to the desired position.
7. Stop the engine and engage the parking brake. Exit the skid steer.
8. Shift the diverter valve back to the planing position by pushing the knob inward as shown in Figure 10.

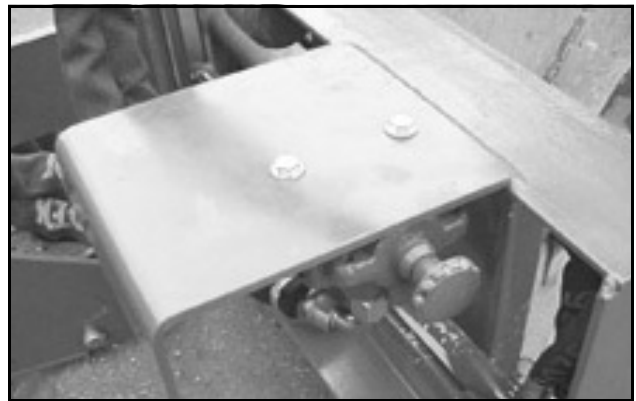

Figure 10.

PLANER OPERATION

1. Adjust the planer to the desired cutting depth, cutting angle and planer position.
2. Roll the skid steer arms back and lower completely.
3. Engage the auxiliary hydraulics. Make sure the drum is rotating in a counter-clockwise position if viewed from the right side of the planer.
4. Bring the skid steer to high idle.
5. Slowly roll the skid steer arms forward to engage the planer. (If the planer stalls, roll the skid steer arms back until the planer drum begins rotating.)
6. Continue to rotate the skid steer arms forward until the front and rear wheels of the planer are on the ground and the front wheels of the skid steer are off the ground as shown in Figure 11.



Figure 11.

7. To avoid excessive vibration and to achieve the best cutting results, the planer stop should be in the float position during the cutting operation as shown in Figure 12.

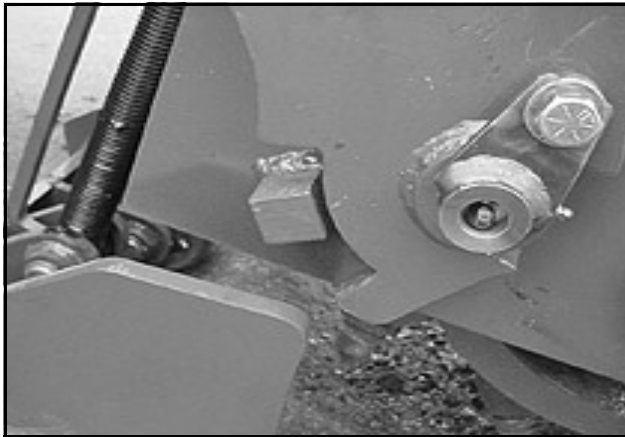

Figure 12.

8. Move the skid steer forward, maintaining a constant speed. If the drum stalls, stop forward movement. You may be required to reverse the direction of the skid steer momentarily to allow the drum to begin rotating again.
9. When the end of the cut is reached, stop forward movement, idle back the skid steer and disengage the auxiliary hydraulics.
10. Roll back the skid steer arms until the planer and drum clear the cut.
11. Repeat Steps 1 through 10 as necessary.

TRANSPORTING

Roll the skid steer arms fully back and raise the planer 12 to 15" off the ground. Avoid excessive ground speed and sudden maneuvers.

NOTICE

- When transporting attachment make sure the drum does not contact ground as this may cause the drum to turn resulting in damage to the motor.

CLEANING

After Each Use

- Remove large debris such as clumps of dirt, grass, crop residue, etc. from machine.
- Inspect machine and replace worn or damaged parts.
- Replace any safety decals that are missing or not readable.

Periodically or Before Extended Storage

- Clean large debris such as clumps of dirt, grass, crop residue, etc. from machine.
- Remove the remainder using a low-pressure water spray.
 1. Be careful when spraying near scratched or torn safety decals or near edges of decals as water spray can peel decal off surface.
 2. Be careful when spraying near chipped or scratched paint as water spray can lift paint.
 3. If a pressure washer is used, follow the advice of the pressure washer manufacturer.
- Inspect machine and replace worn or damaged parts.
- Sand down scratches and the edges of areas of missing paint and coat with Woods spray paint of matching color (purchase from your Woods dealer).
- Replace any safety decals that are missing or not readable (supplied free by your Woods dealer). See Safety Decals section for location drawing.

TROUBLESHOOTING

PROBLEM	POSSIBLE CAUSES	CHECK THE FOLLOWING
Motor on the planer will not operate	<p>Auxiliary hoses are not hooked up to the skid steer</p> <p>The diverter valve is in the sideshift position</p> <p>There is an obstruction in one or both of the auxiliary hoses</p> <p>One or more seals on the motor have failed</p> <p>The skid steer auxiliary hydraulics are not operating properly</p>	<p>Inspect the connections visually (make sure the quick couplers are fully engaged).</p> <p>Make sure the diverter valve knob is pushed all the way in.</p> <p>Remove and inspect the hoses visually.</p> <p>Contact your dealer.</p> <p>Refer to the skid steer owner's manual.</p>
Drum rotates sluggishly	<p>The diverter valve is not fully shifted to the planer position</p> <p>Insufficient hydraulic flow from the skid steer</p> <p>The hydraulic oil filter on the skid steer is dirty</p> <p>One or more seals on the motor have failed</p>	<p>Make sure diverter valve knob is pushed all the way in.</p> <p>Refer to the skid steer owner's manual.</p> <p>Refer to the skid steer owner's manual.</p> <p>Contact your dealer.</p>
Motor operates, but the drum does not rotate	<p>Key on the motor is sheared</p>	<p>Inspect visually and replace as required.</p>
Oil is leaking from the motor area	<p>One or more seals on the motor have failed</p> <p>O-rings on fittings are damaged</p> <p>Fittings are loose or damaged</p> <p>Hydraulic hoses are loose or damaged</p>	<p>Contact your dealer.</p> <p>Visually inspect O-rings and replace as needed.</p> <p>Replace or tighten as required.</p> <p>Replace or tighten as required.</p>
Insufficient cutting power	<p>One or more seals on the motor have failed</p> <p>Oil filter on the skid steer is dirty</p> <p>Insufficient auxiliary flow from the skid steer</p> <p>Relief valve on the skid steer is not set properly</p>	<p>Contact your dealer.</p> <p>Refer to the skid steer owner's manual.</p> <p>Refer to the skid steer owner's manual.</p> <p>Refer to the skid steer owner's manual.</p>
Excessive oil temperature	<p>Obstruction in one or both auxiliary hydraulic hoses</p> <p>Hydraulic oil level on the skid steer is low</p> <p>Hydraulic oil in the skid steer is dirty</p> <p>Hydraulic oil filter on the skid steer is dirty</p> <p>Relief valve on the skid steer is not set properly</p>	<p>Remove and visually inspect and replace the hoses as necessary.</p> <p>Refer to the skid steer owner's manual.</p> <p>Refer to the skid steer owner's manual.</p> <p>Refer to the skid steer owner's manual.</p> <p>Refer to the skid steer owner's manual.</p>

PROBLEM	POSSIBLE CAUSES	CHECK THE FOLLOWING
Drum rotates in the wrong direction	<p>Auxiliary hydraulics are being activated in the wrong direction</p> <p>Quick disconnects are switched on the auxiliary hoses</p>	<p>Reverse direction of the auxiliary flow.</p> <p>Switch male and female auxiliary quick couplers.</p>
Hydraulic sideshift is not operating	<p>Diverter valve is set in the planer position</p> <p>Hoses to the sideshift cylinder are obstructed</p> <p>One or more seals in the sideshift cylinder have failed</p> <p>Backplate is bound on the sideshift frame</p> <p>Insufficient hydraulic flow from the skid steer</p> <p>Air is trapped in the sideshift cylinder hoses</p> <p>Cylinder rod is bent</p>	<p>Make sure the diverter valve knob is pulled all the way out.</p> <p>Remove and visually inspect and replace the hoses as necessary.</p> <p>Contact your dealer.</p> <p>Remove rod end of the cylinder from the backplate and verify that the cylinder is operating properly (refer to service section).</p> <p>Refer to the skid steer owner's manual.</p> <p>Take the hoses loose from the cylinder, activate the sideshift function to evacuate air and reinstall hoses.</p> <p>Visually inspect the cylinder for damage.</p>
Oil leaking from the sideshift cylinder	<p>One or more seals on the cylinder have failed</p> <p>O-rings on the fittings are damaged</p> <p>Fittings loose or damaged</p> <p>Hydraulic hoses are loose or damaged</p>	<p>Contact your dealer.</p> <p>Visually inspect O-rings, replace as required.</p> <p>Replace or tighten as required.</p> <p>Replace or tighten as required.</p>
Excessive vibration during planing operation	<p>Picks are excessively worn</p> <p>Insufficient down force due to incorrect operating procedure</p> <p>Pivot pins excessively worn</p>	<p>Visually inspect the picks. Replace as necessary.</p> <p>Make sure the chassis stops are in the float position during operation. (Refer to "Operation" Figure 12 on page 13.)</p> <p>Remove the pins and inspect for wear.</p>

SERVICE

SIDESHIFT CYLINDER REMOVAL

1. Remove both hoses (1) from the cylinder as shown in Figure 13.

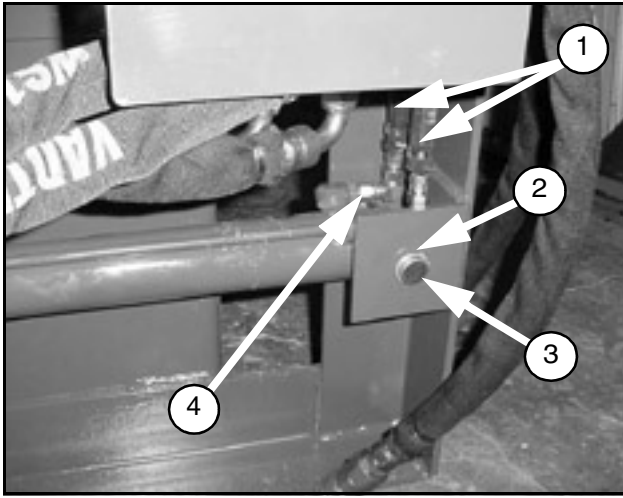

Figure 13.

2. Remove the snap rings (2) and (3).
3. Remove the sideshift cylinder pin (4).
4. Slide the rod end of cylinder from the backplate pin (5) as shown in Figure 14.

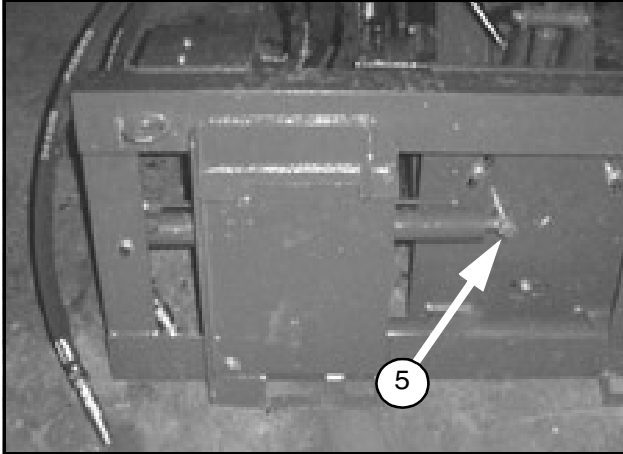

Figure 14.

SIDESHIFT CYLINDER INSTALLATION

1. Install the rod end of the cylinder on the backplate pin (5) as shown in Figure 14.

2. Insert the sideshift cylinder pin (4) as shown in Figure 13.
3. Install the snap rings (2) and (3).
4. Assemble the hoses (1).
5. Torque the two hose fittings to 19 lbs-ft. (26 N-m).

DRUM REMOVAL

1. Remove and cap the motor hoses.
2. Support the chassis with a hoist so the drum just touches the ground as shown in Figure 15.
3. Remove the inner snap rings (1) from the front wheel pins.
4. Slide out the front wheel pins (2).

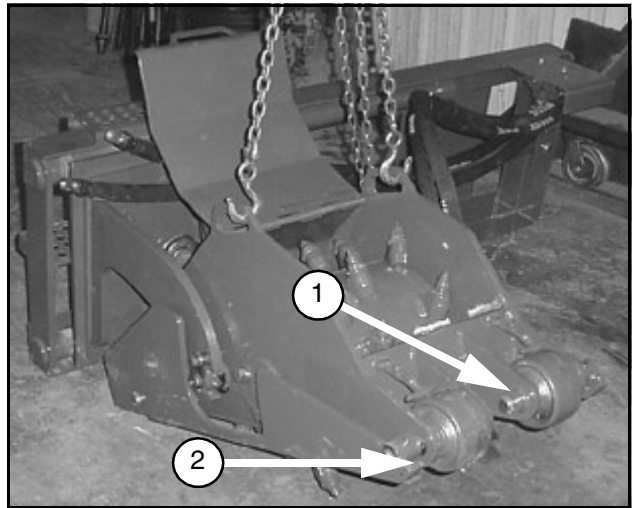

Figure 15.

⚠ CAUTION

- When removing the front wheel pins, be sure to support the front of the depth skid to prevent hands or feet from being crushed upon pin removal.

5. Remove the snap ring from one side of the lower depth jack pin (3) and slide the lower depth jack pin outward until the jack is free as shown in Figure 16. (The pin cannot be removed completely with the rear wheels installed.)

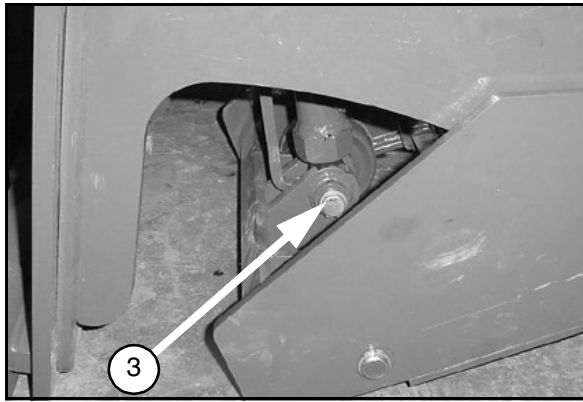

Figure 16.

6. Lift the planer chassis to allow sufficient clearance to slide out the depth skid as shown in Figure 17.
7. Remove the depth skid.

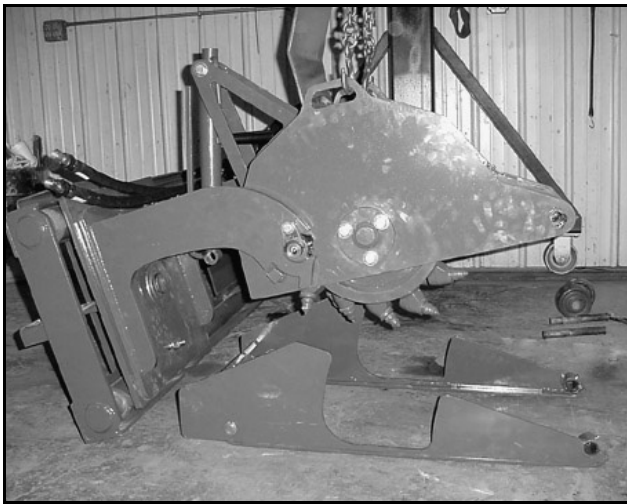

Figure 17.

8. Lower the chassis until the drum just touches the ground as shown in Figure 18.
9. Remove the three dead shaft bolts (5).

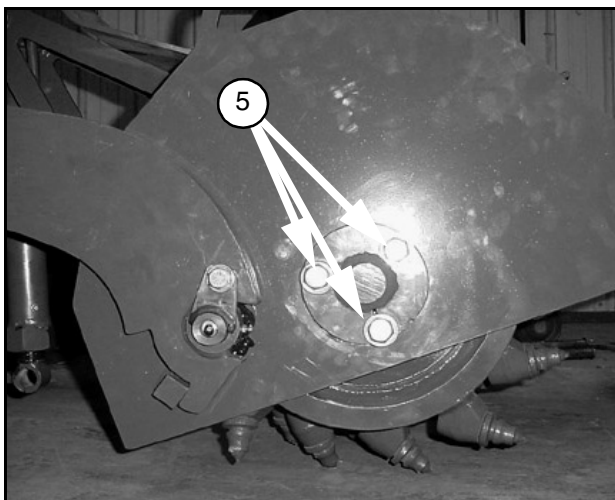

Figure 18.

10. Remove the two upper motor bolts (7) and the two motor plate mount bolts (6) as shown in Figure 19.

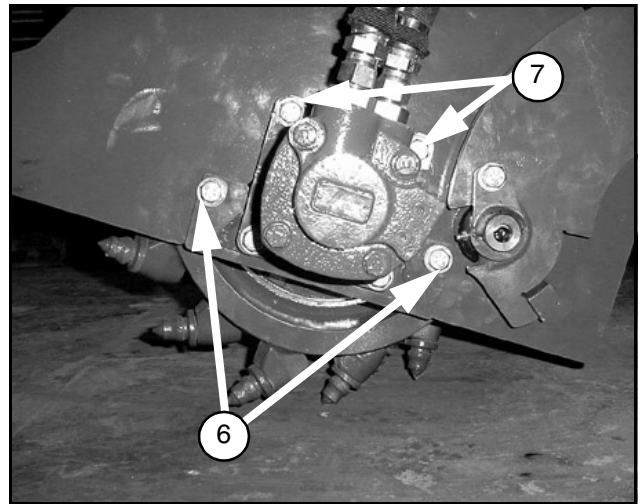

Figure 19.

11. Slide out the dead shaft (8) as shown in Figure 20.
12. Raise the planer chassis to provide sufficient room to slide the drum/drive assembly out.

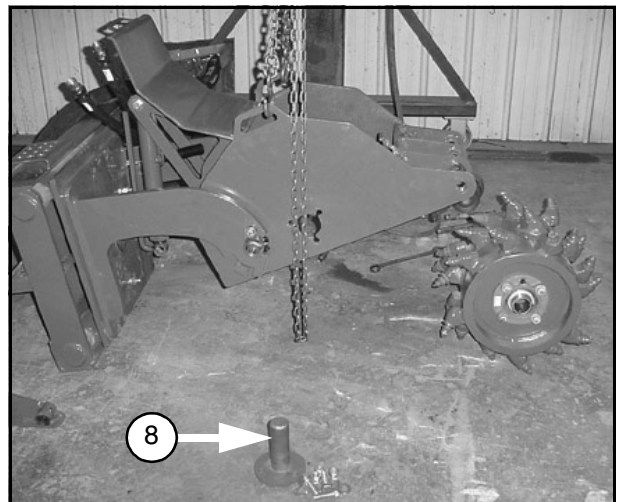

Figure 20.

13. Turn the drum onto its side with the bearing side down, as shown in Figure 21.
14. Remove 6 nuts (9) that secure the hub to the drum. The studs may back out of the drum when attempting to remove these nuts. This is common and will not effect the operation of the planer upon reassembly.

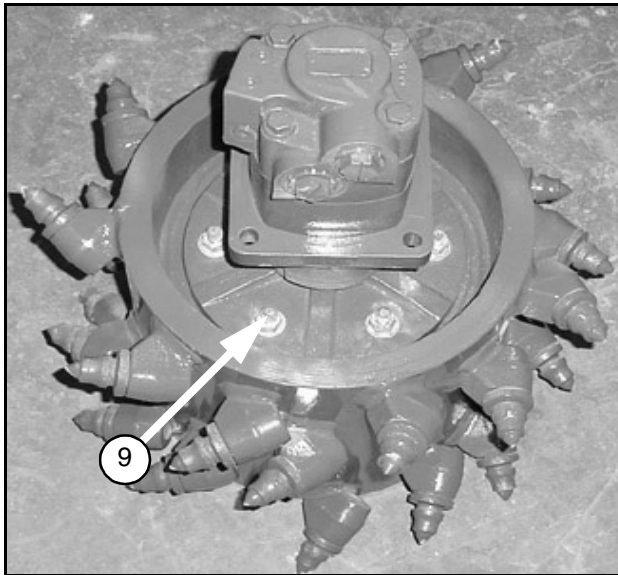

Figure 21.

15. Turn the drum over to its other side, as shown in Figure 22.
16. Remove the 4 nuts (10) that secure bearing to the drum. The studs may back out of the drum when attempting to remove these nuts. This is common and will not effect the operation of the planer upon reassembly.

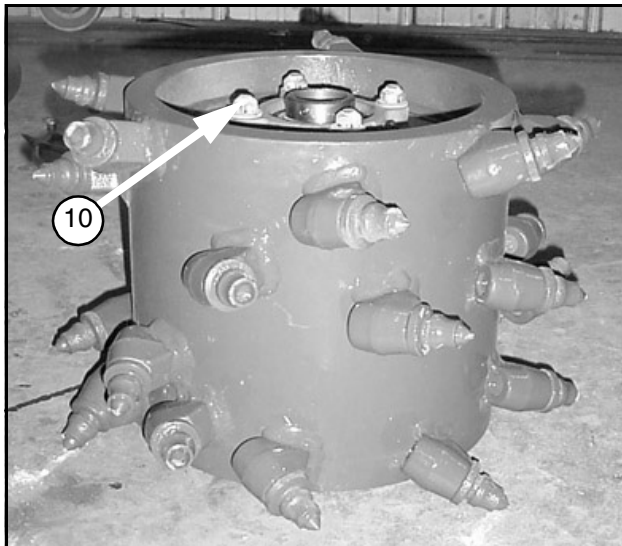

Figure 22.

DRUM INSTALLATION

1. Install the bearing (1) to the drum (2) and torque four 1/2" – 20 nuts (3) to 90 lbs-ft. (122 N-m) as shown in Figure 23.

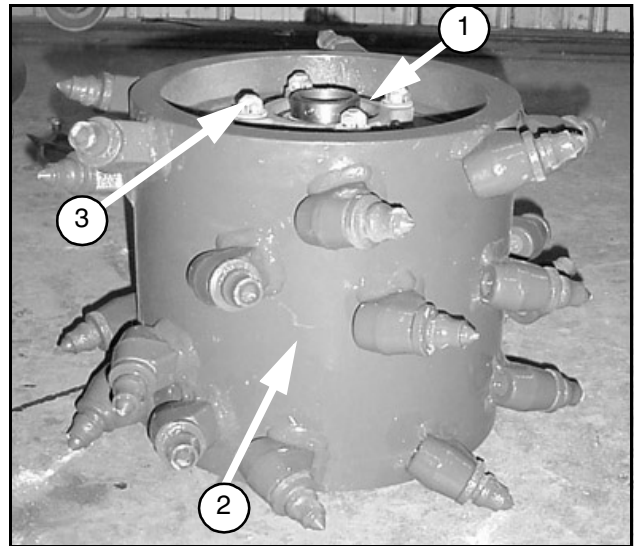

Figure 23.

2. On the opposite side of the drum as shown in Figure 24 install the motor/hub assembly (4) to the drum and torque the six 1/2" – 20 nuts (5) to 90 lbs-ft. (122 N-m).

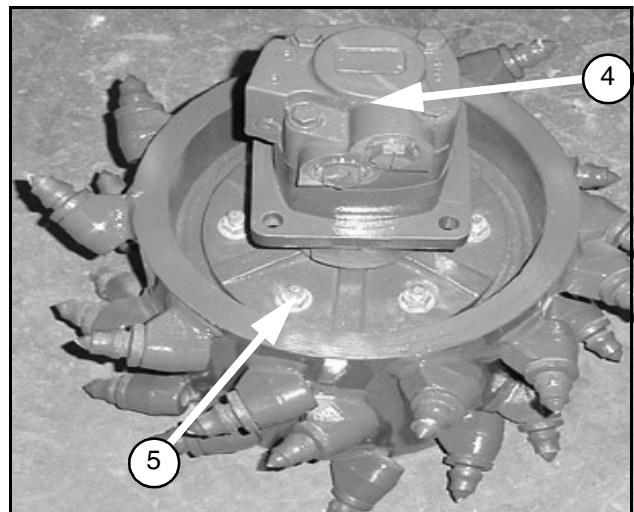

Figure 24.

3. Slide the drum under the chassis and lower the chassis until the motor pilots against the sideplate as shown in Figure 25.

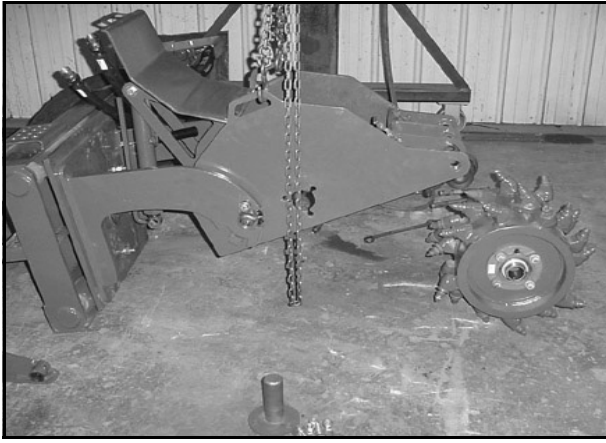

Figure 25.

4. Apply a coat of anti-seize grease to a portion of the dead shaft (6) that is inserted into the bearing as shown in Figure 26.

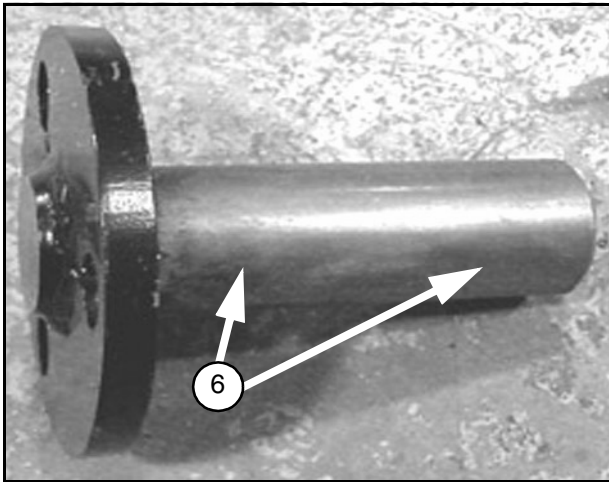

Figure 26.

5. Insert the dead shaft through the chassis sideplate into the drum bearing as shown in Figure 27.
6. Install three 5/8" –11 bolts (7), six 5/8" washers (8) and three 5/8" –11 nuts (9) through the dead shaft and into the chassis sideplate. Do not tighten.

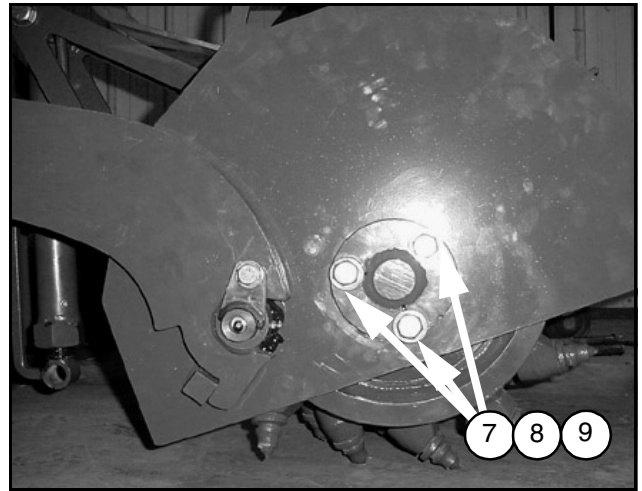

Figure 27.

7. Install two 1/2" x 1-1/2" – 13 bolts (10), four 1/2" washers (11), and two 1/2" – 13 (12) nuts through the motor mount plate into the chassis as shown in Figure 28. Do not tighten.

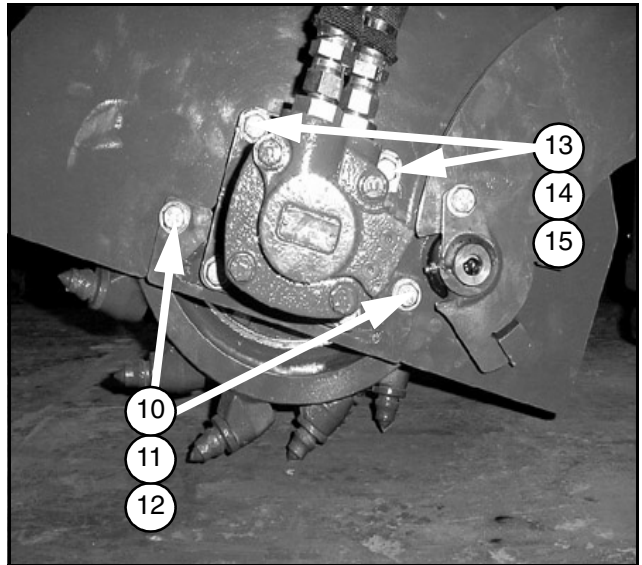

Figure 28.

8. Install two 1/2" x 2 – 13 bolts (13), four 1/2" washers (14), and two 1/2" – 13 (15) nuts through the motor into the chassis and torque to 110 lbs-ft. (149 N-m) as shown in Figure 28.
9. Torque the motor mount plate bolts (10) to 110 lbs-ft. (149 N-m).
10. Torque the dead-shaft bolts (7) as shown in Figure 27 to 220 lbs-ft.
11. Raise the chassis to provide sufficient clearance. Slide the depth skid under the chassis as shown in Figure 29.

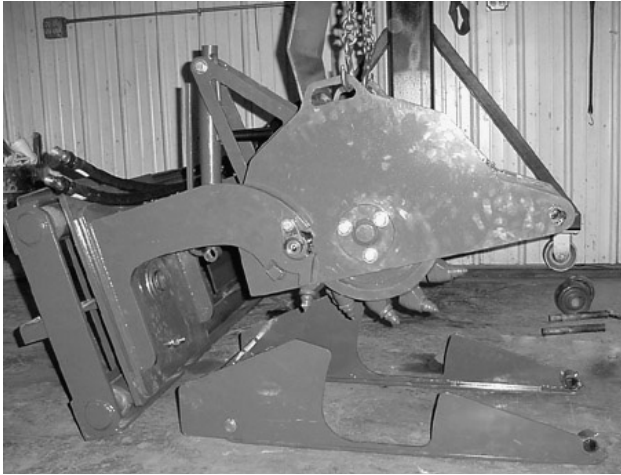

Figure 29.

12. Install the lower depth jack pin (16) and the snap ring (17) as shown in Figure 30.

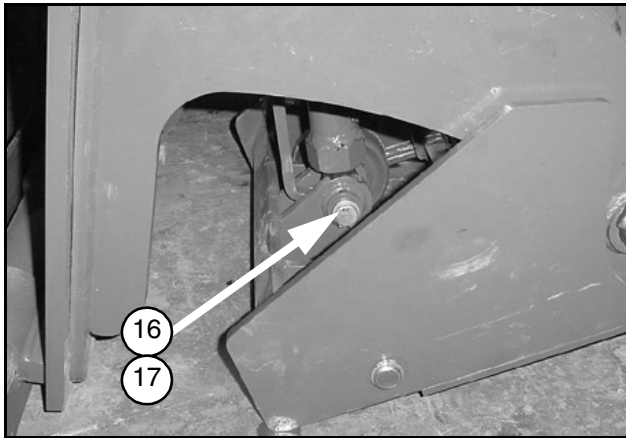

Figure 30.

13. Install the front wheel pins (18) and the snap rings (19) as shown in Figure 31.

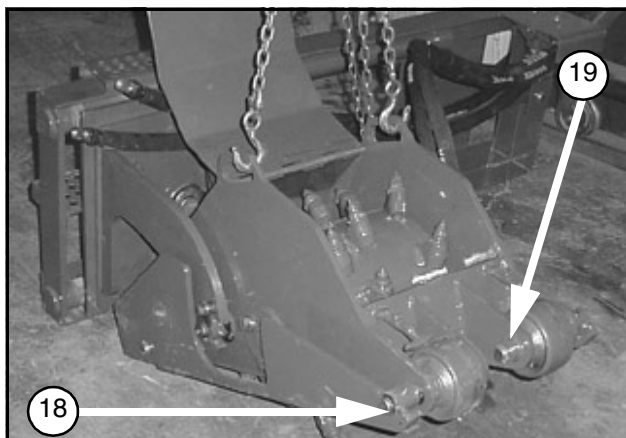

Figure 31.

MOTOR REMOVAL

1. Perform Steps 1 through 11 of Drum Removal instructions. (See "Drum Removal" on page 16.)

2. Remove the motor mount plate (1) as shown in Figure 32.

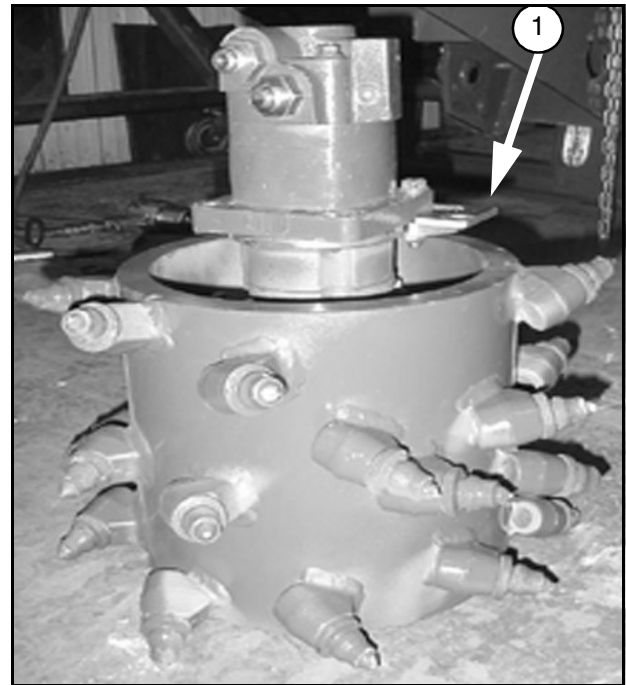

Figure 32.

3. Place the motor/hub assembly into a vice as shown in Figure 33.

4. Remove the cotter pin (2) and the motor nut (3).

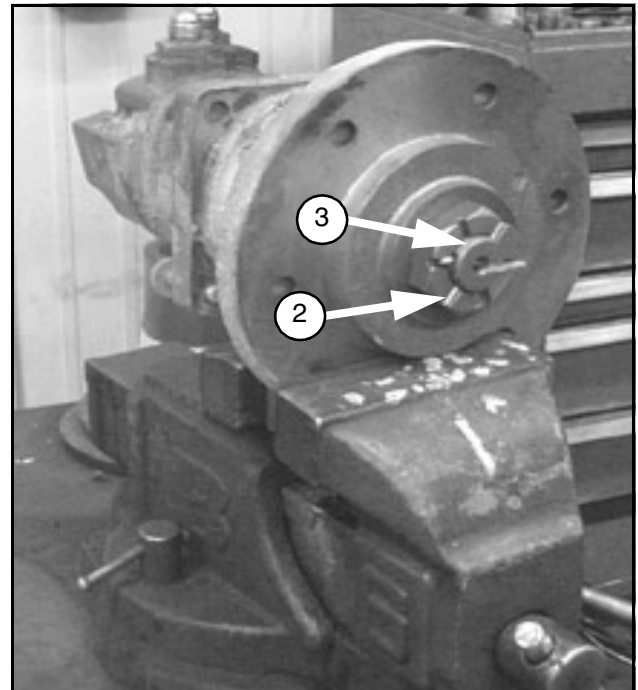

Figure 33.

5. Use a gear puller to remove the hub from the motor as shown in Figure 34.

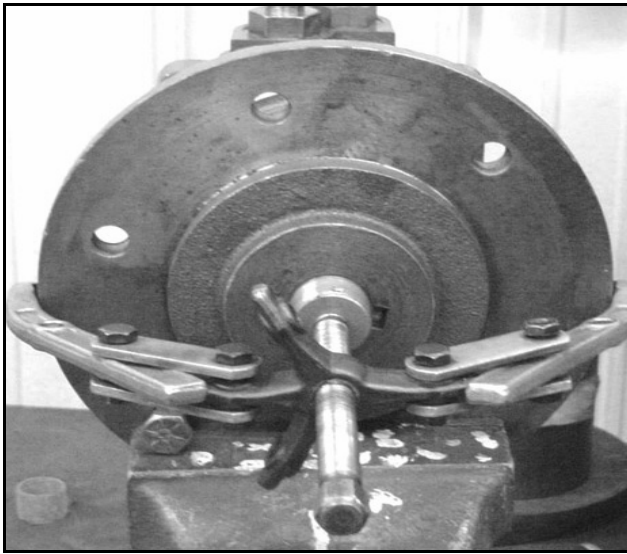

Figure 34.

MOTOR INSTALLATION

1. Place the key (1) into the keyway on the motor shaft as shown in Figure 35.
2. Apply a coat of anti-seize grease to the motor shaft.

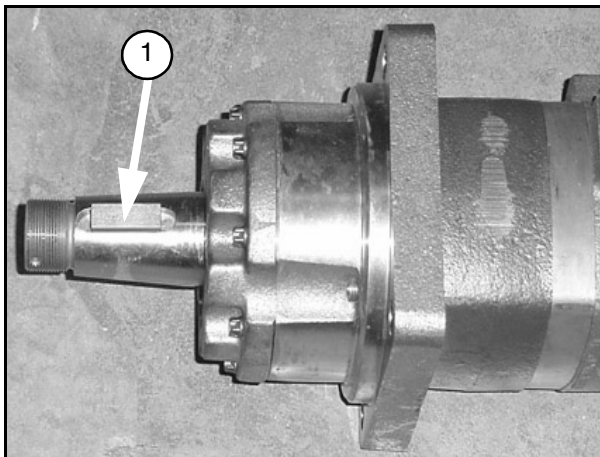

Figure 35.

3. Align the keyway in the hub with the key on the motor shaft.
4. Slide the hub onto the shaft and install a motor nut finger tight.
5. Place the hub/motor assembly into a vice.
6. Torque the motor nut to 275 lbs-ft. (373 N-m).
7. Back the nut off until the slot on the nut aligns with the cotter pin hole on the motor shaft. Install the cotter pin.
8. Perform Steps 2 through 13 of Drum Installation instructions. (See "Drum Installation" on page 18.)

PIVOT PIN REMOVAL

1. Remove the flag pin bolt (1) as shown in Figure 36.
2. Remove the pivot pin (2).

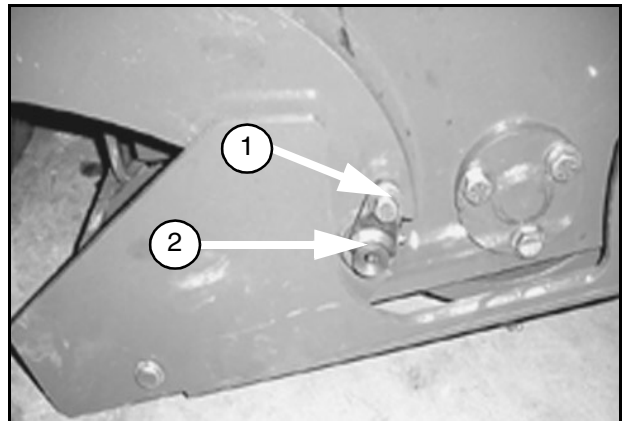

Figure 36.

BEARING REMOVAL

Perform Steps 1 through 12 (See "Drum Removal" on page 16.) omitting Step 11.

BEARING INSTALLATION

Perform steps 1 through 13 (See "Drum Installation" on page 18.) omitting Step 2.

PIVOT PIN INSTALLATION

1. Install the pivot pin through the pivot arm into the chassis as shown in Figure 37.
2. Assemble one 1/2" x 1-3/4" – 11 bolt (1), one 1/2" flat washer (2), and one 1/2" lock washer (3) and torque to 110 lbs-ft. (149 N-m).
3. Grease the flag pin.

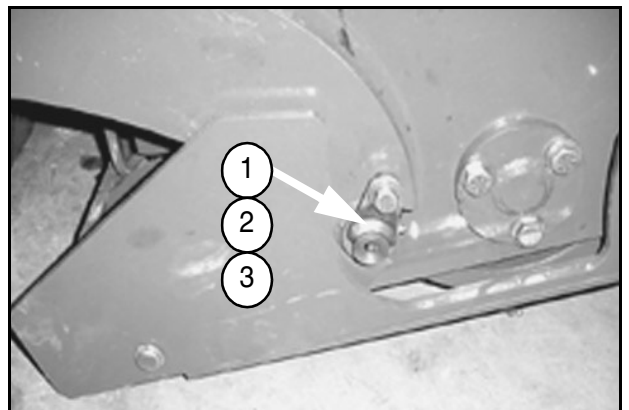

Figure 37.

PICK REMOVAL

WARNING

■ Always wear relatively tight and belted clothing to avoid entanglement in moving parts. Wear sturdy, rough-soled work shoes and protective equipment for eyes, hair, hands, hearing, and head.

1. Insert the pick removal tool (1) into the slot on the pick.
2. Hit the pick removal tool on the round protrusion to drive the pick out.

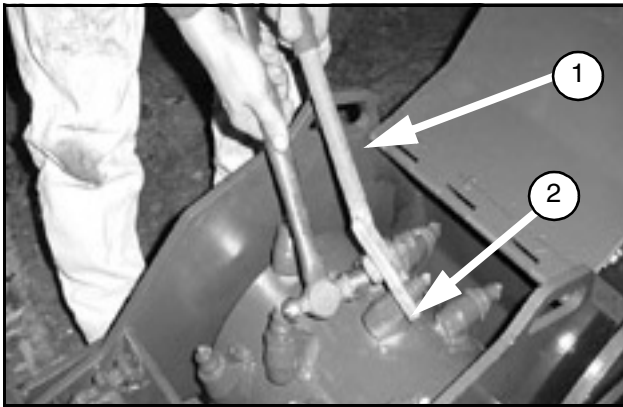

Figure 38.

PICK INSTALLATION

1. Insert the pick tool (1) into the slot on the pick (2) as shown in Figure 39.
2. Drive the pick into the holder by striking the tool on the circular protrusion.

NOTICE

■ Do not install the pick by hitting the point of the pick as this may cause damage to the pick and premature failure.

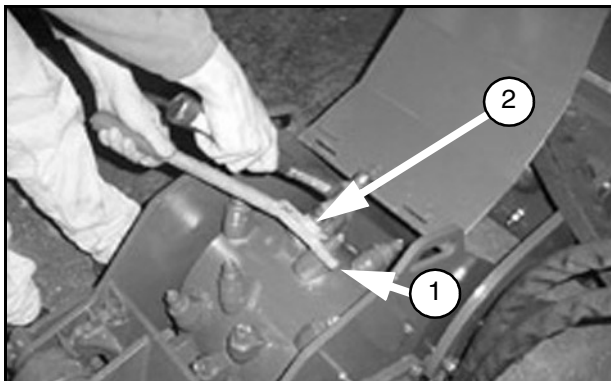

Figure 39.

LUBRICATION

All grease points should be serviced after 40 hours of operation:

- Depth jack (1)
- Front and rear wheels (2)
- Depth skid pivot (3)
- Chassis pivot pin (4)
- Dead-shaft bearing (5)

To grease the dead-shaft bearing set the planer to zero depth and rotate the drum until the grease fitting is facing down.

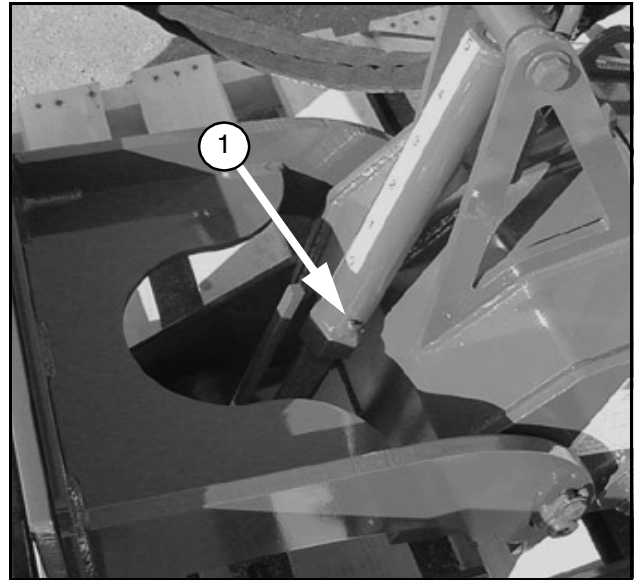

Figure 40. Depth Jack

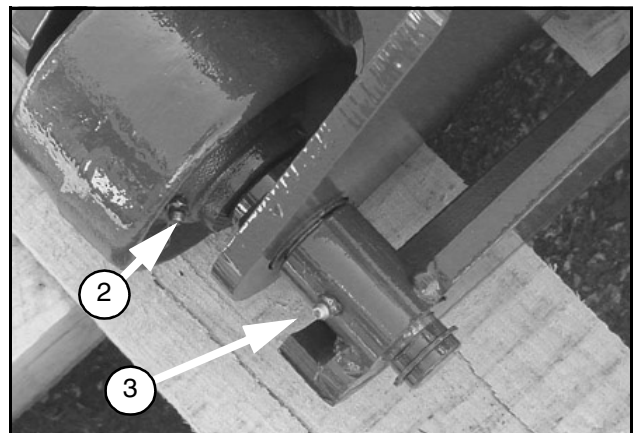

Figure 41.

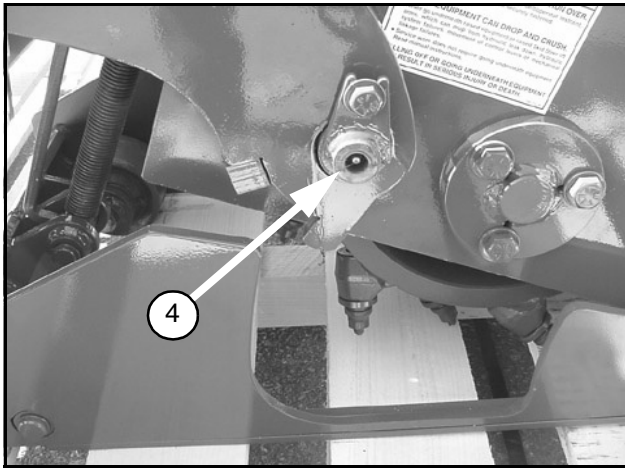

Figure 42. Chassis Pivot Pin

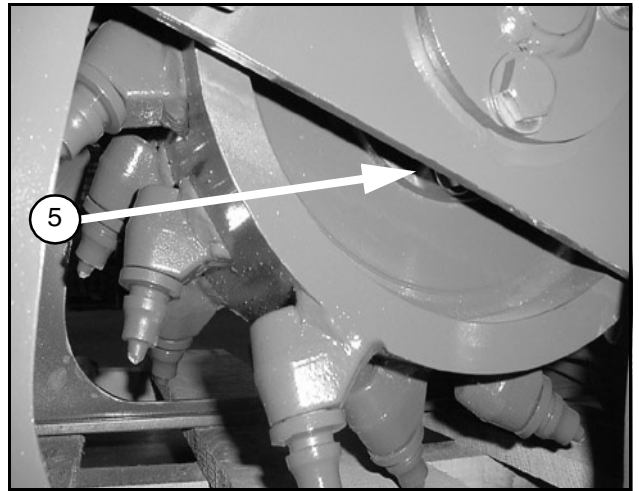

Figure 43. Dead-Shaft Bearing

PARTS INDEX

CP12FLA

CP12FLA ASSEMBLY	25
CP12FLA ASSEMBLY - NEW HOLLAND	26
BASE ASSEMBLY	27
CHASSIS ASSEMBLY	28
DRUM ASSEMBLY	29
VALVE ASSEMBLY	29
DRUM / DRIVE ASSEMBLY	30
HYDRAULIC ASSEMBLY	31
HYDRAULIC ASSEMBLY - NEW HOLLAND	32
DECAL PLACEMENT	33
DECAL PLACEMENT - NEW HOLLAND	34

CP12FLA ASSEMBLY

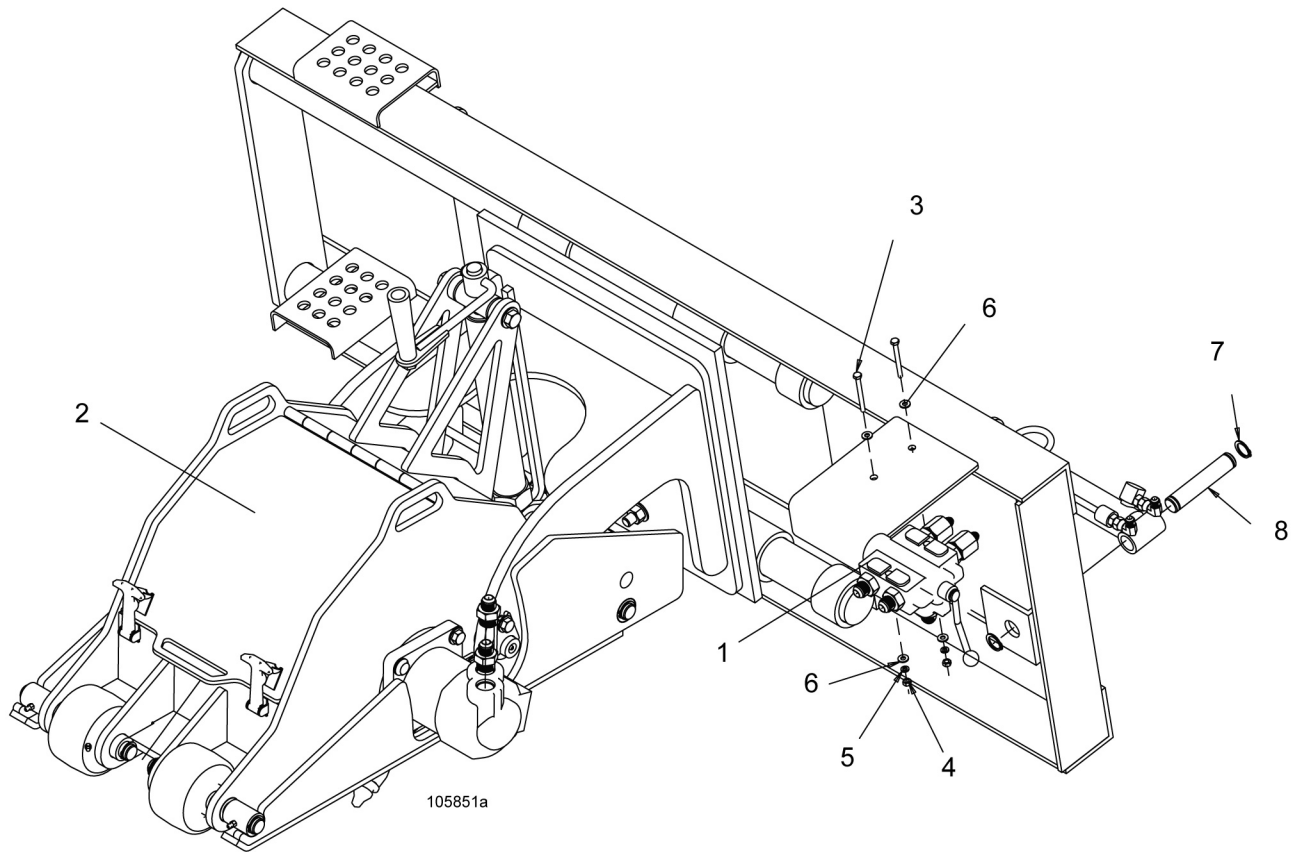

REF	PART	QTY	DESCRIPTION
1	----	1	Hydraulic assembly (see page 31)
2	----	1	Base unit assembly (see page 27)
3	300064 *	2	Bolt, 1/4 - 20 X 2-3/4 GR5 PLT
4	5288 *	2	Nut, 1/4 - 20 GR2 PLT
5	1985 *	2	Washer, 1/4 lock PLT
6	5336 *	4	Washer, 1/4 flat PLT
7	M0003	3	Retaining ring, 1" external HD
8	T1035-1	1	Pin, 1 X 5.17 S.R. 4.5
			* Standard hardware, obtain locally

CP12FLA - NEW HOLLAND

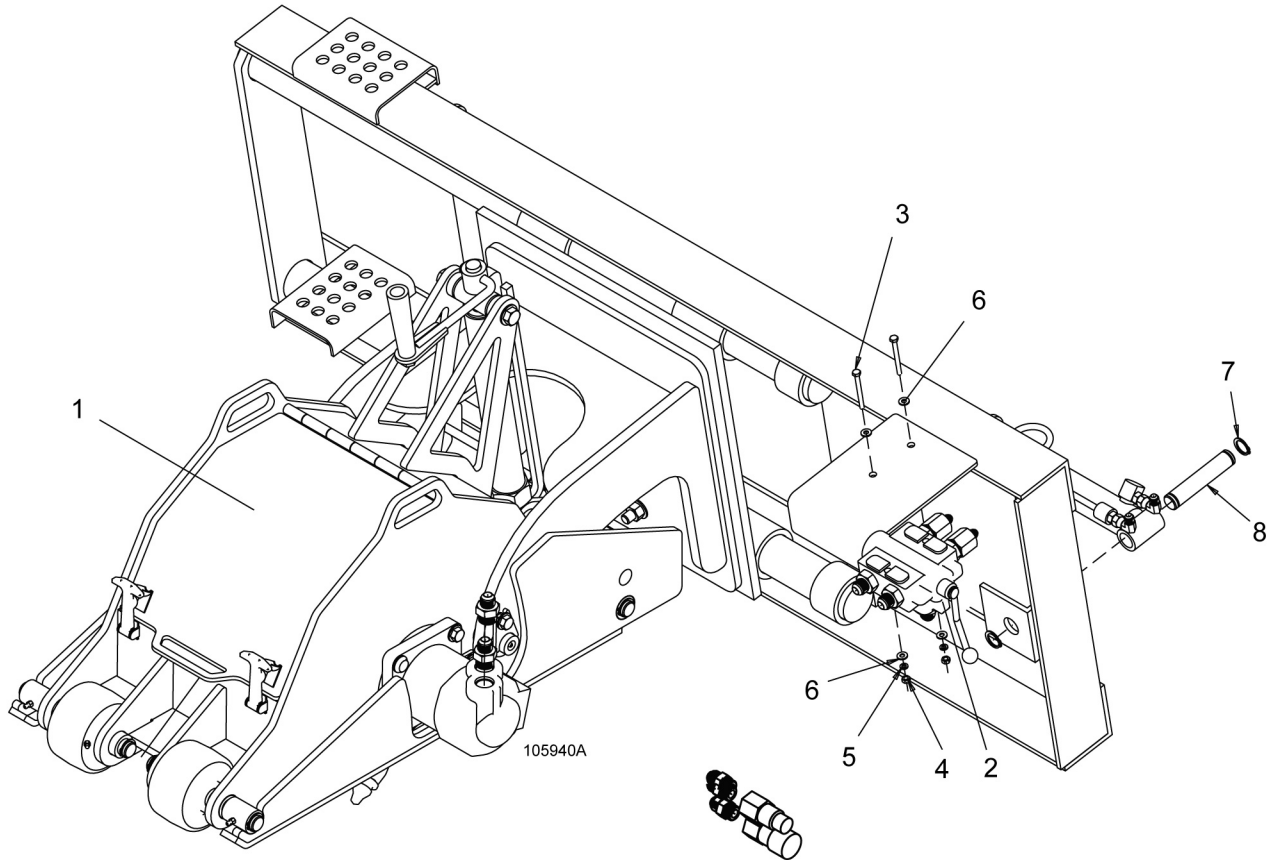

REF	PART	QTY	DESCRIPTION
1	----	1	Base unit assembly (see page 27)
2	----	1	Hydraulic assembly (see page 32)
3	300064 *	2	Bolt, 1/4 - 20 X 2-3/4 GR5 PLT
4	5288 *	2	Nut, 1/4 - 20 GR2 PLT
5	1985 *	2	Washer, 1/4 lock PLT
6	5336 *	4	Washer, 1/4 flat PLT
7	M0003	3	Retaining ring, 1" external HD
8	T1035-1	1	Pin, 1 X 5.17 S.R. 4.5
			* Standard hardware, obtain locally

BASE ASSEMBLY

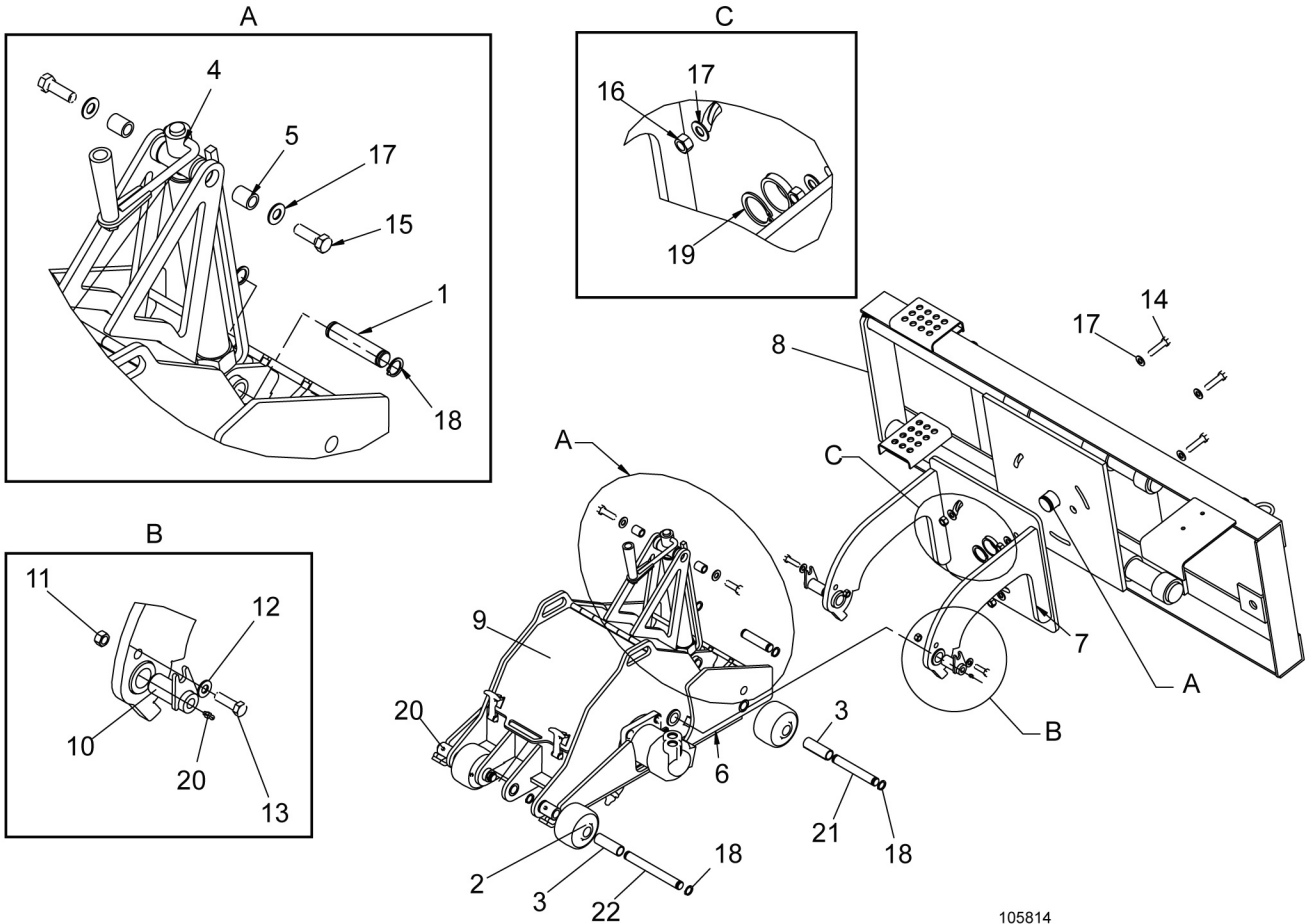

105814

REF	PART	QTY	DESCRIPTION	REF	PART	QTY	DESCRIPTION
1	100503	1	Pin, .933 X 4.44 S.R. 3.90	12	855	* 2	Washer, 1/2 lock ZP
2	100594	4	Wheel assembly	13	59009	2	Bolt, 1/2 - 13 X 1-3/4 GR8
3	101218	4	Bushing, wheel 1.03 X 1.25 X 3.7	14	11854	3	Bolt, 5/8 - 11 X 2-1/2 GR8 PLT
4	105427	1	Depth jack assembly	15	59001	2	Bolt, 5/8 - 11 X 2 GR8 PLT
5	105451	2	Boss, jack	16	B1015	3	Nut, 5/8 - 11 Stover GR5
6	105631	1	Depth skid weldment	17	B1021	8	Washer, 5/8 flat SAE PLT HRD
7	105646	1	Backplate weldment	18	M0003	10	Retaining ring, 1" external HD
8	105660	1	Attach frame weldment	19	M0042	1	Retaining ring, 2" EXT. PLT.
9	105811	1	Chassis assembly	20	M0114	* 4	Zerk, grease 1/4 - 28 ST
10	105818	2	Pin, flag 1.25 X 2.625	21	T1037	2	Pin, 1 X 6.25
11	B0815	2	Nut, 1/2 -13 Stover PLT GR5	22	T1108	2	Pin, 1 X 8.93 X 8.3 S.R. 6.37

* Standard hardware, obtain locally

CHASSIS ASSEMBLY

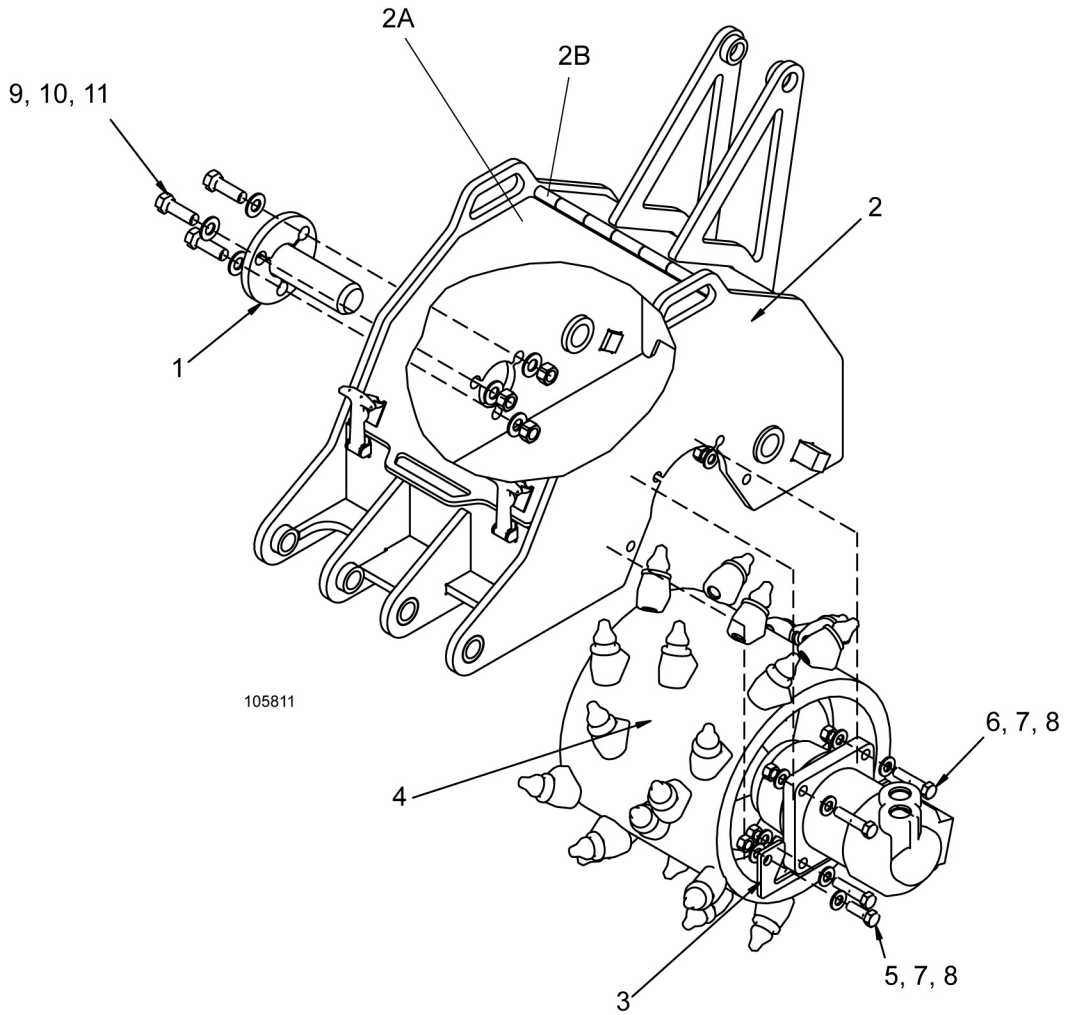

REF	PART	QTY	DESCRIPTION
1	100565	1	Dead-Shaft weldment
2	105635	1	Chassis weldment CP12A
2A	1016975	1	Lid weldment, CP12
2B	101659	1	Hinge, lid CP12
3	105650	1	Motor mount weldment
4	----	1	Drum / Drive assembly CP12 (see page 30)
5	21666	2	Bolt, 1/2 - 13 X 1-1/2 GR8 PLT
6	21527	4	Bolt, 1/2 - 13 X 2-1/4 HEX GR8 PLT
7	B0815	2	Nut, 1/2 - 13 Stover plt GR5
8	57816	12	Washer, 1/2 flat SAE hrd
9	59001	3	Bolt, 5/8 - 11 X 2 GR8 PLT
10	B1015	3	Nut, 5/8 - 11 Stover GR5
11	B1021	6	Washer, 5/8 flat SAE plt hrd

DRUM ASSEMBLY

REF	PART	QTY	DESCRIPTION
1	----	1	Drum weldment, 12"
2	1024801	28	Pick, asphalt kennamental RP18
3	104247	10	Stud, bearing 1/2"

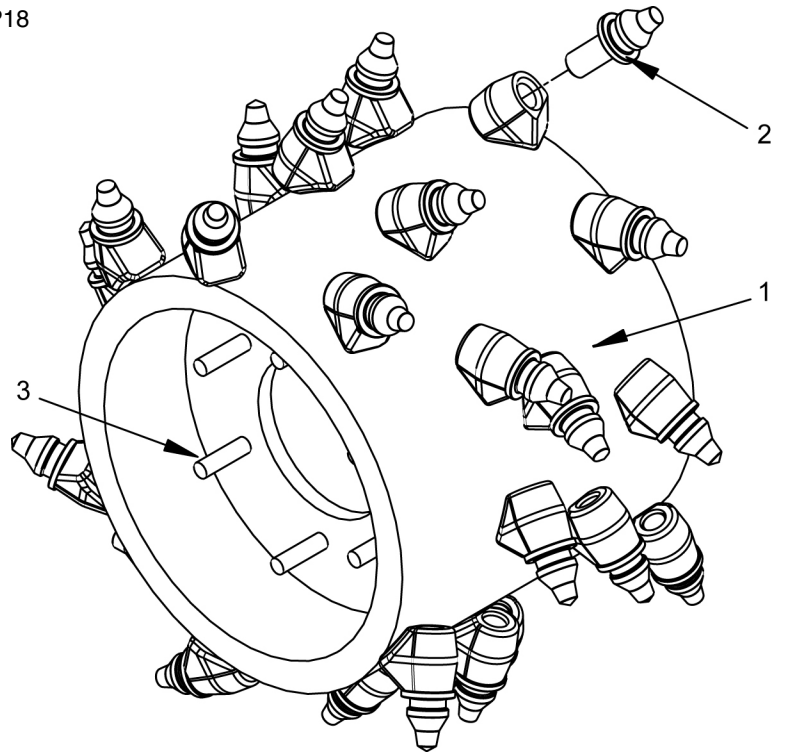

VALVE ASSEMBLY

REF	PART	QTY	DESCRIPTION
1	F1006	2	Fitting, 12 OM X 12 FLM ST
2	F1132	2	Fitting, 12 FLF X 6 FLM ST
3	F1140	4	Fitting, 12 OM X 10 FLM ST
4	1004261	1	Valve Dbl selector

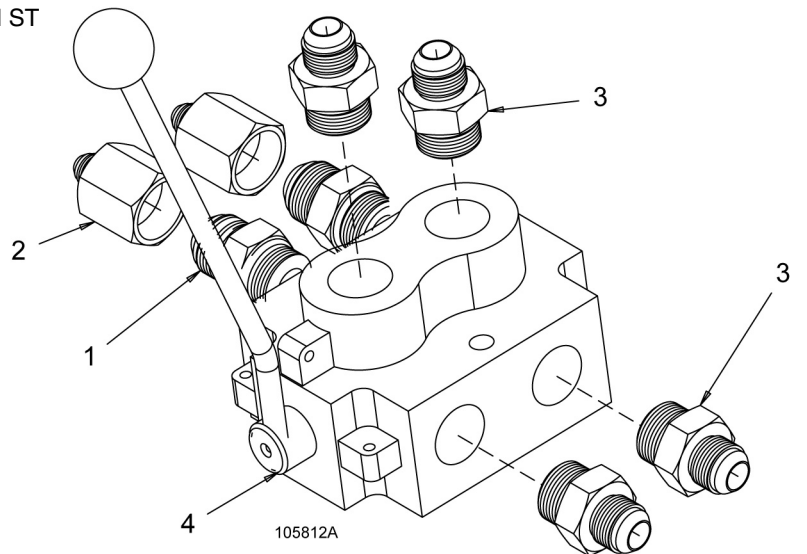

DRUM / DRIVE ASSEMBLY

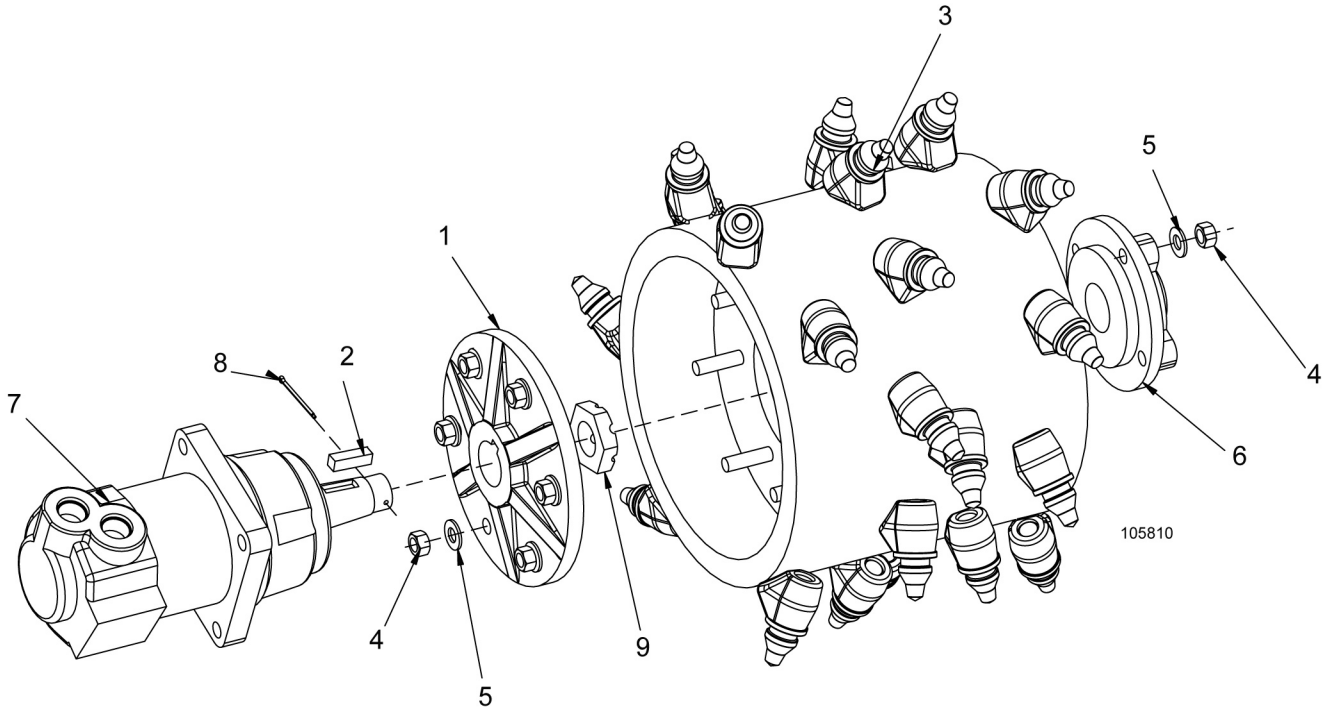

REF	PART	QTY	DESCRIPTION
1	100357	1	Hub, drive
2	102872	1	Key, 7/16 X 7/16 X 1-1/2
3	102670412	1	CPA12 Drum w/picks kennametal
4	B0816	10	Nut, 1/2 - 20 Stover
5	57816	10	Washer, 1/2 flat SAE HRD
6	BB014	1	Bearing, outer 1-3/4
7	HC319	1	Motor, Char-Lynn 4000
8	M0021	*	Pin, cotter 1/8 X 2
9	S0100872	1	Nut, 1-1/4 - 18 castle

* Standard hardware, obtain locally

HYDRAULIC ASSEMBLY

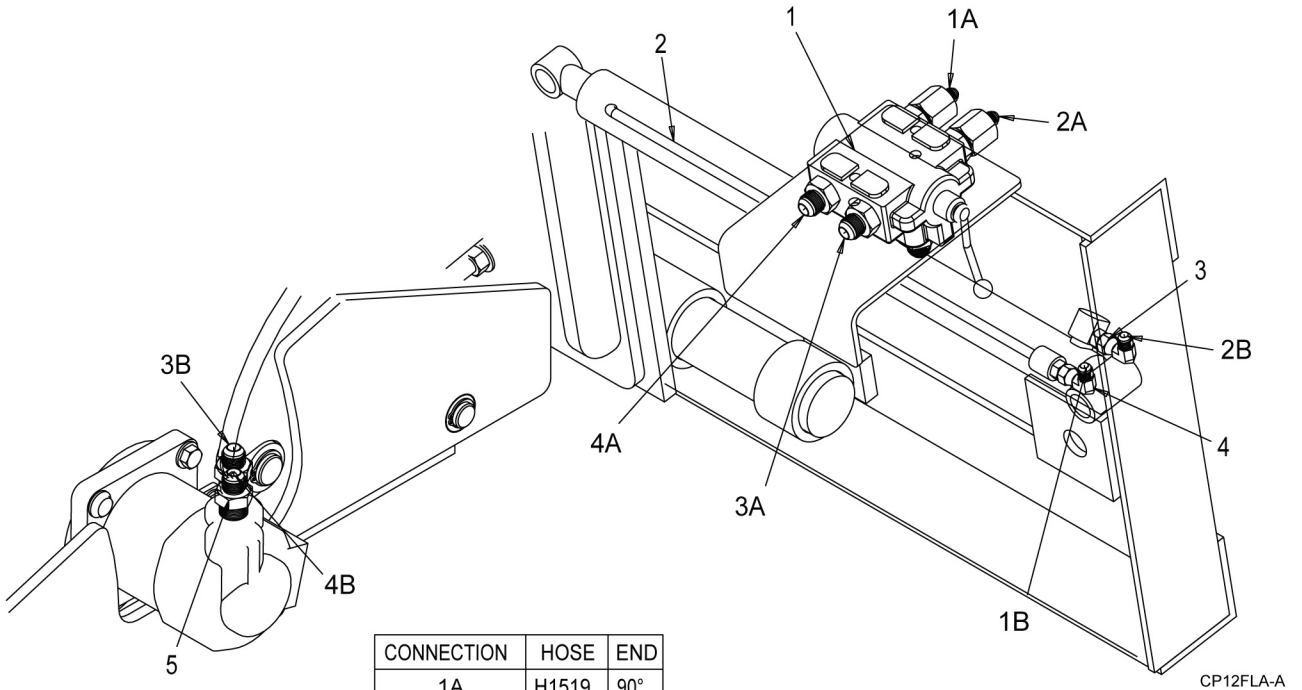

CONNECTION	HOSE	END
1A	H1519	90°
1B	H1519	ST.
2A	H1519	90°
2B	H1519	ST.
3A	H1457	90°
3B	H1457	ST.
4A	H1457	90°
4B	H1457	ST.
5A	H1458	90°
5B	H1458	ST.
6A	H1458	90°
6B	H1458	ST.

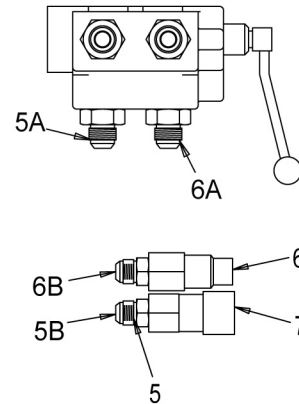

REF	PART	QTY	DESCRIPTION
1	----	1	Valve assembly (see page 29)
2	C2201	1	Cylinder, hydraulic 2 X 22
3	F1044	2	Fitting, 6OM X 6FLM ST
4	F1057	2	Fitting, 6FLF X 6FLM 90°
5	F1140	4	Fitting, 12OM X 10FLM ST
6	HC414	1	QD 1/2" Male flush face
7	HC415	1	QD 1/2" Female flush face
	H1137	1	Hose #4 x 12" 6 FLF 90 x 6 FLF R2 (not shown)
	H1188	1	Hose #10 x 60" 10 FLF 90 x 10 FLF R2 (not shown)
	H1190	1	Hose #10 x 52" 10 FLF x 10 FLF 90 R2 (not shown)

HYDRAULIC ASSEMBLY NEW HOLLAND

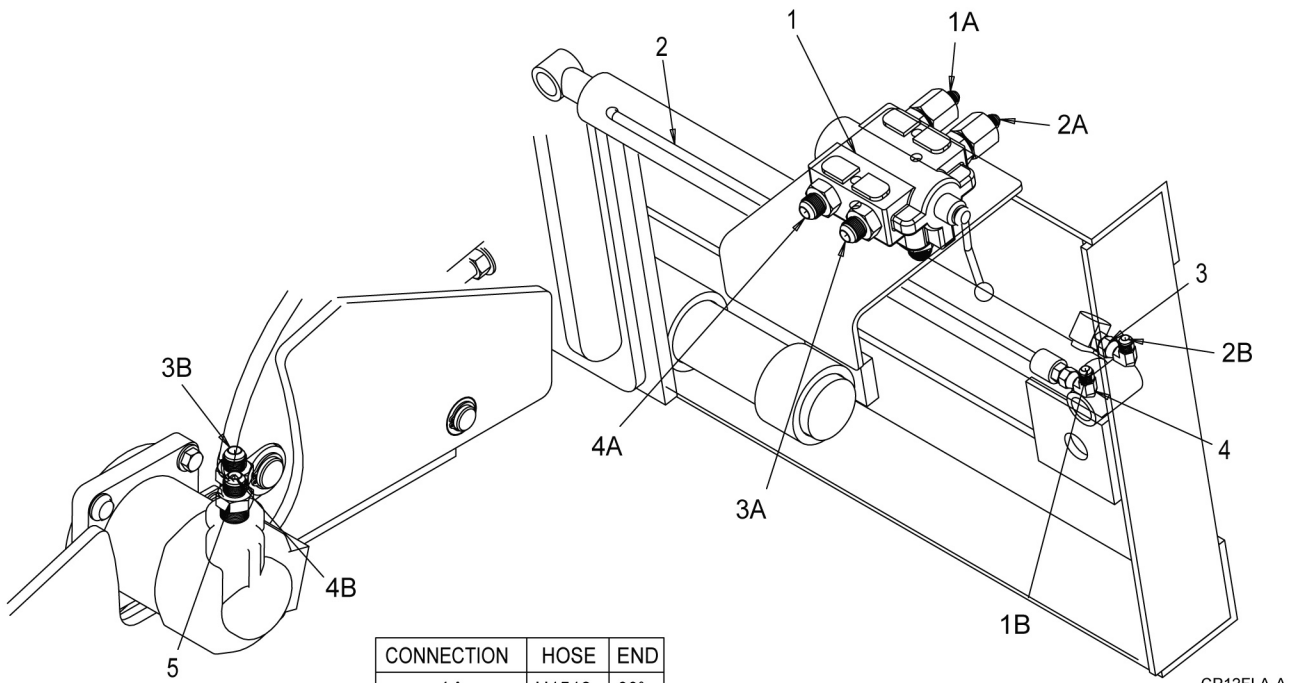

CONNECTION	HOSE	END
1A	H1519	90°
1B	H1519	ST.
2A	H1519	90°
2B	H1519	ST.
3A	H1457	90°
3B	H1457	ST.
4A	H1457	90°
4B	H1457	ST.
5A	H1458	90°
5B	H1458	ST.
6A	H1458	90°
6B	H1458	ST.

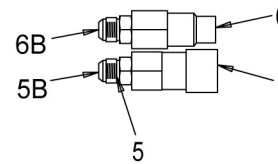
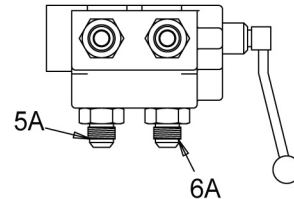

REF	PART	QTY	DESCRIPTION
1	----	1	Valve assembly (see page 29)
2	C2201	1	Cylinder, hydraulic 2 X 22
3	F1044	2	Fitting, 6 OM X 6 FLM ST
4	F1057	2	Fitting, 6 FLF X 6 FLM 90°
5	F1140	4	Fitting, 12 OM X 10 FLM ST
6	HC414	1	QD 1/2" Male flush face
7	HC415	1	QD 1/2" Female flush face
	H1137	1	Hose #4 x 12" 6 FLF 90 x 6 FLF R2 (not shown)
	H1188	1	Hose #10 x 60" 10 FLF 90 x 10 FLF R2 (not shown)
	H1190	1	Hose #10 x 52" 10 FLF x 10 FLF 90 R2 (not shown)

DECAL PLACEMENT

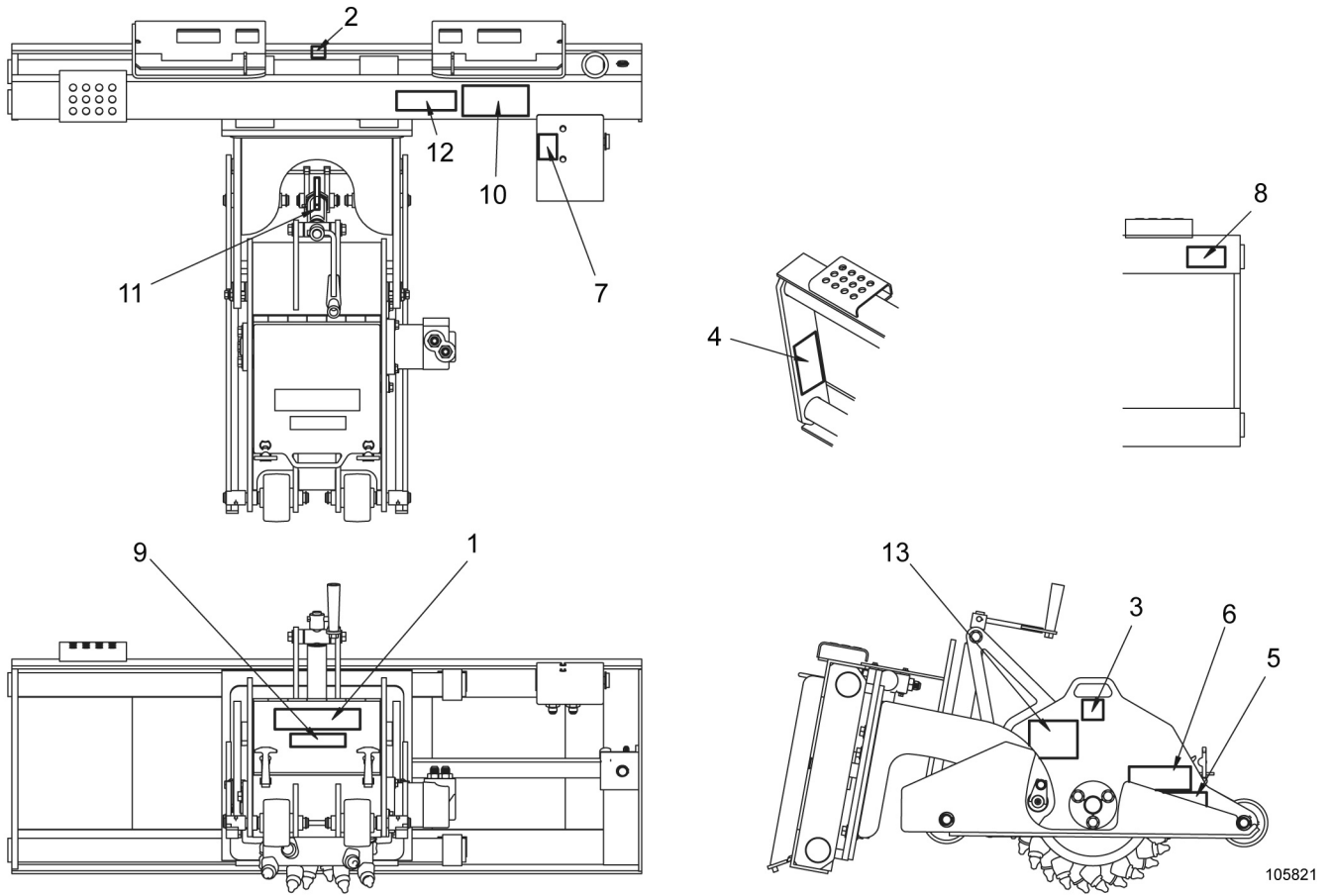

105821

REF	PART	QTY	DESCRIPTION
1	D0119	1	Decal, Alitec white with black
2	D0157	1	Decal, Tie down
3	D0158	2	Decal, Lift point
4	D0192	1	Decal, Pinch point
5	D0193	2	Decal, Rotating cutter drum
6	D0195	2	Decal, Flying objects
7	D0209	1	Decal, No step
8	----	1	Serial number plate
9	----	1	Decal, CP12LFA
10	D0404	1	Decal, Warning, Power unit operation
11	D0410	1	Decal, Depth CP12LFA
12	19924	1	Decal, Warning, High pressure hydraulics
13	54519	1	Decal, Warning, Skid steer warnings

DECAL PLACEMENT NEW HOLLAND

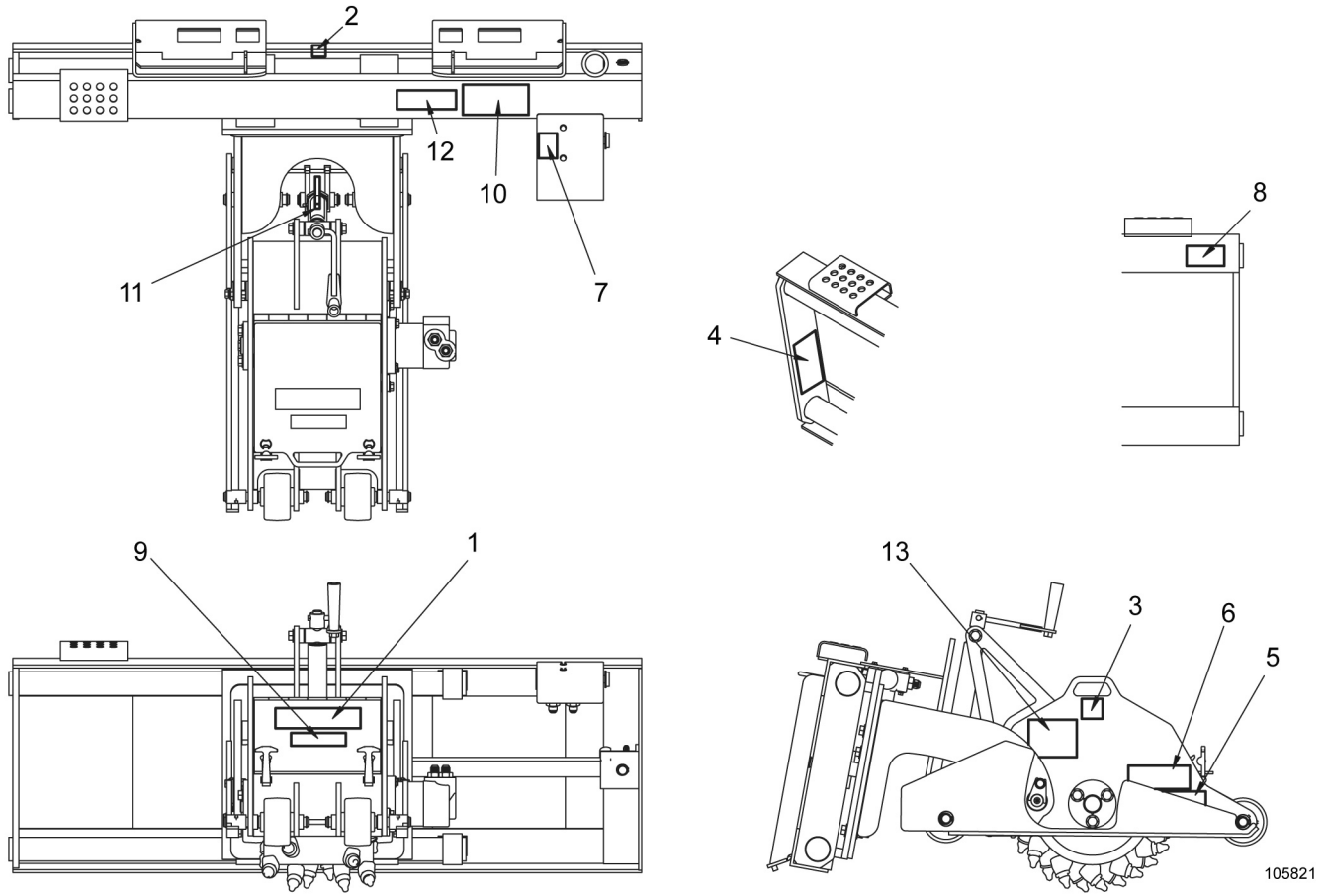

REF	PART	QTY	DESCRIPTION
1	-----	1	Decal, New Holland 11.33 X 2.07 Yellow
2	D0157	1	Decal, Tie down
3	D0158	2	Decal, Lift point
4	D0192	1	Decal, Pinch point
5	D0193	2	Decal, Rotating cutter drum
6	D0195	2	Decal, Flying objects
7	D0209	1	Decal, No step
8	-----	1	Serial number plate
9	-----	1	Decal, CP12 4.5 X 1.5 NH Yellow
10	D0404	1	Decal, Warning, Power unit operation
11	D0410	1	Decal, Depth CP12LFA
12	19924	1	Decal, Warning, High pressure hydraulics
13	54519	1	Decal, Warning, Skid steer warnings
16	D0376	1	Decal, Alitec 5.43 X 1.44 Yellow

FITTING TORQUE CHART

Always tighten fittings to these values unless a different torque value is listed for a specific service procedure.

Make sure fastener threads are clean and threads are engaged properly.

All torque values are adopted from SAE J514 and SAE J1453.

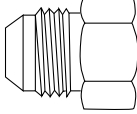
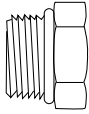
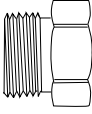
			
Size	SAE (JIC) 37° Flare Thread Size	O-Ring Style Straight Thread Size	Seal-Lok Thread
2	5/16 - 24	5/16 - 24	---
3	3/8 - 24	3/8 - 24	---
4	7/16 - 20	7/16 - 20	9/16 - 18
5	1/2 - 20	1/2 - 20	---
6	9/16 - 18	9/16 - 18	11/16 - 16
8	3/4 - 16	3/4 - 16	13/16 - 16
10	7/8 - 14	7/8 - 14	1 - 14
12	1-1/16 - 12	1-1/16 - 12	1-3/16 - 12
14	1-3/16 - 12	1-3/16 - 12	---
16	1-5/16 - 12	1-5/16 - 12	1-7/16 - 12
20	1-5/8 - 12	1-5/8 - 12	1-11/16 - 12
24	1-7/8 - 12	1-7/8 - 12	2 - 12
32	2-1/2 - 12	2-1/2 - 12	---

SAE Dash Size	TORQUE					
	SAE 37° Flare		O-Ring Straight Thread		Seal-Lok	
	Lbs.-Ft.	N-m	Lbs.-Ft.	N-m	Lbs.-Ft.	N-m
2	4	5	4	5	---	---
3	8	11	9	12	---	---
4	12	16	16	22	18	25
5	15	20	22	30	---	---
6	18	25	35	48	27	37
8	37	50	60	82	40	54
10	48	65	105	143	63	86
12	74	100	140	190	92	125
14	88	120	184	250	---	---
16	100	135	221	300	122	165
20	133	180	258	350	147	200
24	166	225	317	430	166	225
32	236	320	---	---	---	---

QUICK COUPLER KITS

		High-Flow with Auxiliary		High-Flow with No Auxiliary		Low-Flow	
Make		QC Kit	Description	QC Kit	Description	QC Kit	Description
Bobcat		HC356	Flush Face	HC355	Flush Face	HC357	Flush Face
	Vintage					HC243 HC211	Poppet Ag Ball Valve
Case		1013825	Flush Face	HC212	Flush Face	HC279	Flush Face
	Vintage	HC278 HC209	Flush Face Flush Face & Ag Ball Valve			HC211	Ag Ball Valve
Cat		HC538	Flush Face	1014196	Flush Face	1014197	Flush Face
Daewoo		HC209	Flush Face	HC212	Flush Face	HC211	Ag Ball Valve
Gehl		HC398	Flush Face	1014195	Flush Face	HC400	Flush Face
	Vintage			HC305	Poppet & Ag Ball		
John Deere		1014198	Flush Face	1013826	Flush Face	HC310	Flush Face
Komatsu		1013834	Flush Face	1013833	Flush Face	1013835	Flush Face
New Holland		1014199	Flush Face	HC308	Flush Face	HC310	Flush Face
Scat Trak		HC537	Flush Face			HC243	Poppet

QUICK COUPLER KIT COMPONENTS

QC KIT	Includes	Style	Male/Female	Body Size	Hose End
HC209	HC193	Flush Face	Male	3/4	SAE #12 O-ring
	HC194	Flush Face	Female	3/4	SAE #12 O-ring
	HC195	Ag Ball	Female	1/2	1/2-14 NPT
	HC196	Ag Ball	Male	1/2	1/2-14 NPT
	HC197	Flush Face	Female	1/2	SAE #10 O-ring
HC211	HC195	Ag Ball	Female	1/2	1/2-14 NPT
	HC196	Ag Ball	Male	1/2	1/2-14 NPT
HC212	HC193	Flush Face	Male	3/4	SAE #12 O-ring
	HC194	Flush Face	Female	3/4	SAE #12 O-ring
	HC197	Flush Face	Female	1/2	SAE #10 O-ring
HC278	HC193	Flush Face	Male	3/4	SAE #12 O-ring
	HC194	Flush Face	Female	3/4	SAE #12 O-ring
	HC197	Flush Face	Female	1/2	SAE #10 O-ring
	HC201	Flush Face	Male	1/2	SAE #10 O-ring
HC279	HC197	Flush Face	Female	1/2	SAE #10 O-ring
	HC201	Flush Face	Male	1/2	SAE #10 O-ring

QUICK COUPLER KIT COMPONENTS

QC KIT	Includes	Style	Male/Female	Body Size	Hose End
HC308	HC416	Flush Face	Female	5/8	SAE #12 O-ring
	HC417	Flush Face	Male	5/8	SAE #12 O-ring
	HC418	Flush Face	Male	3/8	SAE #8 O-ring
HC310	HC414	Flush Face	Male	1/2	SAE #12 O-ring
	HC415	Flush Face	Female	1/2	SAE #12 O-ring
HC355	HC344	Flush Face	Male	12 mm	SAE #12 O-ring
	HC345	Flush Face	Female	12 mm	SAE #12 O-ring
	HC346	Flush Face	Female	9 mm	SAE #8 O-ring
HC356	HC342	Flush Face	Female	7 mm	SAE #6 O-ring
	HC343	Flush Face	Male	7 mm	SAE #6 O-ring
	HC344	Flush Face	Male	12 mm	SAE #12 O-ring
	HC345	Flush Face	Female	12 mm	SAE #12 O-ring
	HC346	Flush Face	Female	9 mm	SAE #8 O-ring
HC357	HC344	Flush Face	Male	12 mm	SAE #12 O-ring
	HC345	Flush Face	Female	12 mm	SAE #12 O-ring
HC398	HC344	Flush Face	Male	12 mm	SAE #12 O-ring
	HC345	Flush Face	Female	12 mm	SAE #12 O-ring
	HC346	Flush Face	Female	9 mm	SAE #8 O-ring
HC400	HC344	Flush Face	Male	12 mm	SAE #12 O-ring
	HC345	Flush Face	Female	12 mm	SAE #12 O-ring
HC537	HC415	Flush Face	Female	1/2	SAE #12 O-ring
	HC416	Flush Face	Female	5/8	SAE #12 O-ring
	HC417	Flush Face	Male	5/8	SAE #12 O-ring
	HC418	Flush Face	Male	3/8	SAE #8 O-ring
HC538	HC521	Flush Face	Female	16 mm	SAE #12 O-ring
	HC522	Flush Face	Male	16 mm	SAE #12 O-ring
	1532994	Flush Face	Female	3/4	SAE #12 O-ring
	1532995	Flush Face	Male	3/4	SAE #12 O-ring
	1532997	Flush Face	Female	1/2	SAE #8 O-ring
1013825	HC417	Flush Face	Male	5/8	SAE #12 O-ring
	HC418	Flush Face	Male	3/8	SAE #8 O-ring
	HC545	Flush Face	Female	5/8	SAE #12 O-ring
	HC546	Flush Face	Female	1/2	SAE #10 O-ring
	HC547	Flush Face	Male	1/2	SAE #10 O-ring
1013826	HC343	Flush Face	Male	7 mm	SAE #6 O-ring
	HC521	Flush Face	Female	16 mm	SAE #12 O-ring
	HC522	Flush Face	Male	16 mm	SAE #12 O-ring
1013833	HC415	Flush Face	Female	1/2	SAE #12 O-ring
	HC521	Flush Face	Female	16 mm	SAE #12 O-ring
	HC522	Flush Face	Male	16 mm	SAE #12 O-ring

QUICK COUPLER KIT COMPONENTS

QC KIT	Includes	Style	Male/Female	Body Size	Hose End
1013834	HC414	Flush Face	Male	1/2	SAE #12 O-ring
	HC415	Flush Face	Female	1/2	SAE #12 O-ring
	HC521	Flush Face	Female	16 mm	SAE #12 O-ring
	HC522	Flush Face	Male	16 mm	SAE #12 O-ring
1013835	46058	Flush Face	M/F Set	3/4	SAE #12 O-ring
1014195	HC344	Flush Face	Male	12 mm	SAE #12 O-ring
	HC345	Flush Face	Female	12 mm	SAE #12 O-ring
	HC346	Flush Face	Female	9 mm	SAE #8 O-ring
1014196	HC521	Flush Face	Female	16 mm	SAE #12 O-ring
	HC522	Flush Face	Male	16 mm	SAE #12 O-ring
	1532997	Flush Face	Female	1/2	SAE #8 O-ring
1014197	1532994	Flush Face	Female	3/4	SAE #10 O-ring
	1532995	Flush Face	Male	3/4	SAE #10 O-ring
1014198	HC343	Flush Face	Male	7 mm	SAE #6 O-ring
	HC414	Flush Face	Male	1/2	SAE #12 O-ring
	HC415	Flush Face	Female	1/2	SAE #12 O-ring
	HC521	Flush Face	Female	16 mm	SAE #12 O-ring
	HC522	Flush Face	Male	16 mm	SAE #12 O-ring
1014199	HC414	Flush Face	Male	1/2	SAE #12 O-ring
	HC415	Flush Face	Female	1/2	SAE #12 O-ring
	HC416	Flush Face	Female	5/8	SAE #12 O-ring
	HC417	Flush Face	Male	5/8	SAE #12 O-ring
	HC418	Flush Face	Male	3/8	SAE #8 O-ring

BOLT TORQUE CHART

Always tighten hardware to these values unless a different torque value or tightening procedure is listed for a specific application.

Fasteners must always be replaced with the same grade as specified in the manual parts list.

Always use the proper tool for tightening hardware: SAE for SAE hardware and Metric for metric hardware.

Make sure fastener threads are clean and you start thread engagement properly.

All torque values are given to specifications used on hardware defined by SAE J1701 MAR 99 & J1701M JUL 96.

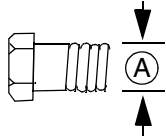

SAE SERIES TORQUE CHART



SAE Grade 2
(No Dashes)

SAE Bolt Head Identification



SAE Grade 5
(3 Radial Dashes)



SAE Grade 8
(6 Radial Dashes)

Ⓐ Diameter (Inches)	Wrench Size	MARKING ON HEAD					
		SAE 2		SAE 5		SAE 8	
		lbs-ft	N-m	lbs-ft	N-m	lbs-ft	N-m
1/4"	7/16"	6	8	10	13	14	18
5/16"	1/2"	12	17	19	26	27	37
3/8"	9/16"	23	31	35	47	49	67
7/16"	5/8"	36	48	55	75	78	106
1/2"	3/4"	55	75	85	115	120	163
9/16"	13/16"	78	106	121	164	171	232
5/8"	15/16"	110	149	170	230	240	325
3/4"	1-1/8"	192	261	297	403	420	569
7/8"	1-5/16"	306	416	474	642	669	907
1"	1-1/2"	467	634	722	979	1020	1383

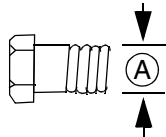

METRIC SERIES TORQUE CHART



8.8
Metric
Grade 8.8

Metric Bolt Head Identification



10.9
Metric
Grade 10.9

Ⓐ Diameter & Thread Pitch (Millimeters)	Wrench Size	Coarse Thread				Fine Thread				Ⓐ Diameter & Thread Pitch (Millimeters)
		Marking on Head				Marking on Head				
		Metric 8.8		Metric 10.9		Metric 8.8		Metric 10.9		
		N-m	lbs-ft	N-m	lbs-ft	N-m	lbs-ft	N-m	lbs-ft	
6 x 1.0	10 mm	8	6	11	8	8	6	11	8	6 x 1.0
8 x 1.25	13 mm	20	15	27	20	21	16	29	22	8 x 1.0
10 x 1.5	16 mm	39	29	54	40	41	30	57	42	10 x 1.25
12 x 1.75	18 mm	68	50	94	70	75	55	103	76	12 x 1.25
14 x 2.0	21 mm	109	80	151	111	118	87	163	120	14 x 1.5
16 x 2.0	24 mm	169	125	234	173	181	133	250	184	16 x 1.5
18 x 2.5	27 mm	234	172	323	239	263	194	363	268	18 x 1.5
20 x 2.5	30 mm	330	244	457	337	367	270	507	374	20 x 1.5
22 x 2.5	34 mm	451	332	623	460	495	365	684	505	22 x 1.5
24 x 3.0	36 mm	571	421	790	583	623	459	861	635	24 x 2.0
30 x 3.0	46 mm	1175	867	1626	1199	1258	928	1740	1283	30 x 2.0

Typical Washer Installations

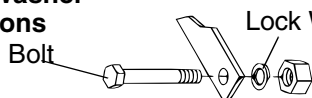

Lock Washer

Flat Washer

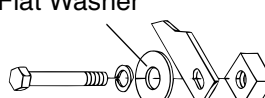

8/9/00

BOLT SIZE CHART

NOTE: Chart shows bolt thread sizes and corresponding head (wrench) sizes for standard SAE and metric bolts.

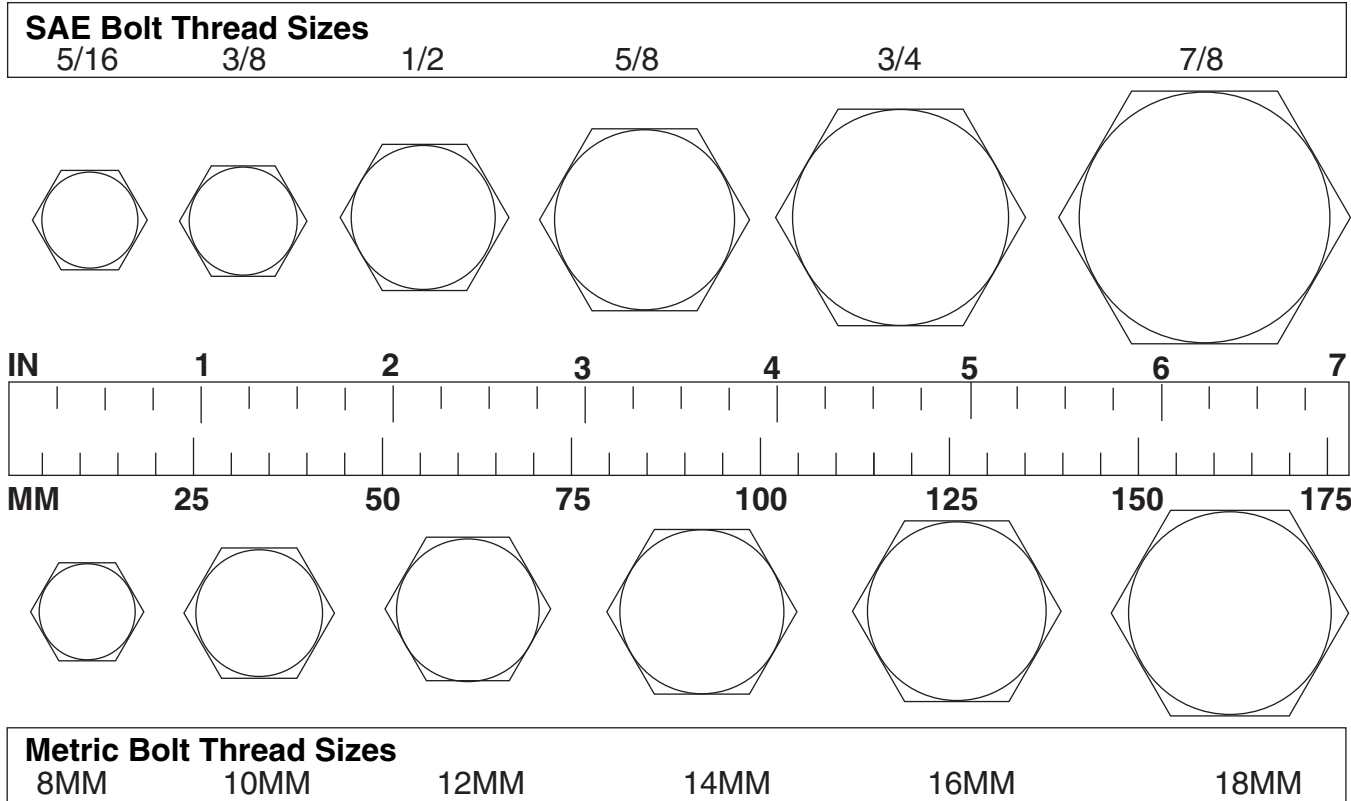

ABBREVIATIONS

AG Agriculture
 ASABE American Society of Agricultural & Biological Engineers (formerly ASAE)
 ASAE..... American Society of Agricultural Engineers
 ATF.....Automatic Transmission Fluid
 BSPP..... British Standard Pipe Parallel
 BSPTM..... British Standard Pipe Tapered Male
 CV Constant Velocity
 CCW..... Counter-Clockwise
 CW Clockwise
 F Female
 FT..... Full Thread
 GA Gauge
 GR (5, etc.)..... Grade (5, etc.)
 HHCS Hex Head Cap Screw
 HT Heat-Treated
 JIC..... Joint Industry Council 37° Degree Flare
 LH..... Left Hand
 LT Left
 m Meter
 mm Millimeter
 M Male

MPa Mega Pascal
 N Newton
 NC..... National Coarse
 NF National Fine
 NPSM National Pipe Straight Mechanical
 NPT.....National Pipe Tapered
 NPT SWF..... National Pipe Tapered Swivel Female
 ORBM O-Ring Boss - Male
 P Pitch
 PBY.....Power-Beyond
 psi Pounds per Square Inch
 PTO.....Power Take Off
 QD Quick Disconnect
 RH..... Right Hand
 ROPS..... Roll-Over Protective Structure
 RPM.....Revolutions Per Minute
 RT Right
 SAE..... Society of Automotive Engineers
 UNC Unified Coarse
 UNF Unified Fine
 UNS Unified Special

INDEX

GENERAL

- Abbreviations 37
- Bolt Size Chart 37
- Bolt Torque Chart 36
- Fitting Torque Chart 35
- Introduction 2
- Obtaining Replacement Manuals 2
- Warranty
 - Product 39
 - Replacement Parts 40

OPERATION

- Adjust Head Angle 12
- Adjusting Planing Depth 11
- Attaching Planer 10
- Cleaning 13
- Pre-Operation Check List 10
- Sideshaft Adjustment 12
- Transporting 13

PARTS

- Parts Index 24

SAFETY

- Safety Rules 5
- Safety Symbols Explained 2

SERVICE 16

- Bearing Installation 21
- Bearing Removal 21
- Drum Installation 18
- Drum Removal 16
- Lubrication 22
- Motor Installation 21
- Motor Removal 20
- Pick Installation 22
- Pick Removal 22
- Pivot Pin Installation 21
- Pivot Pin Removal 21
- Sideshift Cylinder Installation 16
- Sideshift Cylinder Removal 16

TROUBLESHOOTING 14

WARRANTY

(All Models Except Mow'n Machine™ Zero-Turn Mowers and Woods Boundary™ Utility Vehicles)

Please Enter Information Below and Save for Future Reference.

Date Purchased: _____ From (Dealer): _____
 Model Number: _____ Serial Number: _____

Woods Equipment Company ("WOODS") warrants this product to be free from defect in material and workmanship. Except as otherwise set forth below, the duration of this Warranty shall be for TWELVE (12) MONTHS COMMENCING ON THE DATE OF DELIVERY OF THE PRODUCT TO THE ORIGINAL PURCHASER.

Woods backhoe models BH70-X, BH80-X, and BH90-X are warranted for two (2) years from the date of delivery to the original purchaser.

The warranty periods for specific parts or conditions are listed below:

Part or Condition Warranted	Model Number	Duration (from date of delivery to the original purchaser)
Gearbox components	BW1260, BW1800	8 years
	BB48X, BB60X, BB72X, BB84X, BB600X, BB720X, BB840X, BB6000X, BB7200X, BB8400X, DS1260, DSO1260, DS1440, TS1680, BW126-3, BW180-3	6 years
	PHD25, PHD35, PHD65, PHD95, 2162, 3240, DS96, DS120, RCC42, RM550-2, RM660-2, RM990-3, PRD6000, PRD7200, PRD8400, 7144RD-2, 9180RD-2, 9204RD-2, S15CD, S20CD, S22CD, S25CD, S27CD	5 years
	RDC54, RD60, RD72	3 years (1 year if used in rental or commercial applications)
Blade spindles	RM550-2, RM660-2, RM990-3, PRD6000, PRD7200, PRD8400, 7144RD-2, 9180RD-2, 9204RD-2	3 years
Rust-through	BB600, BB720, BB840, BB6000, BB7200, BB8400, BW126-3, BW180-3, BW1260, BW1800, 2162, 3240, DS1260, DSO1260, DS1440, TS1680	10 years

Under no circumstances will this Warranty apply in the event that the product, in the good faith opinion of WOODS, has been subjected to improper operation, improper maintenance, misuse, or an accident. This Warranty does not apply in the event that the product has been materially modified or repaired by someone other than WOODS, a WOODS authorized dealer or distributor, and/or a WOODS authorized service center. This Warranty does not cover normal wear or tear, or normal maintenance items. This Warranty also does not cover repairs made with parts other than those obtainable through WOODS.

This Warranty is extended solely to the original purchaser of the product. Should the original purchaser sell or otherwise transfer this product to a third party, this Warranty does not transfer to the third party purchaser in any way. There are no third party beneficiaries of this Warranty.

WOODS makes no warranty, express or implied, with respect to engines, batteries, tires or other parts or accessories not manufactured by WOODS. Warranties for these items, if any, are provided separately by their respective manufacturers.

WOODS' obligation under this Warranty is limited to, at WOODS' option, the repair or replacement, free of charge, of the product if WOODS, in its sole discretion, deems it to be defective or in noncompliance with this Warranty. **The product must be returned to WOODS with proof of purchase within thirty (30) days after such defect or noncompliance is discovered or should have been discovered, routed through the dealer and distributor from whom the purchase was made, transportation charges prepaid.** WOODS shall complete such repair or replacement within a reasonable time after WOODS receives the product. **THERE ARE NO OTHER REMEDIES UNDER THIS WARRANTY. THE REMEDY OF REPAIR OR REPLACEMENT IS THE SOLE AND EXCLUSIVE REMEDY UNDER THIS WARRANTY.**

THERE ARE NO WARRANTIES WHICH EXTEND BEYOND THE DESCRIPTION ON THE FACE OF THIS WARRANTY. WOODS MAKES NO OTHER WARRANTY, EXPRESS OR IMPLIED, AND WOODS SPECIFICALLY DISCLAIMS ANY IMPLIED WARRANTY OF MERCHANTABILITY AND/OR ANY IMPLIED WARRANTY OF FITNESS FOR A PARTICULAR PURPOSE.

WOODS shall not be liable for any incidental or consequential losses, damages or expenses, arising directly or indirectly from the product, whether such claim is based upon breach of contract, breach of warranty, negligence, strict liability in tort or any other legal theory. Without limiting the generality of the foregoing, Woods specifically disclaims any damages relating to (i) lost profits, business, revenues or goodwill; (ii) loss of crops; (iii) loss because of delay in harvesting; (iv) any expense or loss incurred for labor, supplies, substitute machinery or rental; or (v) any other type of damage to property or economic loss.

This Warranty is subject to any existing conditions of supply which may directly affect WOODS' ability to obtain materials or manufacture replacement parts.

No agent, representative, dealer, distributor, serviceperson, salesperson, or employee of any company, including without limitation, WOODS, its authorized dealers, distributors, and service centers, is authorized to alter, modify, or enlarge this Warranty.

Answers to any questions regarding warranty service and locations may be obtained by contacting:

Woods Equipment Company
 2606 South Illinois Route 2
 Post Office Box 1000
 Oregon IL 61061
 800-319-6637 tel
 800-399-6637 fax
 www.WoodsEquipment.com



ALITEC™
BMP®
CENTRAL FABRICATORS®
GANNON®
GILL®
WAIN-ROY®
WOODS®



WARRANTY

(Replacement Parts For All Models Except Mow'n Machine™
Zero-Turn Mowers and Woods Boundary™ Utility Vehicles)

Woods Equipment Company ("WOODS") warrants this product to be free from defect in material and workmanship for a period of ninety (90) days from the date of delivery of the product to the original purchaser with the exception of V-belts, which will be free of defect in material and workmanship for a period of 12 months.

Under no circumstances will this Warranty apply in the event that the product, in the good faith opinion of WOODS, has been subjected to improper operation, improper maintenance, misuse, or an accident. This Warranty does not cover normal wear or tear, or normal maintenance items.

This Warranty is extended solely to the original purchaser of the product. Should the original purchaser sell or otherwise transfer this product to a third party, this Warranty does not transfer to the third party purchaser in any way. There are no third party beneficiaries of this Warranty.

WOODS' obligation under this Warranty is limited to, at WOODS' option, the repair or replacement, free of charge, of the product if WOODS, in its sole discretion, deems it to be defective or in noncompliance with this Warranty. **The product must be returned to WOODS with proof of purchase within thirty (30) days after such defect or noncompliance is discovered or should have been discovered, routed through the dealer and distributor from whom the purchase was made, transportation charges prepaid.** WOODS shall complete such repair or replacement within a reasonable time after WOODS receives the product. THERE ARE NO OTHER REMEDIES UNDER THIS WARRANTY. THE REMEDY OF REPAIR OR REPLACEMENT IS THE SOLE AND EXCLUSIVE REMEDY UNDER THIS WARRANTY.

THERE ARE NO WARRANTIES WHICH EXTEND BEYOND THE DESCRIPTION ON THE FACE OF THIS WARRANTY. WOODS MAKES NO OTHER WARRANTY, EXPRESS OR IMPLIED, AND WOODS SPECIFICALLY DISCLAIMS ANY IMPLIED WARRANTY OF MERCHANTABILITY AND/OR ANY IMPLIED WARRANTY OF FITNESS FOR A PARTICULAR PURPOSE.

WOODS shall not be liable for any incidental or consequential losses, damages or expenses, arising directly or indirectly from the product, whether such claim is based upon breach of contract, breach of warranty, negligence, strict liability in tort or any other legal theory. Without limiting the generality of the foregoing, Woods specifically disclaims any damages relating to (i) lost profits, business, revenues or goodwill; (ii) loss of crops; (iii) loss because of delay in harvesting; (iv) any expense or loss incurred for labor, supplies, substitute machinery or rental; or (v) any other type of damage to property or economic loss.

This Warranty is subject to any existing conditions of supply which may directly affect WOODS' ability to obtain materials or manufacture replacement parts.

No agent, representative, dealer, distributor, service person, salesperson, or employee of any company, including without limitation, WOODS, its authorized dealers, distributors, and service centers, is authorized to alter, modify, or enlarge this Warranty.

Answers to any questions regarding warranty service and locations may be obtained by contacting:

Woods Equipment Company

2606 South Illinois Route 2
Post Office Box 1000
Oregon IL 61061

800-319-6637 tel
800-399-6637 fax
www.WoodsEquipment.com

WOODS®

ALITEC™
BMP®
CENTRAL FABRICATORS®
GANNON®
GILL®
WAIN-ROY®
WOODS®

PART NO.
MCPLFA

**Woods Equipment
Company**

2606 South Illinois Route 2
Post Office Box 1000
Oregon, Illinois 61061

800-319-6637 tel
800-399-6637 fax
www.WoodsEquipment.com

WOODS®