

Technical sheet :

MH 25 3B - FT4



Technical characteristics			Metric
1.1	Manufacturer		Manitou
1.2	Model Name		MH 25 3B - FT4
1.3	Power source		Diesel
1.4	Operator type		Seated
1.5	Max. capacity	Q	2500 kg
1.6	Load centre of gravity	c	500 mm
1.8	Load distance, centre of drive axle to fork	x	625 mm
1.9	Wheelbase	y	1800 mm
Weight			
2.1	Service weight		4260 kg
2.2	Weight on front axle (laden) / rear axle (laden)		5812 kg / 948 kg
2.3	Weight on front axle (Unladen) / rear axle (Unladen)		1750 kg / 2510 kg
Wheels			
3.1	Tyres type		Inflatable
3.2	Dimensions of front wheels		280/80 R20 XMCL27,10 - 12 IC 30 14PR
3.3	Dimensions of rear wheels		27,10 - 12 IC 30 14PR
3.5	Number of front wheels / rear wheels		2 / 2
3.5.2	Number of drive wheels		4
3.6	Front wheel gauge	b10	1160 mm
3.7	Rear wheel gauge	b11	1164 mm
Dimensions			
4.1	Tilt of Mast Forward (deg) / Backward (deg)	α / β	10 / 12
4.7	Height of overhead guard (cabin)	h6	2105 mm
4.8	Seat height/stand height	h7	1025 mm
4.12	Height of towing bar (coupling height)	h10	310 mm
4.19	Overall length	l1	4045 mm
4.20	Length to face of forks	l2	2945 mm
4.21	Overall width	b1	1450 mm
4.22	Forks section / width / length	s / e / l	40 mm x 100 mm / 1100 mm
4.23	Fork carriage ISO 2328 (class/form) A/B		FEM 2A
4.24	Fork carriage width	b3	1260 mm
4.31	Ground clearance below mast	m1	260 mm
4.32	Ground clearance at centre of wheelbase	m2	260 mm
4.33	Aisle Width for pallets 1000 x 1200 crossways	Ast	5090 mm
4.34	Aisle width for 800 x 1200 pallet lengthways	Ast	5290 mm
4.36	Internal turning radius (over tyres)	b13	1.08 m
4.35	Turning radius	Wa	3265 mm
Performances			
5.1	Travel speed (laden / unladen)		14 km/h / 14 km/h
5.2	Lifting speed (laden / unladen)		0.40 m/s / 0.50 m/s
5.3	Lowering speed (laden / unladen)		0.50 m/s / 0.40 m/s
5.5	Drawbar pull (Laden / Unladen)		3550 daN / 3550 daN
5.7	Gradeability (laden / unladen)		50 % / 48 %
5.10	Service brake		Hydraulic
Engine			
6.4	Battery		0 V
7.1	Engine brand / model		Kubota / V2403 CR TE4
7.2	Engine power according to ISO 1585		48.60 kW
7.3	Rated speed		2700 rpm
7.4	Number of cylinders / Capacity of cylinders		4 - 2434 cm ³
Miscellaneous			
8.2	Working hydraulic pressure for attachments		170 Bar
8.3	Oil flow rate for attachments		77 l/min
8.4	Measured/guaranteed mean noise level at the ear of the operator		< 104 dB(A)

Dimensional drawing

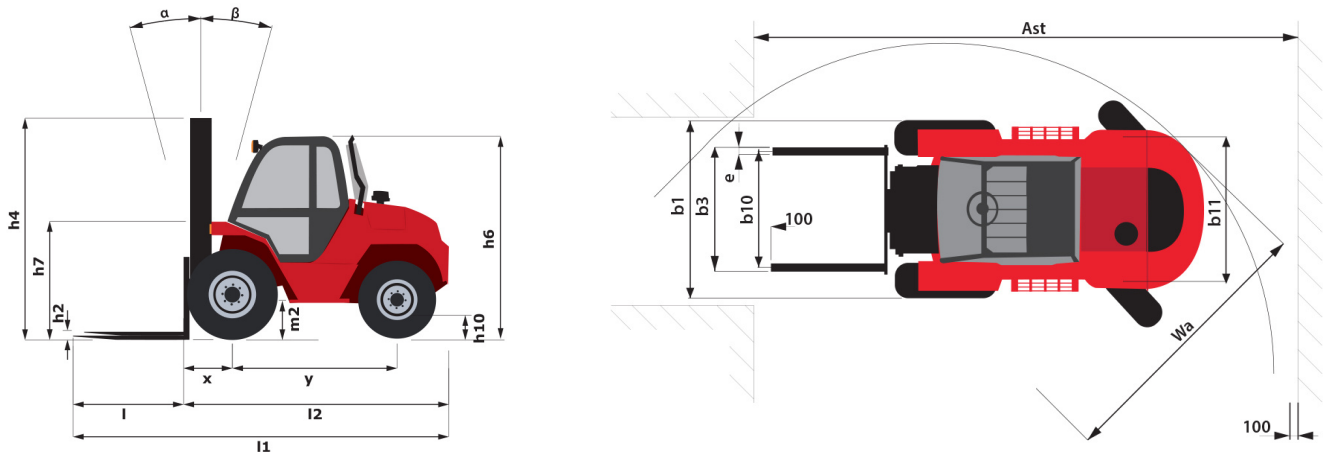

Characteristics of masts and residual capacities

Full Visibility Duplex		FVD 27	FVD 30	FVD 33	FVD 35	FVD 37	FVD 40	FVD 45	FVD 50	FVD 55	FVD 60
h2 - Free lift	mm	130	130	130	130	130	130	130	130	130	130
h1 - Height mast lowered *	mm	1995	2145	2295	2395	2555	2745	2995	3245	3495	3785
h3 - Lifting Height	mm	2700	3000	3300	3500	3700	4000	4500	5000	5500	6000
h4 - Height mast extended *	mm	3531	3831	4070	4331	4531	4831	5331	5831	6331	6831
α / β - Mast inclination (front / rear)	°	10 / 12	10 / 12	10 / 12	10 / 12	10 / 12	10 / 12	10 / 12	6 / 6	6 / 6	6 / 6
Residual capacity at max height	kg	2500	2500	2500	1900	1900	1550	1100			

Free Lift Triplex		FLT 37	FLT 40	FLT 43	FLT 47	FLT 50	FLT 55	FLT 60	FLT 65	FLT 70
h2 - Free lift	mm	1221	1321	1421	1571	1671	1831	2021	2271	2521
h1 - Height mast lowered *	mm	1945	2045	2145	2295	2395	2555	2745	2995	3245
h3 - Lifting Height	mm	3700	4000	4300	4700	5000	5500	6000	6500	7000
h4 - Height mast extended *	mm	4469	4769	5069	5469	5769	6269	6769	7269	7769
α / β - Mast inclination (front / rear)	°	10 / 12	10 / 12	10 / 12	10 / 12	6 / 6	6 / 6	6 / 6	6 / 6	6 / 6
Residual capacity at max height	kg	1900	1550	1250	1000		700			
Residual capacity without attachment (Industrial load chart)	kg						700			



Siège Social

430 rue de l'Aubinière - 44150 Ancenis Cedex - France

Tel: +33(0)2 40 09 10 11 - Fax: +33 (0)2 40 09 10 97

www.manitou.com



This brochure describes versions and configuration options for Manitou products which may be fitted with different equipment. The equipment described in this brochure may be standard, optional or not available depending on version. Manitou reserves the right to change the specifications shown and described at any time and without prior warning. The manufacturer is not liable for the specifications given. For more information, contact your Manitou dealer. Non-contractual document. Product descriptions may differ from actual products. List of specifications is not comprehensive. The logos and visual identity of the company are the property of Manitou and may not be used without authorisation. All rights reserved. The photos and diagrams contained in this brochure are provided for information only.

MANITOU BF SA - Limited company with board of directors - Share capital: 39,668,399 euros - 857 802 508 RCS Nantes