

**FELLA RAMOS** Disc mowers



**FELLA**

**RAMOS**  
Disc mowers

Harvesting energy.





A worried glance at the sky.  
Black clouds are drawing in.  
The clock is ticking.  
It will be pouring in less than an hour.  
The pleasant, sunny days are gone.  
And the work is done.  
For the harvest is already saved.



We at FELLA understand: There's a very small window for harvesting. And everything has to be just right, everything has to run like clockwork. No field is too large for our mowers, no meadow too undulating and no task too tough.

Our wide range of machines allow us to play a part in these crucial days of the year. We're proud of this. For your history is our history.



GREEN FORAGE EXPERTISE FROM FRANCONIA  
Tradition, innovation and passion –  
that's the recipe for success held by the green  
forage centre of excellence in Feucht.

# Many challenges, one solution.

Optimum cutting results with robust construction and large working widths:  
The FELLA disc mowers represent cost-effectiveness, efficiency and the best  
results when harvesting forage.

FELLA helps you achieve high-quality forage.  
Harvesting energy with FELLA.

## RAMOS front-mounted mowers

### ALPINE ..... Page 20

- ▶ Specially developed for use on alpine terrain
- ▶ Swinging hitch attachment
- ▶ Mowing on sloping terrain without loss of forage
- ▶ Working widths of 2.05 m and 2.50 m



### OSCILLATING LINKAGE ..... Page 22

- ▶ The all-rounders of the front-mounted mowers
- ▶ Large pivot travel
- ▶ Compact direct attachment with two headstock variants
- ▶ Working width of 3.10 m

**NEW**



### HEADSTOCK WITH TRAILING LINKAGE ..... Page 26

- ▶ Perfect for operating in mower combinations
- ▶ Lateral movement for harvesting without losses
- ▶ Optimum ground contour scanning
- ▶ Working widths of 3.10–3.60 m



## RAMOS mower combinations

### WITHOUT ISOBUS ..... Page 44

- ▶ Perfect for use on large farms and for contractors
- ▶ Powerful alternatives to self-propelled machines
- ▶ Extremely low-drag and cost-effective
- ▶ Working widths 8.30 m - 9.60 m

**NEW**



### WITH ISOBUS ..... Page 50

- ▶ Low-lying conveyor belt with lateral movement and speed setting
- ▶ Full automation of work processes
- ▶ Working width of 9.30 m

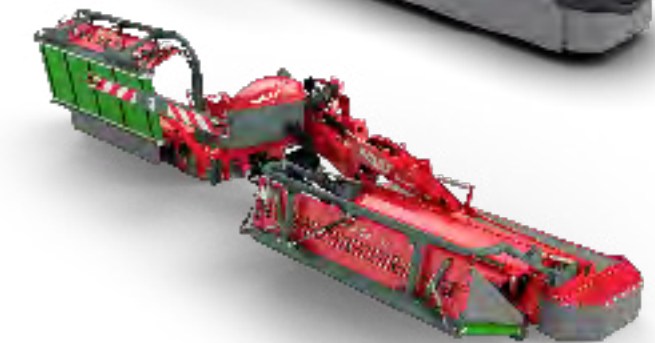

## RAMOS rear-mounted mowers

### SIDE ATTACHMENT FOR SMALLER TRACTORS ..... Page 32

- ▶ With or without inner skid
- ▶ Spring relief as standard
- ▶ Working widths of 1.66–2.82 m

### SIDE ATTACHMENT FOR THE MEDIUM POWER CLASS ..... Page 34

- ▶ Controlled kinematic lifting mechanisms
- ▶ Ease of handling
- ▶ Working widths of 2.05–3.50 m

### MIDDLE ATTACHMENT ..... Page 36

- ▶ Efficient rear-mounted mowers with and without conditioner
- ▶ Floating cut with the TurboLift cutter bar suspension system
- ▶ Very user friendly
- ▶ Working widths of 2.60–4.50 m



## RAMOS trailed mowers

### TRANSPORT CHASSIS ..... Page 56

- ▶ Centrally pivoted drawbar
- ▶ User-friendly and flexible
- ▶ Working width of 3.00 m



**AN EXACT CUT EVEN UNDER DIFFICULT CONDITIONS**

Thanks to the extremely flat cutter bar with mower discs which run in pairs, a deeper, more uniform cut is possible. With elliptical discs and robust conveyor drums, it is possible to achieve a clean cutting pattern and good forage throughput even on difficult terrain.



**VERY LOW RISK OF WEAR**

The cutter bar is bolted in place and easy to repair, with all components mounted in the base plate and bolted cover plate. The standard stone guard and large, hardened skids extend the service life.



# RAMOS spur gear drive

Low weight – highly efficient.

FELLA mowers with a spur gear drive are impressive thanks to their lightweight design and ease of handling. They are simple to attach and, because the working position can be hydraulically switched over to the transport position from the tractor seat, they are ready for use extremely quickly. Working widths of more than 3.0 m can be achieved and yield can be maximised, even with smaller tractors.



**DRIVE PROTECTED**

Clamping/shear pins in the bearing flange of each mower disc protect the drive if an obstruction is encountered when driving.

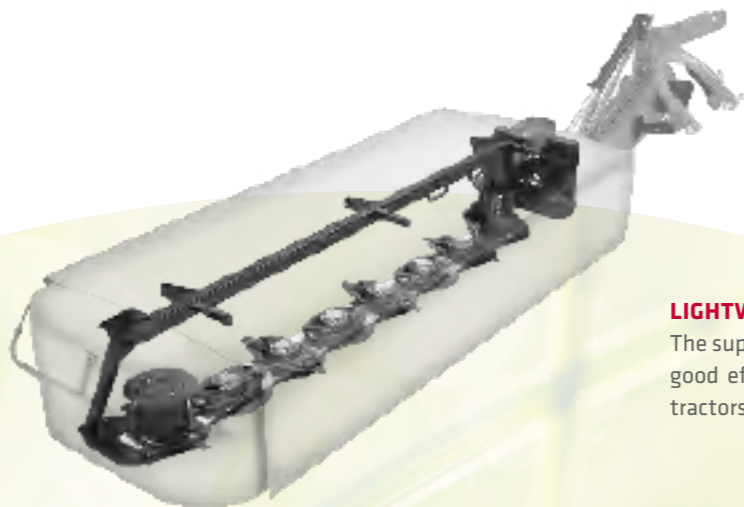

**LIGHTWEIGHT AND ROBUST**

The support frame is very lightweight but still robust and enables a very good effort (hp) to yield (ground coverage) ratio, especially for small tractors.

**RELIABLY DRIVEN**

The elastic drive, which uses a large V-belt and flanged belt pulleys, continually transfers the power reliably by means of an automatic tensioner and protects the mower components against overloading.

**LOAD RELIEF AS STANDARD**

The mechanical spring relief has a very quick response rate when working and ensures extremely good ground contour following of the cutter bar, protection of the sward and, therefore, neat and high-quality forage.



# RAMOS compact angular gear

Low power demand – huge area output.

FELLA mowers with compact angular gears are designed to provide maximum performance while remaining cost-effective in all regions and under all harvesting conditions. The design of the mower units features an impressive mix of stability and flexibility. They have particularly low power loss thanks to their special drive system, and they feature high ground coverage and a low power demand.



## PERFECT CUTTING PATTERN

The large mower disc overcut is positioned well towards the front of the mower discs and provides an ideal cutting action. To achieve this, FELLA mowers use large mower discs, which raise forage thanks to their special shape – an important aspect, particularly for heavy material lying on the ground. A further advantage of the FELLA large discs is their excellent conveying effect. This guarantees that forage is deposited ideally and loss of forage is kept to a minimum.



## HIGHEST-QUALITY FORAGE

The streamlined design with profiled base and hardened skids guarantees maximum forage quality. This enables the soil to be cleanly separated from the forage and to flow away under the cutter bar, even during field forage harvesting in poor conditions or on wetlands. The raw ash content in forage is reduced to a minimum and the sward is protected.



## MAXIMUM LONG-TERM PERFORMANCE

The indirect drive, which uses a large-dimensioned hexagonal shaft and the robust angle drive, results in uniform power output across all mower discs and the smoothing of torque peaks. The benefit of this is that the wear and load on all components within the power train is reduced, providing a longer service life. If the mower becomes blocked, the predetermined shear point in the hexagonal shaft interrupts the flow of power between the tractor and the cutter bar – protecting the drive components.



## THE BACKBONE OF ANY MOWER

The cutter bar is supported and guided by the support frame. This is manufactured from high-quality, warp-resistant steel and is designed for extremely heavy loads. The FELLA design is particularly characterised by sturdiness and durability.



## EASY-TO-ASSEMBLE CUTTER BAR DESIGN FOR HIGHER LEVELS OF COST-EFFECTIVENESS

Thanks to the bolted construction of the cutter bar and gearbox components, the assembly and replacement of individual parts is extremely user-friendly. In addition, the cutter bar requires very little maintenance thanks to its lifetime oil filling and straightforward lubrication.

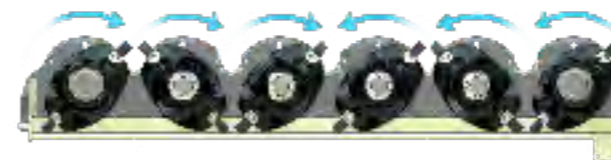

Axial running



Paired running

## FLEXIBLE DIRECTION OF ROTATION

Because of the bolted compact angular gearbox, you can specifically adapt the direction of rotation of the individual mower discs to your needs. The mower discs are converted from axial running to paired running by simply switching over two angle drives – all without any additional components.

# driveGUARD®

URNS THINGS AROUND IN EMERGENCIES.



The patented FELLA driveGUARD® provides premium overload protection. It reliably protects the mower and the mower gearbox against damage in the case of foreign objects in the crop flow.

The driveGUARD® overload disc is connected to the power train and the mower disc. If the mower disc is jammed by a foreign object, driveGUARD® shears off at defined breaking points. The connection is interrupted and the mower disc turns freely – as a result, no more forces act on the power train. This prevents damage. The key aspect here is that only the driveGUARD® overload disc must be replaced; this is mounted so that it is easily accessible outside the cutter bar – which is both extremely cost-effective and simple.

- ▶ **Cost-effective safety**
- ▶ **Protects the entire mower drive**
- ▶ **Simple, fast repairs directly on the field**
- ▶ **No long downtimes**
- ▶ **The cutter bar does not need to be opened to perform a repair**
- ▶ **Mower disc remains attached to the cutter bar at all times**
  
- ▶ **Additionally: driveGUARD® can be retrofitted easily to all mowers with a compact angular gear.**

## PRECISELY DEFINED SHEAR-OFF TORQUE

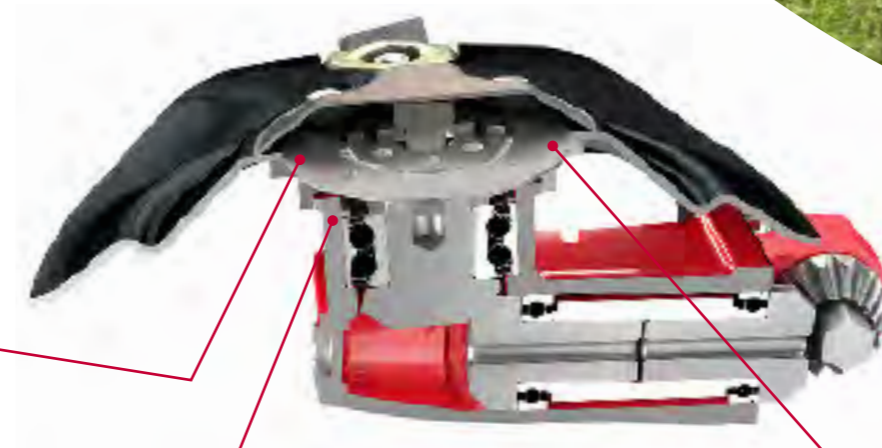
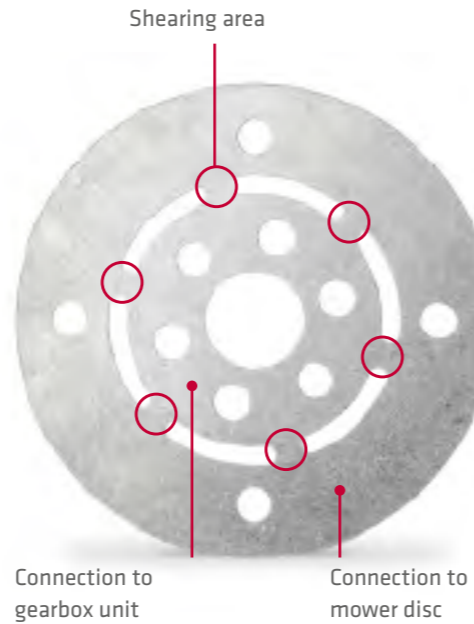



### SECURELY CONNECTED

The mower disc itself is always screw-fitted with the outer ring of the profile flange. Loss of the mower disc is safely prevented.

### INTELLIGENT ATTACHMENT

Because driveGUARD® is positioned outside the cutter bar, it is not necessary to open the cutter bar in order to carry out repairs and the oil supply is not contaminated.

-  ▶ Repairs can be carried out directly on the field in minutes.
-  ▶ Only the driveGUARD® disc needs to be replaced – **extremely cost-effective.**



## Our technology highlights

Make all the difference.



Foreign object in crop flow



Mower disc is jammed



Overload element shears off – mower disc turns freely – drive is protected

# Our technology highlights

Make all the difference.



## TurboLift

FREE-FLOATING CUTTING.



The TurboLift cutter bar suspension system from FELLA guarantees continual optimum contact pressure during the entire mowing process. Mowers with TurboLift function with a “floating cut”, protecting the sward and reducing forage contamination to a minimum. The innovative control device enables quick, easy and continuous adjustment of the contact pressure for a wide variety of operating conditions – even while driving. This provides an enormous advantage in terms of time and quality, particularly when passing over wet areas. The system is automatically calibrated for any headland. In addition, the frame structure and the skids carry less of a load and fuel consumption drops.

- ▶ Continual adjustment of contact pressure
- ▶ Free-floating cutting
- ▶ Complete control from the tractor seat – even while driving
- ▶ Sward protection – very low level of forage contamination
- ▶ Reduced fuel consumption

1 TurboLift – the hydropneumatic cutter bar suspension system can easily be controlled from the tractor seat. Constant contact pressure with infinitely variable adjustment, can also be adjusted while driving

2 “Floating cut” for protecting the sward, improved forage quality and little stress on the structure

3 The optimal contact pressure reduces fuel consumption.

4 Suspension system for the parking position, available at the press of a button. Optimal pressure is automatically produced when attaching.



## ComfortChange

STAYS SHARP - WITHOUT A BREAK.



The FELLA ComfortChange quick blade change system enables you to change the blades quickly and easily, when required. The blade key is all you need to change the blades. It can be secured so that you have both hands free. With ComfortChange, the blade is automatically locked in place and reliably secured. ComfortChange reduces the usual maintenance times considerably. This saves you both time and money.

- ▶ Straightforward blade change
- ▶ No tools required



### SAFETYSWING

approx. 20° to the rear, approx. 620 mm upwards



### EASYSWING

approx. 9° to the rear, approx. 400 mm upwards

## SafetySwing/EasySwing

SWINGING INTO ACTION.



The FELLA impact guards provides optimum safety on any field and reliably protects your machine from damage caused by hitting obstructions. If the mower encounters an obstacle, it will fold back and away and then automatically return to its original position under its own weight.

Special features of the SafetySwing:

Each mower unit is protected separately and can therefore separately swing out of the way. The pivot point of the mower unit is positioned exactly in the centre of the three-point headstock and therefore guarantees the maximum possible leverage. As a result, the mechanism is activated even if you hit an obstacle with one of the inner mower discs.

- ▶ Secures every mower unit when an obstacle is hit
- ▶ Independently realigns itself to the working position





# The FELLA conditioner principle

The quicker way to better forage.

## Why choose a conditioner?

**GUARANTEEING YOUR HIGH-QUALITY FORAGE.**

The mower-conditioner combination shortens the natural fermentation process of the mowed forage by hours. The wax layer on the forage is rubbed off and a loose, lightly packed swath is deposited. Moisture loss is accelerated through intensive air circulation. This not only has a positive effect on your costs but also on the quality of your forage, because it reduces the disintegration losses and forage contamination to a minimum. In unpredictable weather conditions in particular, this gives you a substantial time advantage – the quicker, safer way to your high-quality forage.

- ▶ **Standard equipment for many mowers, can be retrofitted to some other models**
- ▶ **Shortened fermentation process**
- ▶ **Disintegration losses and forage contamination are reduced to a minimum**
- ▶ **Decisive advantage in adverse weather conditions**
- ▶ **Lower costs**
- ▶ **Higher quality of forage**

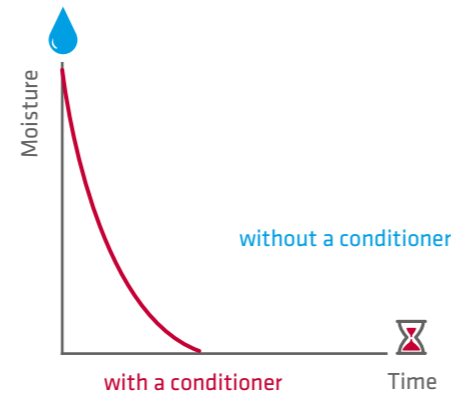

## Tine-rotor conditioner

**ONE WAVELENGTH AHEAD.**

The spring tine rotor and the multi-position adjustable conditioning comb produce a wavy forage structure which is permeable to air, the result of a number of interacting tools which open the top layer of the leaves, thus facilitating the drainage of water.



## Roller conditioner

**HAS AN IMPORTANT ROLE.**

With two robust interlocking rubber profile elements for intensive but gentle preparation of legumes or other leafy forage. The hard stalks are squeezed through the rubber rolls and the delicate, nutrient-rich leaves are conserved.



A spring-loaded foreign body protection is fitted as standard in the conditioner.

The conditioner is driven using universal joints and is secured against overload using a shear bolt – a simple, but reliable drive concept.



The contact pressure of the rubber profile elements can be variably adjusted to various forage and weather conditions.

If they are worn or damaged, the rubber elements on the shaft can be individually replaced.

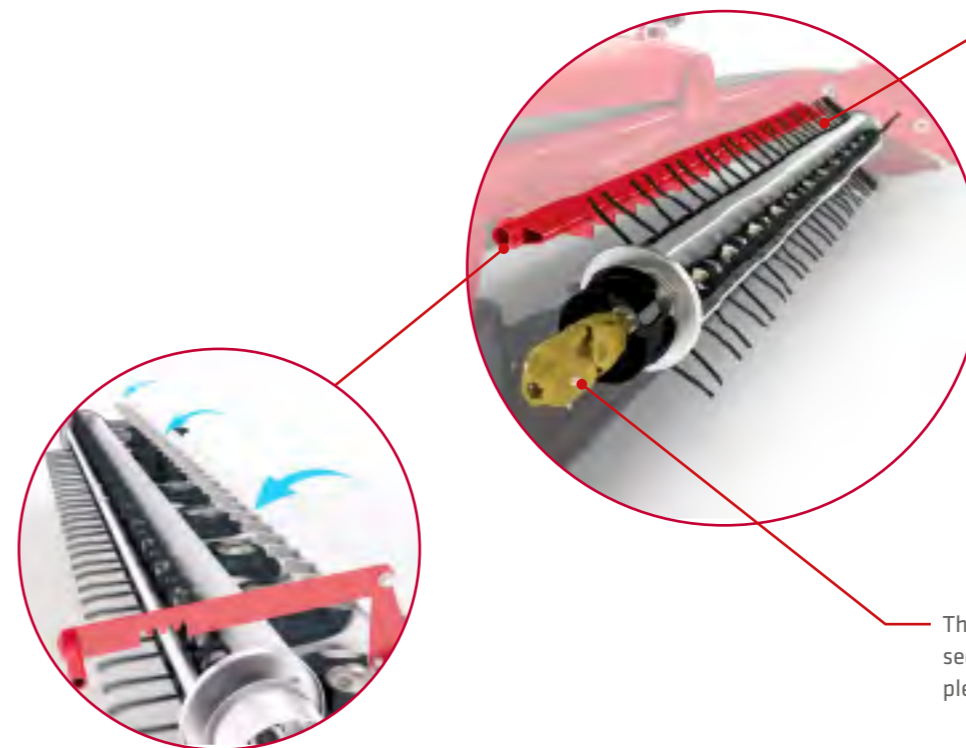

The super C flexible tines are fitted as standard with loss protection and they are extremely resistant to foreign objects in the forage.

The conditioner is driven using universal joints and is secured against overload using a shear bolt – a simple, but reliable drive concept.

Due to the preparation intensity, which can be easily adjusted using a counter-comb, a costly adjustment to the speed using a separate gearbox is not necessary. This reduces the weight and maintenance effort and therefore saves you money.

# RAMOS FRONT-MOUNTED MOWERS



**Always one cut ahead.**

# Front-mounted Alpine

At home in the mountains.

- ▶ Working widths of 2,05 m, 2,50 m and 3,00 m
- ▶ Compact angular gear
- ▶ Specially developed for use on alpine terrain
- ▶ Mowing on sloping terrain without loss of forage
- ▶ Excellent track stability
- ▶ Foldable side guard for narrow-width road travel
- ▶ No hydraulic connection needed



To also meet the high demands of farmers in alpine regions, FELLA has developed the RAMOS 200 series disc mowers. These are unique with their short, compact linkage. The centre of gravity lies close to the tractor and this leads to very good track stability on sloping terrain.

## RAMOS 260 FK

### Front-mounted compact linkage

Extremely short linkage directly on the lower link of the alpine tractors

## RAMOS 260 FP

### Front-mounted oscillating linkage

Compact linkage using a Weiste triangle on standard tractors

## RAMOS 210 FK-S

Compact linkage with lateral movement for optimal mowing on sloping terrain

## SWATH FORMATION ON SLOPES

The four centrally running mower discs allow a very good, uniform swath positioning even on sloping terrain, yet still require no additional guiding equipment.

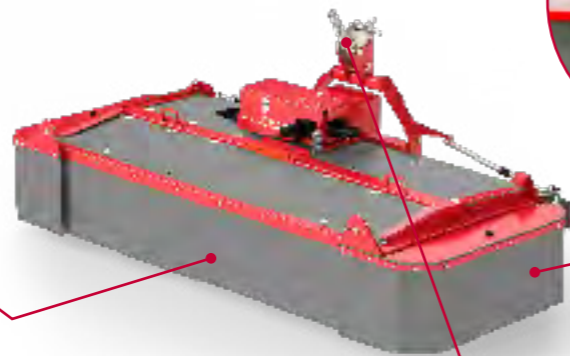

### FOLDABLE SIDE GUARD

Large width on the meadow, small width on the street



### PROTECTION AGAINST COLLISION DAMAGE

The spring-loaded impact guard on FK models protects the mower in the event of a collision with an obstacle.

## RAMOS 260 FP-S

Oscillating linkage with lateral movement for optimal mowing on sloping terrain

With the RAMOS 210 FK-S and RAMOS 260 FP-S mowers, you can also mow on the steepest alpine terrain or in the hillside line without loss of forage – thanks to the option to move the mower by up to 12 cm (RAMOS 210 FK-S) or 21 cm (RAMOS 260 FP-S) to the left or right.



### PERFECT MOWING ON SLOPING TERRAIN

1 Mechanical (FK-S) or hydraulic (FP-S) lateral movement (here: RAMOS 260 FP-S)

### ADAPTABLE

2 With a pivot travel of +/- 4.5° for the FP version and +/- 9° for the FK version, the mowers adapt to uneven ground.

### STABILITY ON SLOPES

3 Due to the short linkage, the centre of gravity lies close to the tractor.

## RAMOS 310 FP-K

Shorter front-mounted oscillating linkage

The extremely compact linkage ensures perfect ground adaptation and, since the centre of gravity is close to the tractor, even driving with light tractors is possible.



# Front-mounted Oscillating linkage

Mows in all positions.

**NEW**

- ▶ Working width of 3.10 m
- ▶ Robust spur gear drive
- ▶ Two headstock variants
- ▶ Little forage contamination thanks to good ground adaptation
- ▶ Lots of convenient features
- ▶ High level of driving safety thanks to spring-centring system
- ▶ No hydraulic connection required
- ▶ Low contact pressure due to mechanical spring relief or hydropneumatics (optional)



## RAMOS 3160 FP

### Front-mounted oscillating linkage

The new generation of oscillating linkage mower adapts to larger working width in all circumstances and is suitable for use on flat terrains and hilly regions alike. For the variants with and without conditioner, two compact headstocks configured to the specific centre of gravity are incorporated in direct attachment. A large pendulum travel, multiple coupling points and a simple counterclockwise and clockwise adjustment afford a high degree of flexibility.

## RAMOS 3160 FP-KC

### Tine-rotor conditioner

If you use a conditioner, you will achieve high-quality forage more quickly because moisture loss from plants is accelerated.

## RAMOS 3160 FP-RC

### Roller conditioners

### ALL-ROUND PROTECTION

A solid plastic strip around the guard protects against damage from minor impacts.



### HANDY AND CLEAN

The drive shaft is always ready to hand and does not end up in the dirt thanks to the bracket..



### SHORT ATTACHEMENT

The most compact attachment possible optimises mower guiding and reduces the load for the tractor and mower. For the new FP machines, there are two different direct headstocks that have been adapted to the centre of gravity of each mower with or without conditioner.



### CLEAN CUT

The robust cutter bar optimises power transmission and exhibits impressive performance properties.



### PRACTICAL

Replacement blades and quick-change blade system key always to hand and within easy reach on the left-hand side.



### STURDY

The folding support leg creates a secure base.

## ACCESSORIES

- ▶ Spring relief for attaching to tractors
- ▶ Hydropneumatic cutter bar suspension system (for KC-/RC-Machine)
- ▶ Stone guard for version with roller conditioner
- ▶ Hydraulic folding system for the side guard



**FOLLOWS THE GROUND CONTOURS**  
 The swinging axle mounted at the centre of gravity ensures optimal ground adaptation (+/- 7.5°), low contact pressure and a high level of driving safety.



**NEW**



**PERFECTLY BALANCED**  
 The integrated spring-centring system reliably prevents rocking even when driving quickly on roads. Positioning springs balance the cutter bar, thereby reducing the material load during transport and extending the service life.



**CONVENIENT TRANSPORT**  
 Adherence to the 3.00 m transport width thanks to folding safety equipment (with optional hydraulic operation).



**WORKS WITH EVERYTHING**  
 Three coupling points on the upper link and two on the lower link including pin rotation lock make it easier to adapt to different tractor models.

**OPEN FOR EVERYTHING**  
 The folding protective front hoods with tool-free central locking make the cutter bar easily accessible for maintenance and cleaning work.



**SIMPLY CONDITIONED**

- ▶ The tine-rotor conditioner (KC) can be adjusted without tools into four counter-comb positions to set the work intensity – depending on the prevailing operating conditions.
- ▶ The intensity of the roller conditioner (RC) is easily controlled via the spring tensioning force and the roller distance.
- ▶ The swath board can quickly be adjusted to any swath width required without the need for tools.

# Front-mounted 3D headstock with trailing linkage

Uncompromising ground adaptation.

- ▶ Working widths of 3.10 m and 3.60 m
- ▶ Robust spur gear drive
- ▶ Three-dimensional kinematics for transverse and longitudinal ground adaptation
- ▶ Automatic mower unit inclination of  $-6^\circ$  to  $+15^\circ$
- ▶ 450 mm ground clearance on the headland



## RAMOS 3160 FQ RAMOS 3670 FQ

### 3D headstock with trailing linkage

The RAMOS 3160 FQ and 3670 FQ front-mounted mowers meet the highest demands of modern farmers: The three-dimensional kinematics enable perfect ground adaptation in all directions, even at high driving speeds and in uneven terrain.

The overhead support frame – for absolute freedom of movement in all directions – and the automatic mower unit inclination in the direction of travel are the key to achieving the highest forage quality.

## RAMOS 3160 FQ-KC RAMOS 3670 FQ-KC

### Tine-rotor conditioner

If you use a conditioner, you will achieve high-quality forage more quickly because moisture loss from plants is accelerated. This gives you a decisive time advantage, particularly in unpredictable weather conditions.

## RAMOS 3160 FQ-RC RAMOS 3670 FQ-RC

### Roller conditioners

### ACCESSORIES

- ▶ Hydraulic lateral movement (20 cm each to the left and right)
- ▶ Hydraulically folding side guards for increased comfort
- ▶ Swath guide for operating without a conditioner for depositing an even narrower swath



### HANDY AND CLEAN

The drive shaft is always ready to hand and does not end up in the dirt thanks to the bracket.

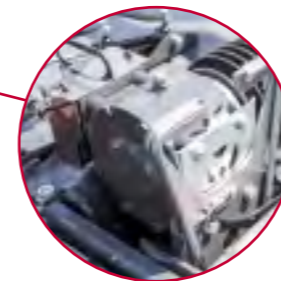

### PRACTICAL

Replacement blades and keys for quick blade changes are always handy.



### CLEAN CUT

The robust cutter bar optimises power transmission and exhibits impressive performance properties.

### REMAINS CLOSE TO THE GROUND

Thanks to the merging transverse and longitudinal movements of the three-dimensional kinematics, the mower precisely follows the ground contour. Perfect ground adaptation even at high driving speeds no longer poses a problem.



### AUTOMATIC INCLINATION

Thanks to the dynamic inclination of up to  $6^\circ$  downwards and  $15^\circ$  upwards, the entire mower unit effortlessly follows the ground contours even along dips or mounds. This reliably prevents the cutter bar from penetrating the ground – minimising the impact on the sward and mower.



**DIRECT ATTACHMENT**

The strain on both tractor and machine is relieved by the direct attachment of the mower to the front lifting gear, resulting in the centre of gravity being close to the tractor.

**SWINGING INTO ACTION**

- 1 The folding protective hoods make the cutter bar easily accessible for maintenance and cleaning work.
- 2 The side guards can be folded up to reduce the transport width – also available with hydraulic operation for even greater convenience.

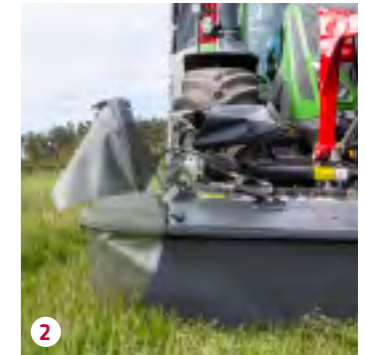

**EXCELLENT FREEDOM OF MOVEMENT**

The overhead mower towing frame ensures exceptional freedom of movement of up to +/- 13° during transverse pivot movements.



**MOWING WITHOUT LOSSES IN ALL POSITIONS**

Thanks to the hydraulic lateral movement (option), the FQ mower can be moved to the left or right as required by the situation from the comfort of the tractor seat. In bends, this stops you driving over growing crops. When drifting on a slope, counter-steering of the mower unit prevents the creation of strips.



**LARGE GROUND CLEARANCE**

The mower unit's vertical range of movement of 650 mm (200 mm downwards/450 mm upwards) ensures maximum freedom of movement, which is particularly advantageous on the headland as it makes it easy to drive over swaths lying there.



**FLOATING CUT**

The TurboLift cutter bar relief continually enables an ideal contact pressure across the full working width (see page 14).

**STRONG SUPPORT**

The parking support ensures that the FQ mower is easy to hitch to the tractor.

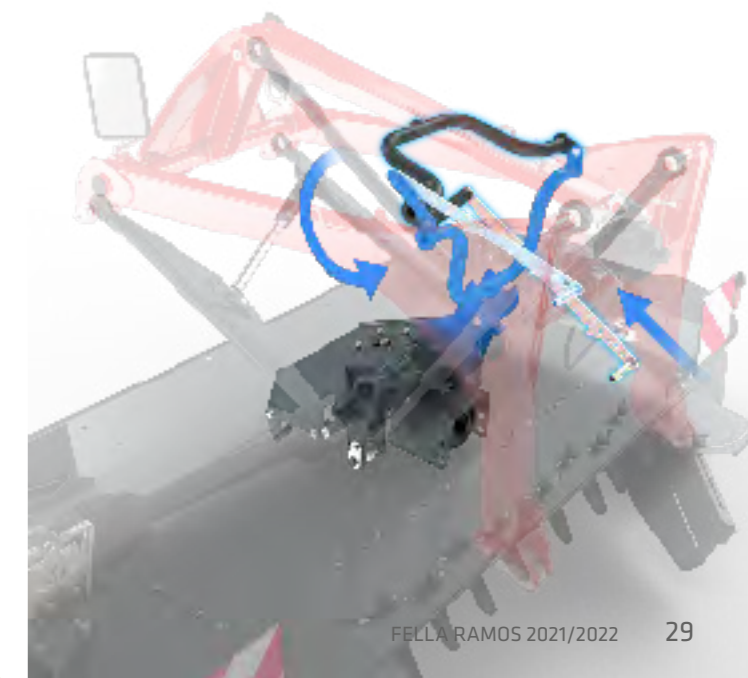

A red tractor is pulling a large, black, rear-mounted mower through a field of tall green grass. The mower has the word "FELLA" written in large white letters on its side. The tractor's hood has "RAMOS 3150 TLX" written on it. The sky is blue with scattered white clouds. A large red circular graphic is in the top right corner.

# RAMOS REAR-MOUNTED MOWERS

**Trailed behind – not left behind.**



## Three-point attachment Side attachement

Big performance for small tractors.

- ▶ Working widths of 1.66–2.82 m
- ▶ Spur gear drive with inner skid
- ▶ All drive elements run in an oil bath
- ▶ Elastic V-belt drive with automatic V-belt tension protects the mower
- ▶ Cutter bar equipped with stone guard and large hardened skid as standard for a longer service life
- ▶ Tried and tested in a variety of applications



## Three-point attachment Side attachement

Specialists in extreme conditions.

- ▶ Working widths of 2.42–2.82 m
- ▶ Spur gear drive without inner skid
- ▶ All drive elements run in an oil bath
- ▶ Elastic V-belt drive with automatic V-belt tension protects the mower
- ▶ Cutter bar equipped with stone guard and large hardened skid as standard for a longer service life
- ▶ For demanding applications
- ▶ Quick blade change system as standard



### RAMOS 168 InLine RAMOS 208 InLine RAMOS 248 InLine RAMOS 288 InLine

#### With inner skid

Thanks to their lightweight construction, FELLA disc mowers with inner skids are especially suitable for use with smaller tractors. Their adjustable lower link pins enable them to be fitted to an extremely wide variety of different tractors and tyre widths.



### RAMOS 2460 ISL RAMOS 2870 ISL

#### Without inner skid

FELLA disc mowers from the ISL series have no inner skid and have been specially developed for particularly difficult terrain. Especially in difficult hillside locations, the formation of mounds of forage is avoided using mowers without inner skid. In this way, optimum forage flow and a clean cutting pattern is achieved even under extreme harvesting conditions.

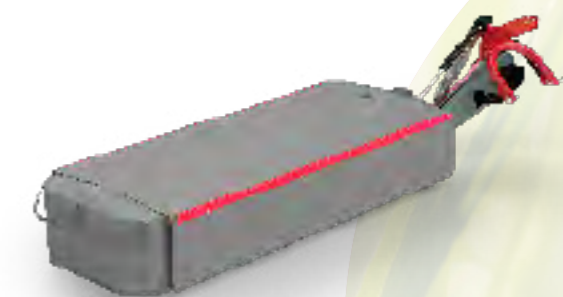

#### ACCESSORIES

- ▶ Quick blade change system for InLine models
- ▶ Swath guiding assembly
- ▶ Extra swath disc for ISL models



#### CONVENIENT MAINTENANCE

Excellent ease of access due to protective sheets that can be folded on both sides. Left: RAMOS 248 InLine; Right: RAMOS 2870 ISL



#### CONSTANT LOAD RELIEF

The standard integrated spring relief ensures low ground pressure, thereby protecting the sward.



#### PRECISE CUTTING

An extremely flat cutter bar with mower discs which run in pairs guarantees a clean cutting pattern, even for deep cuts.



#### ISL – WITHOUT INNER SKID

Drive is provided to the first mower disc directly from above, enabling trouble-free mowing on slopes.

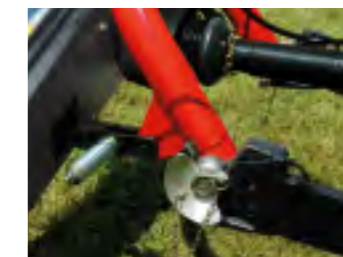

#### PROTECTION AGAINST COLLISION DAMAGE

Spring-loaded impact guard reliably protects against obstacles.



#### ADAPTABLE

Adjustable lower link pins enable adjustment for different tractors and tyre sizes.

# Three-point attachment Side attachment

Wide spread.

- ▶ Working widths of 2.05–3.50 m
- ▶ Mower for medium power class
- ▶ Compact angular gear
- ▶ Robust support frame
- ▶ Mechanical spring relief of the cutter bar
- ▶ Excellent ease of access due to protective sheets that can be folded on both sides
- ▶ Side hitch attachment – downward ground adaptation possible



Conditioners  
can be retrofitted



**RAMOS 210**  
**RAMOS 270**  
**RAMOS 320**  
**RAMOS 350**

**Rear-mounted three-point attachment, lateral**

These models are rear-mounted mowers with side attachment that are in the medium power class and are available in various versions. Typical features of the machines include the mechanical spring relief and the robust V-belt drive. An impact guard is as much part of standard equipment as the option of having track adaptation on a wide range of tractors.

## VERY USER-FRIENDLY

It could not be simpler to attach and remove the mower. The controlled kinematic lifting mechanism ensures that the cutter bar is lifted parallel to the ground at the headland. The machine is easily operated using a single-acting control unit – the position of the three-point hydraulics system remains unchanged. The sturdy mower cover opens widely on both sides allowing optimum access for cleaning and maintenance work.

## ACCESSORIES

- ▶ ComfortChange quick blade change system
- ▶ Mower disc with conveyor vane for optimal forage transport
- ▶ Additional skids for greater cutting heights and as wear protection for stony and sandy ground
- ▶ driveGUARD® retrofit kit
- ▶ Conditioner retrofit kit

**RAMOS 210 KC**  
**RAMOS 270 KC**  
**RAMOS 320 KC**

**Tine-rotor conditioner**

If you use a conditioner, you will achieve high-quality forage more quickly because moisture loss from plants is accelerated. This gives you a decisive time advantage, particularly in unpredictable weather conditions.

**RAMOS 210 RC**  
**RAMOS 270 RC**

**Roller conditioner**

## PROTECTION AGAINST COLLISION DAMAGE

The spring-loaded impact guard reliably protects against obstacles.



## PRACTICAL

Replacement blades and the quick-change blade system tool are always close at hand.



## LARGE LIFT TRAVEL

**1** The kinematic lifting mechanism prevents the sward from being pierced, thanks to the large lifting height at the headland. Downward ground adaptation is possible through interaction with the side attachment – ideal for mowing on sloping terrain.

## COMPACT AND SAFE

**2** The horizontal lock close to the tractor guarantees a high level of transport stability and ensures stability even on uneven terrain.

## OPTIMAL CROP FLOW

**3** The right- and left-hand conveyor drums ensure neat forage harvesting.



## CONVENIENT TOOL-FREE MAINTENANCE

Excellent ease of access due to protective sheets that can be folded on both sides.



## RELIABLY DRIVEN

The elastic V-belt drive with automatic V-belt tension buffers load peaks and protects the mower.

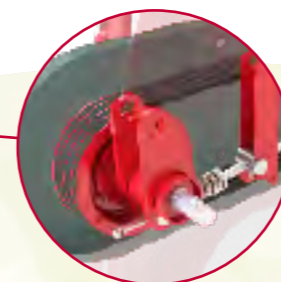

# Three-point attachment Middle attachment

## Free-floating cutting.

- ▶ Working widths of 4.00–4.50 m
- ▶ Premium mower with middle attachment
- ▶ Compact angular gear
- ▶ Perfect ground adaptation
- ▶ Continually optimal contact pressure
- ▶ High forage throughput with low raw ash content
- ▶ Gentle on the sward
- ▶ Slide track in both longitudinal and transverse direction – FELLA patent
- ▶ The mower unit does not pivot at the headland
- ▶ KENNFIXX® connector



### RAMOS 4080TL RAMOS 4590 TL

#### Rear attachment with TurboLift system

These models are specifically designed to meet the increasing demand for powerful rear-mounted mowers. Despite their large working width of up to 4.50 m, the mowers that are attached at their centre of gravity have extremely good ground adaptation.

#### FREE-FLOATING CUTTING

Thanks to its continually optimal contact pressure, the innovative TurboLift cutter bar suspension system guarantees minimal forage contamination, protection for the sward and improved cutting quality in recesses and sinks. Additionally, the machine and tractor are under less load thanks to the “floating cut”. Furthermore, a special hydraulic compensating cylinder reduces pivoting at the headland.



#### CORRECT HEIGHT

The practical working height indicator reduces set-up and take-down times out in the field.

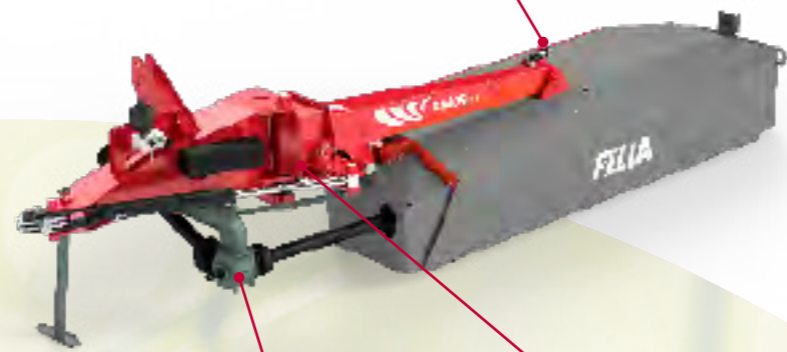

**TRANSPORT POSITION**  
RAMOS 4080 TL



#### CONVENIENT MAINTENANCE

The full-cloth guard which can be folded on both sides ensures easy access and weight reduction (RAMOS 4080 TL).



#### OPTIMUM GUIDANCE OF THE CUTTER BAR

Optimum stability and guidance of the cutter bar is guaranteed thanks to the patented slide track. As a result, the load on the lifting arm of the mower is relieved and the excellent ground adaptation is reinforced.



#### FOLDS AWAY PERFECTLY

The impact guard with pivoting gearbox ensures maximum safety against obstacles. The pivoting gearbox also provides the mower with a very wide angle of yield and ensures that the drive shaft is not damaged.



#### ACCESSORIES

- ▶ Additional skids for greater cutting heights and as wear protection for stony and sandy ground
- ▶ Set of conveyor drums for 2-swath deposit
- ▶ Mower disc with conveyor vane for optimal forage transport

# Three-point attachment Middle attachment

For optimal cutting.

- ▶ Working widths of 2.60 m–3.60 m
- ▶ Premium mower with middle attachment point and robust spur gear drive
- ▶ X-folding at the machine's centre of gravity (117°–119°, depending on working width)
- ▶ Wide working angle for optimum ground adaptation
- ▶ Many features designed for increased convenience
- ▶ Continually optimal contact pressure – perfect ground adaptation
- ▶ High forage throughput with low raw ash content
- ▶ Gentle on the sward
- ▶ The mower unit does not swing at the headland
- ▶ KENNFIXX® connector



## RAMOS 2650 TLX RAMOS 3160 TLX RAMOS 3670 TLX

Rear attachment with TurboLift system and X-folding

The new RAMOS TLX series combines TurboLift technology for optimised ground contour following with a comprehensive range of safety and convenience features. Encompassing a wide range of different models, this series has the right machine for virtually any farm. Featuring a central attachment point, the new vertical X-folding system and the SafetySwing professional impact guard, you can be sure that these machines will always be safe and secure, whether they're on the field or out on the road. A whole host of practical features have been included to make harvesting easier and to make controlling your machinery more convenient.

## RAMOS 2650 TLX-KC RAMOS 3160 TLX-KC RAMOS 3670 TLX-KC

Tine-rotor conditioner

If you use a conditioner, you will achieve high-quality forage more quickly because moisture loss from plants is accelerated. This gives you a decisive time advantage, particularly in unpredictable weather conditions.

## RAMOS 2650 TLX-RC RAMOS 3160 TLX-RC RAMOS 3670 TLX-RC

Roller conditioner

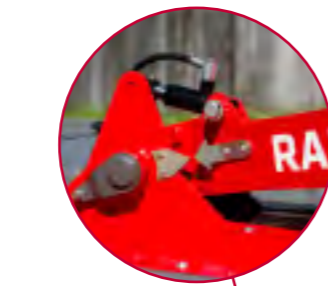

### CORRECT HEIGHT

The practical working height indicator reduces set-up and take-down times out in the field.



### CONVENIENT TRANSPORT

The transport height is maintained by means of a folding guard (with optional hydraulic operation).



### ALL-ROUND PROTECTION

A solid plastic strip around the guard protects against damage from minor impacts.

### CLEAN CUT

The robust cutter bar optimises power transmission and exhibits impressive performance properties.



### EFFECTIVE FOLDING

Hydraulic cylinders fold the RAMOS TLX mowers vertically towards the machine's centre of gravity, with a shock absorber minimising the impact when they reach their end position.

- ▶ The even distribution of weight on the lower link and axle allows for good stability and agility when the machine is being transported.
- ▶ The compact transport position means that height restrictions are not a problem.



### PRACTICAL

Replacement blades and the quick-change blade system tool are always close at hand.

### EASY TO ADJUST

The tine-rotor conditioner (KC) offers five counter-comb positions for adjusting conditioning intensity, depending on the prevailing application conditions.



### ACCESSORIES

- ▶ Hydraulically folding end cover
- ▶ Hydraulic transport locking system
- ▶ Supports for parking with mower in vertical position
- ▶ Swath guide for operating without a conditioner for depositing an even narrower swath



**EVERYTHING IN ORDER**

Practical parking supports are available as an option for RAMOS TLX mowers. These save space when parking the machinery in the transport position.



**PARKING WITHOUT PRESSURE**

The pressure-relief button on the mower's control device reduces the pressure to zero in one swift action. When you attach the mower, the system automatically restores the optimal pressure.



**SAFETYSWING - FOLDS AWAY SECURELY**

The SafetySwing impact guard, which is usually only used for large-area mowers, provides optimum safety in any field and reliably protects your machine from damage caused by striking objects. If the mower encounters an obstacle, it will fold back and up out of the way, and then automatically returns to its original position under its own weight (see p. 15).



**FLOATING CUT**

The TurboLift cutter bar suspension system ensures that the optimal contact pressure is maintained across the entire working width (see p. 14).

- ▶ Minimal forage contamination, protection for the sward and improved cutting quality in recesses and hollows
- ▶ Freely adjustable as you travel
- ▶ Automatic calibration at every headland
- ▶ Reduced fuel consumption



**GROUND ADAPTATION AND GROUND CLEARANCE**

The new boom arm design features a bend, allowing TLX mowers to achieve a wide working angle of between +28° and -18°. This optimally compensates for unevenness and height differences in the ground.

An integrated compensating cylinder also prevents rocking at the headland and allows for a large ground clearance.

# RAMOS MOWER COMBINATIONS



**Cutting power without  
compromise.**

# Mower combination

Variable light weight with high area output.

**NEW**



- ▶ Working widths of 8,30/8,60 m and 9,30/9,60 m
- ▶ Robust spur gear drive
- ▶ Low stress thanks to compact linkage
- ▶ "EasySwing" anti-collision device
- ▶ Perfect ground adaptation and gentle on the sward
- ▶ Continually optimal contact pressure
- ▶ Sophisticated design and many features designed for increased convenience
- ▶ Wide working angle for optimum ground adaptation
- ▶ The mower unit does not swing at the headland



## RAMOS 8612 TL RAMOS 9614 TL

### Mower combination with TurboLift

The new low-drag RAMOS series of mower combinations combine the benefits of a weight-optimised design with the latest FELLA drive technology, high cutting power and economic efficiency. The mowers feature the TurboLift hydropneumatic cutter bar suspension system and guarantee a continuously optimum contact pressure and a floating cut. Thanks to the efficient power transmission of the drive concept, the mower units deliver full output even at low speeds and in tractors with low horsepower, thereby saving fuel and minimising impact on crops when mowing.

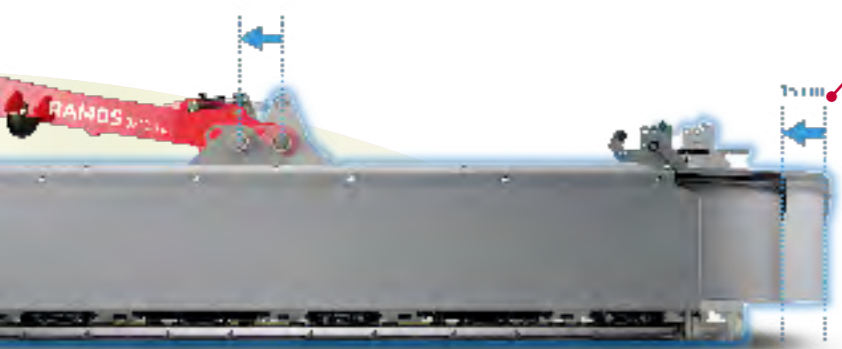

### THE PERFECT WIDTH

Because the cutter bars can be adjusted to two positions, large working widths can be achieved. It also allows for adaptation to front-mounted mowers and optimum over-cut – without having to shorten the drive shaft.

### HANDY AND CLEAN

The drive shaft is always ready to hand and does not end up in the dirt thanks to the bracket.



### NEAT AND TIDY

All connections plug neatly and safely into the hose cabinet.



### CORRECT HEIGHT

The practical working height indicator reduces set-up and take-down times out in the field.

### CLEAN CUT

The robust cutter bar optimises power transmission and exhibits impressive performance properties.



### COMPACT TRANSPORT

The mower unit support arm has a low-lying pivot point, ensuring that the mower has a low centre of gravity and a compact, low transport position.



### ACCESSORIES

- ▶ Electrohydraulic individual lift (preselect switching)
- ▶ Hydraulic foldable protective covers
- ▶ Hydraulic transport lock



**NEW**

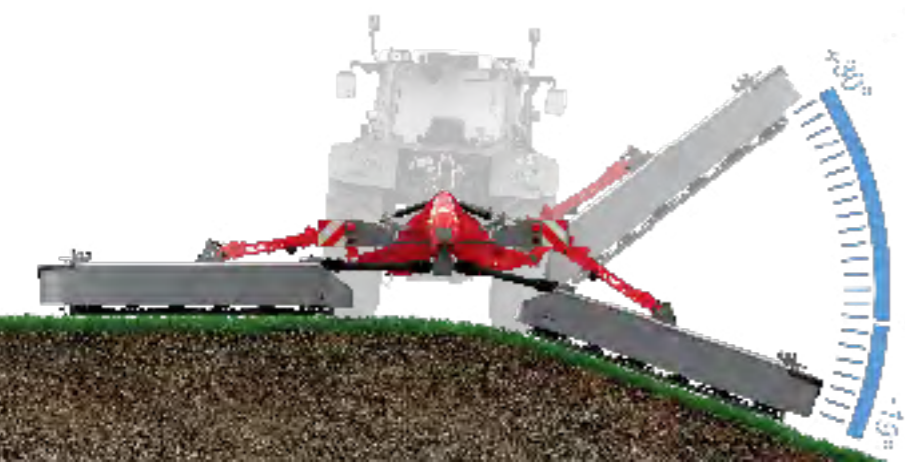
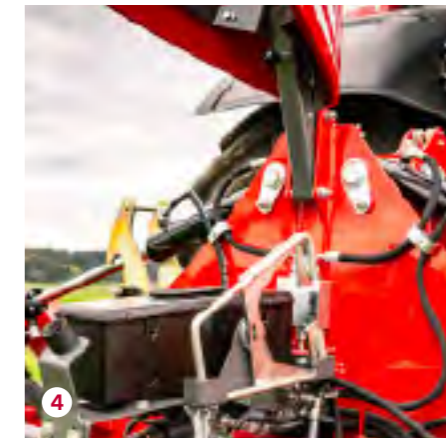
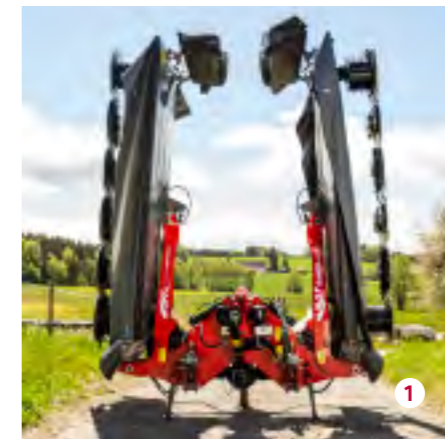

**GROUND ADAPTATION AND GROUND CLEARANCE**

The new boom arm design features a bend, allowing TLX mowers to achieve a wide working angle of between +30° and -19°. This optimally compensates for unevenness and height differences in the ground.

An integrated compensating cylinder also prevents rocking at the headland and allows for a large ground clearance.

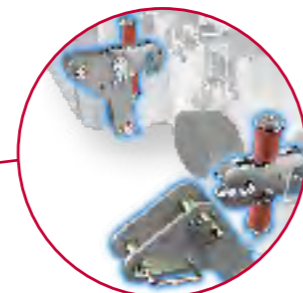

**EASYSWING – FOLDS AWAY SECURELY**

The mechanical EasySwing impact guard provides optimum safety on any field and reliably protects your machine from damage caused by hitting obstructions. If the mower encounters an obstacle, it will fold back and away and then automatically return to its original position under its own weight.

**STURDY**

1 Three stable parking supports ensure a solid footing when in the space-saving transport position. The pressure-relief button on the mower's control device reduces the pressure to zero. When you attach the mower, the system automatically restores the preset pressure.

**ALL-ROUND PROTECTION**

2 A solid plastic strip around the guard protects against damage from minor impacts. Folding protective covers ensure the transport height (hydraulic optional) is maintained

**OPEN FOR EVERYTHING**

3 The folding protective hoods with tool-free central locking make the cutter bar easily accessible for maintenance and cleaning work.

**UNDER THE COVER**

4 The quick-change blade system key and a box for blades and tools are neatly stored in the easy-to-open cover.

**FLOATING CUT**

The TurboLift cutter bar suspension system ensures that the optimal contact pressure is maintained across the entire working width (see p. 14).

- ▶ Minimal forage contamination, protection for the sward and improved cutting quality in recesses and hollows
- ▶ Freely adjustable as you travel
- ▶ Automatic calibration at every headland
- ▶ Reduced fuel consumption





# Mower combination

Easily conditioned.

- ▶ Working widths of 8.30 m and 9.30 m
- ▶ Compact angular gear
- ▶ "SafetySwing" anti-collision device
- ▶ Trailed cutter bar hitch attachment – pulling is easier than pushing
- ▶ The mower unit does not pivot at the headland



## RAMOS 911 TL-KC RAMOS 911 TL-RC RAMOS 991 TL-KC

Mower combination with TurboLift and  
tine-rotor conditioner/roller conditioner

These mower combinations combine the benefits of the FELLA compact angular cutter bar, the TurboLift system and the SafetySwing impact guard in one low-drag conditioner machine

With a conditioner, you achieve your high-quality forage more quickly because the moisture loss from the plants is accelerated. This gives you a decisive time advantage, particularly in unpredictable weather conditions.

### ACCESSORIES

- ▶ Additional skids as wear protection and for greater cutting heights
- ▶ Mower discs with conveyor vanes for optimal transport of the forage to the conditioner
- ▶ Electrohydraulic individual lift



#### CORRECT HEIGHT

The practical working height indicator reduces set-up and take-down times out in the field.

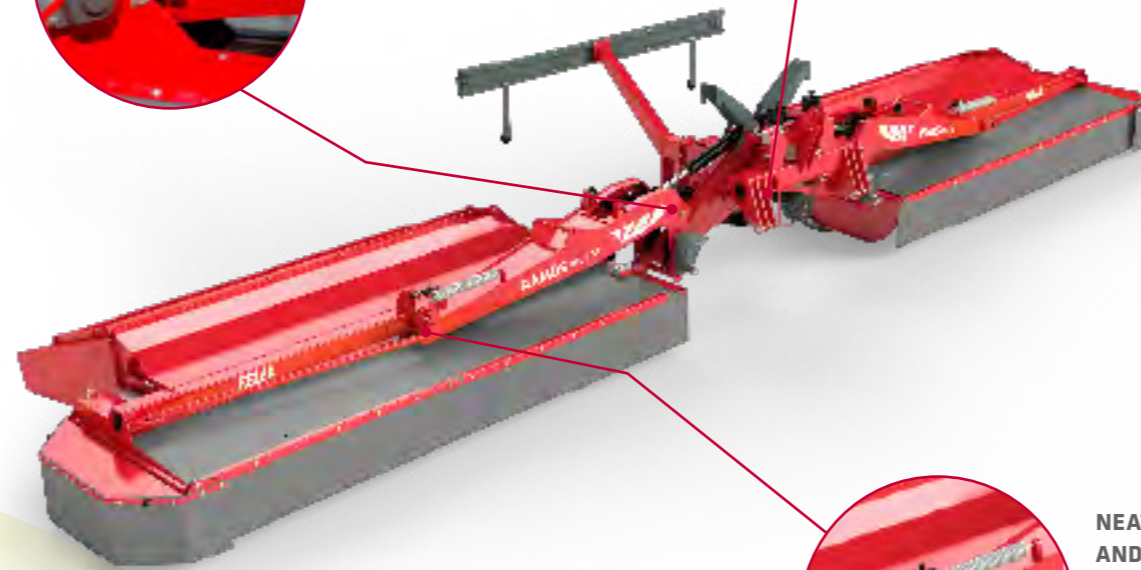

#### IN BALANCE

The mower unit mounted at the centre of gravity relieves the load on the lifting arm and ensures excellent ground adaptation and uniform contact pressure.



#### NEAT POSITIONING AND LIFTING

The centring springs on the mower units ensure positioning and lifting parallel to the ground. This protects the sward and reduces forage contamination.

#### FLOATING CUT

The TurboLift cutter bar suspension system ensures that the optimal contact pressure is maintained across the entire working width (see p. 14).

- ▶ Minimal forage contamination, protection for the sward and improved cutting quality in recesses and hollows
- ▶ Freely adjustable as you travel
- ▶ Automatic calibration at every headland
- ▶ Reduced fuel consumption

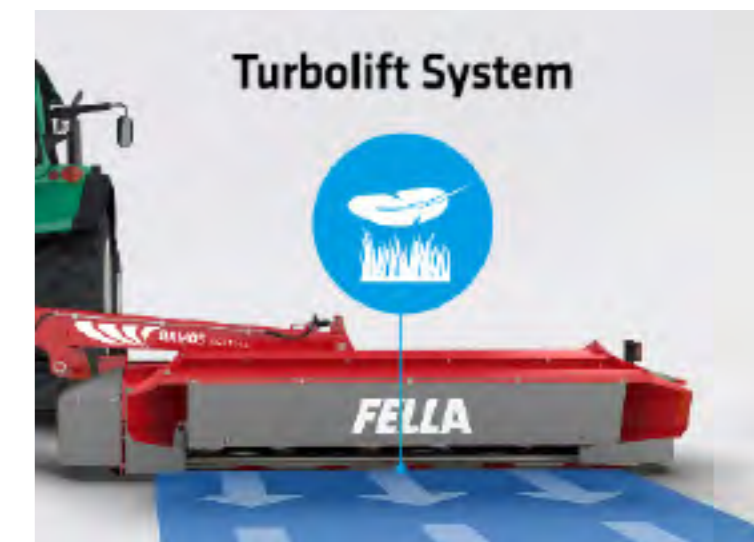

# Mower combination with ISOBUS

For the highest demands.

- ▶ Working width of 9.30 m
- ▶ Compact angular gear
- ▶ Operation of all mower functions via the ISOBUS control system
- ▶ Rotational speed monitoring
- ▶ Wide conveyor belt with integrated beMOVE hydraulic lateral movement
- ▶ Single, partial or triple deposit thanks to conveyor belts that can be raised individually
- ▶ Trailed cutter bar hitch attachment – pulling is easier than pushing
- ▶ The mower unit does not pivot at the headland
- ▶ Retrofit kit available for non-ISOBUS-compatible tractors



Active contact pressure regulation



## RAMOS 9314 TL-KCB

ISOBUS combination with TurboLift, tine-rotor conditioner and conveyor belt

Advanced machine technology coupled with a state-of-the-art ISOBUS equipment control system make the FELLA mower combinations with conveyor belts stand out from the rest. The working width of 9.30 m makes it possible to efficiently handle large volumes of forage.

The trailed hitch attachment of the mower ensures that green forage is mowed with minimal impact on the ground and that the mower is particularly efficient, making this mower combination particularly interesting in terms of cost-efficiency.



### NEAT POSITIONING AND LIFTING

The centring springs on the mower units ensure positioning and lifting parallel to the ground. This protects the sward and reduces forage contamination.

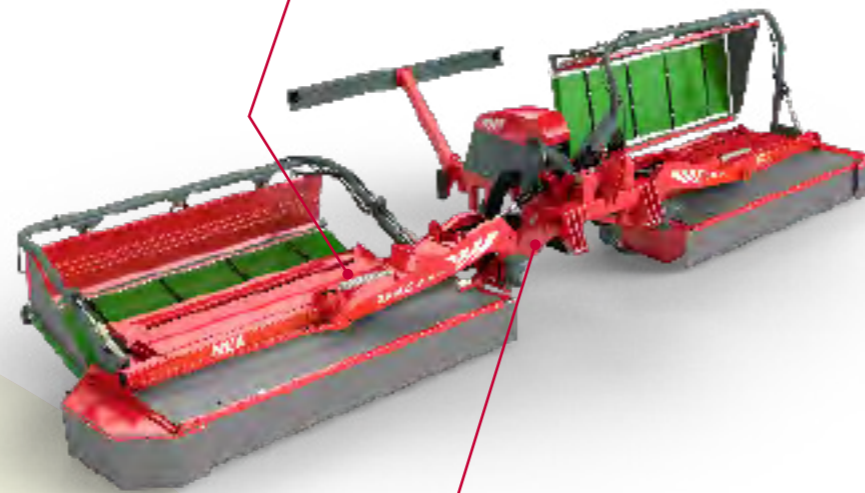

### COMPACT TRANSPORT

The mower unit support arm has a low-lying pivot point, ensuring that the mower has a low centre of gravity and a compact, low transport position.



### ISOBUS – SIMPLE AND SAFE TO OPERATE

The ISOBUS equipment control system provides the driver with a clear view of all important machine parameters on the tractor terminal at all times. This means optimum ergonomics and maximum assistance for the driver.

All mower functions, such as single lift, conveyor belt operation and slope function, can be operated using a terminal and can be programmed using the control lever or joystick if necessary.

The software can optionally be extended with the addition of Section Control for satellite-controlled lifting and lowering of mower units.



A computer-assisted automatic folding function with hydraulic transport lock allows for easy changing to the transport position, and protects the machine's power train from damage.

Sensors are used to monitor the rotational speed, which allows the driver to anticipate possible overloading of the power train early on. The benefit to you: Maximum utilised capacity and machine safety at the same time.

### ACCESSORIES

- ▶ ISOBUS tractor retrofit kit for operating and programming all mower functions via the control terminal
- ▶ Rotation speed monitoring for front-mounted mower
- ▶ Closed tank for forage transfer without losses
- ▶ Section Control for satellite-controlled lifting and lowering of mower units



**AUTOMATION WITH BENEFITS**

By combining the front-mounted mower and the rear units, it is possible to fully automate the work processes. Hour and hectare counters with integrated part-width shut-off can be used by agricultural contractors for sharing information and monitoring purposes.



**ACTIVE CONTACT PRESSURE REGULATION**

As well as the TurboLift system, the ISOBUS mowers are equipped with active contact pressure regulation, which can easily be controlled using the ISOBUS terminal. Even on extremely uneven surfaces and at differing travel speeds, the contact pressure remains constant. The "intelligent" system does not just guarantee the best possible protection for the sward; it also reduces the risk of damage and wear to the mower.



**PERFECT PREPARATION**

The transverse conveyor belts enable the highest possible level of flexibility for swath positioning. Single, partial or triple deposit – always suitable for trailing machines.

**ON THE RUNNING BELT**

Thanks to the arrangement and large dimensions of the belts, the risk of blockage is reduced to a minimum. This prevents downtime, even with large volumes of forage and over long-term use.

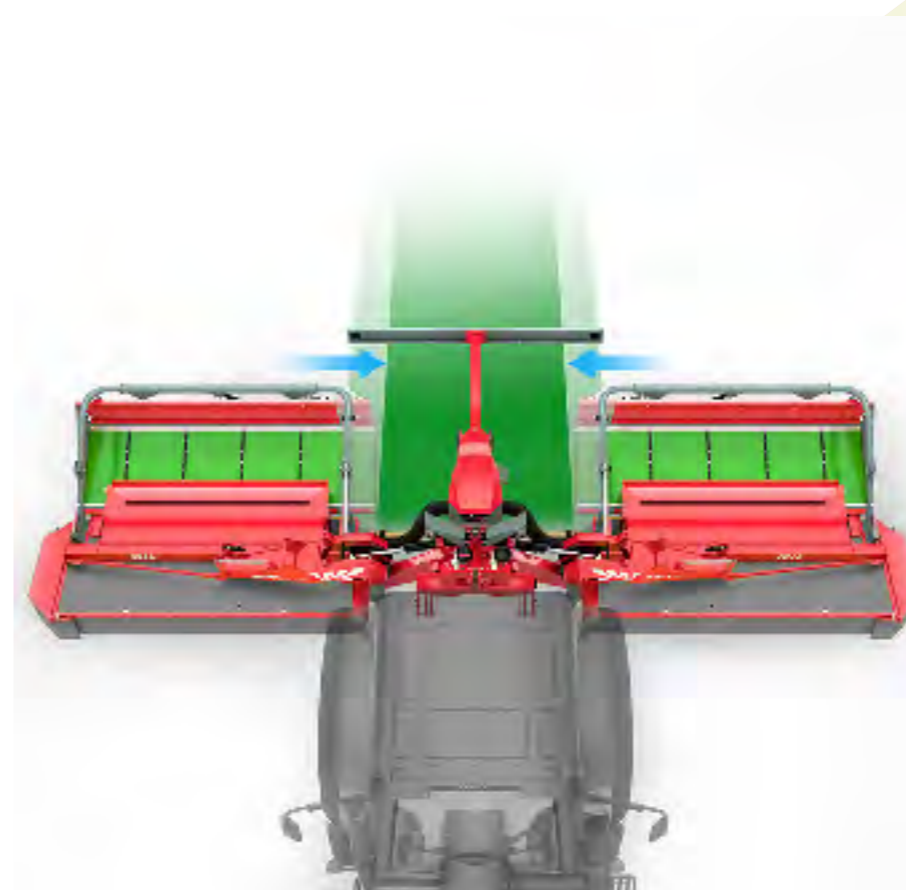

**WIDE BELT WITH INTEGRATED BEMOVE HYDRAULIC LATERAL MOVEMENT**

Our engineers have developed a particularly wide conveyor belt (940 x 2700 mm) for the FELLA mower combinations which can be used for processing larger volumes of forage without any difficulty and for continuous running at higher working speeds. Using the beMOVE hydraulic lateral movement and the conveyor belt's speed setting, it is always possible to optimally adjust the mower's swath width to the working conditions and the collecting machines following behind, all from the comfort of the driver's seat.

# RAMOS TRAILED MOWERS



**Perfectly led.**

# Trailed with transport chassis

Simple handling, superb agility.

- ▶ Working width of 3.00 m
- ▶ Compact angular gear
- ▶ Centrally pivoted drawbar
- ▶ Tine-rotor conditioner or roller conditioner
- ▶ Excellent ground adaptation
- ▶ Infinitely adjustable cutting height
- ▶ Uniform power transmission through robust pivoting gearbox – low wear and long service life
- ▶ KENNFIXX® connector
- ▶ Transport speed of up to 40 km/h (country-specific)



## RAMOS 313 TRANS-KC

Transport chassis with tine-rotor conditioner

## RAMOS 313 TRANS-RC

Transport chassis with roller conditioner

The machine is particularly characterised by its ease of handling and superb agility. The mower can be pivoted behind the tractor, both to the left and right. The sturdy pivoting gearbox means there is even power transmission in all working situations, without the drive shaft kinking. The working height can be infinitely and conveniently adjusted by a central crank. In addition, you can optimally adjust the contact pressure of the mower to your conditions. With a transport speed of up to 40 km/h (country-specific), the transport is handled quickly and simply.



### EXCELLENT GROUND ADAPTATION

The cutter bar is mounted at the outermost points on the sturdy support frame. In conjunction with the parallel adaptation of the mower unit to uneven ground, the mower is reliably prevented from piercing the sward

### PULLING IS EASIER THAN PUSHING

Lower ground pressure and fuel consumption thanks to the towing point positioned well towards the front of the suspension mounting.



### CENTRALLY PIVOTED DRAWBAR

The mower can be pivoted behind the tractor, both to the left and right.



### HIGH FLYER

The lifting height of 435 mm makes it easy to drive over swaths.



### ACCESSORIES

- ▶ ComfortChange quick blade change system
- ▶ Large-size tyres 11.5/80–15.3 for low ground pressure on surfaces that are less able to support heavy weights

# Technical data

## FRONT-MOUNTED MOWERS

RAMOS	210 FK-S	260 FK	260 FP	260 FP-S	3160 FP	3160 FP-KC	3160 FP-RC	310 FP-K
<b>Dimensions and weight</b>								
Approx. working width in m	2.05	2.50	2.50	2.50	3,10	3,10	3,10	3.00
Approx. transport width in m	2.08	2.50	2.50	2.50	2,99	2,99	2,99	3.00
Approx. swath width in m	1.10	1.35	1.35	1.35	1,80	1,20 - 2,00	1,20 - 2,00	2.00
Approx. transport height in m	-	-	-	-	-	-	-	-
Approx. transport length in m	1.18	1.29	1.21	1.21	1,65	1,74	1,74	1.25
Approx. weight in kg	373	410	474	504	710	1.015	1.045	694
<b>Power demand</b>								
Approx. power demand in kW/hp	19/26	22/30	28/38	28/38	44/60	56/75	52/70	55/75
<b>Attachment</b>								
Three-point	CAT I	CAT I	CAT II	CAT II	CAT II	CAT II	CAT II	CAT II
Two-point lower links	-	-	-	-	-	-	-	-
<b>Mower unit</b>								
Mower discs	4	4	4	4	6	6	6	6
Blades per disc	2	2	2	2	2	2	2	2
Quick blade change system/ComfortChange	□	-	-	-	■	■	■	■
Conditioner	-	-	-	-	-	KC	RC	-
Transverse conveyor belt	-	-	-	-	-	-	-	-
Hydraulic lateral movement	□*	-	-	■	-	-	-	-
<b>driveGUARD®</b>	□	□	-	-	-	-	-	■
<b>Hydraulics and PTO shaft</b>								
Required hydraulic connections	-	-	-	-	-	-	-	-
PTO rpm	540/1000	540/1000	540/1000	540/1000	1.000	1.000	1.000	1000
<b>Lighting and tyres</b>								
Electric lighting	-	-	-	-	□	□	□	□
Warning signs	-	-	-	-	□	□	□	□
Transport wheel	-	-	-	-	-	-	-	-
<b>Drive</b>								
Spur gear drive	-	-	-	-	■	■	■	-
Compact angular gear	■	■	■	■	-	-	-	■

■ Series □ Equipment variant - not available

\* mechanical as standard, hydraulic optional

<sup>1</sup> only required for optional hydraulic lateral movement

<sup>2</sup> for the "Electro-hydraulic controller" option, the number of control units is reduced to 1x load-sensing connection

### MACHINE DESIGNATIONS AND ABBREVIATIONS:

- ▶ **FK:** Front-mounted compact headstock
- ▶ **FP:** Front-mounted oscillating headstock
- ▶ **FP-K:** Front-mounted oscillating linkage, short
- ▶ **FQ:** Front-mounted 3D headstock with trailing linkage
- ▶ **TL:** TurboLift system
- ▶ **TLX:** TurboLift system + X-folding
- ▶ **Trans:** Transport chassis
- ▶ **B:** Belt
- ▶ **KC:** Tine-rotor conditioner
- ▶ **RC:** Roller-conditioner with rubber profile units
- ▶ **InLine:** Spur gear drive with inner skid
- ▶ **ISL:** Spur gear drive without inner skid



driveGUARD®



ComfortChange



TurboLift



SafetySwing/  
EasySwing



Tine-rotor conditioner



Roller conditioner

Illustrations show some of the special equipment. The right to technical revision is reserved. Some machines available in selected countries only. The images provided do not necessarily correspond to the most recent version of standard equipment.

# Technical data

## FRONT-MOUNTED MOWERS

RAMOS	3160 FQ	3160 FQ-KC	3160 FQ-RC	3670 FQ	3670 FQ-KC	3670 FQ-RC
<b>Dimensions and weight</b>						
Approx. working width in m	3.10	3.10	3.10	3.60	3.60	3.60
Approx. transport width in m	2.99	2.99	2.99	3.49	3.49	3.49
Approx. swath width in m	1.80	1.20-2.00	1.20-2.00	2.30	1.70-2.50	1.70-2.50
Approx. transport height in m	-	-	-	-	-	-
Approx. transport length in m	2.05	2.05	2.05	2.05	2.05	2.05
Approx. weight in kg	950	1238	1238	1020	1343	1373
<b>Power demand</b>						
Approx. power demand in kW/hp	44/60	56/75	52/70	52/70	67/90	63/85
<b>Attachment</b>						
Three-point	CAT II	CAT II	CAT II	CAT II	CAT II	CAT II
Two-point lower links	-	-	-	-	-	-
<b>Mower unit</b>						
Mower discs	6	6	6	7	7	7
Blades per disc	2	2	2	2	2	2
Quick blade change system/ ComfortChange	■	■	■	■	■	■
Conditioner	-	KC	RC	-	KC	RC
Transverse conveyor belt	-	-	-	-	-	-
Hydraulic lateral movement	□	□	□	□	□	□
<b>driveGUARD®</b>	-	-	-	-	-	-
<b>Hydraulics and PTO shaft</b>						
Required hydraulic connections	1 x SA	1 x SA	1 x SA	1 x SA	1 x SA	1 x SA
PTO rpm	1000	1000	1000	1000	1000	1000
<b>Lighting and tyres</b>						
Electric lighting	□	□	□	□	□	□
Warning signs	□	□	□	□	□	□
Transport wheel	-	-	-	-	-	-
<b>Drive</b>						
Spur gear drive	■	■	■	■	■	■
Compact angular gear	-	-	-	-	-	-

■ Series □ Equipment variant - not available

\* mechanical as standard, hydraulic optional

<sup>1</sup> only required for optional hydraulic lateral movement

<sup>2</sup> for the "Electro-hydraulic controller" option, the number of control units is reduced to 1 x load-sensing connection

### MACHINE DESIGNATIONS AND ABBREVIATIONS:

- ▶ **FK:** Front-mounted compact headstock
- ▶ **FP:** Front-mounted oscillating headstock
- ▶ **FP-K:** Front-mounted oscillating linkage, short
- ▶ **FQ:** Front-mounted 3D headstock with trailing linkage
- ▶ **TL:** TurboLift system
- ▶ **TLX:** TurboLift system + X-folding
- ▶ **Trans:** Transport chassis
- ▶ **B:** Belt
- ▶ **KC:** Tine-rotor conditioner
- ▶ **RC:** Roller-conditioner with rubber profile units
- ▶ **InLine:** Spur gear drive with inner skid
- ▶ **ISL:** Spur gear drive without inner skid

Illustrations show some of the special equipment. The right to technical revision is reserved. Some machines available in selected countries only. The images provided do not necessarily correspond to the most recent version of standard equipment.

# Technical data

## REAR-MOUNTED MOWERS

RAMOS	168 InLine	208 InLine	248 InLine	288 InLine	2460 ISL	2870 ISL
<b>Dimensions and weight</b>						
Approx. working width in m	1.66	2.06	2.42	2.82	2.42	2.82
Approx. transport width in m	1.73	1.73	1.73	1.73	1.80	1.80
Approx. swath width in m	0.90	1.25	1.65	2.00	1.65	2.00
Approx. transport height in m	2.47	2.85	3.23	3.61	3.30	3.70
Approx. transport length in m	1.25	1.25	1.25	1.25	1.35	1.35
Approx. weight in kg	372	407	437	475	510	550
<b>Power demand</b>						
Approx. power demand in kW/hp	22/30	30/41	37/50	44/60	37/50	44/60
<b>Attachment</b>						
Three-point	CAT I + II	CAT I + II	CAT I + II	CAT I + II	CAT I + II	CAT I + II
Two-point lower links	-	-	-	-	-	-
<b>Mower unit</b>						
Mower discs	4	5	6	7	6	7
Blades per disc	2	2	2	2	2	2
Quick blade change system/ ComfortChange	□	□	□	□	■	■
Conditioner	-	-	-	-	-	-
Transverse conveyor belt	-	-	-	-	-	-
Hydraulic lateral movement	-	-	-	-	-	-
<b>driveGUARD®</b>	-	-	-	-	-	-
<b>Hydraulics and PTO shaft</b>						
Required hydraulic connections	1 x SA	1 x SA	1 x SA	1 x SA	1 x SA	1 x SA
PTO rpm	540	540	540	540	540	540
<b>Lighting and tyres</b>						
Electric lighting	-	-	-	-	-	-
Warning signs	-	-	-	-	-	-
Transport wheel	-	-	-	-	-	-
<b>Drive</b>						
Spur gear drive	■	■	■	■	■	■
Compact angular gear	-	-	-	-	-	-

# Technical data

## REAR-MOUNTED MOWERS

RAMOS	210	270	320	350	4080 TL	4590 TL	2650 TLX	2650 TLX-KC	2650 TLX-RC	3160 TLX	3160 TLX-KC	3160 TLX-RC	3670 TLX	3670 TLX-KC	3670 TLX-RC
<b>Dimensions and weight</b>															
Approx. working width in m	2.05	2.55	3.00	3.50	4.00	4.50	2.60	2.60	2.60	3.10	3.10	3.10	3.60	3.60	3.60
Approx. transport width in m	2.13	2.13	2.13	2.13	2.30	2.30	2.20	2.20	2.20	2.50	2.50	2.50	2.80	2.80	2.80
Approx. swath width in m	1.10	1.60	1.80	2.30	3.30	3.80	1.40	0.90-1.50	0.90-1.50	1.80	1.20-2.00	1.20-2.00	2.30	1.70-2.50	1.70-2.50
Approx. transport height in m	2.47	2.95	3.43	3.91	-	-	3.17	3.17	3.17	3.58	3.58	3.58	3.99	3.99	3.99
Approx. transport length in m	1.30	1.30	1.30	1.30	5.60	6.10	1.70	2.10	2.10	1.70	2.10	2.10	1.70	2.10	2.10
Approx. weight in kg	612	630	724	798	980	1100	950	1150	1150	1050	1350	1350	1200	1500	1500
<b>Power demand</b>															
Approx. power demand in kW/hp	36/49	40/54	45/61	50/68	72/99	84/115	55/75	74/100	74/100	63/85	85/115	85/115	70/95	96/130	96/130
<b>Attachment</b>															
Three-point	CAT II	CAT II	CAT II	CAT II	CAT II + III	CAT II + III	CAT II + III	CAT II + III	CAT II + III	CAT II + III	CAT II + III	CAT II + III	CAT II + III	CAT II + III	CAT II + III
Two-point lower links	-	-	-	-	-	-	-	-	-	-	-	-	-	-	-
<b>Mower unit</b>															
Mower discs	4	5	6	7	8	9	5	5	5	6	6	6	7	7	7
Blades per disc	2	2	2	2	2	2	2	2	2	2	2	2	2	2	2
Quick blade change system/ComfortChange	□	□	□	□	■	■	■	■	■	■	■	■	■	■	■
Conditioner	□ KC/RC	□ KC/RC	□ KC	-	-	-	-	-	-	-	KC	RC	-	KC	RC
Transverse conveyor belt	-	-	-	-	-	-	-	-	-	-	-	-	-	-	-
Hydraulic lateral movement	-	-	-	-	-	-	-	-	-	-	-	-	-	-	-
driveGUARD®	□	□	□	□	■	■	-	-	-	-	-	-	-	-	-
<b>Hydraulics and PTO shaft</b>															
Required hydraulic connections	1xSA	1xSA	1xSA	1xSA	1xSA, 1xDA	1xSA, 1xDA	1xSA, 1xDA	1xSA, 1xDA	1xSA, 1xDA	1xSA, 1xDA	1xSA, 1xDA	1xSA, 1xDA	1xSA, 1xDA	1xSA, 1xDA	1xSA, 1xDA
PTO rpm	540	540	540	540	1000	1000	1000	1000	1000	1000	1000	1000	1000	1000	1000
<b>Lighting and tyres</b>															
Electric lighting	□	□	□	□	■	■	□	□	□	□	□	□	□	□	□
Warning signs	□	□	□	□	■	■	□	□	□	□	□	□	□	□	□
Transport wheel	-	-	-	-	-	-	-	-	-	-	-	-	-	-	-
<b>Drive</b>															
Spur gear drive	-	-	-	-	-	-	■	■	■	■	■	■	■	■	■
Compact angular gear	■	■	■	■	■	■	-	-	-	-	-	-	-	-	-

■ Series □ Equipment variant - not available

\* mechanical as standard, hydraulic optional

<sup>1</sup> only required for optional hydraulic lateral movement

<sup>2</sup> for the "Electro-hydraulic controller" option, the number of control units is reduced to 1x load-sensing connection

### MACHINE DESIGNATIONS AND ABBREVIATIONS:

- ▶ **FK:** Front-mounted compact headstock
- ▶ **FP:** Front-mounted oscillating headstock
- ▶ **FP-K:** Front-mounted oscillating linkage, short
- ▶ **FQ:** Front-mounted 3D headstock with trailing linkage
- ▶ **TL:** TurboLift system
- ▶ **TLX:** TurboLift system + X-folding
- ▶ **Trans:** Transport chassis
- ▶ **B:** Belt
- ▶ **KC:** Tine-rotor conditioner
- ▶ **RC:** Roller-conditioner with rubber profile units
- ▶ **InLine:** Spur gear drive with inner skid
- ▶ **ISL:** Spur gear drive without inner skid

Illustrations show some of the special equipment. The right to technical revision is reserved. Some machines available in selected countries only. The images provided do not necessarily correspond to the most recent version of standard equipment.



# Technical data

## REAR-MOUNTED MOWERS



RAMOS	8614 TL	9614 TL	911 TL-KC	911 TL-RC	991 TL-KC	9314 TL-KCB	313 Trans-KC	313 Trans-RC
<b>Dimensions and weight</b>								
Approx. working width in m	8,30/8,60	9,30/9,60	8.30	8.30	9.30	9.30	3.00	3.00
Approx. transport width in m	2,99	2,99	2.78	2.78	2.78	2.78	3.00	3.00
Approx. swath width in m	2x 1,80	2x 2,30	2x1.45-2.25	2x1.55-1.90	2x1.85-3.25	2x1.80-3.00	0.90-2.25	1.55-1.90
Approx. transport height in m	3,99	3,99	3.73	3.73	3.90	3.90	-	-
Approx. transport length in m	-	-	-	-	-	-	7.00	7.00
Approx. weight in kg	1610	1850	2410	2508	2830	3450	1945	1962
<b>Power demand</b>								
Approx. power demand in kW/hp	81/110	96/130	132/180	128/175	155/200	168/228	66/90	66/90
<b>Attachment</b>								
Three-point	CAT II	CAT II	CAT II + III	CAT II + III	CAT II + III	CAT II + III	-	-
Two-point lower links	-	-	-	-	-	-	CAT II	CAT II
<b>Mower unit</b>								
Mower discs	2x6	2x6	2x6	2x6	2x7	2x7	6	6
Blades per disc	2	2	2	2	2	2	2	2
Quick blade change system/ComfortChange	■	■	■	□	■	■	□	□
Conditioner	KC	KC	KC	RC	KC	KC	KC	RC
Transverse conveyor belt	-	-	-	-	-	■	-	-
Hydraulic lateral movement	-	-	-	-	-	■	-	-
<b>driveGUARD®</b>	-	-	■	■	■	■	■	■
<b>Hydraulics and PTO shaft</b>								
Required hydraulic connections	2xEW, 1xDW <sup>2</sup>	2xEW, 1xDW <sup>2</sup>	2xSA, 1xDA <sup>2</sup>	2xSA, 1xDA <sup>2</sup>	2xSA, 1xDA <sup>2</sup>	1xload sensing	1xSA, 1xDA	1xSA, 1xDA
PTO rpm	1.000	1.000	1000	1000	1000	1000	540/1000	540/1000
<b>Lighting and tyres</b>								
Electric lighting	■	■	■	■	■	■	■	■
Warning signs	■	■	■	■	■	■	■	■
Transport wheel	-	-	-	-	-	-	10.0/75-15.3	10.0/75-15.3
<b>Drive</b>								
Spur gear drive	■	■	-	-	-	-	-	-
Compact angular gear	-	-	■	■	■	■	■	■

■ Series □ Equipment variant - not available

\* mechanical as standard, hydraulic optional

<sup>1</sup> only required for optional hydraulic lateral movement

<sup>2</sup> for the "Electro-hydraulic controller" option, the number of control units is reduced to 1x load-sensing connection

### MACHINE DESIGNATIONS AND ABBREVIATIONS:

- ▶ **FK:** Front-mounted compact headstock
- ▶ **FP:** Front-mounted oscillating headstock
- ▶ **FP-K:** Front-mounted oscillating linkage, short
- ▶ **FQ:** Front-mounted 3D headstock with trailing linkage
- ▶ **TL:** TurboLift system
- ▶ **TLX:** TurboLift system + X-folding
- ▶ **Trans:** Transport chassis
- ▶ **B:** Belt
- ▶ **KC:** Tine-rotor conditioner
- ▶ **RC:** Roller-conditioner with rubber profile units
- ▶ **InLine:** Spur gear drive with inner skid
- ▶ **ISL:** Spur gear drive without inner skid

Illustrations show some of the special equipment. The right to technical revision is reserved. Some machines available in selected countries only. The images provided do not necessarily correspond to the most recent version of standard equipment.





**AGCO International GmbH**  
Victor von Bruns - Strasse 17  
CH-8212 Neuhausen am Rheinfall

**Your FELLA quality partner**