

Technical sheet :

# **AETJ 43**

---



Capacities		Metric
Working height	h21	15 m
Platform height	h7	13 m
Max. outreach	r1	7.60 m
Overhang	h31	7 m
Pendular arm rotation (top / bottom)		+65 ° / -65 °
Platform capacity	Q	227 kg
Turret rotation		355 °
Platform rotation (right / left)		66 ° / 59 °
Number of people (inside / outside)		2 / 2
Weight and dimensions		
Platform weight*		7370 kg
Platform dimensions (length x width)	lp / ep	1.20 m x 0.92 m
Overall width	b1	1.50 m
Overall length	l1	6.05 m
Overall height	h17	1.97 m
Overall length (stowed)	l9	4.40 m
Overall height (stowed)	h18	2.08 m
Floor height (access)	h20	0.40 m
Jib length	l13	1.26 m
Counterweight offset (turret at 90°)	a7	0.12 m
Internal turning radius (over tyres)	b13	1.87 m
External turning radius	Wa3	3.96 m
Tailswing		0.12 m
Ground clearance at centre of wheelbase	m2	0.14 m
Wheelbase	y	2 m
Performances		
Drive speed - stowed		5 km/h
Drive speed - raised		0.60 km/h
Gradeability		22 %
Permissible leveling		3 °
Wheels		
Tyres type		Solid non-marking tires
Dimensions of front wheels / rear wheels		0,6X0,19m - 0,6X0,19m
Drive wheels (front / rear)		0 / 2
Steering wheels (front / rear)		2 / 0
Braking wheels (front / rear)		0 / 2
Engine/Battery		
Electric engine power rating		2 x 4.50 kW
Electric Pump		3.70 kW
Battery / Batteries capacity		48 V / 240 Ah
Integrated charger (V / A)		48 V / 30 mA
Miscellaneous		
Number of cycles with STD Battery (HIRD)		44
Ground Pressure		13.50 daN/cm <sup>2</sup>
Hydraulic Pressure		210 Bar
Hydraulic tank capacity		15 l
Vibration on hands/arms		< 2.50 m/s <sup>2</sup>
Standards compliance		
This machine is in compliance with:		ANSI A92.20-2018 CSA B354.6 ICES-002-Issue 6 Standard Canadian EMC

# Dimensional drawing

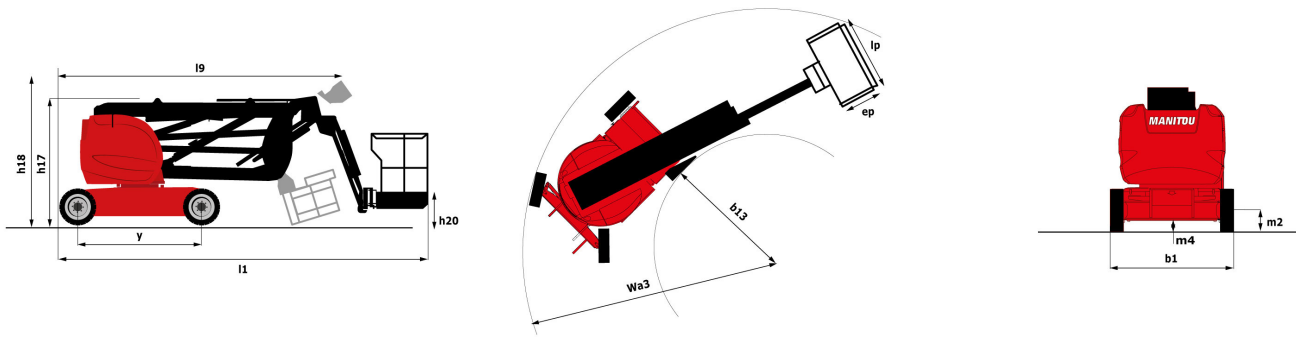

# Equipment

## Standard

110 or 230V plug with differential circuit breaker

Audible alarm and illuminated indicator lamp (leveling, overload, lowering)

Battery charge indicator lamp

CAN bus technology

Drive safety orientation system

Electric predisposition on the top of the boom

Emergency stop button in platform and on frame

Hom in the platform

Hour meter

Integrated diagnostic assistance

Manual emergency lowering

Multi-voltage integrated charger

Negative-type braking on rear wheels

Non-marking rubber tyres

Platform access gate

Proportional controls

Tool box in platform

Traction battery

Travel possible at maximum height

## Optional

Air predisposition

Beep on every movement

Beep upon travel

Biodegradable oil

Cold weather kit

Easy Manager

Extreme cold oil

Flashing Light

Highly capacity battery

Protective cover for control panel

SMS : Safe Man System

Working headlight in platform

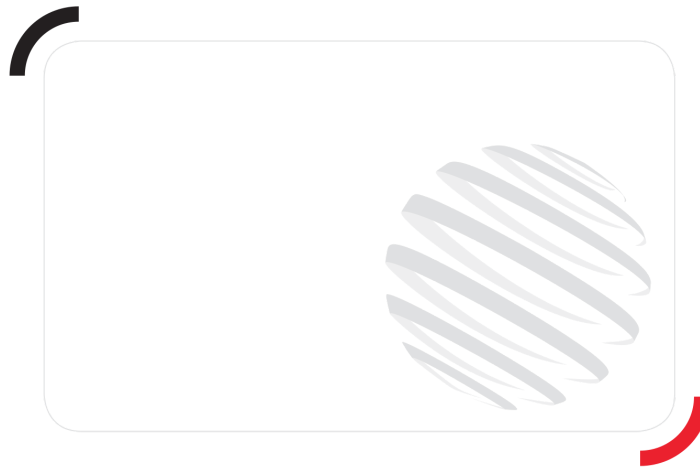

Siège Social

430 rue de l'Aubinière - 44150 Ancenis Cedex - France

Tel: +33(0)2 40 09 10 11 - Fax: +33 (0)2 40 09 10 97

[www.manitou.com](http://www.manitou.com)



This brochure describes versions and configuration options for Manitou products which may be fitted with different equipment. The equipment described in this brochure may be standard, optional or not available depending on version. Manitou reserves the right to change the specifications shown and described at any time and without prior warning. The manufacturer is not liable for the specifications given. For more information, contact your Manitou dealer. Non-contractual document. Product descriptions may differ from actual products. List of specifications is not comprehensive. The logos and visual identity of the company are the property of Manitou and may not be used without authorisation. All rights reserved. The photos and diagrams contained in this brochure are provided for information only.

MANITOU BF SA - Limited company with board of directors - Share capital: 39,668,399 euros - 857 802 508 RCS Nantes