

Farm King

OPERATOR AND PARTS MANUAL

Tandem Disc

Model 8700 - Heavy Duty - 3 Section



TABLE OF CONTENTS

Manufacturer’s Statement: For technical reasons, Buhler Industries Inc. reserves the right to modify machinery design and specifications provided herein without any preliminary notice. Information provided herein is of descriptive nature. Performance quality may depend on bale structure, applied techniques, weather conditions and other factors.

INTRODUCTION7

SAFETY11

ASSEMBLY25

OPERATION89

MAINTENANCE105

PARTS IDENTIFICATION127

SPECIFICATIONS193

WARRANTY203

ALPHABETICAL INDEX207

Farm King



WARRANTY REGISTRATION FORM

This form must be filled out by the dealer and signed by both the dealer and the customer at the time of delivery.

Customer Name:	Dealer Name:		
Customer Address:	Dealer Address:		
City:	Prov / State:	City:	Prov / State:
Postal / Zip Code:	Phone:	Postal / Zip Code:	Phone:

Equipment Name Model:	Serial Number:	Delivery Date:
-----------------------	----------------	----------------

I have thoroughly instructed the buyer on the above described equipment which review included the Operator's Manual content, equipment care, adjustments, safe operation and applicable warranty policy.

Dealer Inspection Report

<input type="checkbox"/>	Scrapers Adjusted Properly
<input type="checkbox"/>	Lubricate Machine
<input type="checkbox"/>	Level Machine
<input type="checkbox"/>	Hydraulic Lockout Valves Function Properly
<input type="checkbox"/>	Correct # Of Depth Stops
<input type="checkbox"/>	Wheel Bolt / Lug Nut Torque
<input type="checkbox"/>	Fasteners Tight
<input type="checkbox"/>	Front And Rear Gangs Set At Medium Angle
<input type="checkbox"/>	Adjust Mounted Harrows As Required (if equipped)
<input type="checkbox"/>	Check Overlap Measurement Of Front Gangs
<input type="checkbox"/>	Check Opening Measurement Between Two Inner Blades Of Rear Main Frame Gangs
<input type="checkbox"/>	Hydraulic Cylinders
<input type="checkbox"/>	Hydraulic Hoses
<input type="checkbox"/>	Electrical Harness
<input type="checkbox"/>	Tire Pressure

Safety

<input type="checkbox"/>	All Lights And Reflectors Installed
<input type="checkbox"/>	All Lights And Reflectors Cleaned And Working
<input type="checkbox"/>	Safety Chain On Hitch
<input type="checkbox"/>	All Decals Installed
<input type="checkbox"/>	Guards And Shields Installed And Secure
<input type="checkbox"/>	Review Operating And Safety Instructions
<input type="checkbox"/>	General Adjustment And Set-up Procedures
<input type="checkbox"/>	Transportation Requirements And Regulations

Date:	Dealer Rep. Signature:
-------	------------------------

The above equipment and Operator And Parts Manual have been received by me and I have been thoroughly instructed as to care, adjustments, safe operation and applicable warranty policy.

Date:	Customer / Owner's Signature:
-------	-------------------------------

Remove this Warranty Registration Form from the Operator And Parts Manual. Make two copies of the form. Send original Warranty Registration Form to Farm King. Give one copy to the customer and the dealer will keep one copy.

Farm King



INTRODUCTION

This Operator And Parts Manual was written to give the owner / operator instructions on the safe operation, maintenance and part identification of the Farm King equipment. Before operating your Farm King Tandem Disc, please take time to read and understand this manual to ensure best performance and longevity of this equipment. If you have any questions, see your Farm King dealer. This manual may illustrate options and accessories not installed on your Farm King equipment.

OWNER'S INFORMATION9
 Serial Number Location9
 Manual Storage9

EQUIPMENT IDENTIFICATION10
 Component Location10

Farm King



OWNER’S INFORMATION

Thank you for your decision to purchase a Farm King 8700 Tandem Disc. To ensure maximum performance of your equipment, it is mandatory that you thoroughly study the Operator And Parts Manual and follow all recommendations. Proper operation and maintenance are essential to maximize equipment life and prevent personal injury.

Operate and maintain this equipment in a safe manner and in accordance with all applicable local, state, and federal codes, regulations and / or laws. Follow all on-product labeling and instructions.

All personnel shall read this manual and understand the proper operation, installation and maintenance procedures before being allowed to work with it.

Farm King is continually working to improve its products. Farm King reserves the right to make any improvements or changes as deemed practical and possible without incurring any responsibility or obligation to make any changes or additions to equipment sold previously.

This publication has been professionally created ensuring its accuracy, Farm King makes no warranty or guarantee of any kind, written or expressed, implied or otherwise with regard to the information contained within this manual. Farm King assumes no responsibility for any errors that may appear in this manual and shall not be liable under any circumstances for incidental, consequential or punitive damages in connection with, or arising from the use of this manual.

Keep this manual available for frequent reference. All new operators or owners must review the manual before using the equipment and annually thereafter. Contact your Farm King Dealer if you need assistance, information, or additional copies of the manual. Visit our website at www.farm-king.com for a complete list of dealers in your area.

The directions left, right, front and rear, as mentioned throughout this manual, are as viewed from the rear of the equipment.

Serial Number Location

Please enter the model and serial number in the space provided for easy reference.

Figure 1

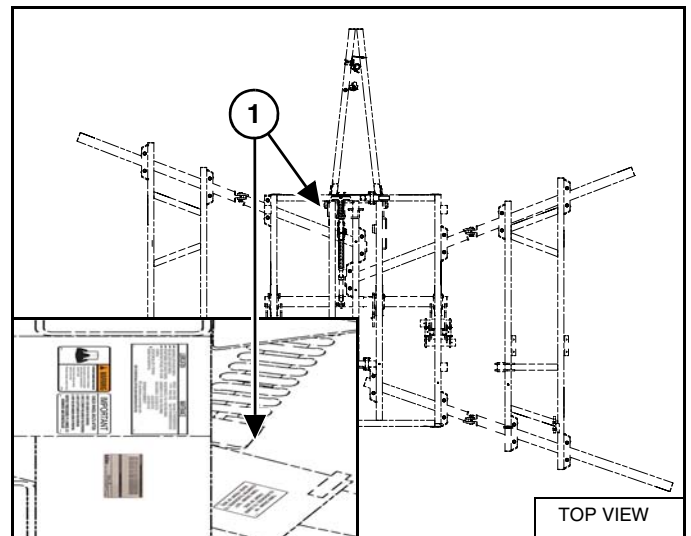

Model Number: _____

Serial Number: _____

The serial number plate (Item 1) [Figure 1] is located on the front left of the main frame.

Always use your serial number when requesting information or when ordering parts.

Manual Storage

Figure 2

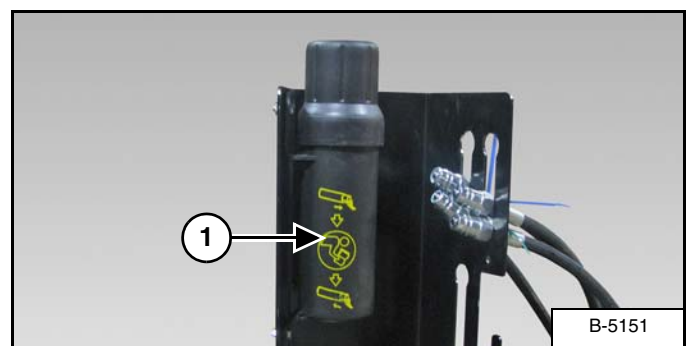

The Operator And Parts Manual and other documents can be stored in the canister (Item 1) [Figure 2] located on the front left side of the carrier.

EQUIPMENT IDENTIFICATION

Component Location

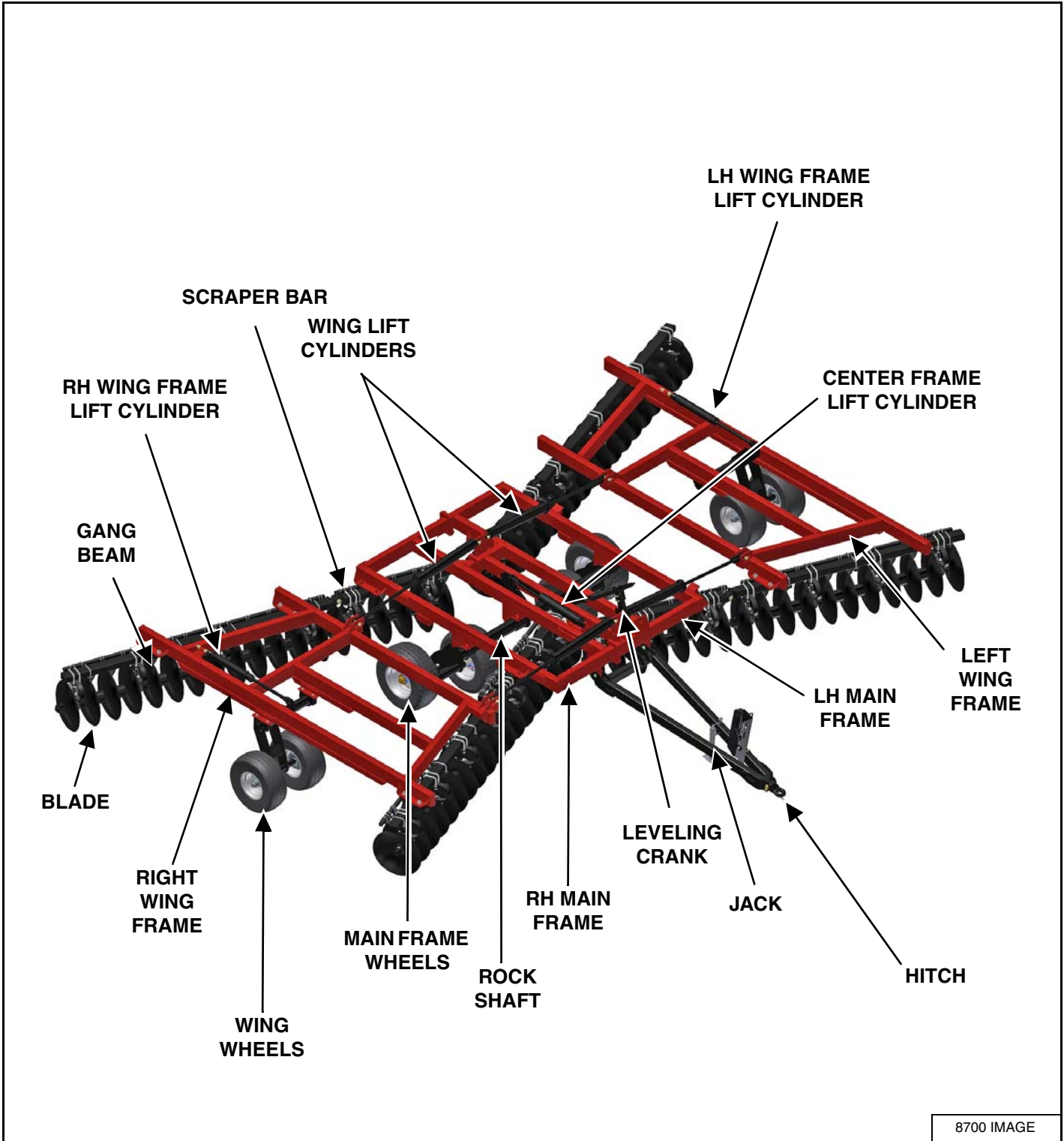

SAFETY

SAFETY INSTRUCTIONS 13

- Safe Operation Is The Operator’s Responsibility 13
- Safe Operation Needs A Qualified Operator 13
- Use Safety Rules 14
- Transport Safety 14
- Machine Requirements And Capabilities 15

FIRE PREVENTION 16

- Maintenance 16
- Operation 16
- Starting 16
- Electrical 16
- Hydraulic System 16
- Fueling 16
- Spark Arrester Exhaust System 16
- Welding And Grinding 17
- Fire Extinguishers 17

SAFETY SIGNS (DECALS) 18

EQUIPMENT DECALS AND SIGNS 23

SAFETY SIGN-OFF FORM 24

Farm King



SAFETY INSTRUCTIONS

Safe Operation Is The Operator’s Responsibility

	<p>Safety Alert Symbol</p>
<p>This symbol with a warning statement means: “Warning, be alert! Your safety is involved!” Carefully read the message that follows.</p>	



CAUTION

The signal word **CAUTION** on the machine and in the manuals indicates a potentially hazardous situation which, if not avoided, may result in minor or moderate injury. It may also be used to alert against unsafe practices.



DANGER

The signal word **DANGER** on the machine and in the manuals indicates a hazardous situation which, if not avoided, will result in death or serious injury.



WARNING

The signal word **WARNING** on the machine and in the manuals indicates a potentially hazardous situation which, if not avoided, could result in death or serious injury.



IMPORTANT

This notice identifies procedures which must be followed to avoid damage to the machine.

Safe Operation Needs A Qualified Operator



WARNING

Operators must have instructions before operating the machine. Untrained operators can cause injury or death.

For an operator to be qualified, he or she must not use drugs or alcoholic drinks which impair alertness or coordination while working. An operator who is taking prescription drugs must get medical advice to determine if he or she can safely operate a machine and the equipment.

A Qualified Operator Must Do The Following:

Understand the Written Instructions, Rules and Regulations

- The written instructions from Farm King include the Warranty Registration, Dealer Inspection Report, Operator And Parts Manual and machine signs (decals).
- Check the rules and regulations at your location. The rules may include an employer’s work safety requirements. Regulations may apply to local driving requirements or use of a Slow Moving Vehicle (SMV) emblem. Regulations may identify a hazard such as a utility line.

Have Training with Actual Operation

- Operator training must consist of a demonstration and verbal instruction. This training is given by the machine owner prior to operation.
- The new operator must start in an area without bystanders and use all the controls until he or she can operate the machine safely under all conditions of the work area. Always fasten seat belt before operating.

Know the Work Conditions

- Clear working area of all bystanders, especially small children and all obstacles that might be hooked or snagged, causing injury or damage.
- Know the location of any overhead or underground power lines. Call local utilities and have all underground power lines marked prior to operation.
- Wear tight fitting clothing. Always wear safety glasses when doing maintenance or service.

SAFETY INSTRUCTIONS (CONT'D)**Use Safety Rules**

- Read and follow instructions in this manual and the tractor's Operators Manual before operating.
- Under no circumstances should young children be allowed to work with this equipment.
- This equipment is dangerous to children and persons unfamiliar with its operation.
- If the elderly are assisting with work, their physical limitations need to be recognized and accommodated.
- Stay clear of overhead power lines when raising or lowering the wings. Electrocution can occur without direct contact.
- Check for overhead and / or underground lines before operating equipment (if applicable).
- In addition to the design and configuration of equipment, hazard control and accident prevention are dependent upon the awareness, concern, prudence and proper training of personnel involved in the operation, transport, maintenance and storage of equipment.
- Check that the equipment is securely fastened to the tractor.
- Make sure all the machine controls are in the NEUTRAL position before starting the machine.
- Operate the equipment only from the operator's position.
- Operate the equipment according to the Operator And Parts Manual.
- When learning to operate the equipment, do it at a slow rate in an area clear of bystanders, especially small children.
- DO NOT permit personnel to be in the work area when operating the equipment.
- The equipment shall only be used on approved tractors.
- DO NOT modify the equipment in any way. Unauthorized modification may void warranty, impair the function and / or safety and could affect the life of the equipment.
- DO NOT make any adjustments or repairs on the equipment while the machine is running.
- Keep shields and guards in place. Replace if damaged.

- Always relieve the pressure in hydraulic system and close both hydraulic lockup valves when the disc is not being operated.
- Always stay clear of the folding wing when it is being raised, lowered or placed in the folded position.
- When operating on hillsides, use extreme care. The tractor may tip over if it strikes a hole, ditch or other irregularity.

Transport Safety

- Do not exceed 10 mph (16 kph). Reduce speed on rough roads and surfaces.
- Comply with state and local laws governing highway safety and movement of machinery on public roads.
- Use the SMV emblem and warning light. Local laws should be checked for all highway lighting and marking requirements.
- Check all reflectors for visibility and cleanliness before transporting the disc.
- Always place both hydraulic lock up valves in "closed" position before transporting.
- Always install the complete package of depth control stops 17 in. (438.1 mm) in length on shaft of main frame cylinder.
- Always attach a safety chain to the tractor drawbar and the disc hitch before transporting the disc.
- Always yield to oncoming traffic in all situations and move to the side of the road so any following traffic may pass.
- Always enter curves or drive up or down hills at a low speed and at a gradual steering angle.
- Never allow riders on either tractor or equipment.
- Keep tractor in a lower gear at all times when traveling down steep grades.
- Maintain proper brake settings at all times (if equipped).
- Stay clear of overhead power lines when raising or lowering the wings. Electrocution can occur without direct contact.

Machine Requirements And Capabilities

- Fasten seat belt securely. If equipped with a foldable Roll-Over Protective Structure (ROPS), only fasten seat belt when ROPS is up and locked. Do not wear seat belt if ROPS is down.
 - Stop the machine and engage the parking brake. Install blocks in front of and behind the rear tires of the machine. Install blocks underneath and support the equipment securely before working under raised equipment.
 - Keep bystanders clear of moving parts and the work area. Keep children away.
 - Use increased caution on slopes and near banks and ditches to prevent overturn.
 - Make certain that the Slow Moving Vehicle (SMV) emblem is installed so that it is visible and legible. When transporting the equipment, use the flashing warning lights (if equipped) and follow all local regulations.
 - Operate this equipment with a machine equipped with an approved Roll-Over Protective Structure (ROPS). Always wear seat belt when the ROPS is up. Serious injury or death could result from falling off the machine.
- Before leaving the operator's position:
 1. Always park on a flat level surface.
 2. Place all controls in neutral.
 3. Engage the parking brake.
 4. Stop engine.
 5. Wait for all moving parts to stop.
 - Never allow riders on the machine or equipment. Falling off will result in serious injury or death. Only carry passengers in designated seating areas.
 - Start the equipment only when properly seated in the operator's seat. Starting a machine in gear can result in serious injury or death.
 - Operate the machine and equipment from the operator's position only.
 - The parking brake shall be engaged before leaving the operator's seat. Rollaway can occur because the transmission may not prevent machine movement.

FIRE PREVENTION



Maintenance

The machine and some equipment have components that are at high temperatures under normal operating conditions. The primary source of high temperatures is the engine and exhaust system. The electrical system, if damaged or incorrectly maintained, can be a source of arcs or sparks.

Flammable debris (leaves, straw, etc.) must be removed regularly. If flammable debris is allowed to accumulate, it can cause a fire hazard. Clean often to avoid this accumulation. Flammable debris in the engine compartment is a potential fire hazard.

The operator's area, engine compartment and engine cooling system must be inspected every day and cleaned if necessary to prevent fire hazards and overheating.

All fuels, most lubricants and some coolant mixtures are flammable. Flammable fluids that are leaking or spilled onto hot surfaces or onto electrical components can cause a fire.

Operation

The Farm King machine must be in good operating condition before use.

Check all of the items listed on the service schedule under the 8 hour column. (See "SERVICE SCHEDULE" on page 101.)

Do not use the machine where exhaust, arcs, sparks or hot components can contact flammable material, explosive dust or gases.

Starting

Do not use ether or starting fluids on any engine that has glow plugs. These starting aids can cause explosion and injure you or bystanders.

Use the procedure in the tractor's operator's manual for connecting the battery and for jump starting.

Electrical



Check all electrical wiring and connections for damage. Keep the battery terminals clean and tight. Repair or replace any damaged part or wires that are loose or frayed.

Battery gas can explode and cause serious injury. Do not jump start or charge a frozen or damaged battery. Keep any open flames or sparks away from batteries. Do not smoke in battery charging area.

Hydraulic System

Check hydraulic tubes, hoses and fittings for damage and leakage. Never use open flame or bare skin to check for leaks. Hydraulic tubes and hoses must be properly routed and have adequate support and secure clamps. Tighten or replace any parts that show leakage.

Always clean fluid spills. Do not use gasoline or diesel fuel for cleaning parts. Use commercial nonflammable solvents.

Fueling



Stop the engine and let it cool before adding fuel. No smoking! Do not refuel a machine near open flames or sparks. Fill the fuel tank outdoors.

Spark Arrester Exhaust System

The spark arrester exhaust system is designed to control the emission of hot particles from the engine and exhaust system, but the muffler and the exhaust gases are still hot.

Check the spark arrester exhaust system regularly to make sure it is maintained and working properly. Use the procedure in the machine's Operator's Manual for cleaning the spark arrester muffler (if equipped).

FIRE PREVENTION (CONT'D)**Welding And Grinding**

Always clean the machine and equipment, disconnect the battery, and disconnect the wiring from the machine controls before welding. Cover rubber hoses, battery and all other flammable parts. Keep a fire extinguisher near the machine when welding.

Have good ventilation when grinding or welding painted parts. Wear dust mask when grinding painted parts. Toxic dust or gas can be produced.

Dust generated from repairing nonmetallic parts such as hoods, fenders or covers can be flammable or explosive. Repair such components in a well ventilated area away from open flames or sparks.

Fire Extinguishers

Know where fire extinguishers and first aid kits are located and how to use them. Inspect the fire extinguisher and service the fire extinguisher regularly. Obey the recommendations on the instructions plate.

SAFETY SIGNS (DECALS)

Follow the instructions on all the Signs (Decals) that are on the equipment. Replace any damaged signs (decals) and be sure they are in the correct locations. Equipment signs are available from your Farm King equipment dealer.

Decal Locations (Top View)

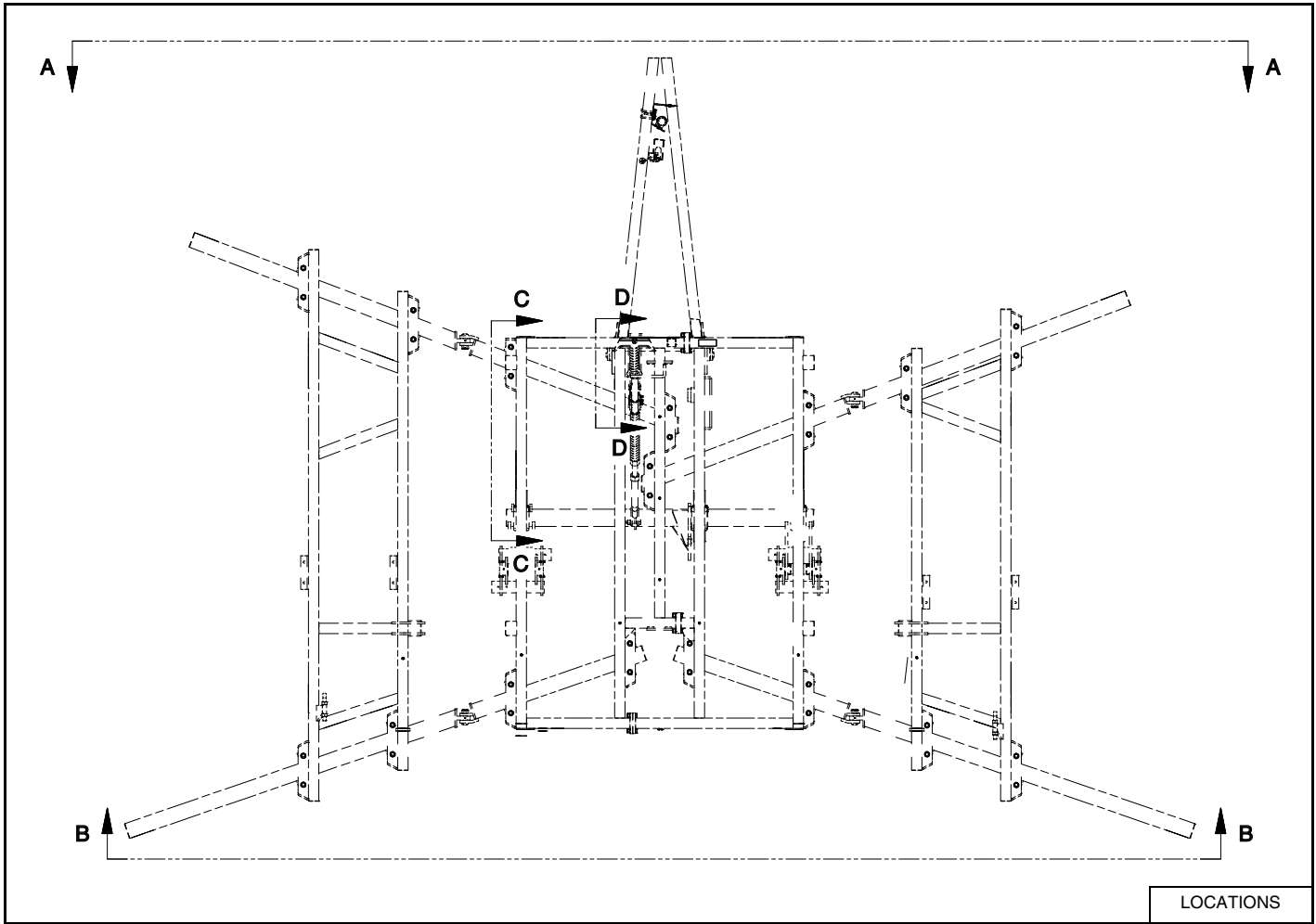

DECAL LOCATION	PAGE #
A - A	19
B - B	20
C - C	21
D - D	22

Location A - A (Front)

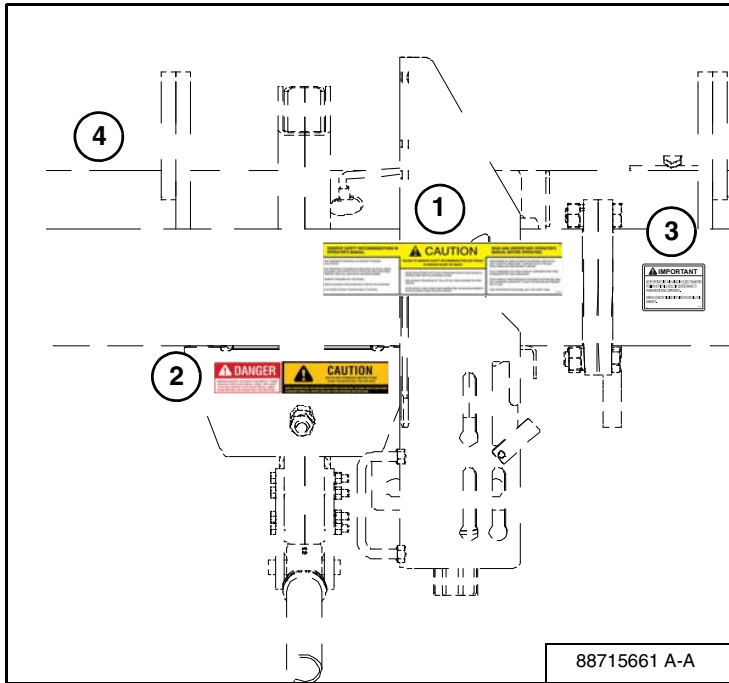

3

IMPORTANT

NEVER OPERATE DISC WITH WINGS IN FOLDED (TRANSPORT) POSITION AS THIS WILL RESULT IN SEVERE DAMAGE TO FRAME AND/OR GANG COMPONENTS.

DAMAGE CAUSED BY DISCING WITH WINGS FOLDED WILL VOID WARRANTY.

B10 DF13120

P/N EZDF13120

4

IMPORTANT	WARNING
<p>TRANSPORT LOCKUP VALVES</p> <p>LIFT WINGS</p> <p>CLOSED (TRANSPORT OR PARK) OPEN (FIELD POSITION)</p>	<ul style="list-style-type: none"> TO PREVENT ACCIDENTAL OPERATION OF HYDRAULIC SYSTEM WHILE TRANSPORTING MACHINE ALWAYS PLACE LOCKUP VALVES IN CLOSED POSITION. ALWAYS RELEASE HYDRAULIC PRESSURE IN ALL CYLINDERS AND CLOSE HYDRAULIC LOCKUP VALVES BEFORE UNHITCHING FROM TRACTOR OR WHEN PARKING WITH TRACTOR. THIS WILL PREVENT WINGS FROM UNFOLDING AND FALLING DUE TO THERMAL EXPANSION OF HYDRAULIC OIL, CAUSING MACHINE DAMAGE, PROPERTY DAMAGE OR INJURY OR DEATH TO PERSONS NEARBY. ALWAYS BLOCK UP FRAME OR LOWER MACHINE TO GROUND WHEN SERVICING OR REPAIRING MACHINE. DO NOT RELY ON LOCKUP VALVE AS A SAFETY DEVICE WHEN WORKING ON MACHINE. <p>EZDF13001</p>

P/N EZDF13001

1

<p>OBSERVE SAFETY RECOMMENDATIONS IN OPERATOR'S MANUAL.</p> <p>WHEN TRANSPORTING THIS MACHINE, LOCK ROCKSHAFT BY ENGAGING LOCK-UP DEVICES.</p> <p>WHEN TRANSPORTING THIS MACHINE OVER PUBLIC ROADS, USE THE S.M.V. EMBLEM AND WARNING LIGHTS FOR PROTECTION OF TRACTOR AND OTHER MOTOR VEHICLE OPERATORS. CHECK LOCAL LAWS FOR WIDTH AND WEIGHT MAXIMUMS.</p> <p>TRANSPORT THIS MACHINE WITH A TRACTOR ONLY.</p> <p>NEVER ALLOW ANYONE TO RIDE ON DRAW BAR OF TRACTOR OR ON THIS MACHINE.</p> <p>DO NOT SERVICE OR ADJUST THIS MACHINE WHILE IT IS IN MOTION.</p>	<p>CAUTION</p> <p>FAILING TO OBSERVE SAFETY RECOMMENDATIONS MAY RESULT IN SERIOUS INJURY OR DEATH.</p> <p>NEVER STAND BETWEEN TRACTOR AND THIS MACHINE WHEN HITCHING UNLESS ALL CONTROLS ARE IN NEUTRAL AND BRAKES LOCKED.</p> <p>PARK OR BLOCK THIS MACHINE SO IT WILL NOT ROLL WHEN DISCONNECTED FROM TRACTOR.</p> <p>DO NOT EXCEED 10 MPH (16KM/H) WHEN TRANSPORTING THIS MACHINE ON SMOOTH SURFACES. REDUCE SPEED ON ROUGH SURFACES.</p>	<p>READ AND UNDERSTAND OPERATOR'S MANUAL BEFORE OPERATING.</p> <p>WHEN WORKING ON, UNDER OR AROUND THIS MACHINE, ALWAYS PLACE SAFETY SUPPORTS UNDER FRAME. IF SUPPORTS ARE NOT AVAILABLE, UNFOLD WINGS AND LOWER MACHINE TO GROUND.</p> <p>DO NOT DISASSEMBLE OR LOOSEN HYDRAULIC COMPONENTS WHEN THERE IS PRESSURE WITHIN THOSE COMPONENTS.</p> <p>CHECK HYDRAULIC HOSES PERIODICALLY FOR SIGNS OF RUPTURE AND LEAKS. USE A CARDBOARD AS BACKSTOP TO CHECK FOR ESCAPING HIGH PRESSURE OR HOT FLUID.</p> <p>WHEN TRANSPORTING THIS MACHINE, USE A HITCH SAFETY CHAIN.</p> <p>M014 EZDF9510</p>
--	---	---

P/N EZDF9510

2

DANGER

SERIOUS INJURY OR DEATH CAN RESULT FROM CONTACT WITH ELECTRICAL LINES. USE CARE TO AVOID CONTACT WITH ELECTRICAL LINES WHEN MOVING OR OPERATING THIS MACHINE.

CAUTION

WATCH FOR OVERHEAD OBSTRUCTIONS WHEN TRANSPORTING THIS MACHINE

WHEN TRANSPORTING THIS MACHINE WITH WINGS FOLDED (UP), BE SURE THERE IS SUFFICIENT CLEARANCE UNDER ALL POWER LINES AND OTHER OVERHEAD OBSTRUCTIONS.

P/N EZDF9506

Location B - B (Rear)

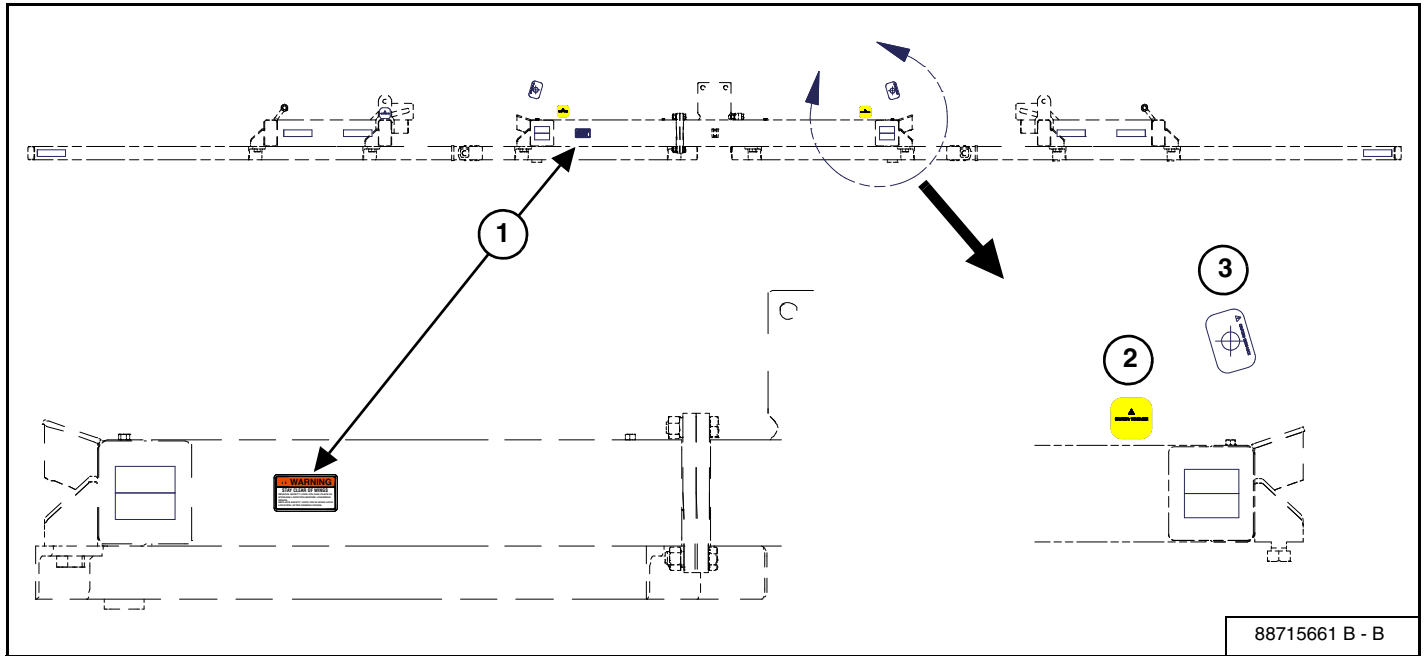

1



P/N 88715832

2



P/N 88715891

3



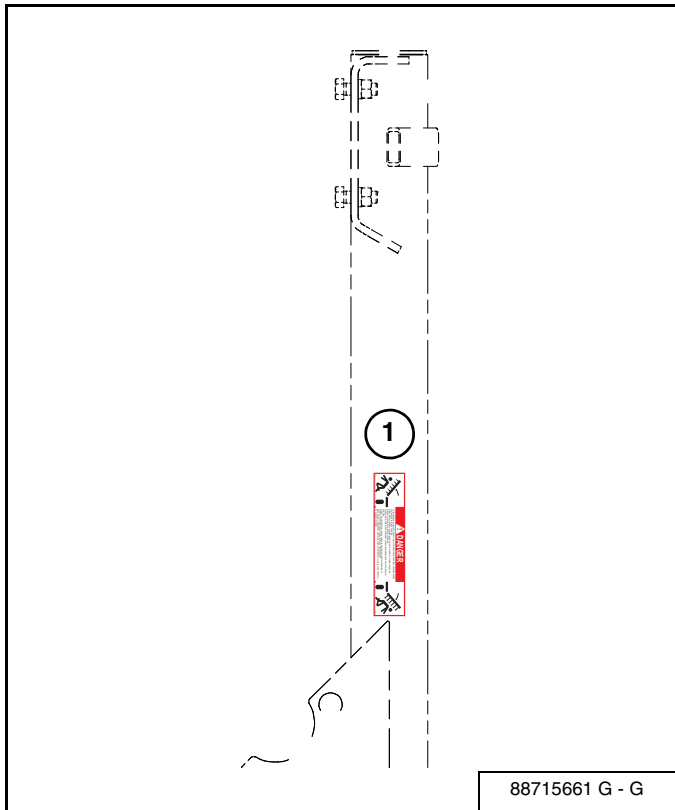

P/N 88715890

Location G - G (Side Main Frame)



1

	<p>! DANGER</p> <p>TO AVOID PERSONAL INJURY OR DEATH, ALWAYS STAND CLEAR WHEN WINGS ARE BEING RAISED, LOWERED OR IN FOLDED POSITION. WINGS MAY FALL RAPIDLY, CAUSING BODILY INJURY IF HYDRAULIC SYSTEM FAILED OR IF HYDRAULIC LEVER IS ACCIDENTLY OPERATED. ALWAYS INSTALL WING LOCK-UP DEVICES (IF PROVIDED) WHEN WINGS ARE IN FOLDED (UP) POSITION. ALWAYS CLOSE HYDRAULIC LOCK-UP VALVES TO PREVENT ACCIDENTAL OPERATION OF HYDRAULIC SYSTEMS WHEN MACHINE IS FOLDED FOR TRANSPORT. MAKE SURE CYLINDERS ARE COMPLETELY FILLED WITH HYDRAULIC FLUID TO AVOID FREE-FALL OR SUDDEN MOVEMENT.</p>	
---	---	---

P/N EZDF9507

Location K - K (Front Left Of Main Frame)

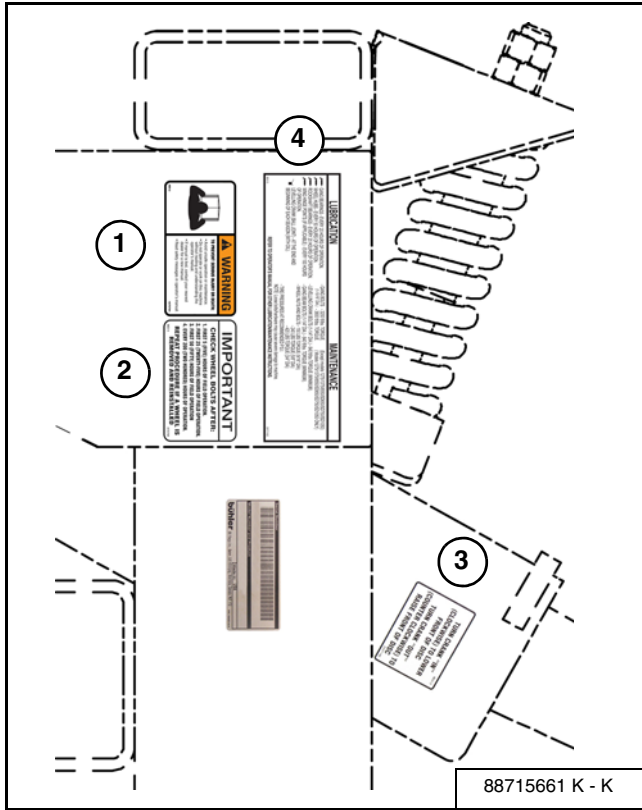

88715661 K - K

2

IMPORTANT

CHECK WHEEL BOLTS AFTER:

1. FIRST 5 (FIVE) HOURS OF FIELD OPERATION.
2. FIRST 25 (TWENTY-FIVE) HOURS OF FIELD OPERATION.
3. FIRST 50 (FIFTY) HOURS OF FIELD OPERATION
4. EVERY 200 (TWO HUNDRED) HOURS OF OPERATION.

REPEAT PROCEDURE IF A WHEEL IS REMOVED AND REINSTALLED

MG14 A75759

P/N EZA75759

3

MG12

**TURN CRANK "IN"
(CLOCKWISE) TO LOWER
FRONT OF DISC**

**TURN CRANK "OUT"
(COUNTER CLOCKWISE) TO
RAISE FRONT OF DISC**

DH7148

P/N EZDH7148

1

WARNING

TO PREVENT SERIOUS INJURY OR DEATH:

- Avoid unsafe operation or maintenance.
- Do not operate or work on this machine without reading and understanding the operator's manual.
- If manual is lost, contact your nearest dealer for a new manual.
- Read safety messages in operator's manual.

HD12 #A75764

P/N EZA75764

4

LUBRICATION	MAINTENANCE
<ul style="list-style-type: none"> — GANG BEARINGS - EVERY 20 HOURS OF OPERATION. — WHEEL HUBS - EVERY 50 HOURS OF OPERATION. — ROCKSHAFT BEARINGS - EVERY 20 HOURS OF OPERATION. — WING HINGE POINTS (IF APPLICABLE) - EVERY 100 HOURS OF OPERATION. — LEVELLING CRANK (BALL JOINT) - AT THE END AND BEGINNING OF EACH SEASON (WITH OIL). 	<ul style="list-style-type: none"> - GANG BOLTS - 3200 ft/lbs. TORQUE. (Except models 1275/1375/8550/SD650/SD750/SD1050) (1-15/16" DIA.) - 3800 ft/lbs. TORQUE. (Models 1275/1375/8550/SD650/SD750/SD1050 ONLY) - LEVELLING CRANK BOLTS (1-1/4" DIA.) - 840 ft/lbs TORQUE (MINIMUM). - GANG BEAM BOLTS (1-1/4" DIA.) - 840 ft/lbs. TORQUE (MINIMUM). - WHEEL NUTS AND BOLTS - 150 LBS TORQUE (9/16" DIA) - 240 LBS TORQUE (5/8" DIA) - 420 LBS TORQUE (3/4" DIA) - TIRE PRESSURES AT RECOMMENDED P.S.I. <p>NOTE: Loose bolts/hardware may cause severe damage to machine.</p>
BS13	DF7152

REFER TO OPERATOR'S MANUAL FOR OTHER LUBRICATION/MAINTENANCE INSTRUCTIONS.

P/N EZDF7152

EQUIPMENT DECALS AND SIGNS

NOTE: All safety related decals are shown in the Safety Signs Section. (See “SAFETY SIGNS (DECALS)” on page 18.)

Check and replace any worn, torn, hard to read or missing decals on your equipment.

p/n EZDF10057 (Amber)



p/n EZDF10061 (Amber)



p/n EZDF13119



p/n 21867



p/n 88704512



p/n 88704513

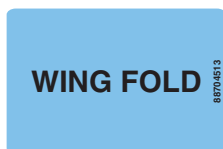

p/n EZDF10050 (Red)



p/n EZDF10060 (Red)



p/n EZDF13357



ASSEMBLY

GENERAL ASSEMBLY INFORMATION27
 Component Unloading And Identification27

BASE GROUP28
 Center Frame Assembly28
 Installing The Main Frame Rockshaft31
 Installing The Main Frame Spindles and Wheels34
 Installing The Hitch35
 Installing The Leveling Crank Assembly36
 Installing The Gang Beams37
 Installing The Wing Gang Beams38
 Installing The Wing Frames39
 Installing The Wing Rockshafts41

HYDRAULICS45
 Installing Main Frame Rockshaft Hydraulic Cylinder45
 Installing Wing Lift Cylinders47
 Installing Wing Rockshaft Hydraulic Cylinders48
 Installing Hydraulic Control Valves49
 Installing Hydraulic Fittings50
 Hydraulic Hose Identification - 21.25” Frame53
 Hydraulic Hose Identification - 38.5” Frame54
 Hydraulic Hose Identification - 80.625” Frame55
 Hydraulic Hose Installation And Routing57

PURGING / REPHASING HYDRAULIC SYSTEM63
 Purging Hydraulic System63
 Rephasing Hydraulic System63

GANG SECTIONS64
 Gang Beam Extension Chart64
 General Information65
 Installing The Gang Sections66
 Installing The Scraper Bar And Scrapers75
 Installing Hydraulic Hose Bracket77
 Installing Manual Storage Container78

LIGHT KIT79
 Installation79

DEPTH STOPS81

GANG PATTERNS82

- 10-1/2 Inch Spacing - 58 Blades / 20 Bearings82
- 10-1/2 Inch Spacing - 62 Blades / 20 Bearings82
- 10-1/2 Inch Spacing - 66 Blades / 22 Bearings83
- 10-1/2 Inch Spacing - 74 Blades / 24 Bearings83
- 10-1/2 Inch Spacing - 82 Blades / 28 Bearings84
- 10-1/2 Inch Spacing - 90 Blades / 32 Bearings84
- 12 Inch Spacing - 50 Blades / 20 Bearings85
- 12 Inch Spacing - 54 Blades / 20 Bearings85
- 12 Inch Spacing - 58 Blades / 22 Bearings86
- 12 Inch Spacing - 62 Blades / 24 Bearings86
- 12 Inch Spacing - 66 Blades / 24 Bearings87
- 12 Inch Spacing - 74 Blades / 26 Bearings87
- 12 Inch Spacing - 78 Blades / 28 Bearings88

GENERAL ASSEMBLY INFORMATION

Component Unloading And Identification



ELECTROCUTION HAZARD

To prevent serious injury or death from electrocution:

- Be aware of overhead power lines.
- Keep away from power lines when unloading and assembling the disc.
- Electrocution can occur without direct contact.



- DO NOT permit bystanders to be in the work area when unloading and assembling the disc components.
- DO NOT work under suspended parts.
- Keep away from moving parts.
- Always use lifting devices / vehicles, chains or straps of adequate size and strength when unloading and assembling the disc components.

Unload the crate(s) and components on a flat level area of adequate size to assemble the 8700 Tandem Disc.



Unload crate(s) and disc components carefully to prevent damage to any of the components.

NOTE: If any components are damaged, missing or replacement parts are required, contact your Farm King Dealer.

Assemble the 8700 Tandem Disc in the following order:

1. Center Frame (See “Center Frame Assembly” on page 28.)

Using the packing list, locate and place all center frame components and hardware in one area. Count the individual components and verify that you have received the correct number of components to fully assemble the center frame.

2. Wings

Using the packing list, locate and place all wing components and hardware in one area. Count the individual components and verify that you have received the correct number of components to fully assemble the wings.

3. Gang Beam Extensions

Using the packing list, locate and place all gang beam extension components and hardware in one area. Count the individual components and verify that you have received the correct number of components to fully assemble the gang beam extensions.

4. Hydraulic

Using the packing list, locate and place all hydraulic components in one area. Count the individual components and verify that you have received the correct number of components to fully assemble the hydraulics.

Figure 3



Larger components are marked for identification [Figure 3].

BASE GROUP

Center Frame Assembly

Assemble the undercarriage on a flat level surface.

NOTE: The following images throughout the assembly section of this manual may not show your exact tandem disc components as they appear but the procedure is correct for all 8700 Tandem Discs.



- DO NOT permit bystanders to be in the work area when lowering, raising or folding wing.
- DO NOT work under suspended parts.
- Keep away from moving parts.
- Always use lifting devices / vehicles, chains or straps of adequate size and strength when unloading and assembling the tandem disc components.



Always use chains, straps and lifting devices that are in good condition and of adequate size to lift the tandem disc components.

NOTE: Support stands are recommended when assembling the main frame of the tandem disc.

Figure 4

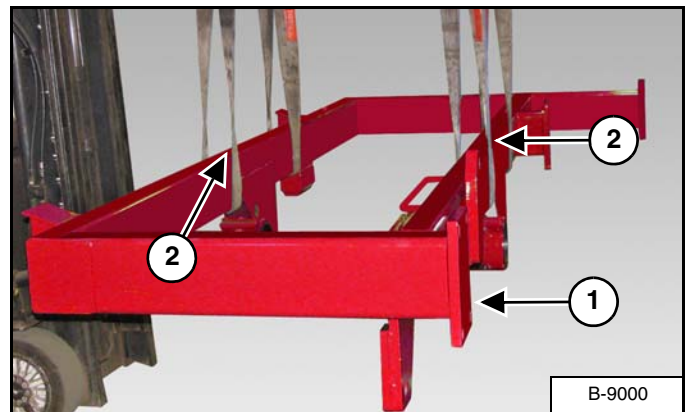

Locate LH main frame section (Item 1). Install straps (Item 2) [Figure 4] around the LH main frame section.

Connect the straps to an approved lifting device.

Raise and move the LH main frame section to the assembly area.

Lower the LH main frame section onto support stands and remove straps.

Repeat procedure for RH main frame section.



AVOID INJURY OR DEATH

Keep fingers and hands out of pinch points when assembling the equipment.

Figure 5

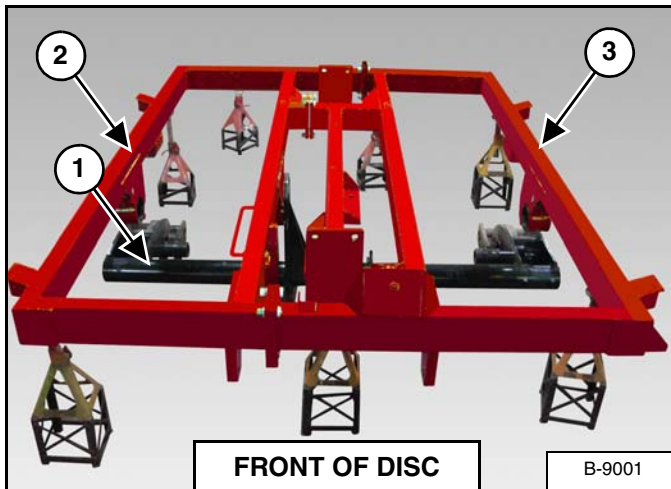

Locate the main frame rockshaft (Item 1) [Figure 5]. Install straps around the main frame rockshaft.

Connect the straps to an approved lifting device.

Raise and move the main frame rockshaft to the assembly area.

Position the RH (Item 2) & LH (Item 3) [Figure 5] main frame sections over the main frame rockshaft.

Figure 6

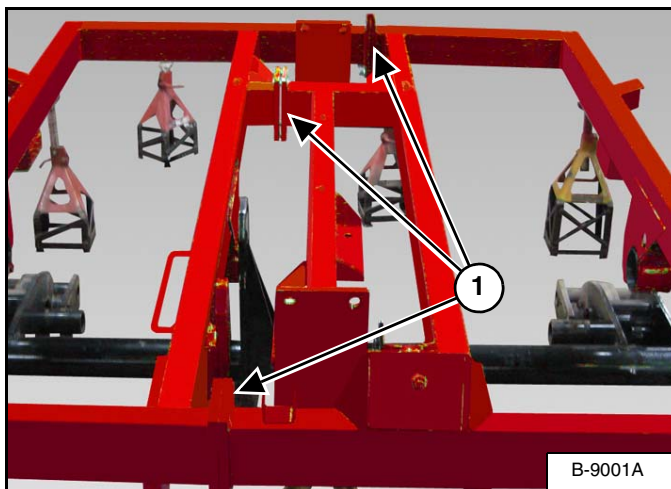

Align the three center connecting flanges (Item 1) [Figure 6] of the RH & LH main frame sections.

Figure 7

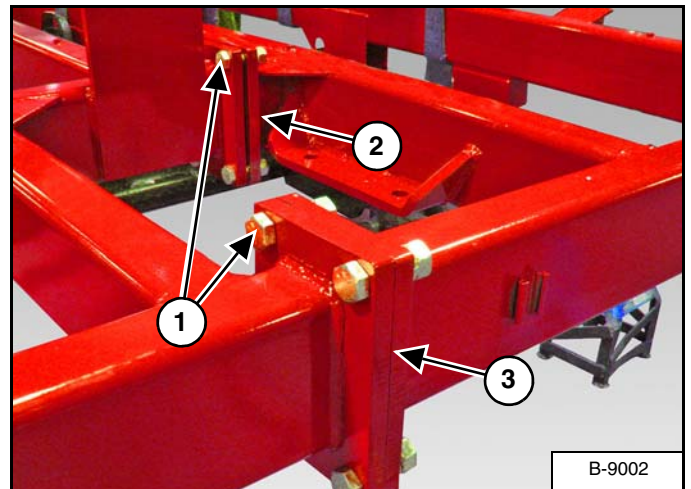

Install four 1" x 3-1/4" bolts (Item 1) through the RH & LH main frames center (Item 2) and rear (Item 3) [Figure 7] connecting flanges.

Install one 1" lock washer and 1" nut onto each bolt. Do not tighten at this time.

Figure 8

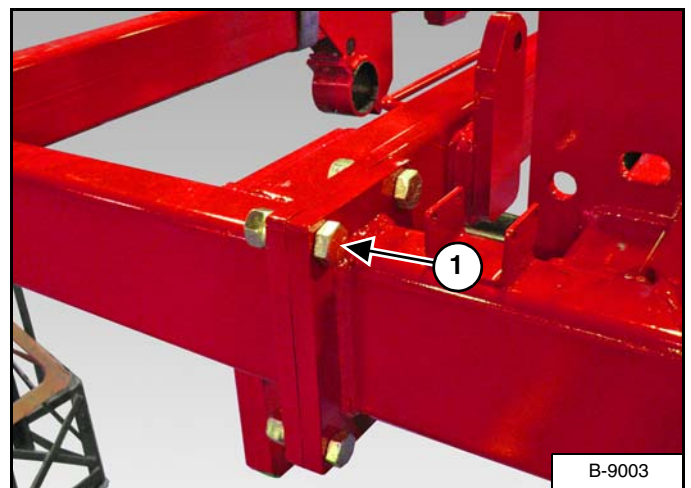

Install four 1" x 3-1/4" bolts (Item 1) [Figure 8] through the RH & LH main frames front connecting flanges.

Install one 1" lock washer and 1" nut onto three remaining bolts. Do not tighten at this time.

! IMPORTANT



If the center LH and RH main frame connecting flanges have a gap after tightening the front and rear connecting flanges, install two hole shims between center connecting flanges to take up the gap.

Figure 9

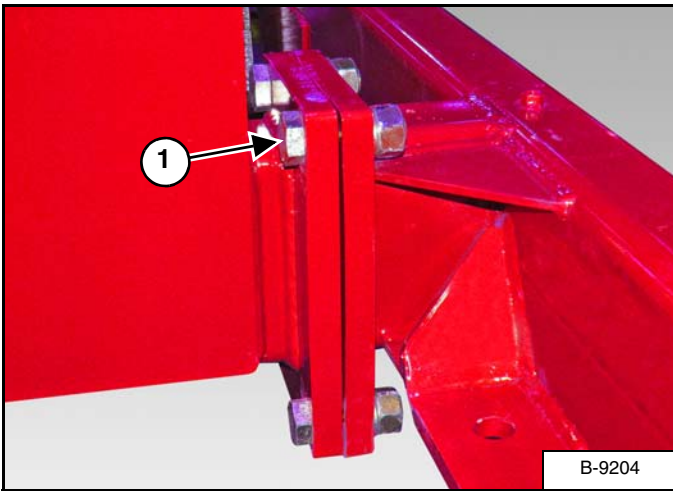

Tighten four 1" x 3-1/4" bolts (Item 1) [Figure 9] on the center RH & LH main frame connecting flanges.

Figure 10

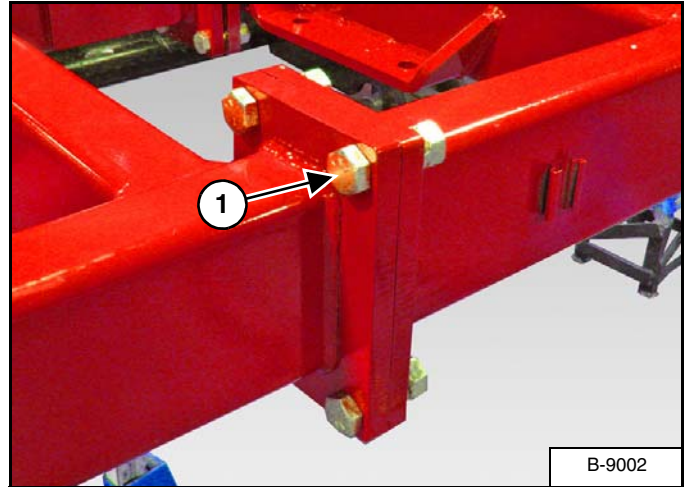

Tighten the four 1" x 3-1/4" bolts (Item 1) [Figure 10] on the rear RH & LH main frame connecting flanges.

Repeat for front connecting flanges.

Installing The Main Frame Rockshaft

Figure 11

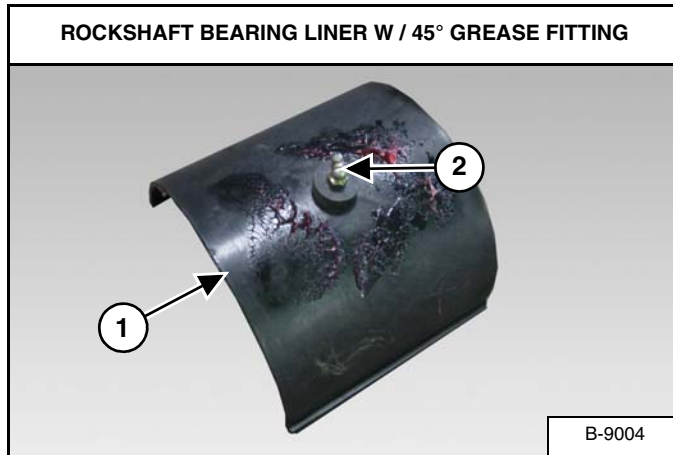

Locate the three rockshaft bearing liners (Item 1) [Figure 11].

Locate and install one 45° grease fitting (Item 2) [Figure 11] (if required) into the three rockshaft bearing liners.

Apply thin layer of grease to rockshaft bearing liners.

! IMPORTANT

UPPER ROCKSHAFT BEARING LINERS

Always install the upper rockshaft bearing liners with the grease fitting on the same side as the tire attached, except for the center rockshaft bearing. Always install the center upper rockshaft bearing with the grease fitting towards the rear.

Figure 12

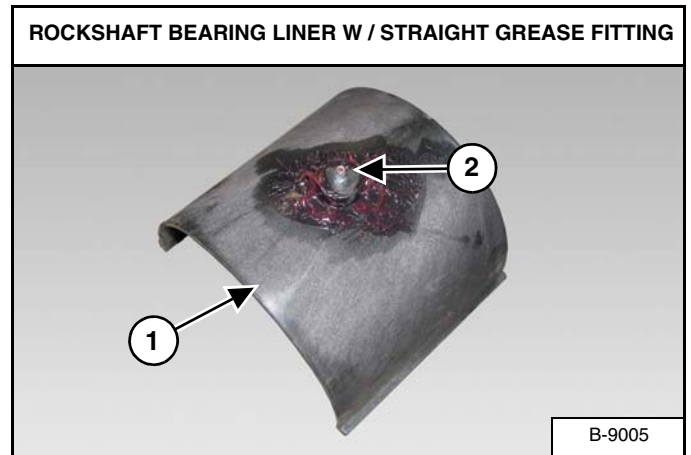

Locate the three rockshaft bearing liners (Item 1) [Figure 12].

Locate and install one straight grease fitting (Item 2) [Figure 12] (if required) into the three rockshaft bearing liners.

Apply thin layer of grease to rockshaft bearings.

! IMPORTANT

LOWER ROCKSHAFT BEARING LINERS

Always install the lower rockshaft bearing liners with the grease fitting opposite of the upper rockshaft bearing grease fitting.

Figure 13

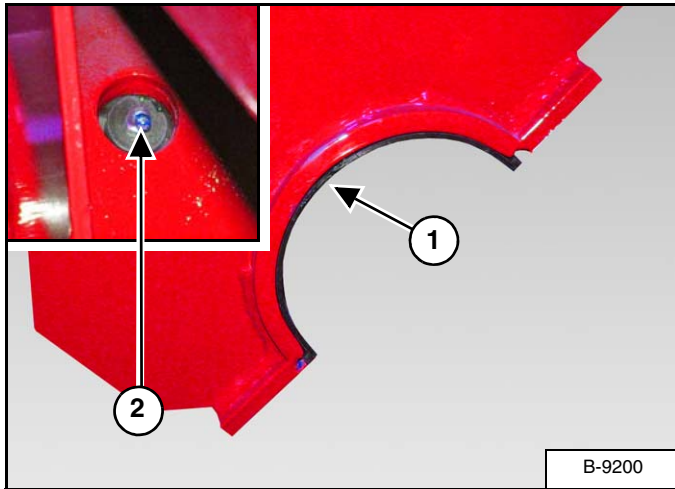

Install the three rockshaft bearing liners (Item 1) [Figure 13] (With 45° grease fittings) into the upper rockshaft mounts on the main frame.

NOTE: Verify that the 45° grease fitting (Item 2) [Figure 13] is centered in the hole of the upper rockshaft mounts on the main frame.

Figure 14

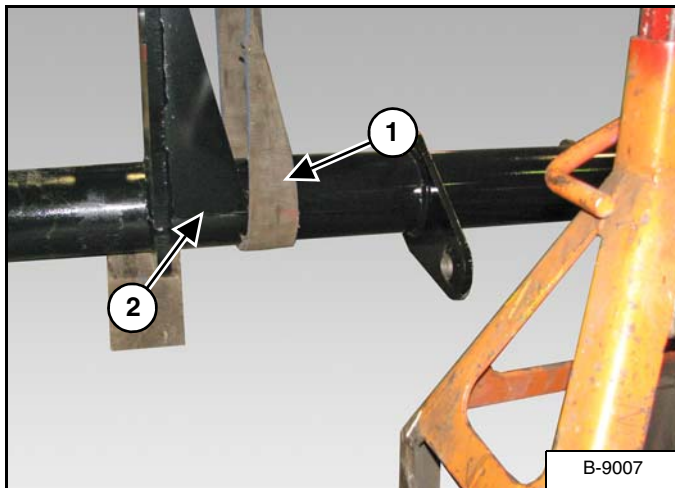

Install straps (Item 1) around the main frame rockshaft (Item 2) [Figure 14].

Connect the straps to an approved lifting device.

Figure 15

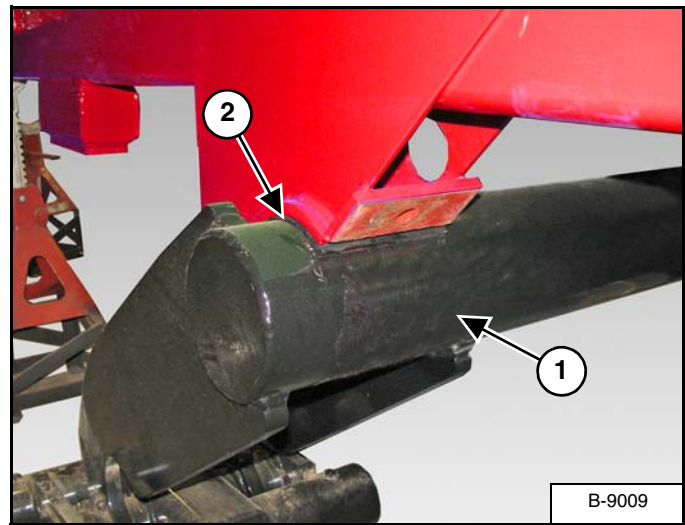

Raise the main frame rockshaft.

Position rockshaft (Item 1) [Figure 15] so that outside bearings are positioned between wheel legs.

Continue lifting until the rockshaft contacts the upper rockshaft bearing liners (Item 2) [Figure 15].

! IMPORTANT



Always install the correct number of shims between the upper rockshaft mounts and saddle caps when installing the main rockshaft.

**Upper Flange - Three shims
Lower Flange - Four shims**

Figure 16

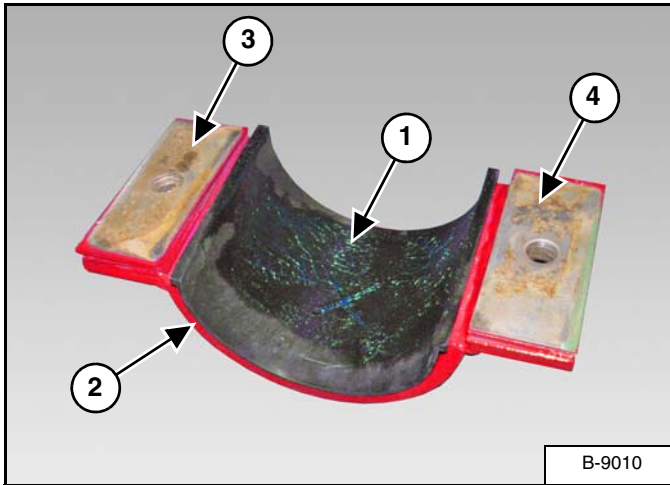

Place one lower rockshaft bearing liner (Item 1) (with straight grease fitting) onto the three saddle caps (Item 2) [Figure 16].

Place three shims on the upper flange (Item 3) and four shims on the lower flange (Item 4) [Figure 16].

Figure 17

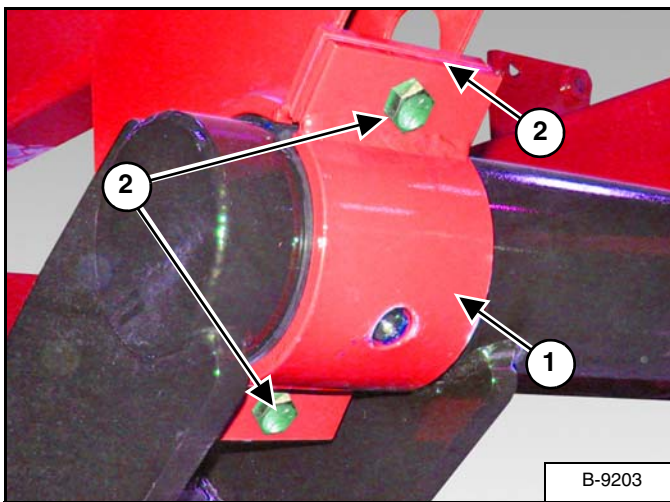

Place the saddle cap (Item 1) over the rockshaft and install the two 3/4" x 2-1/2" bolts (Item 2) [Figure 17] through the upper main frame rockshaft mounts.

Install one 3/4" lock washer and 3/4" nut on each bolt.

Repeat for install the two remaining saddle cap assemblies.

Figure 18

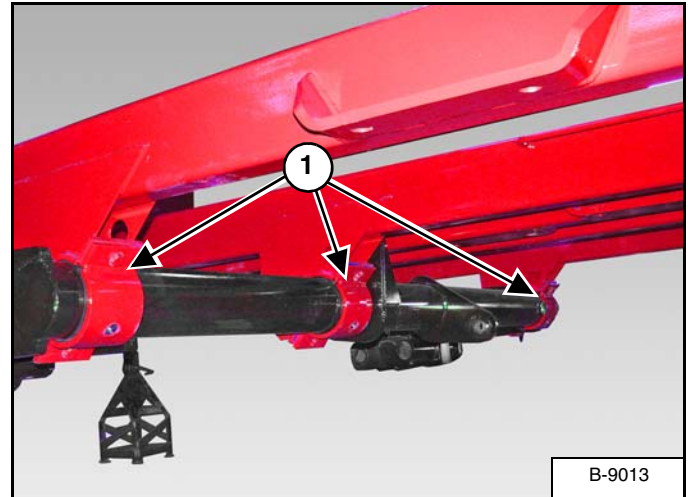

Tighten bolts and nuts (Item 1) [Figure 18] to secure the main rockshaft to the main frame assembly.

Slowly lower / raise the main frame rockshaft.

NOTE: Rockshaft must move / rotate freely inside the upper & lower rockshaft mounts.

Figure 19

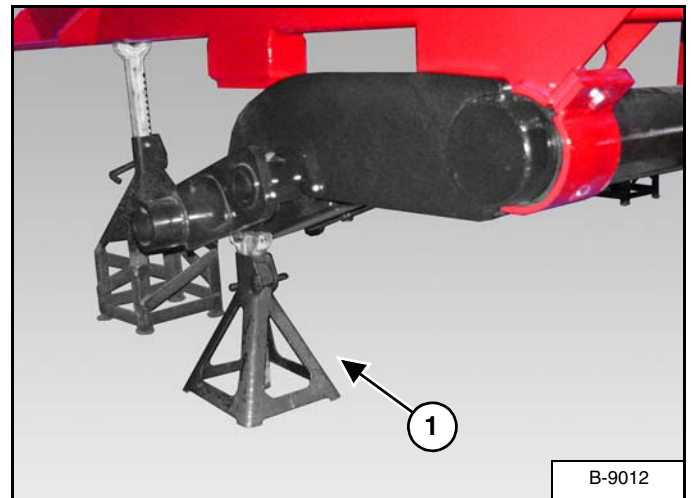

Lift rockshaft and install jackstand (Item 1) [Figure 19] under the left / right side of the rockshaft. Lower the rockshaft onto the jackstand.

Verify all bearing grease fittings are facing the correct directions.

Installing The Main Frame Spindles and Wheels

NOTE: The following procedure shows the spindles and wheels on the RH side of the main frame. The procedure is the same for the LH side of the main frame.

Figure 20

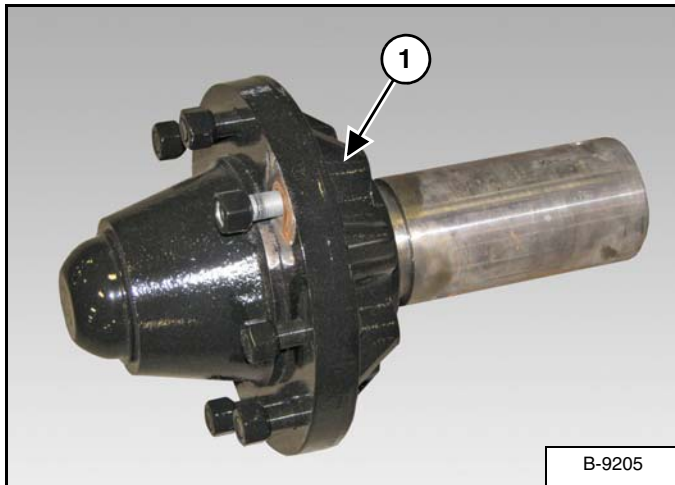

Locate four hub assemblies with (large) spindles (Item 1) [Figure 20].

Remove the eight 9/16" NF nuts from each spindle.

Figure 21

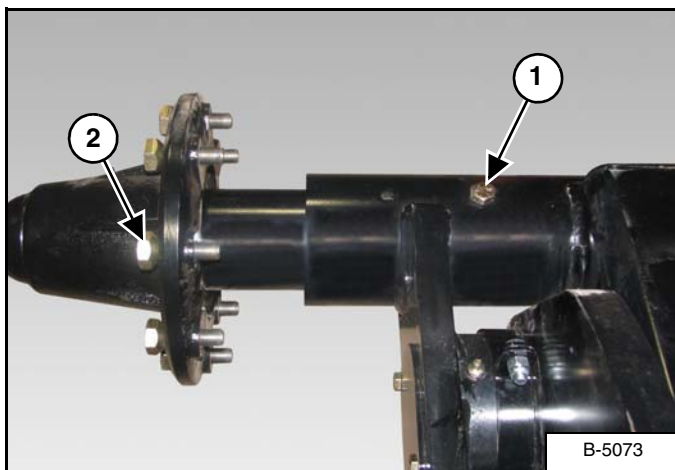

Align spindle mounting hole with the inner mounting hole (Item 1) [Figure 21] of the walking beam (both sides).

Install one 1/2" x 5-1/2" Grade 5 bolt through the walking beam and spindle (both sides). Install one 1/2" lock nut on the bolt and tighten (both sides).

Remove the eight 9/16" NF x 1-1/8" wheel bolts (Item 2) [Figure 21].

Figure 22



Tire Size 12.5L x 15 FI

Align wheel (Item 1) with the spindle. Install the eight 9/16" NF x 1-1/8" wheel bolts (Item 2) [Figure 22] (both wheels).

Tighten wheel bolts in a criss-cross pattern to 130 ft.-lb. (176.3 N•m) torque.

Repeat the following procedures for the LH side of main frame.

Install LH spindles and wheels. (See "Installing The Main Frame Spindles and Wheels" on page 34.)

Installing The Hitch

Locate the hitch assembly. Install straps around the hitch assembly.

Using a forklift, position forks under the hitch assembly. Raise and move the hitch assembly to the assembly area.

Figure 23

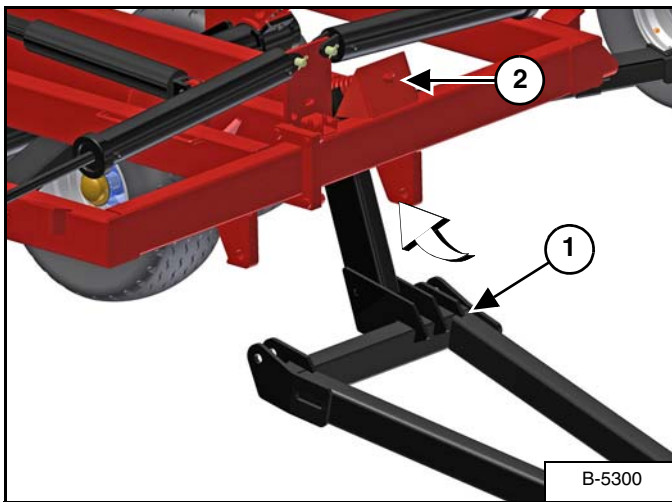

Lower and guide the hitch assembly (Item 1) under the front of the main frame assembly, below the compression spring mounting plate (Item 2) [Figure 23].

Figure 24

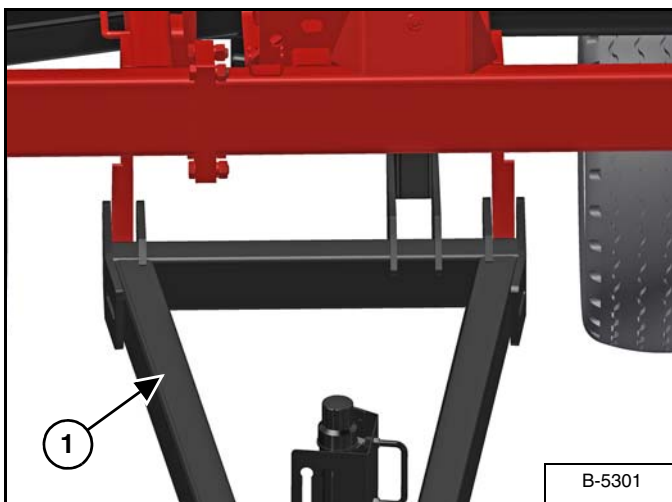

Using a forklift, raise the hitch assembly (Item 1) [Figure 24], aligning the hitch mounts with the mounting brackets on the main frame.

Figure 25

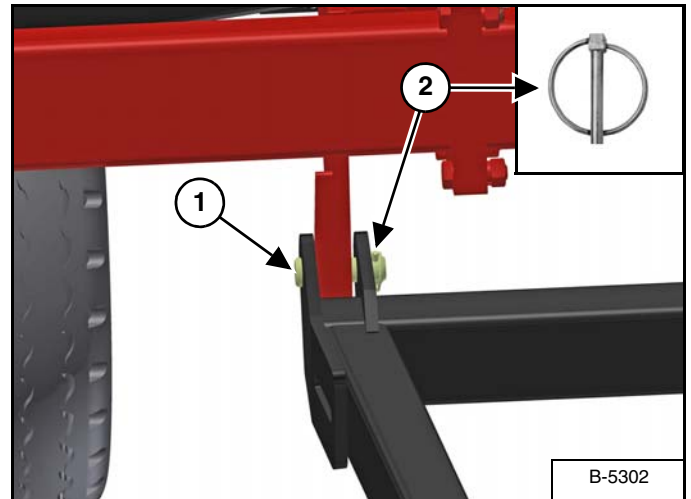

Locate the two hitch mounting pins (Item 1) [Figure 25]. Install the hitch mounting pin through the outer hitch mount, main frame mounting bracket and inner hitch mount (both sides). Install one locking hitch pin (Item 2) [Figure 25] to secure the hitch to the main frame.

Installing The Leveling Crank Assembly

Figure 26

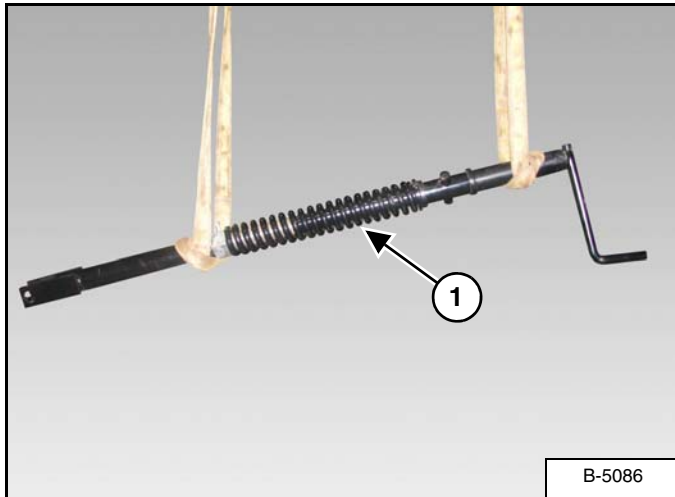

Locate the leveling crank assembly (Item 1) [Figure 26]. Install straps around the leveling crank assembly.

Connect the straps to an approved lifting device.

Raise and move the leveling crank assembly to the assembly area.

Figure 27

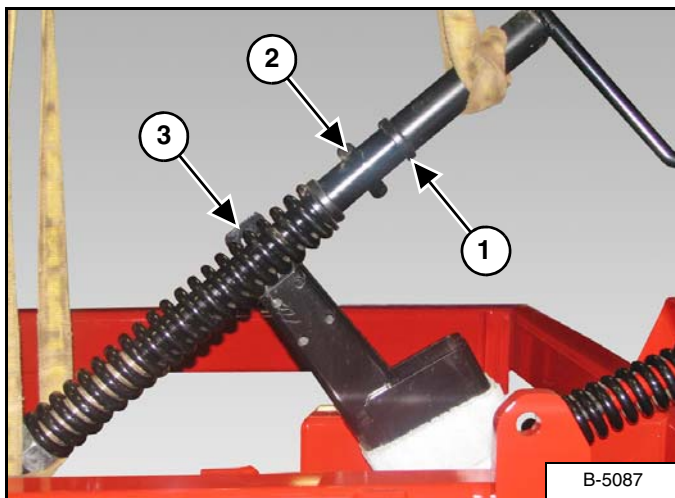

Lower the leveling crank assembly (Item 1) so lugs (Item 2) on trunion tube can be installed in hitch leveling arm lugs (Item 3) [Figure 27].

NOTE: Be sure grease fitting on trunion tube is facing up.

Figure 28

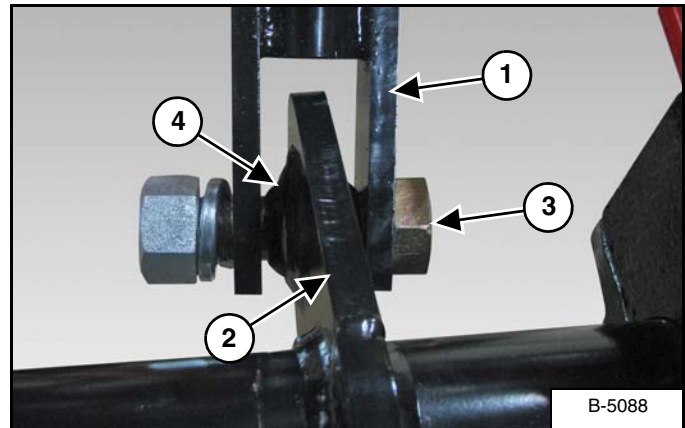

Position the clevis end (Item 1) of the leveling crank assembly over the connecting link (Item 2) [Figure 28] on the rockshaft (just left of center).

Lubricate ball in ball joint (Item 4) [Figure 28] so it can rotate freely.

Install one 1-1/4" x 4-3/4" bolt (Item 3) [Figure 28] through the clevis and connecting link. Install one 1-1/4" lock washer and nut on the bolt and tighten.

NOTE: Tighten bolt (Item 3) so it is tight against ball joint (Item 4) [Figure 28].

Figure 29

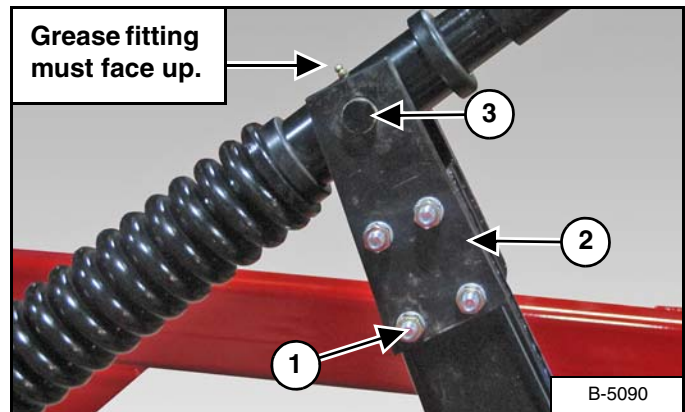

Locate four 1/2" x 5" Grade 5 bolts (Item 1), four 1/2" lock washers, four 1/2" nuts and the leveling lug hitch plate (Item 2) [Figure 29].

Install the leveling lug hitch plate onto the peg (Item 3) [Figure 29] of the leveling crank.

Install the four 1/2" x 5" Grade 5 bolts through the leveling lug hitch plate and leveling crank assembly. Install one 1/2" lock washer and 1/2" nut on each bolt and tighten.

Remove straps.

Installing The Gang Beams

NOTE: Support stands approximately 36 inches (914.4 mm) high are recommended when installing the gang beams onto the main frame.

NOTE: The following procedure shows the RH gang beam installation. The procedure is the same for the LH gang beam.

Gang Beam Identification

- Front Main Gang Beam - Long
- Rear Main Gang Beam - Short

Figure 30

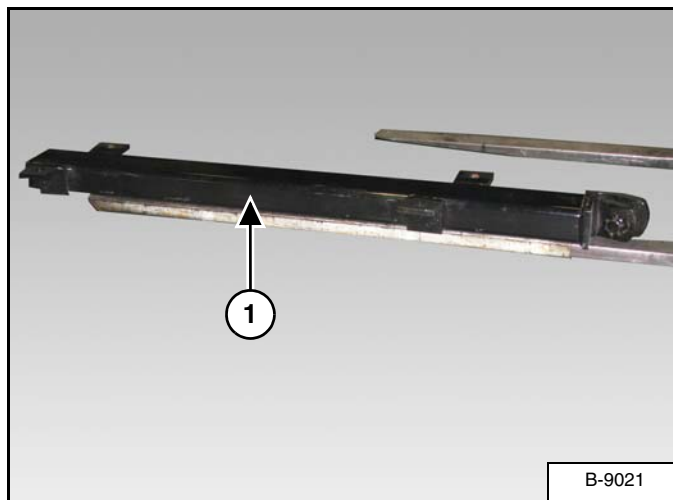

Locate RH front gang beam (Item 1) [Figure 30] (long).
Place the RH front gang beam on the fork of the forklift and move the RH front gang beam to the assembly area.

Figure 31

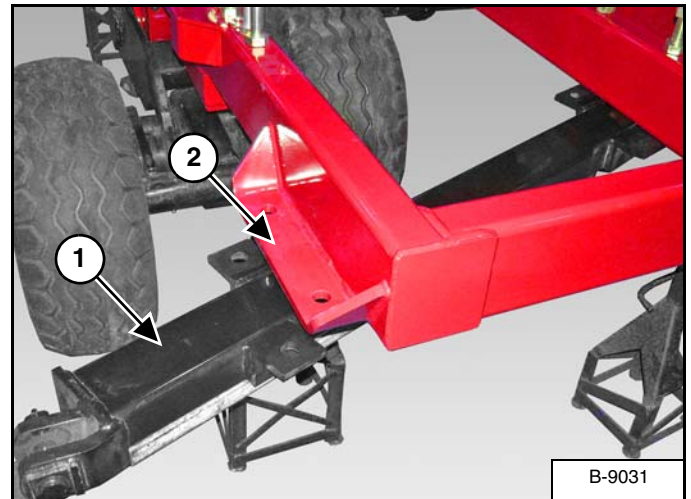

Align RH front gang beam (Item 1) with the mounts on the main frame assembly (Item 2) [Figure 31].

Figure 32

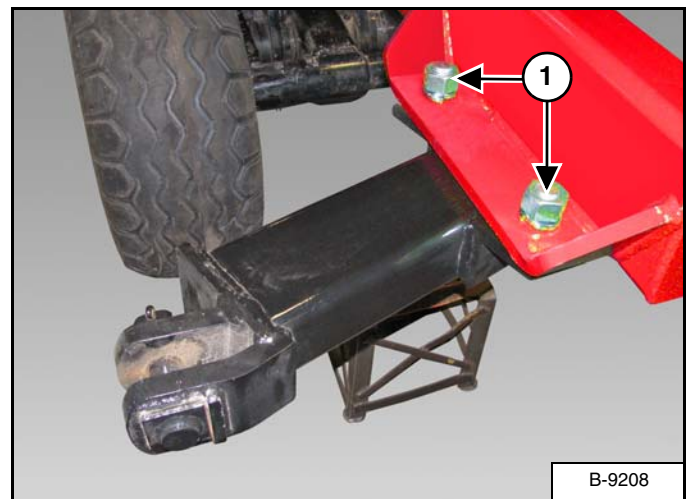

Locate four 1-1/4" x 3-1/2" bolts, 1-1/4 lock washers and 1-1/4 nuts (Item 1) [Figure 32].

Install the 1-1/4" x 3-1/2" bolts up through the gang beam flange and main frame mounting flange. Install one 1-1/4" lock washer and 1-1/4" nut on each bolt. Do not tighten at this time.

Repeat procedure for remaining gang beams.

Installing The Wing Gang Beams

NOTE: Support stands approximately 36 inches (914.4 mm) high are recommended when installing the wing gang beams onto the main frame.

NOTE: The following procedure shows the RH front wing gang beam installation. The procedure is the same for the remaining wing gang beams.

Figure 33

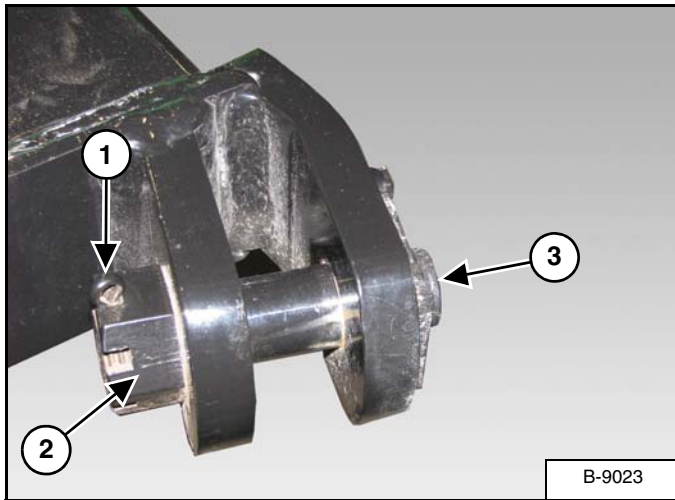

Remove cotter pin (Item 1), castle nut (Item 2) and wing hinge pin (Item 3) [Figure 33] from the RH front gang beam.

Figure 34

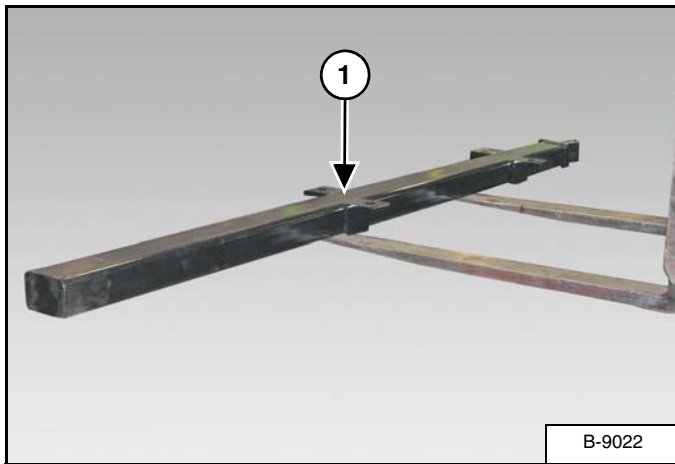

Locate RH wing gang beam (Item 1) [Figure 34].

Place the RH wing gang beam on the forks of the forklift and move the RH wing gang beam to the assembly area.

Figure 35

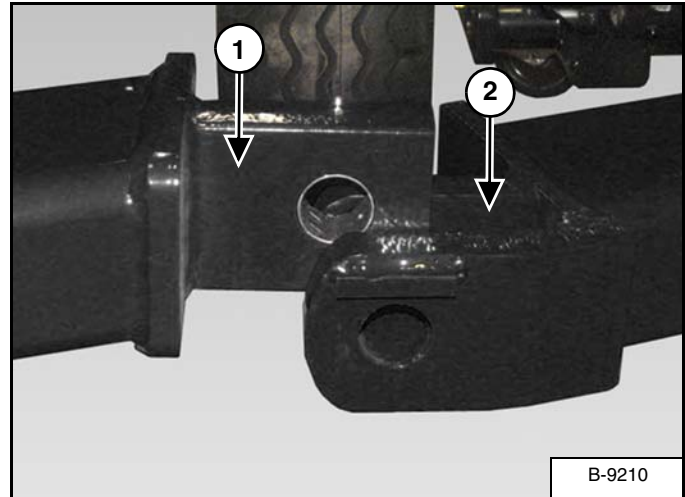

Align the RH wing gang beam (Item 1) with the RH front gang beam clevis (Item 2) [Figure 35].

Figure 36

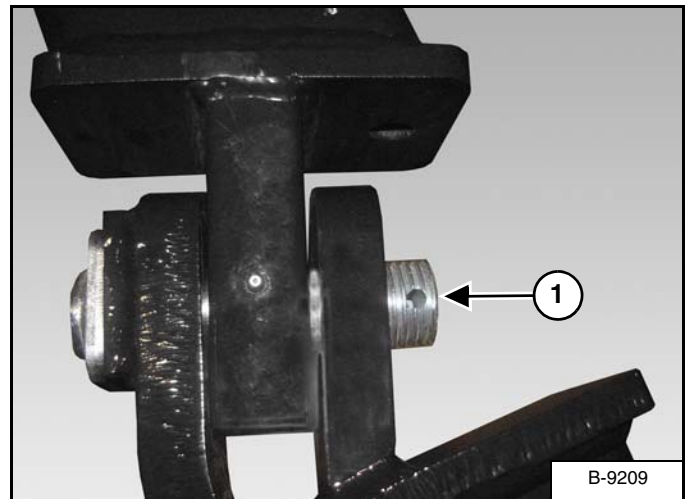

Locate two 1-1/2" wing hinge pins (Item 1) [Figure 36].
Install the wing hinge pin with cotter pin hole vertical (both locations).

Figure 37

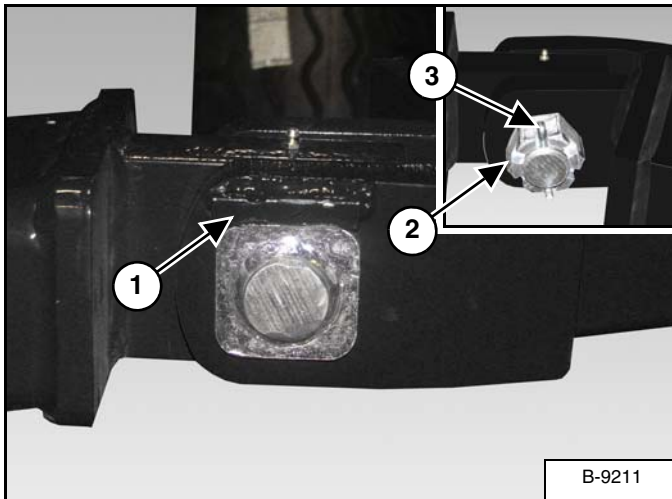

The wing hinge pin's square collar must be under the tab (Item 1) **[Figure 37]** to secure the wing hinge pin in position (all locations).

Install and tighten one 1-1/2" Grade 2 slotted nut (Item 2) against the main frame wing mount. Adjust slotted nut as needed to install the 5/16" x 2-1/4" cotter pin (Item 3) **[Figure 37]** (all locations).

Lower the RH wing gang beam onto the support stand.

Repeat for installing remaining wing gang beams.

Installing The Wing Frames

NOTE: Support stands approximately 36 inches (914.4 mm) high are recommended when installing the wing frames onto the main frame.

NOTE: The following procedure shows the RH wing frame installation. The procedure is the same for the LH wing frame.

Figure 38

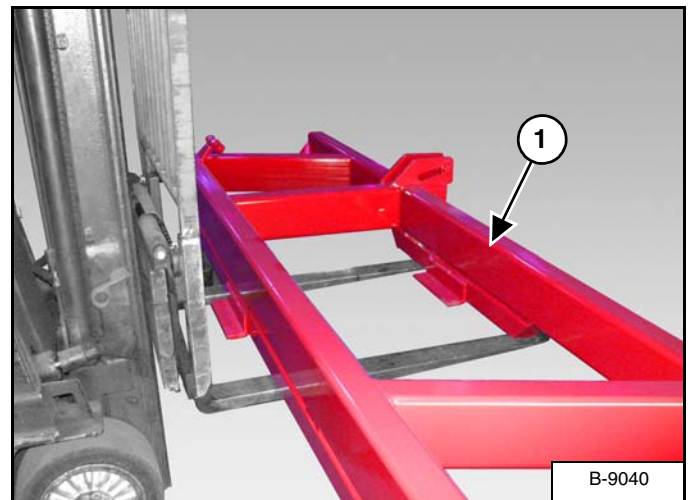

Using a forklift, position forks under the RH wing frame (Item 1) **[Figure 38]**.

Raise the RH wing frame and move to the assembly area.

Figure 39

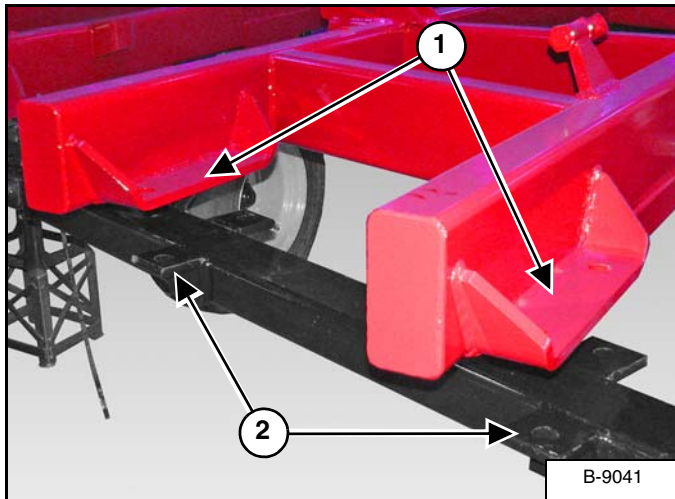

Move the RH wing frame towards the main frame and RH front and rear gang beams.

Align the RH wing mounting flanges (Item 1) with the gang beam mounting flanges (Item 2) [Figure 39] (front and rear locations).

Figure 40

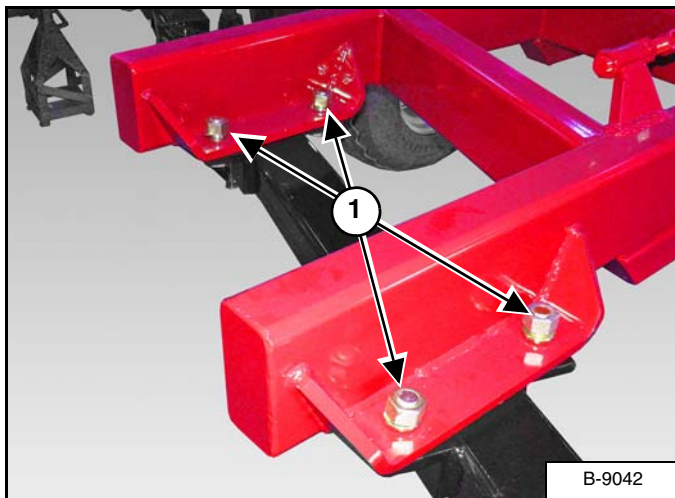

Locate eight 1-1/4" x 3-1/2" bolts, 1-1/4 lock washers and 1-1/4 nuts (Item 1) [Figure 40].

Install the 1-1/4" x 3-1/2" bolts up through the gang beam flange and main frame mounting flange. Install one 1-1/4" lock washer and 1-1/4" nut on each bolt. Do not tighten at this time.

Repeat procedure for LH wing frame.

Installing The Wing Rockshafts

Figure 41

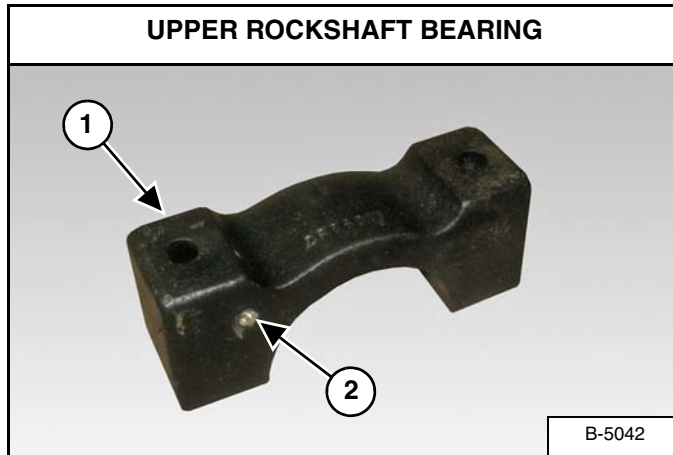

Locate the upper rockshaft bearings (Item 1) [Figure 41].

Locate and install grease fitting (Item 2) [Figure 41] (if required).

Apply thin layer of grease to rockshaft bearings.

! IMPORTANT

UPPER ROCKSHAFT BEARINGS

Always install the upper rockshaft bearings with the grease fitting on the same side as the tire attached.

Figure 42

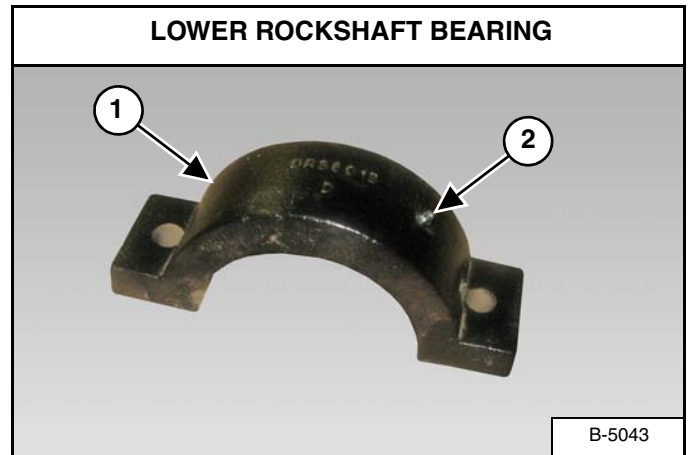

Locate the lower rockshaft bearings (Item 1) [Figure 42].

Locate and install grease fitting (Item 2) [Figure 42] (if required).

Apply thin layer of grease to rockshaft bearings.

! IMPORTANT

LOWER ROCKSHAFT BEARINGS

Always install the lower rockshaft bearings with the grease fitting opposite of the upper rockshaft bearing grease fitting.

Figure 43

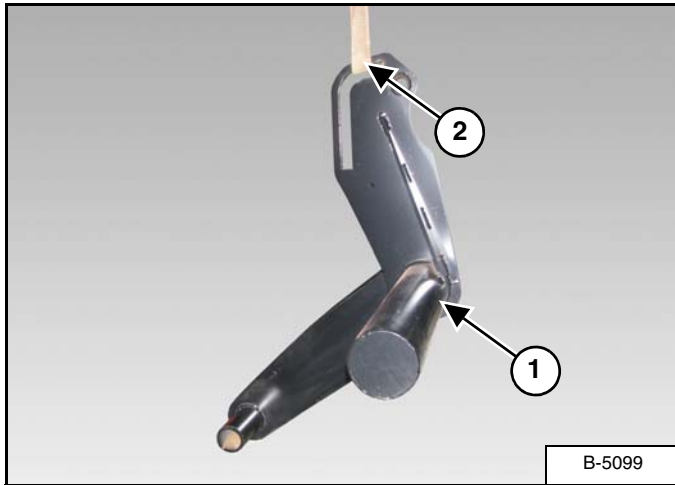

Locate RH wing rockshaft (Item 1). Install a strap (Item 2) [Figure 43] through the RH wing rockshaft.

Connect the straps to an approved lifting device.

Raise and move the RH wing rockshaft to the assembly area.

Figure 44

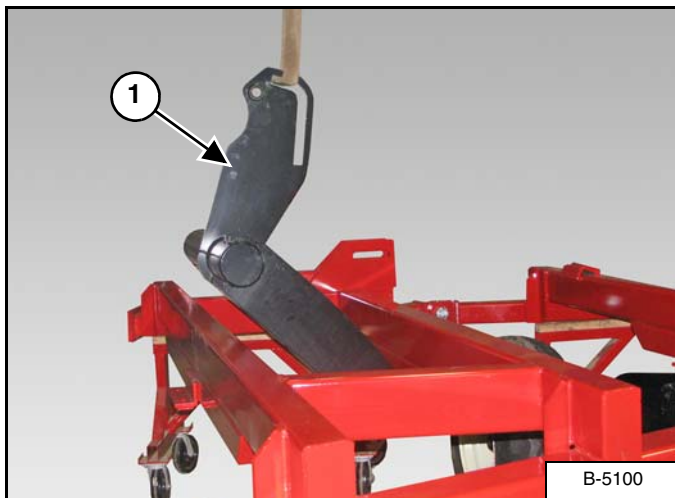

Lower the RH wing rockshaft (Item 1) [Figure 44] down through the outer opening in the wing frame.

Figure 45

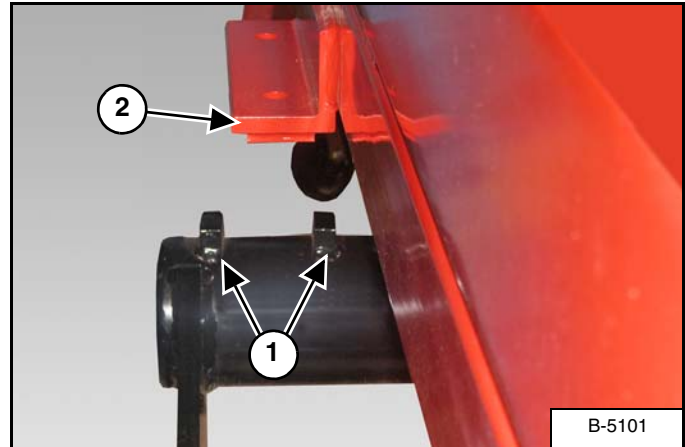

Rotate the RH wing rockshaft until the rockshaft legs are forward.

Adjust the rockshaft until the two tabs (Item 1) are centered under the rockshaft bearing mount (Item 2) [Figure 45].

Figure 46

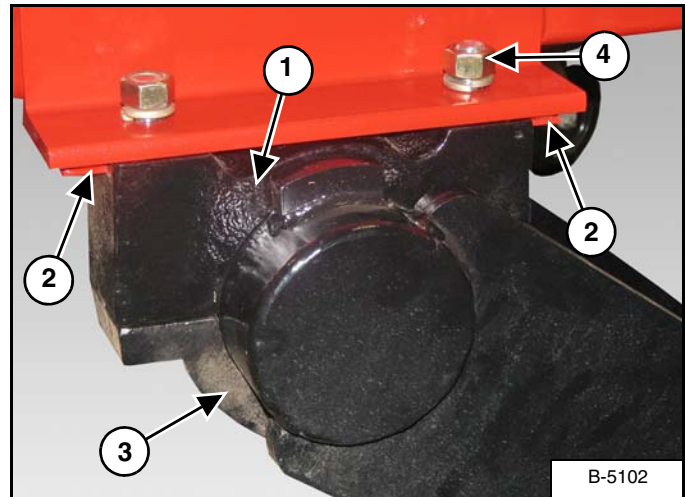

Place one upper rockshaft bearing (Item 1) [Figure 46] (grease fitting towards the FRONT) onto the rockshaft.

Raise the rockshaft, aligning the upper rockshaft bearing between the two tabs (Item 2) [Figure 46] on the rockshaft bearing mount. Continue raising the rockshaft until the upper bearing contacts the mount.

Align and install lower rockshaft bearing (Item 3) [Figure 46] (grease fitting facing towards the front).

Install two 3/4" x 6-1/2" Grade 5 bolts through the lower, upper rockshaft bearings and mount. Install one 3/4" lock washer and 3/4" nut (Item 4) [Figure 46] onto each bolt. Do not tighten at this time.

Figure 47

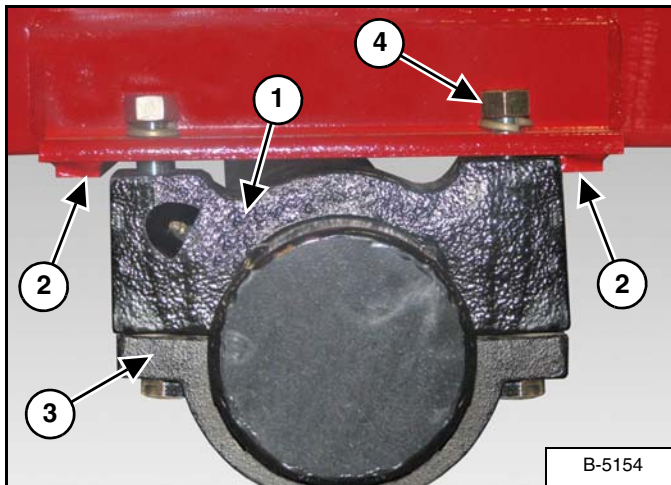

Place one upper rockshaft bearing (Item 1) [Figure 47] (grease fitting towards the front) onto the rockshaft.

Raise the rockshaft, aligning the upper rockshaft bearing between the two tabs (Item 2) [Figure 47] on the rockshaft bearing mount. Continue raising the rockshaft until the upper bearing contacts the mount.

Align and install lower rockshaft bearing (Item 3) [Figure 47] (grease fitting facing towards the rear).

Install two 3/4" x 6-1/2" Grade 5 bolts through the lower, upper rockshaft bearings and mount. Install one 3/4 lock washer and 3/4" nut (Item 4) [Figure 47] onto each bolt. Do not tighten at this time.

Figure 48

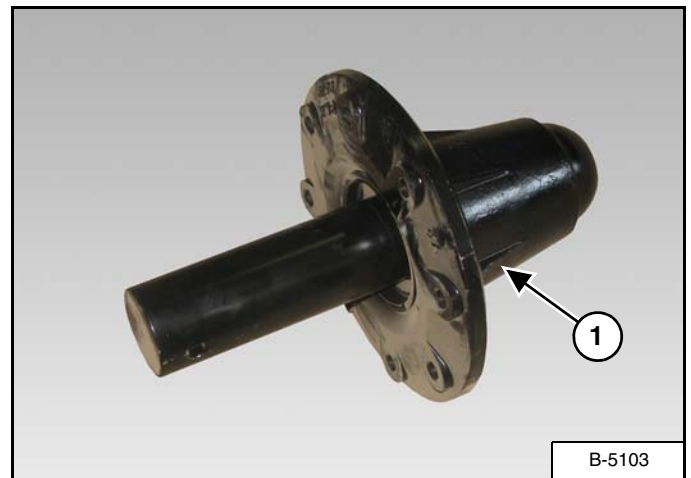

Locate two or four eight-bolt hub assemblies with (small) spindles (Item 1) [Figure 48].

Figure 49

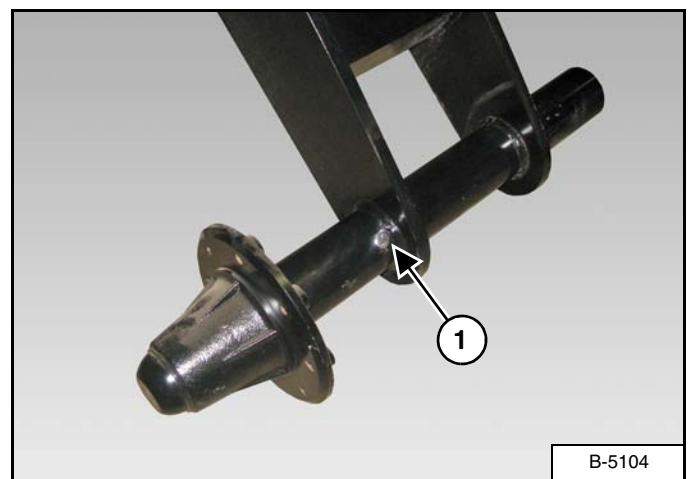

Insert one hub assembly into the outer mount tube at the bottom of the wing rockshaft (both sides).

Align spindle mounting hole with the outer mounting hole (Item 1) [Figure 49] of the mount tube (both sides).

Install one 1/2" x 4" Grade 5 bolt through the mount tube and spindle. Install one 1/2" lock nut on the bolt and tighten (both sides).

Figure 50

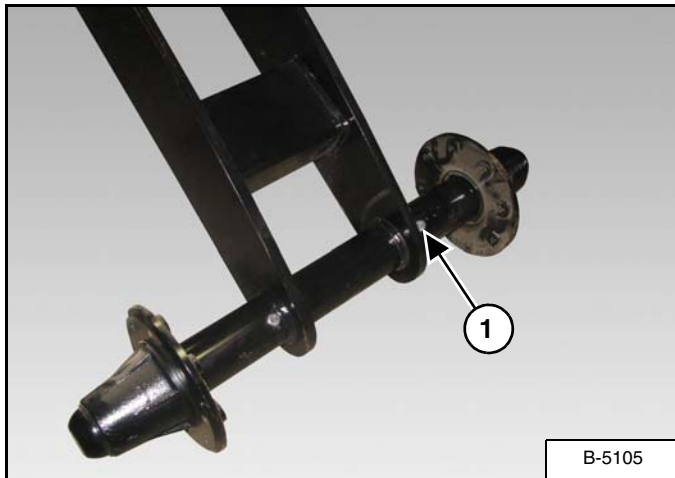

Insert another hub assembly (if required) into the inner mount tube at the bottom of the wing rockshaft (both sides).

Align second spindle (if required) mounting hole with the inner mounting hole (Item 1) **[Figure 50]** of the mount tube (both sides).

Install one 1/2" x 4" Grade 5 bolt through the mount tube and spindle. Install one 1/2" lock nut on the bolt and tighten (both sides).

Figure 51

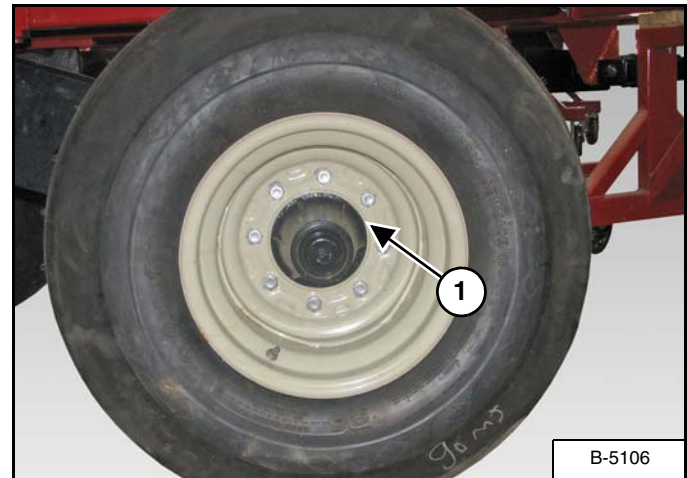

Tire Size 12.5L x 15 FI

Remove eight 9/16" NF x 1-1/4" wheel bolts from each hub.

Align wheel with the hub (Item 1) **[Figure 51]**. Reinstall the eight 9/16" NF x 1-1/4" wheel bolts (both wheels).

Tighten wheel bolts in a criss-cross pattern to 130 ft.-lb. (176.3 N•m) torque.

HYDRAULICS

Installing Main Frame Rockshaft Hydraulic Cylinder

NOTE: See the following for disc cylinder configuration to determine cylinder size per Tandem Disc model.

See pages 53 for 21.25" Frame Tandem Disc.

See pages 54 for 38.5" Frame Tandem Disc.

See pages 55 for 80.625" Frame Tandem Disc.



AVOID INJURY OR DEATH

Wear safety glasses to prevent eye injury when any of the following conditions exist:

- When fluids are under pressure.
- Flying debris or loose material is present.
- Engine is running.
- Tools are being used.



Fluid such as engine oil, hydraulic fluid, coolants, grease, etc. must be disposed of in an environmentally safe manner. Some regulations require that certain spills and leaks on the ground must be cleaned in a specific manner. See local, state and federal regulations for the correct disposal.

Figure 52

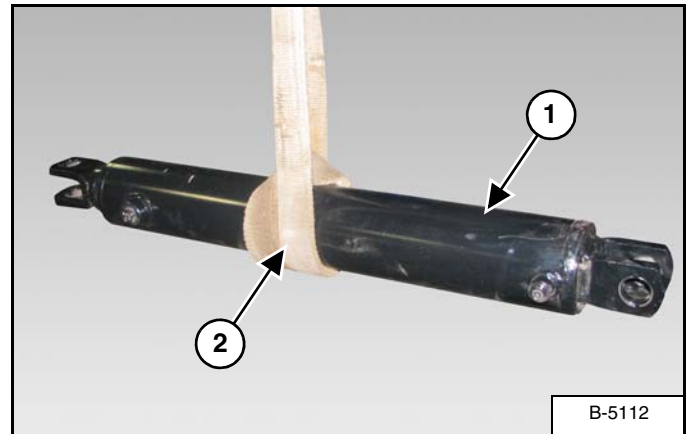

Locate one 4" x 24" or 4-1/2" x 24" hydraulic cylinder (Item 1) [Figure 52] (depending disc model).

Install a strap (Item 2) [Figure 52] around the hydraulic cylinder.

Connect the strap to an approved lifting device.

Raise and move the hydraulic cylinder to the assembly area.

Figure 53

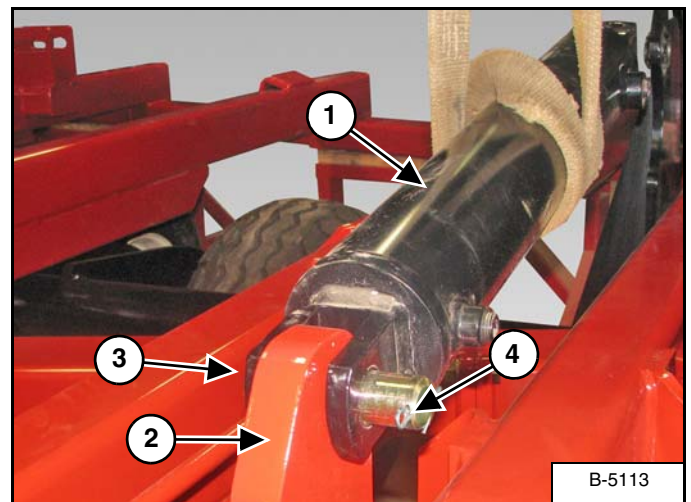

Align the 4" x 24" or 4-1/2" x 24" hydraulic cylinder (Item 1) with the mount (Item 2) [Figure 53] (ports facing left) at the front of the LH main frame.

Apply thin coat of grease to mount hole.

Locate and install one cylinder pin (Item 3) through the wing lift hydraulic cylinder and mount. Install one 5/16" x 1-3/4" cotter pin (Item 4) [Figure 53].

Figure 54

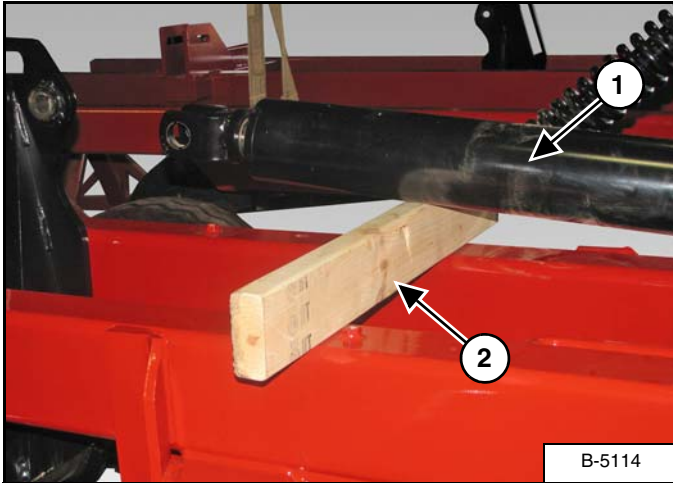

Lower the 4" x 24" hydraulic cylinder (Item 1) onto a block (Item 2) [Figure 54].

Remove strap.

Figure 55

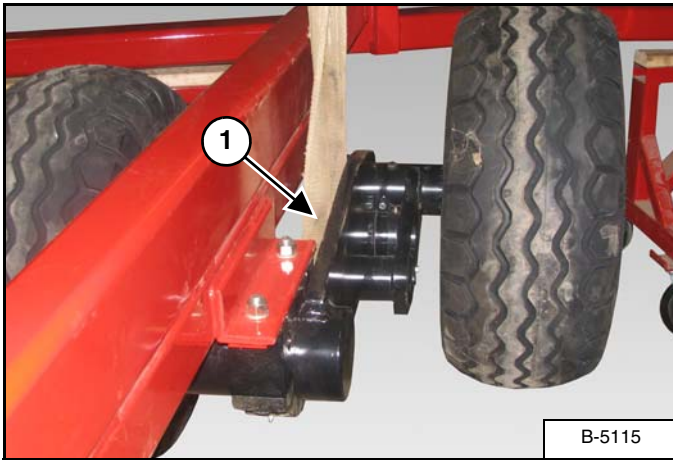

Install a strap (Item 1) [Figure 55] around the main frame rockshaft.

Connect the strap to an approved lifting device.

Figure 56

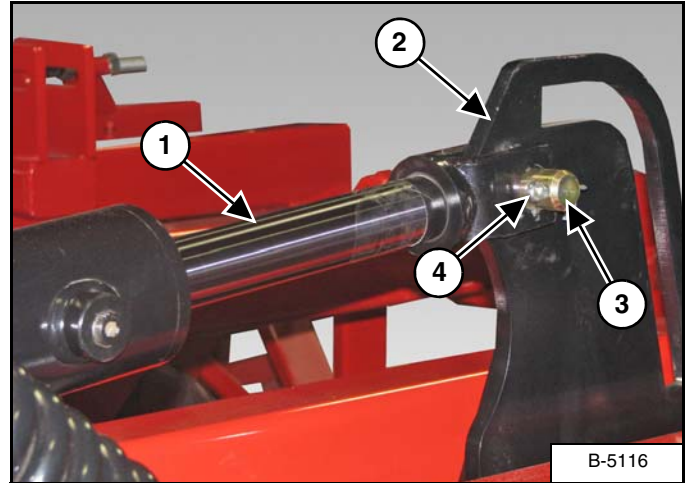

Loosen port plugs to allow the cylinder rod to be extended.

Raise the main frame rockshaft, extend the hydraulic cylinder rod (Item 1) towards the rockshaft mounting bracket (Item 2) [Figure 56].

Align clevis with the hole in the rockshaft mounting bracket. Install cylinder pin (Item 3) through the clevis and rockshaft mounting bracket. Install one 5/16" x 1-3/4" cotter pin (Item 4) [Figure 56].

Remove block, lower main frame rockshaft until wheels contact the ground. Remove the strap.

Apply thin layer of grease to spring bushing in rockshaft arm.

Installing Wing Lift Cylinders

Wing Lift Hydraulic Cylinder Size

5" x 36"

Place the wing lift cylinder on the forks of the forklift.

Raise and move the wing lift cylinder to the assembly area.

Figure 57

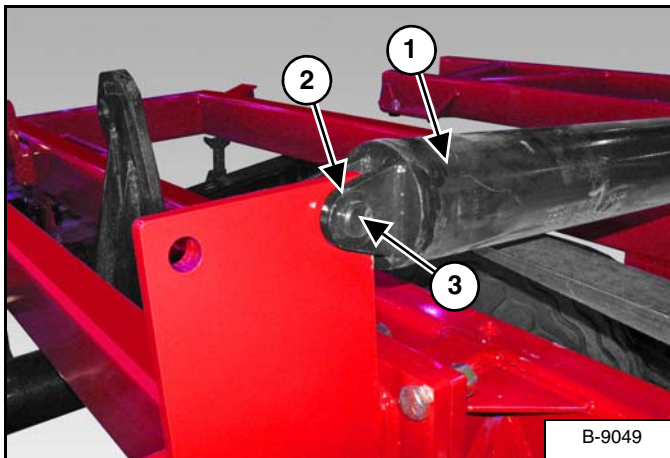

Align RH wing lift cylinder (Item 1) (ports facing forward) with the right hole on the mounting plate (Item 2) [Figure 57] located at the rear of the LH main frame.

Install one cylinder pin (Item 3) [Figure 57] through the RH wing lift cylinder and mounting plate. Install one 5/16" x 1-3/4" cotter pin.

Figure 58

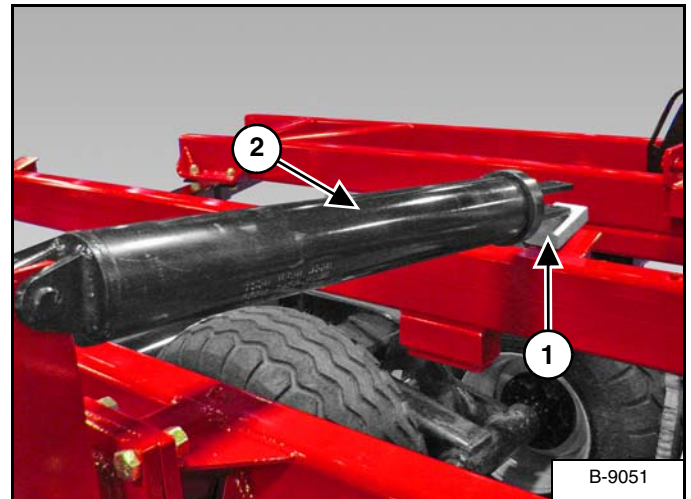

Place a block (Item 1) under the RH wing lift cylinder (Item 2) [Figure 58].

Lower RH wing lift cylinder onto the block and remove strap.

Repeat procedure for LH wing lift cylinder.

Installing Wing Rockshaft Hydraulic Cylinders

NOTE: See the following for disc cylinder configuration to determine cylinder size per Tandem Disc model.

See pages 53 for 21.25" Frame Tandem Disc.

See pages 54 for 38.5" Frame Tandem Disc.

See pages 55 for 80.625" Frame Tandem Disc.

Figure 59

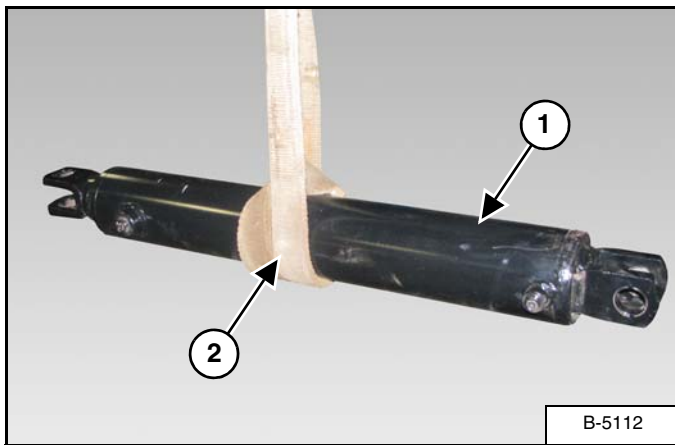

Locate one 3" x 24" or 3-1/2" x 24" hydraulic cylinder (Item 1) [Figure 59].

Install a strap (Item 2) [Figure 59] around the hydraulic cylinder.

Connect the strap to an approved lifting device.

Raise and move the hydraulic cylinder to the assembly area.

Figure 60

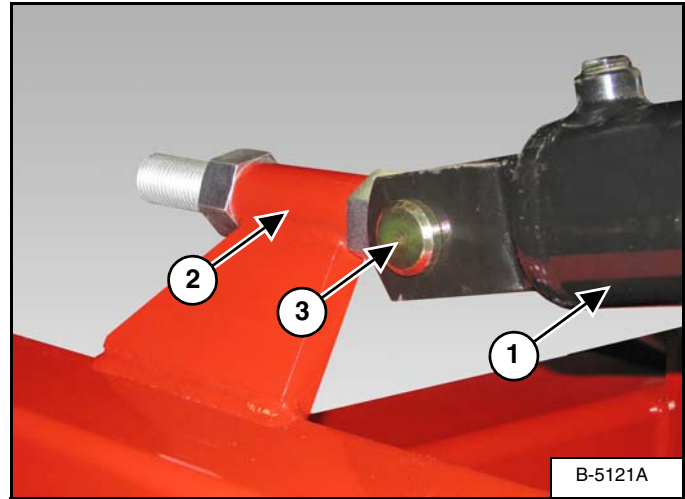

Align RH wing rockshaft cylinder (Item 1) (ports facing up) with the RH wing mounting bracket & eye-bolt rod (Item 2) [Figure 60].

Install one cylinder pin (Item 3) [Figure 60] through the RH wing lift cylinder and mounting plate. Install one 5/16" x 1-3/4" cotter pin.

Figure 61

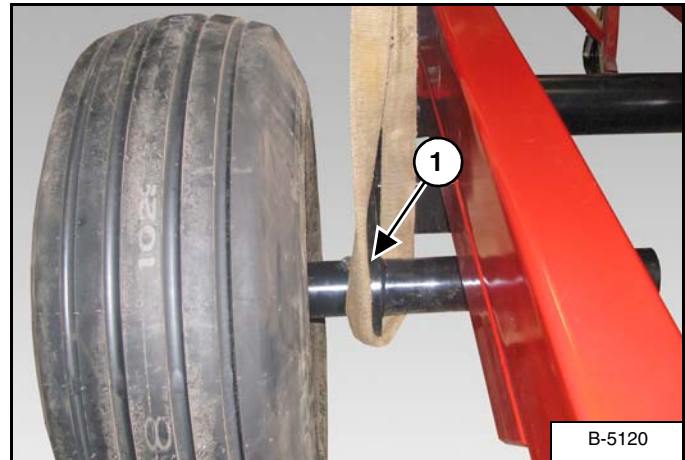

Install a strap (Item 1) [Figure 61] around the RH wing rockshaft.

Figure 62

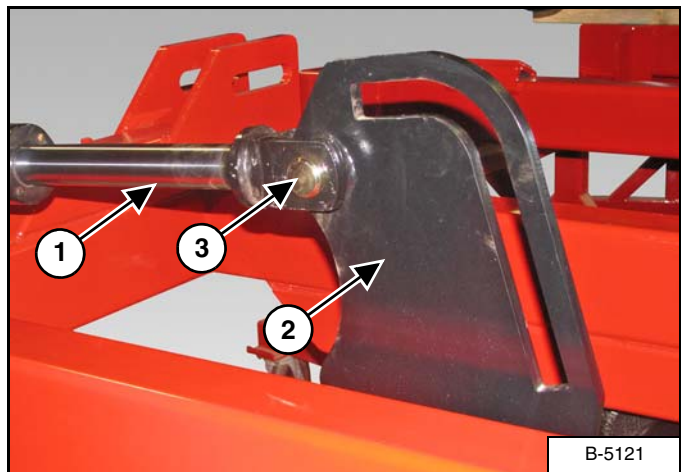

Loosen port plugs to allow the cylinder rod to be extended.

Raise the RH wing rockshaft, extend the hydraulic cylinder rod (Item 1) towards the rockshaft mounting bracket (Item 2) [Figure 62].

Align clevis with the hole in the rockshaft mounting bracket. Install cylinder pin (Item 3) [Figure 62] through the clevis and rockshaft mounting bracket. Install one 5/16" x 1-3/4" cotter pin.

Lower RH wing rockshaft until wheels contact the ground. Remove the strap.

Repeat procedure for LH 3-1/2" x 24" or 4" x 24" wing rockshaft hydraulic cylinder.

Apply thin layer of grease to spring bushing in rockshaft arm.

Installing Hydraulic Control Valves

Figure 63

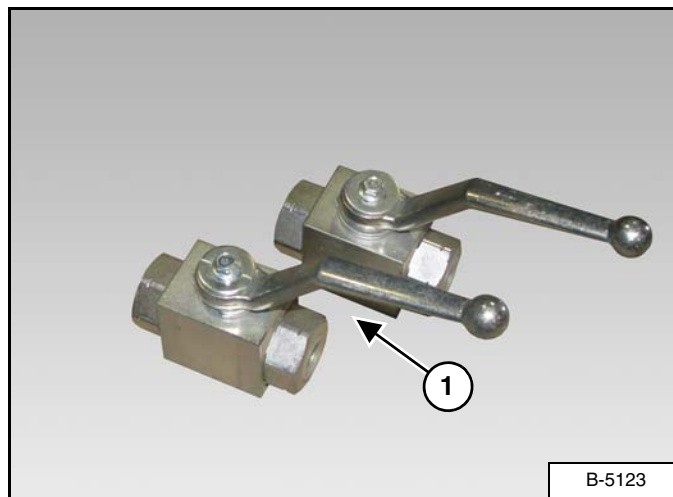

Locate the two 3/8" 2-way ball valves (Item 1) [Figure 63], two 5/16" x 4" Grade 5 bolts and two 5/16" lock nuts.

Rotate each ball valve lever 1/4 turn as shown in [Figure 63].

Figure 64

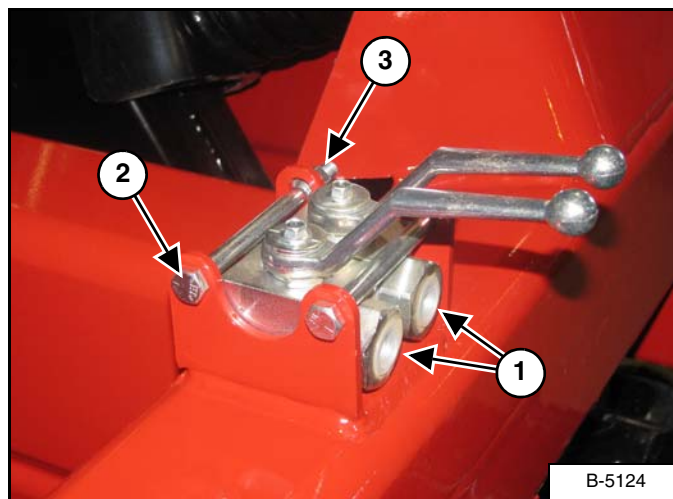

Position the two balls valves (Item 1) [Figure 64] (levers facing forward) between the two mounting brackets on the front of LH main frame.

Install the two 5/16" x 4" Grade 5 bolts (Item 2) through the mounting brackets (over the ball valves). Install one 5/16" lock nut (Item 3) [Figure 64] on each bolt and tighten. Do not over tighten.

Installing Hydraulic Fittings

NOTE: The following may not show your tandem disc exactly as it appears but the procedure is correct for all 8700 tandem discs.

Control Valve Fittings

Figure 65

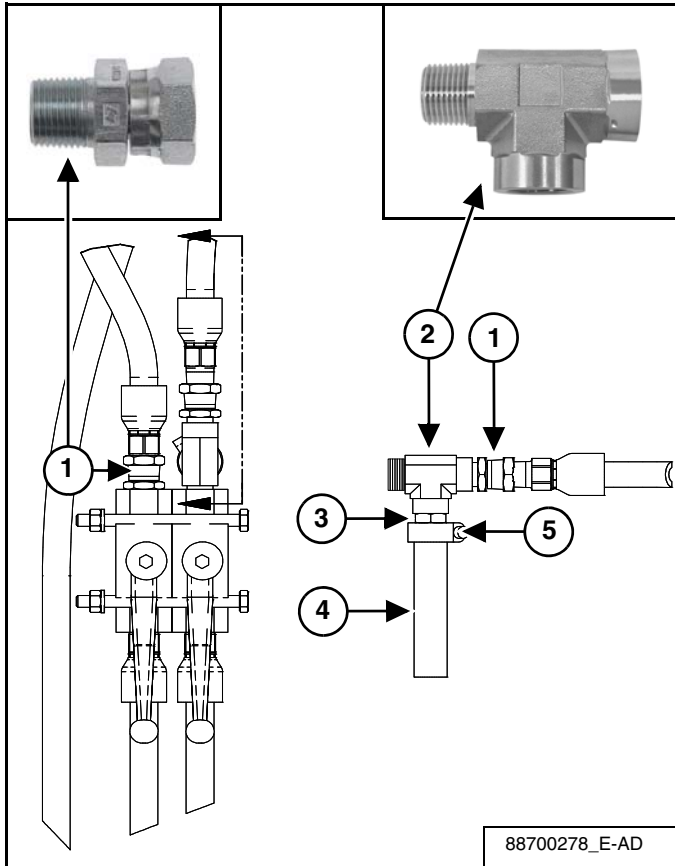

Locate two 3/8" male-female swivel fittings (Item 1) and one 3/8" NPTF run tee (Item 2) [Figure 65].

Apply thread sealant to the fittings.

NOTE: Do not use teflon tape.

Install the one 3/8" male-female swivel fitting (Item 1) [Figure 65] (facing the rear of the disc) into the RH ball valve.

Install the 3/8" NPTF run tee (Item 1) [Figure 65] (facing the rear of the disc) into the LH ball valve. Install one 3/8" male-female swivel fitting (Item 1) into the 3/8" NPTF run tee.

Install one 4500 PSI check valve (Item 3) into the 3/8" NPTF run tee.

Install one drain hose (Item 4) onto the 4500 PSI check valve (Item 6) and secure with one hose clamp (Item 5) [Figure 65].

Wing Rockshaft Cylinder Fittings

Figure 66

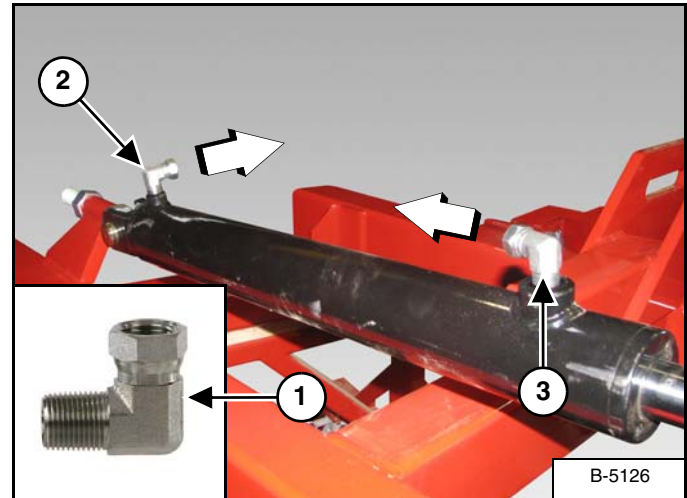

Locate four 90° 1/2" swivel street elbows (Item 1) [Figure 66].

Apply thread sealant to the two fittings.

Install the rear fitting (Item 2) [Figure 66] and tighten until the fitting is facing the center.

Install the front fitting (Item 3) [Figure 66] and tighten until the fitting is facing the rear fitting.

Repeat procedure for LH wing rockshaft cylinder.

Wing Lift Cylinder Fittings

Figure 67

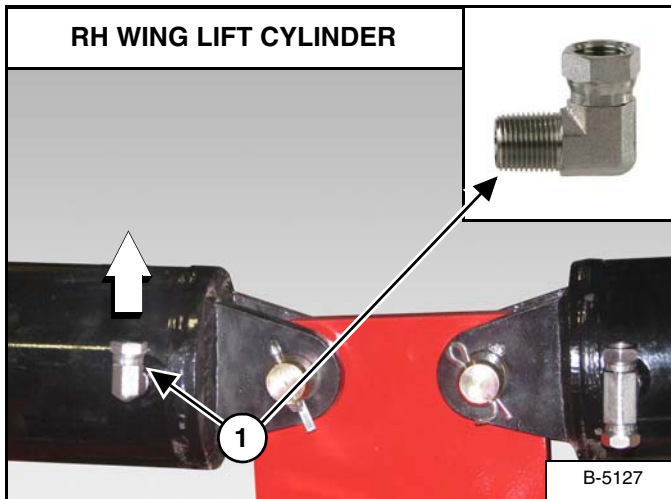

Locate one 90° 3/8" swivel street elbow (Item 1) [Figure 67].

Apply thread sealant to the fitting.

Install the rear fitting and tighten until the fitting is facing up.

Figure 68

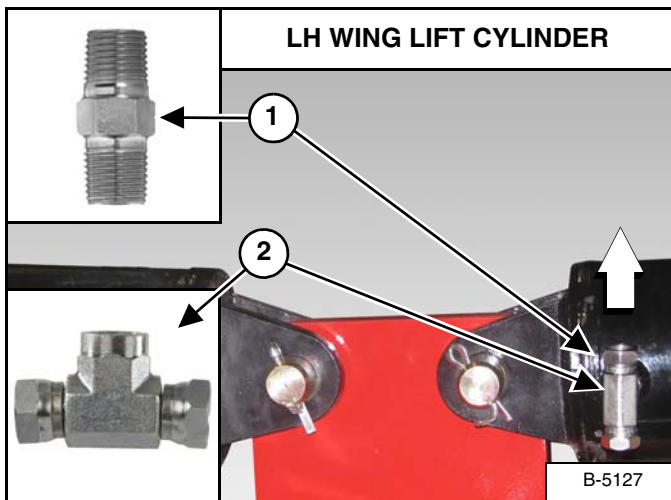

Locate one 3/8" close nipple (Item 1) and one 3/8" x 3/8" x 3/8" swivel tee (Item 2) [Figure 68].

Apply thread sealant to both ends of the close nipple.

Install the close nipple into the cylinder port, then install and tighten the swivel tee until facing vertical.

Figure 69

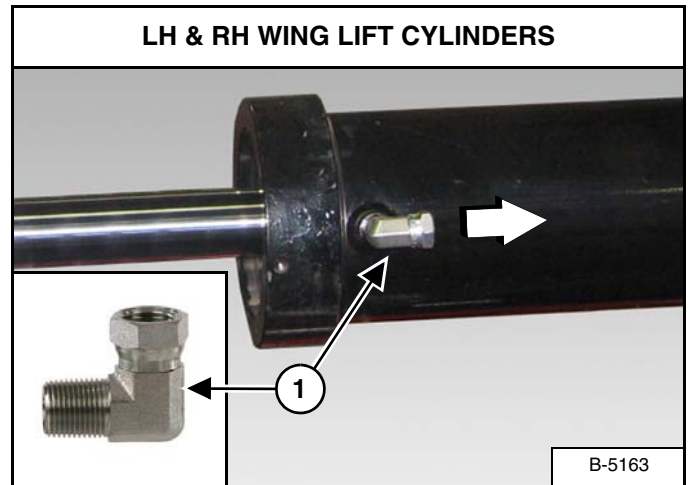

Locate two 90° 3/8" swivel street elbows (Item 1) [Figure 69].

Apply thread sealant to the two fittings.

Install one 90° 3/8" swivel street elbow (Item 1) [Figure 69] into the rod end of the RH wing lift cylinder, then tighten until the fitting is facing the center.

Repeat for LH wing lift cylinder.

Main Frame Rockshaft Lift Cylinder Fittings

Figure 70

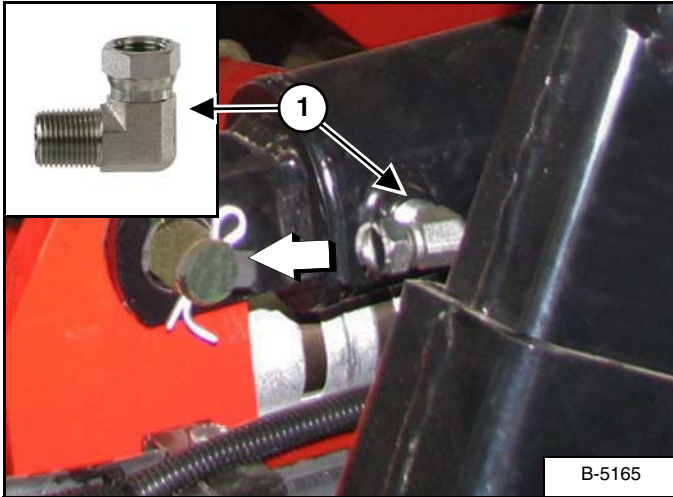

Locate one 90° 1/2" swivel street elbow (Item 1) [Figure 70].

Apply thread sealant to the fitting.

Install the 90° 1/2" swivel street elbow (Item 1) [Figure 70] into the base end of the main frame rockshaft lift cylinder, then tighten until the fitting is facing forward (slightly up).

Figure 71

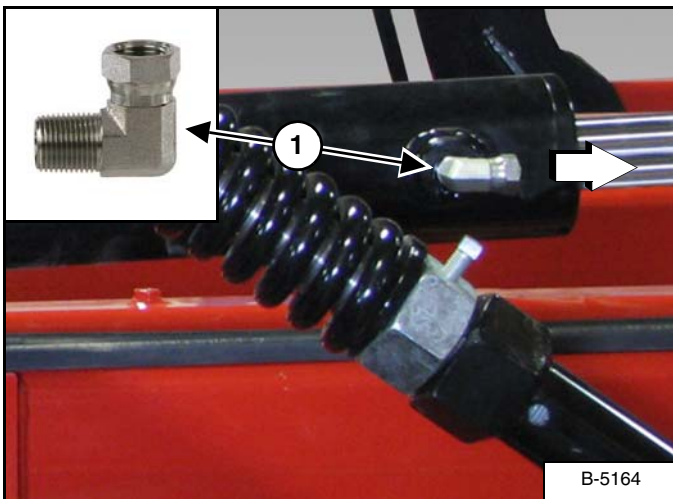

Locate one 90° 1/2" swivel street elbow (Item 1) [Figure 71].

Apply thread sealant to the fitting.

Install the 90° 1/2" swivel street elbow (Item 1) [Figure 71] into the rod end of the main frame rockshaft lift cylinder, then tighten until the fitting is facing to the rear.

Hydraulic Hose Identification - 21.25" Frame

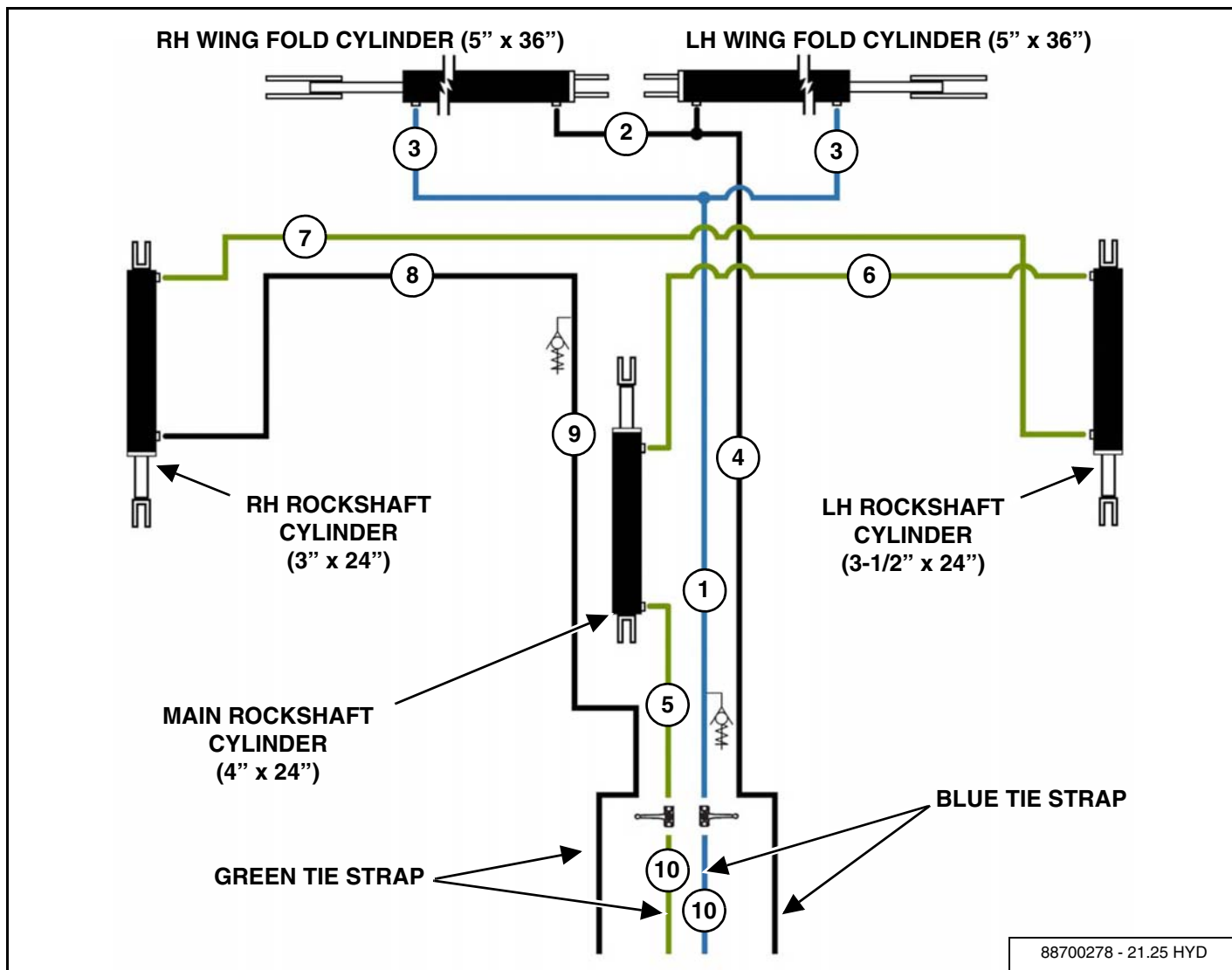

88700278 - 21.25 HYD

ITEM	DESCRIPTION	HOSE ROUTING	QTY
1	106" HOSE ASSEMBLY	From shut-off valve to swivel tee on wing cylinder (rod end)	1
2	24" HOSE ASSEMBLY	From swivel tee to base end of wing cylinder	1
3	54" HOSE ASSEMBLY	From RH wing cylinder rod end to swivel tee on LH wing cylinder rod end	2
4	287" HOSE ASSEMBLY	From tractor to swivel tee on wing cylinder (base end)	1
5	24" HOSE ASSEMBLY	From shut-off to main rockshaft cylinder (base end)	1
6	190" HOSE ASSEMBLY	From main rockshaft cylinder (rod end) to LH rockshaft cylinder (base end)	1
7	254" HOSE ASSEMBLY	From LH rockshaft cylinder (rod end) to RH rockshaft cylinder (base end)	1
8	131" HOSE ASSEMBLY	From RH rockshaft cylinder (rod end) to pressure relief valve	1
9	263" HOSE ASSEMBLY	From pressure relief valve to tractor	2
10	172" HOSE ASSEMBLY	From tractor to shut-off valve	2

Hydraulic Hose Identification - 38.5" Frame

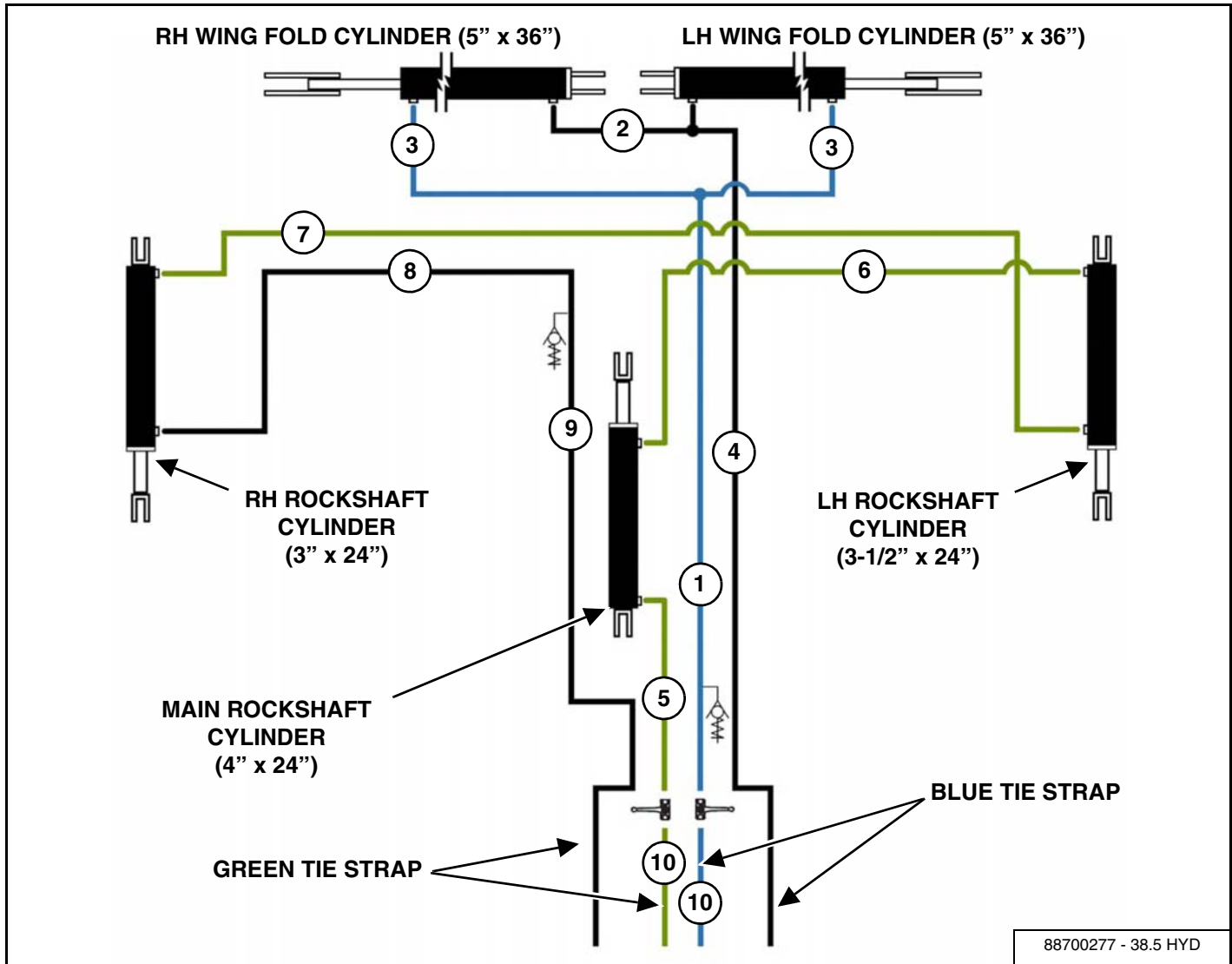

88700277 - 38.5 HYD

ITEM	DESCRIPTION	HOSE ROUTING	QTY
1	100" HOSE ASSEMBLY	From shut-off valve to swivel tee on wing cylinder (rod end)	1
2	24" HOSE ASSEMBLY	From RH wing cylinder rod end to swivel tee on LH wing cylinder rod end	1
3	54" HOSE ASSEMBLY	From swivel tee to base end of wing cylinder	2
4	294" HOSE ASSEMBLY	From tractor to swivel tee on wing cylinder (base end)	1
5	24" HOSE ASSEMBLY	From shut-off to main rockshaft cylinder (base end)	1
6	207" HOSE ASSEMBLY	From main rockshaft cylinder (rod end) to LH rockshaft cylinder (base end)	1
7	288" HOSE ASSEMBLY	From LH rockshaft cylinder (rod end) to RH rockshaft cylinder (base end)	1
8	163" HOSE ASSEMBLY	From RH rockshaft cylinder (rod end) to pressure relief valve	1
9	263" HOSE ASSEMBLY	From pressure relief valve to tractor	1
10	172" HOSE ASSEMBLY	From tractor to shut-off valve	2

Hydraulic Hose Identification - 80.625" Frame

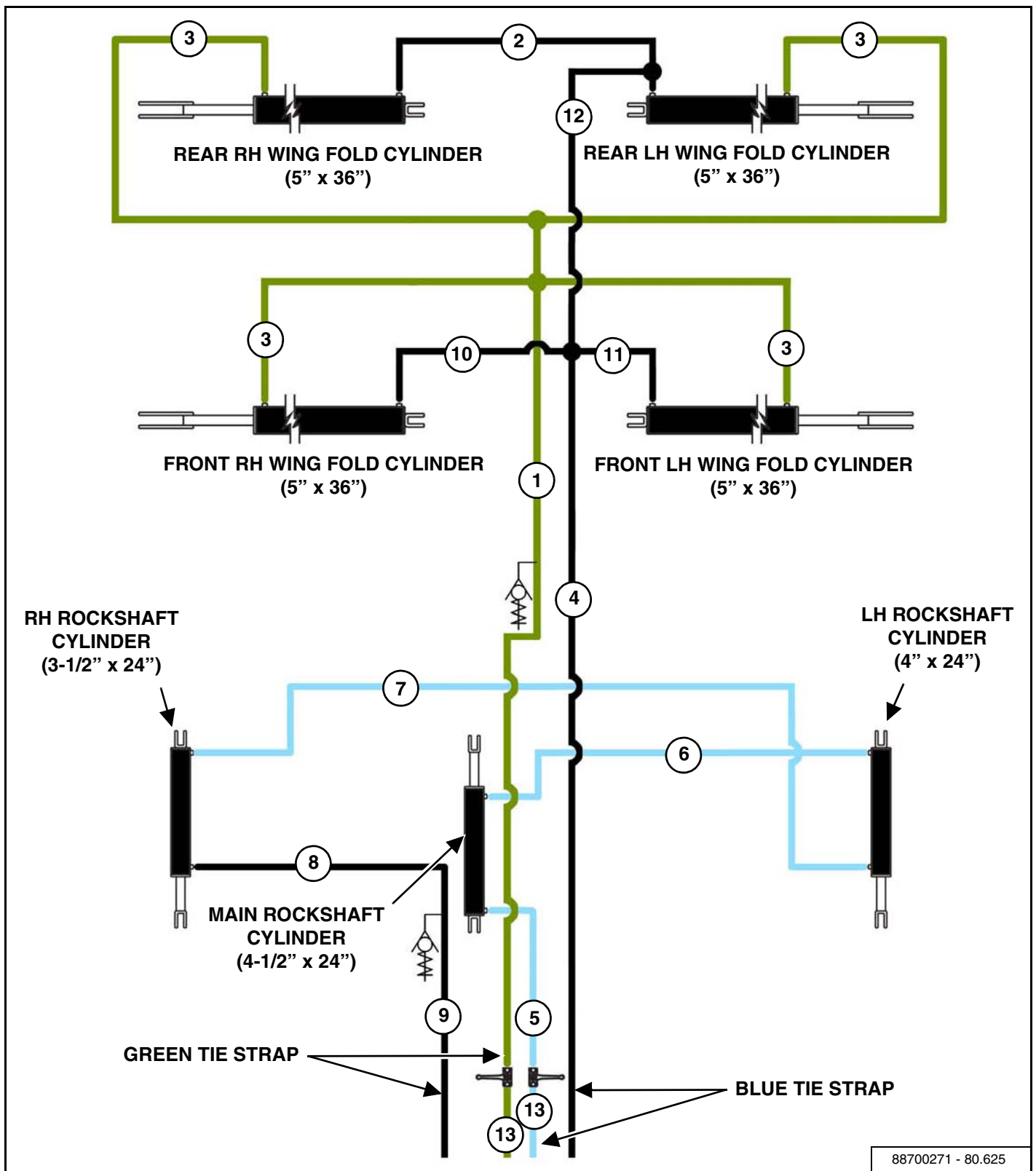

ITEM	DESCRIPTION	HOSE ROUTING	QTY
1	100" HOSE ASSEMBLY	From shut-off valve to swivel tee on wing cylinder (rod end)	1
2	24" HOSE ASSEMBLY	From RH wing cylinder rod end to swivel tee on LH wing cylinder rod end	1
3	54" HOSE ASSEMBLY	From swivel tee to base end of wing cylinder	2
4	178" HOSE ASSEMBLY	From tractor to union cross	1
5	24" HOSE ASSEMBLY	From shut-off to main rockshaft cylinder (base end)	1
6	253" HOSE ASSEMBLY	From main rockshaft cylinder (rod end) to LH rockshaft cylinder (base end)	1
7	410" HOSE ASSEMBLY	From LH rockshaft cylinder (rod end) to RH rockshaft cylinder (base end)	1
8	225" HOSE ASSEMBLY	From RH rockshaft cylinder (rod end) to pressure relief valve	1
9	263" HOSE ASSEMBLY	From pressure relief valve to tractor	2
10	30" HOSE ASSEMBLY	From front right wing cylinder (base end) to union cross	1
11	20" HOSE ASSEMBLY	From front left wing cylinder (base end) to union cross	1
12	100" HOSE ASSEMBLY	From union cross to swivel tee on wing cylinder (base end)	1
13	172" HOSE ASSEMBLY	From tractor to shut-off valve	2

Hydraulic Hose Installation And Routing



AVOID INJURY OR DEATH

Wear safety glasses to prevent eye injury when any of the following conditions exist:

- When fluids are under pressure.
- Flying debris or loose material is present.
- Engine is running.
- Tools are being used.



Fluid such as engine oil, hydraulic fluid, coolants, grease, etc. must be disposed of in an environmentally safe manner. Some regulations require that certain spills and leaks on the ground must be cleaned in a specific manner. See local, state and federal regulations for the correct disposal.



Apply thread sealant to the threads of all hydraulic hose fittings before installing.

Figure 72

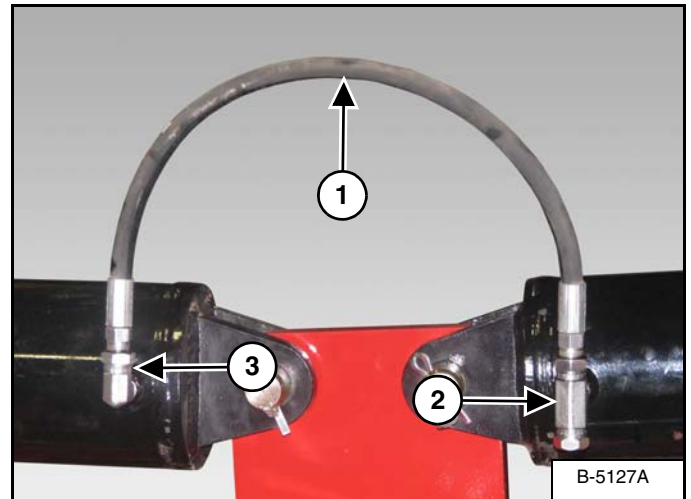

Install the 24" hydraulic hose (Item 1) from the top of the swivel tee (Item 2) on the LH wing cylinder to the 90° 3/8" street elbow (Item 3) [Figure 72] at the base end of the RH wing cylinder.

Figure 73

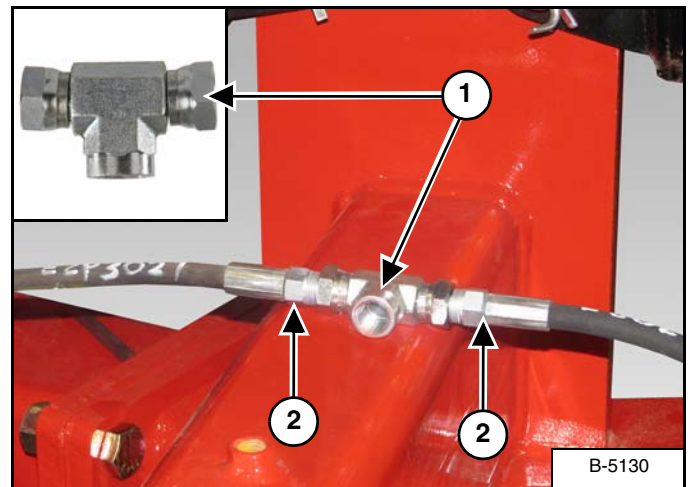

Locate one 3/8" swivel tee fitting (Item 1) [Figure 73].

Install one 54" hydraulic hose (Item 2) [Figure 73] into each end of the swivel tee.

Install the free end of the 54" hydraulic hoses to the 90° 3/8" street elbow at the rod end of the RH & LH wing cylinders.

*Main Rockshaft Cylinder To LH Rockshaft Cylinder
Connecting Hose Sizes*

- 190" Long - Super Narrow Models
- 207" Long - Narrow Wing Models
- 253" Long - Wide Wing Models

Figure 74

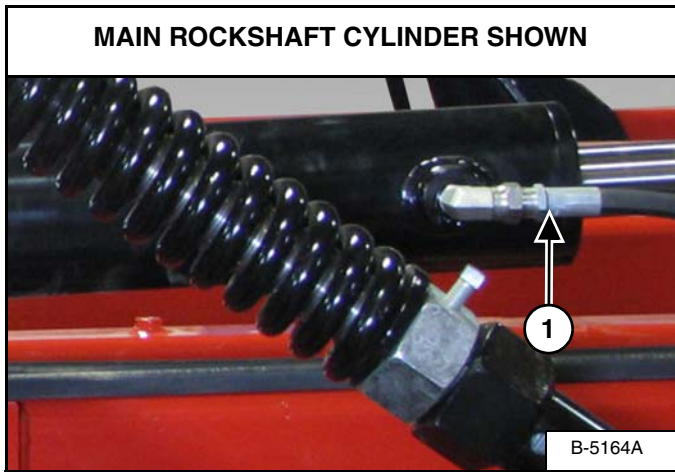

Install hydraulic hose (Item 1) [Figure 74] into the street elbow at the rod end of the main rockshaft cylinder. Route and install the hose into the street elbow at the base end of the LH rockshaft cylinder.

RH & LH Rockshaft Cylinder Connecting Hose Sizes

- 254" Long - Super Narrow Models
- 288" Long - Narrow Wing Models
- 410" Long - Wide Wing Models

Figure 75

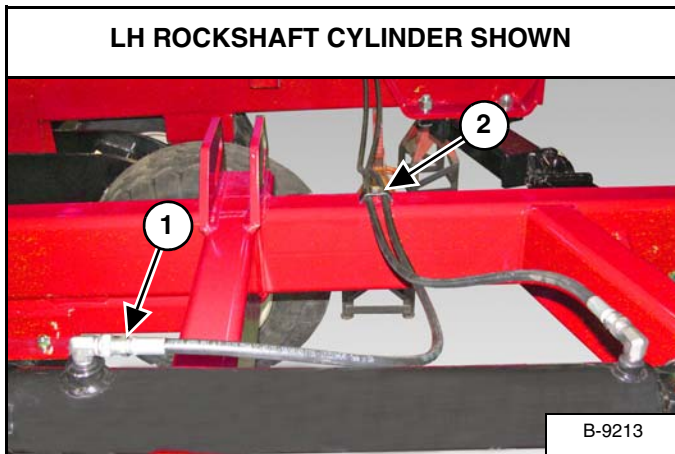

Install the hydraulic hose (Item 1) [Figure 75] into street elbow at the rod end of the LH rockshaft cylinder. Route and install the hose into the street elbow at the base end of the RH rockshaft cylinder.

RH Rockshaft Cylinder To Tractor Hose Sizes

- 401" Long - Super Narrow Models
- 418" Long - Narrow Wing Models
- 489" Long - Wide Wing Models

Locate one 2-line hose retainer (Item 2) [Figure 75], one 1/2" x 3/4" bolt and one 1/2" lock washer.

Place the 1/2" lock washer on the 1/2" bolt. Install the bolt through the 2-line hose retainer, position the two hoses inside the 2-line hose retainer, align bolt with the weld nut on the frame (as shown), install and tighten the bolt into the weld nut.

Figure 76

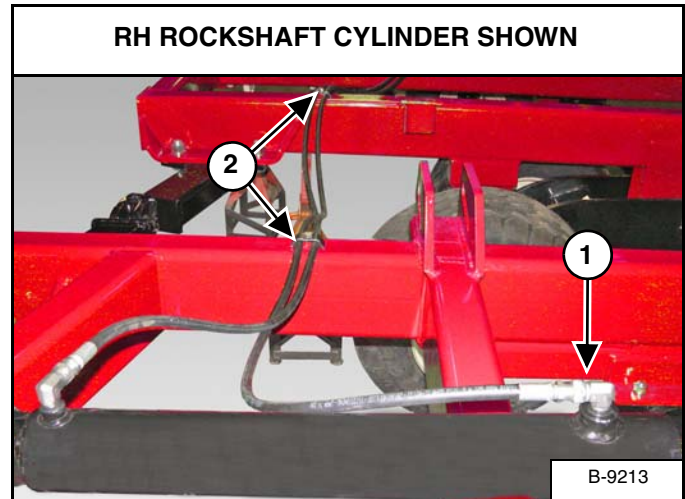

Install the 131" hydraulic hose (Item 1) [Figure 76] onto the street elbow at the rod end of the RH rockshaft cylinder. Route the hose along the rear of the machine to the center of the main frame.

Locate two 2-line hose retainers (Item 2) [Figure 76], two 1/2" x 3/4" bolts and two 1/2" lock washers.

Place one 1/2" lock washer on each 1/2" bolt. Install one bolt through each 2-line hose retainer, position the two hoses inside the 2-line hose retainers, align bolts with the weld nuts on the frame (as shown), install and tighten the bolts into the weld nuts.

Figure 77

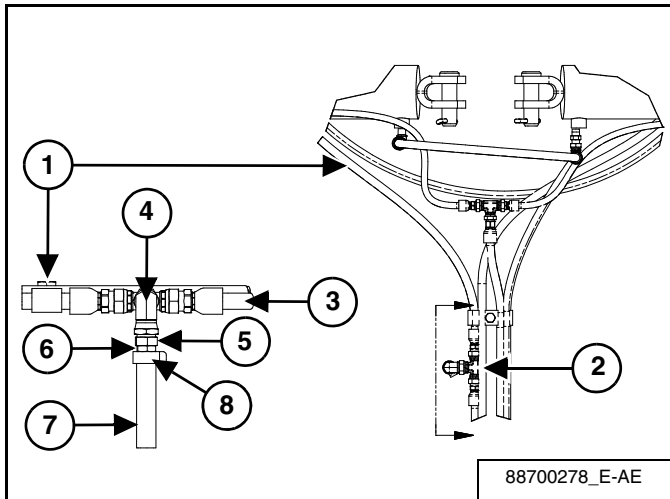

Install the 131" hydraulic hose (Item 1) onto the 1/2" FPX x 1/2" FPX x 1/2" FP swivel tee (Item 2) [Figure 77]. Install the 236" hydraulic hose (Item 3) onto the 1/2" FPX x 1/2" FPX x 1/2" FP swivel tee. Route the hose along the center of the main frame to the tractor.

Install one 1/2" 90° swivel elbow (Item 4) onto the 1/2" FPX x 1/2" FPX x 1/2" FP swivel tee (Item 2) [Figure 77].

Install a 1/2" x 3/8" reducer (Item 5) into 1/2" 90° swivel elbow (Item 4) [Figure 77].

Install one 4500 PSI check valve (Item 6) into the 1/2" x 3/8" reducer (Item 5) [Figure 77].

Install one drain hose (Item 7) onto the 4500 PSI check valve (Item 6) and secure with one hose clamp (Item 8) [Figure 77].

From Tractor To Swivel Tee Hose Sizes

- 287" Long - Super Narrow Models
- 294" Long - Narrow Wing Models
- 178" Long - Wide Wing Models

Figure 78

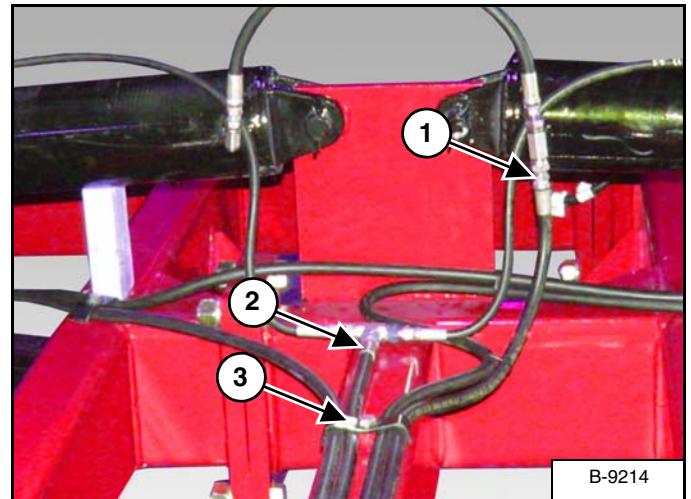

Install the hydraulic hose (Item 1) [Figure 78] into the bottom side of the swivel tee on the LH wing cylinder. Route the hose down the center of the machines frame and to the hitch / tractor.

Left Valve to Swivel Tee Connecting Hose Sizes

- 106" Long - Super Narrow Models
- 100" Long - Narrow Wing Models
- 100" Long - Wide Wing Models

Install the hydraulic hose (Item 2) [Figure 78] into the swivel tee (connected to the rod ends of the LH & RH wing cylinders). Route the hose down the center of the machine frame to the shut-off valves.

Locate one 4-line hose retainer (Item 3) [Figure 78], one 1/2" x 3/4" bolt and one 1/2" lock washer.

Place the 1/2" lock washer on the 1/2" bolt. Install the bolt through the 4-line hose retainer, position the four hoses inside the 4-line hose retainer, align bolt with the weld nut on the frame (as shown), install and tighten the bolt into the weld nut.

Figure 79

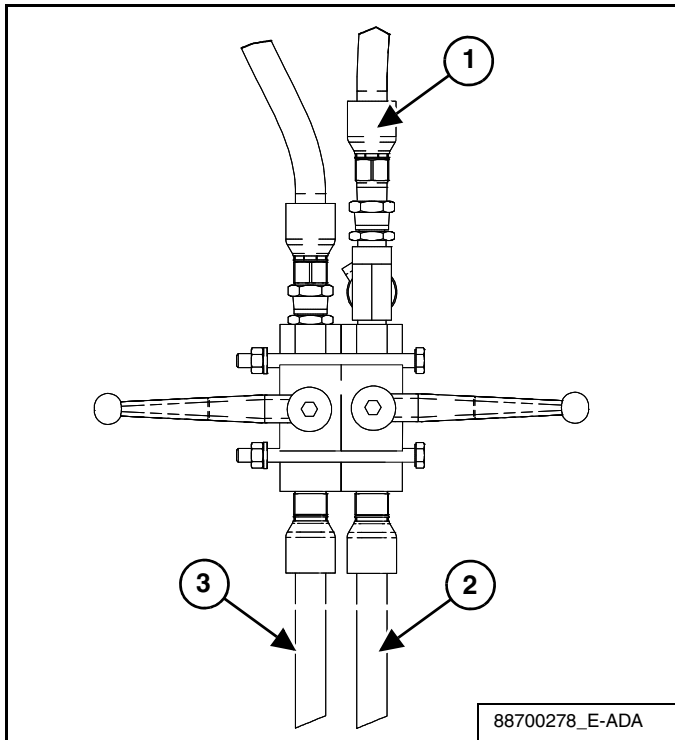

Install the hydraulic hose (Item 1) [Figure 79] (from swivel tee) into the 1/2" FPX x 1/2" FPX x 1/2" FP swivel tee.

Valve to Tractor Connecting Hose Sizes

- 172" Long - Super Narrow Models
- 172" Long - Narrow Wing Models
- 172" Long - Wide Wing Models

Install the one hydraulic hose (Item 2) [Figure 79] into the front side of the LH shut-off valve. Route the hose to the hitch / tractor (Blue tie strap).

Install the one hydraulic hose (Item 3) [Figure 79] into the front side of the RH shut-off valve. Route the hose to the hitch / tractor (Green tie strap).

Right Valve To Main Rockshaft Cylinder Connecting Hose Sizes

- 24" Long - Super Narrow Models
- 24" Long - Narrow Wing Models
- 24" Long - Wide Wing Models

Figure 80

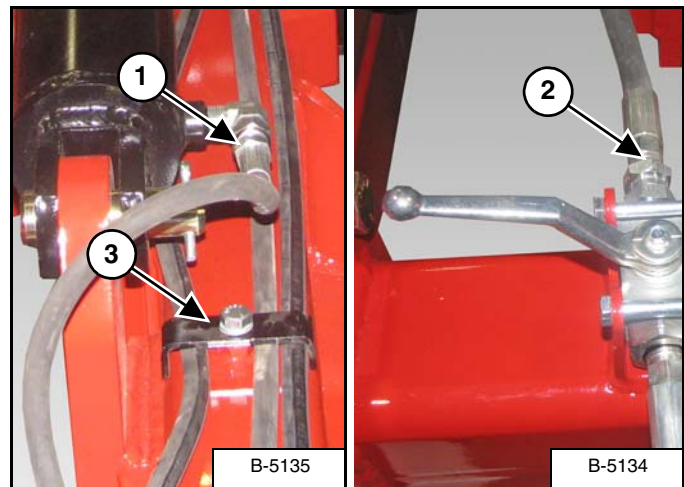

Install the hydraulic hose (Item 1) [Figure 80] into the street elbow at the base end of the main rockshaft cylinder. Route and install the hose to the RH shut-off valve (Item 2) [Figure 80].

Locate one 4-line hose retainer (Item 3) [Figure 80], one 1/2" x 3/4" bolt and one 1/2" lock washer.

Place the 1/2" lock washer on the 1/2" bolt. Install the bolt through the 4-line hose retainer, position the three hoses inside the 4-line hose retainer, align bolt with the weld nut on the frame (as shown), install and tighten the bolt into the weld nut.

Locate the remaining 2 and 4-line hose retainers, 1/2" x 3/4" bolts and 1/2" lock washers. Install the correct hose retainers at all weld nut locations to secure all hydraulic hoses to the machines frame.

Pressure And Return Hose Fittings

Figure 81

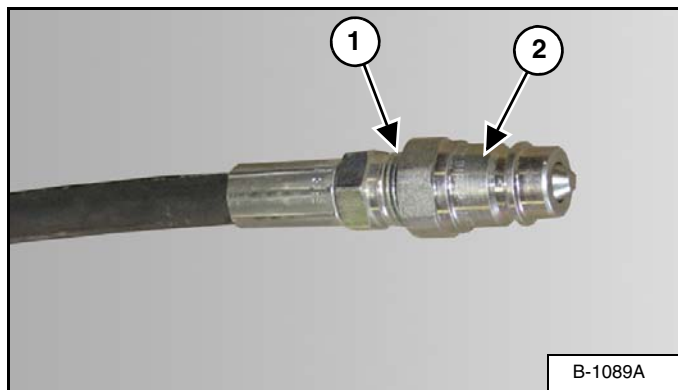

Apply thread sealant to the threads (Item 1) of the hydraulic hose fitting, then install and tighten the male quick coupler fitting (Item 2) [Figure 81] on each set of hydraulic hoses: wing fold hoses (Blue tie straps) and raise/lower hoses (Green tie straps).

Figure 82

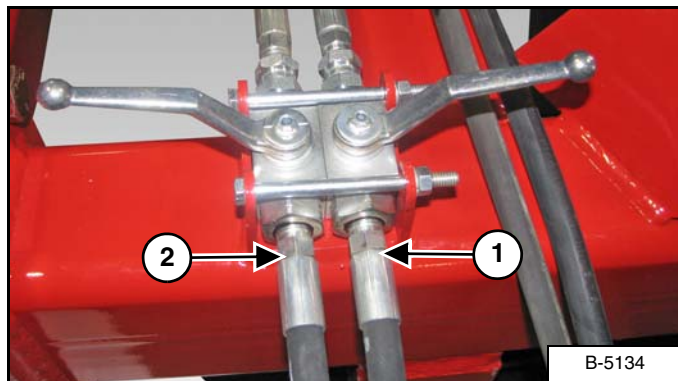

After installing the male quick coupler fittings, install the Blue and Green tie straps to identify the hydraulic circuits.

Blue Tie Straps (Wing Fold)

Install one Blue tie strap onto the hydraulic hose connected to the LH shut-off valve (Item 1) [Figure 82].

Install one Blue tie strap onto the hydraulic hose connected to the swivel tee at the base end of the LH wing cylinder.

Green Tie Straps (Raise / Lower)

Install one Green tie strap onto the hydraulic hose connected to the RH shut-off valve (Item 2) [Figure 82].

Install one Green tie strap onto the hydraulic hose connected to the swivel tee connecting the rod ends of the RH & LH wing cylinders.

Enter the tractor, start the engine and move the tractor in front of the tandem disc hitch. (See “Entering And Leaving The Operator’s Position” on page 93.)

Engage parking brake and exit the tractor.

Connect the hydraulic hoses to the tractor’s auxiliary hydraulics.

Figure 83

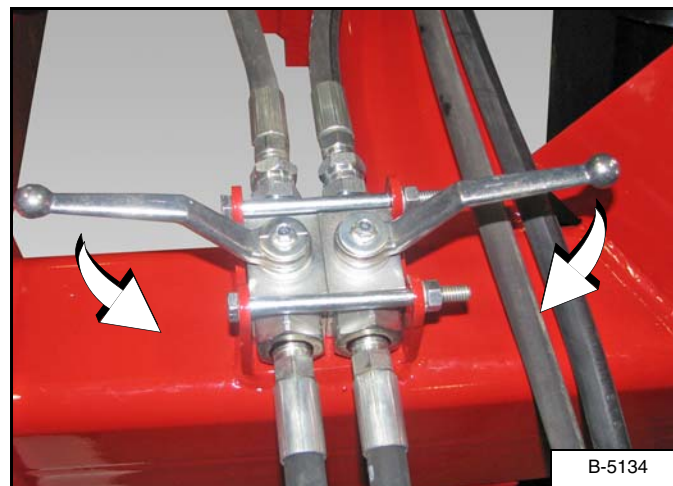

Open the two shut-off valves [Figure 83].

Enter the tractor and engage tractor auxiliary hydraulics. Using the tractor’s auxiliary controls, cycle the hydraulic cylinders on the tandem disc to remove all air from the system.

Figure 84

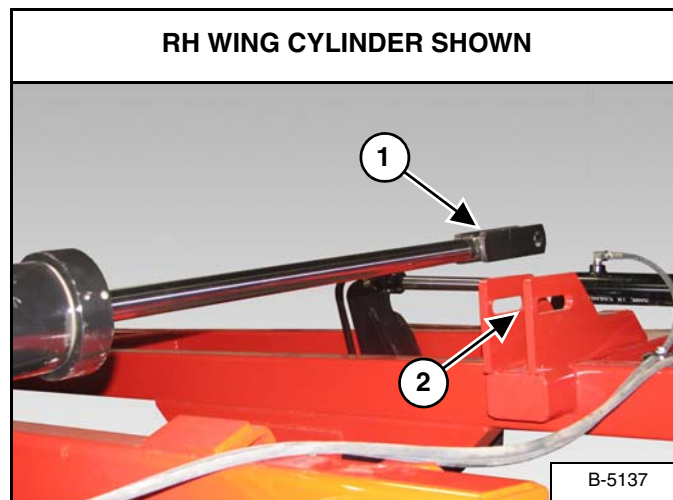

Fully extend the RH & LH wing cylinders.

Turn tractor engine off and exit the tractor.

Align the clevis (Item 1) with the mounting bracket (Item 2) [Figure 84] on the RH & LH wings.

Figure 85

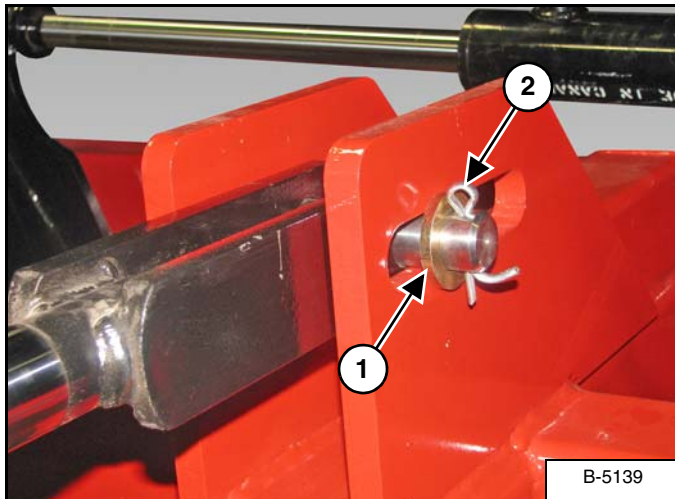

Locate one 1-1/4" x 5-13/16" cylinder pin, three 1-9/32" ID x 2" OD x 1/4" washers, and one 5/16" x 1-3/4" cotter pin.

Install one washer onto the end of the cylinder pin. Push the pin through the first bracket of the cylinder mount and the cylinder clevis.

Slide another washer between the cylinder clevis and the second bracket of the cylinder mount.

Push the cylinder pin through the washer and second bracket of the cylinder mount.

Install another washer (Item 1) **[Figure 85]** on the end of the cylinder pin and secure with a cotter pin (Item 2) **[Figure 85]**. Then install the cylinder pin through the mounting bracket and clevis.

Repeat for LH wing cylinder.

Enter the tractor and start the engine.

Using the tractor's auxiliary controls, cycle the hydraulic cylinders on the tandem disc to test for correct operation.

Fully raise the tandem disc frame and fully unfold RH & LH wings.

Turn tractor engine off and exit the tractor.

Close shut-off valves.

PURGING / REPHASING HYDRAULIC SYSTEM

IMPORTANT

Failure to purge hydraulic system of air or rephase depth control cylinders, could result in uneven working depth across the width of the machine, as one or more cylinders may creep, “bounce” or move erratically.

Purging Hydraulic System

Following assembly and prior to placing the tandem disc into field service, it is important the series depth control cylinders be purged of air that has been trapped in the system.

Use the following procedure to purge trapped air from the hydraulic system:

1. Connect the tandem disc hydraulics to tractor and remove all depth control stops.
2. Raise tandem disc to extend lift cylinders fully and hold hydraulic lever in the UP position for (3) three minutes.
3. Lower tandem disc to retract lift cylinders fully.

NOTE: All lift cylinders may not fully retract.

4. Raise tandem disc again and hold hydraulic lever in the UP position for another (3) three minutes.

Rephasing Hydraulic System

Following the initial purging of the series hydraulic system, it is a recommended practice to rephase the depth cylinders several times each day by holding hydraulic lever in the UP position for (5-10) five to ten seconds. This can be normally done when disc is raised to make a turn at the end of the field.

IMPORTANT

Hydraulic pressure in the tandem disc system must be relieved at the end of the day and prior to uncoupling from tractor. Always lower tandem disc with the tractor running, failure to do so will result in air getting back into the rephasing system.

GANG SECTIONS

Gang Beam Extension Chart

10.5 INCH SPACING						
WIDTH	FRAME TYPE	# OF BLADES		# OF BEARINGS	LH / RH FRONT WING BEAMS LENGTH	LH / RH REAR WING BEAMS LENGTH
		FRONT	REAR			
25 Ft.	Super Narrow	28	30	20	70 In.	90 In.
26.5 Ft.	Super Narrow	30	32	20	78 In.	100 In.
29 Ft.	Narrow	32	34	22	91 In.	113 In.
32 Ft.	Narrow	36	38	24	113 In.	135 In.
35.5 Ft.	Wide	40	42	28	134 In.	156 In.
38.5	Wide	44	46	32	156 In.	178 In.

12 INCH SPACING						
WIDTH	FRAME TYPE	# OF BLADES		# OF BEARINGS	LH / RH FRONT WING BEAMS LENGTH	LH / RH REAR WING BEAMS LENGTH
		FRONT	REAR			
24 Ft.	Super Narrow	24	26	20	68 In.	85 In.
26 Ft.	Super Narrow	26	28	20	72 In.	97 In.
28.5 Ft.	Narrow	28	30	22	85 In.	110 In.
30.5 Ft.	Narrow	30	32	24	98 In.	123 In.
32.5 Ft.	Narrow	32	34	24	110 In.	135 In.
36.5 Ft.	Wide	36	38	26	135 In.	160 In.
38.5 Ft.	Wide	38	40	28	148 In.	173 In.

General Information



- DO NOT permit bystanders to be in the work area when unloading and assembling the tandem disc components.
- DO NOT work under suspended parts.
- Keep away from moving parts.
- Always use lifting devices / vehicles, chains or straps of adequate size and strength when unloading and assembling the tandem disc components.



AVOID INJURY OR DEATH

Wear safety glasses to prevent eye injury when any of the following conditions exist:

- When fluids are under pressure.
- Flying debris or loose material is present.
- Engine is running.
- Tools are being used.



AVOID INJURY OR DEATH

Keep fingers and hands out of pinch points when assembling the equipment.



Always wear protective gloves when installing, removing or servicing gang sections to help prevent injury from cutting edges of blades.

Identify the front / rear and left / right gang sections.

For additional gang section information. (See “GANG SECTIONS” on page 64.)

Figure 86

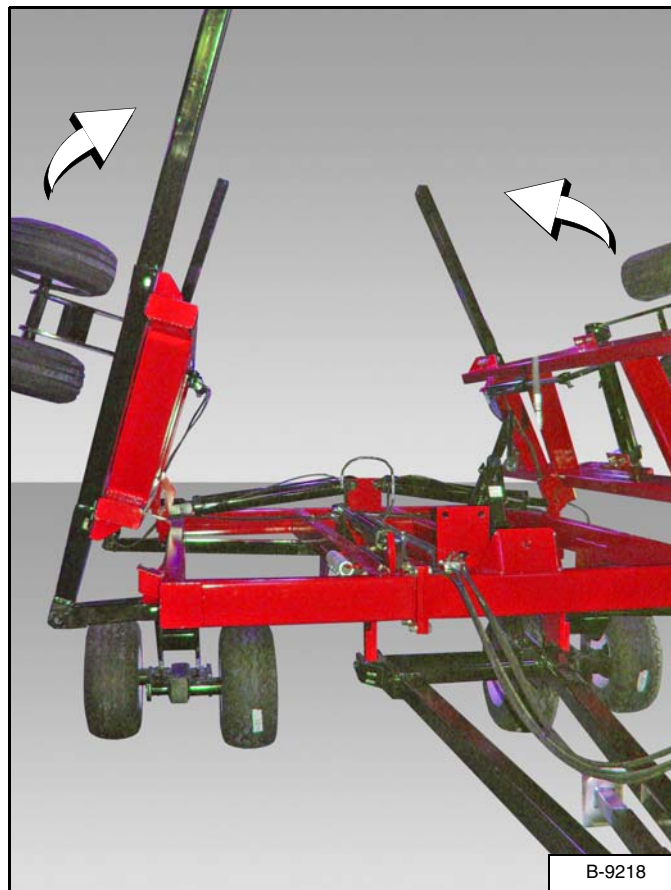

Connect the hydraulic hoses to the tractor and fully raise the wings [Figure 86].

Turn tractor engine off and close valves on tandem disc.

Installing The Gang Sections

Installing The Inside Gang Sections

NOTE: The following procedure shows installing the left front gang sections. The procedure is correct for all gang sections.

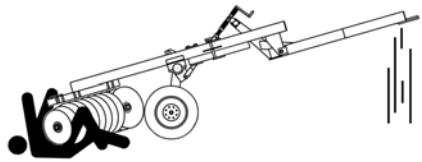

AVOID SERIOUS INJURY OR DEATH

- Always install front gang sections first.
- When installing or removing gang sections, always securely block / support the main frame to avoid tipping.
- DO NOT work under suspended parts.
- Always use lifting devices / supports of adequate size and strength to securely support the tandem disc.

Figure 87

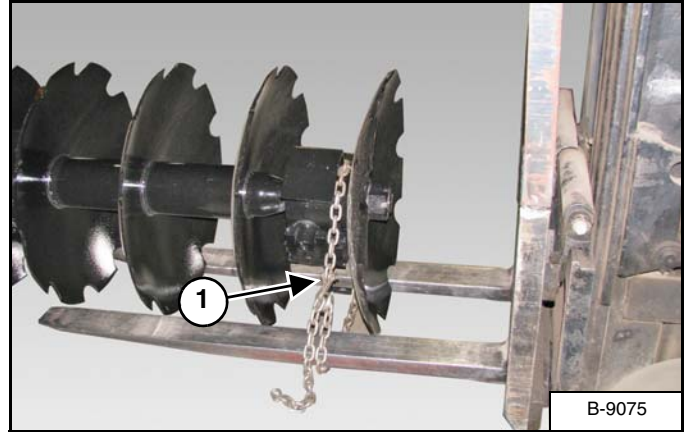

Locate the front left, inside gang section. (Refer to the gang section diagram for the correct corresponding letter and orientation.)

Using a forklift, position forks under gang section and install a chain (Item 1) [Figure 87] around the gang section and forks.

Raise and move the gang section to the assembly area.

NOTE: The background has been removed from some of the following images for picture clarity.

Figure 88

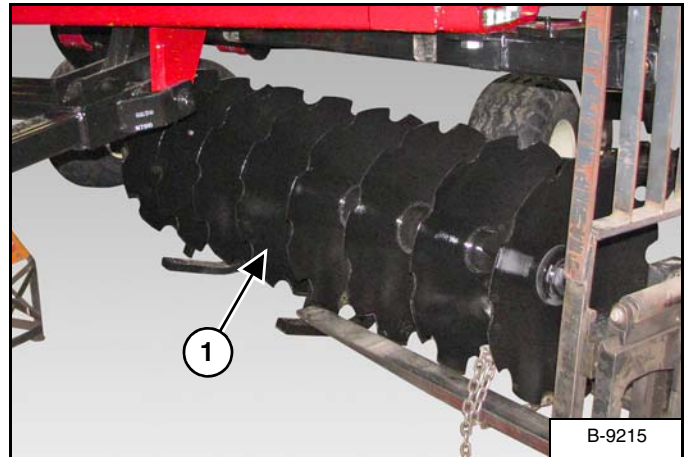

Align and raise the gang section (Item 1) [Figure 88] under the gang beam on the main frame.

NOTE: Do not remove chain until gang section is attached to the gang beam.

Standard Rigid Hangers

See Stone Flex Hangers on page 68 for installing stone flex hangers.

NOTE: The following image may not show your gang section exactly as it appears but the procedure is correct.

! IMPORTANT

Hanger bracket must be sitting square with gang beam before tightening u-bolts.

Figure 89

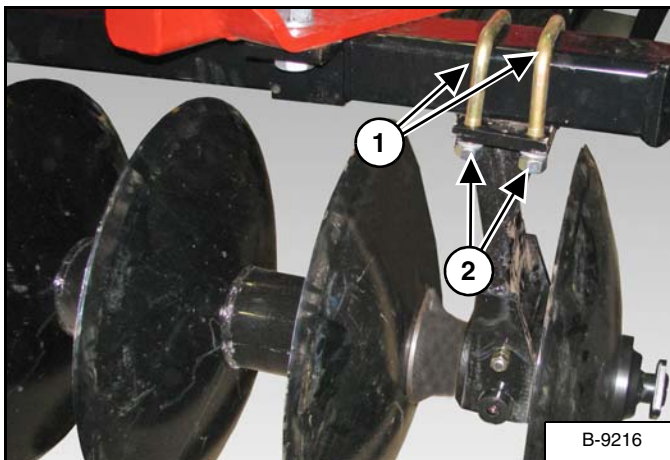

Locate two 7/8" x 5-7/8" u-bolts, four 7/8" lock washers and four 7/8" nuts per bearing hanger (each hanger bracket).

Raise the gang section until the mounting plate contacts the bottom of the gang beam.

Install two 7/8" x 5-7/8" u-bolts (Item 1) [Figure 89] over the gang beam and down through the mounting plate holes.

Install 7/8" lock washers and 7/8" nuts (Item 2) [Figure 89] onto the u-bolts. Do not tighten at this time.

Repeat for remaining rigid hanger bearings on the gang section.

Stone Flex Hangers

NOTE: The following images may not show your gang section exactly as it appears but the procedure is correct.

! IMPORTANT

Hanger bracket must be sitting square with gang beam before tightening u-bolts.

! IMPORTANT



STONE FLEX HANGERS

If the disc is equipped with stone flex hangers:
Always install the gang sections with open end of the spring shank facing the rear of the tandem disc.

Figure 90

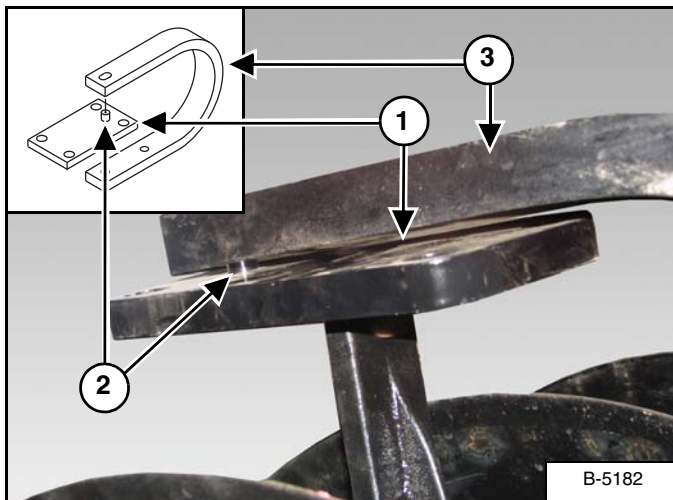

Locate one backing plate (Item 1) [Figure 90] per bearing hanger (each gang section).

Insert the peg (Item 2) into the slot at the end of the spring shank (Item 3) [Figure 90].

Rotate the backing plate 180° under the spring shank.

Rotate spring shank and backing plate up, under the gang beam.

! IMPORTANT

All bearing hangers must be positioned square under gang beam.

Figure 91

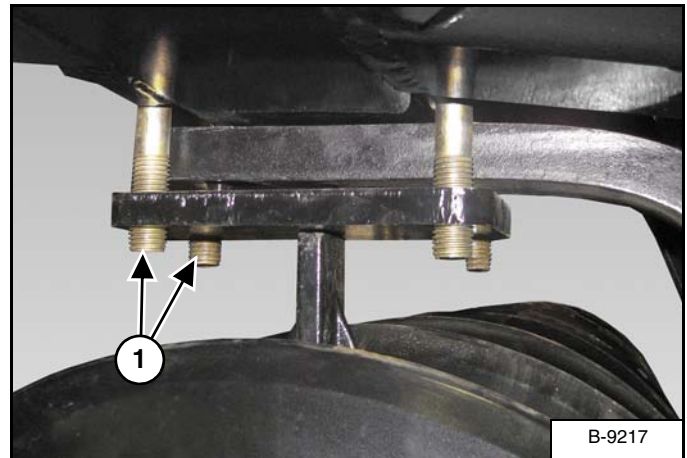

Locate two 7/8" x 7-1/8" u-bolts, four 7/8" lock washers and four 7/8" nuts per bearing hanger (each gang section).

Raise the gang section until the spring shank contacts the bottom of the gang beam.

Install two 7/8" x 7-1/8" u-bolts (Item 1) [Figure 91] over the gang beam and down through the backing plate holes.

Figure 92

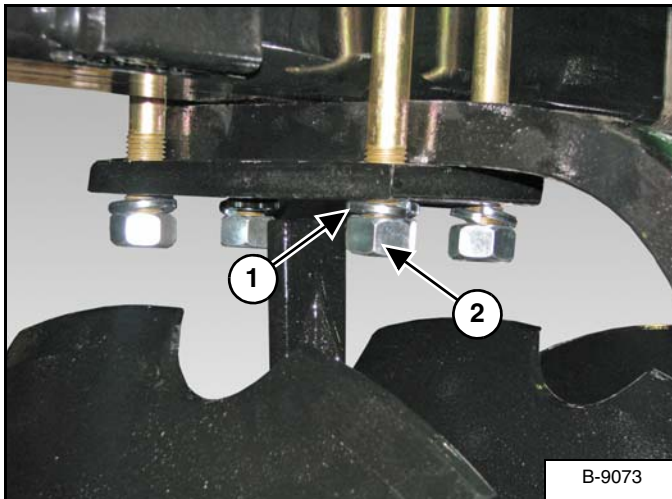

Install 7/8" lock washers (Item 1) and 7/8" nuts (Item 2) [Figure 92] onto the u-bolts. Do not tighten at this time.

Repeat [Figure 90] - [Figure 92] for remaining hanger bearings on the gang section.

Positioning Front Left Inside Gang Section

Figure 93

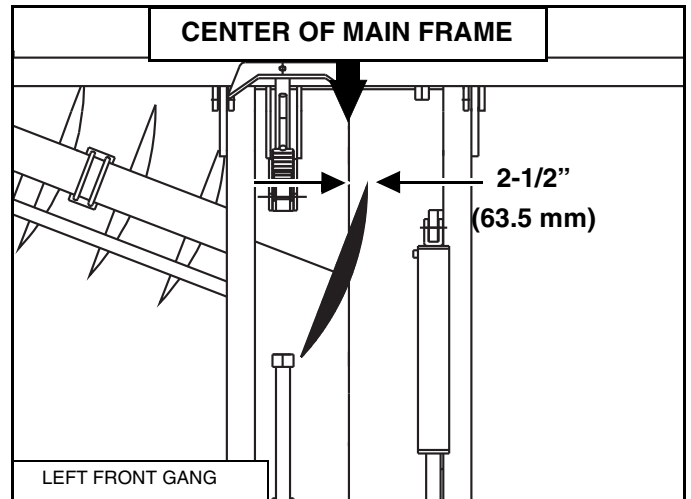

Locate and mark the center of the main frame.

Position the front inside gang section, so that the leading edge of inside blade is approximately 2-1/2" (63.5 mm) past center of main frame [Figure 93].

! IMPORTANT

Always tighten inside hanger bearing u-bolts first, while maintaining the 2-1/2" (63.5 mm) spacing past center of main frame. Tighten all bearing hanger u-bolts to 430 ft.-lb. (583 N•m) torque.

! IMPORTANT

Verify that all bearing hangers are positioned square under gang beam before tightening the u-bolts.

Tighten inside hanger bearing u-bolts, then tighten remaining hanger bearing u-bolts on the inside gang section.

Positioning Front Right Inside Gang Section

Figure 94

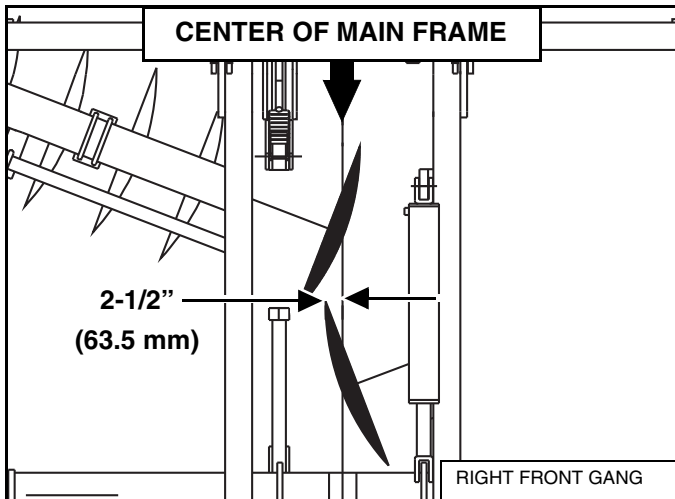

Position the front right inside gang section, so that the leading edge of inside blade is approximately 2-1/2" (63.5 mm) past center of main frame [Figure 94].

! IMPORTANT

Always tighten inside hanger bearing u-bolts first, while maintaining the 2-1/2" (63.5 mm) spacing past center of main frame. Tighten all bearing hanger u-bolts to 430 ft.-lb. (583 N•m) torque.

! IMPORTANT

Verify that all bearing hangers are positioned square under gang beam before tightening the u-bolts.

Tighten inside hanger bearing u-bolts, then tighten remaining hanger bearing u-bolts on the inside gang section.

Positioning Inside Rear Gang Sections

Figure 95

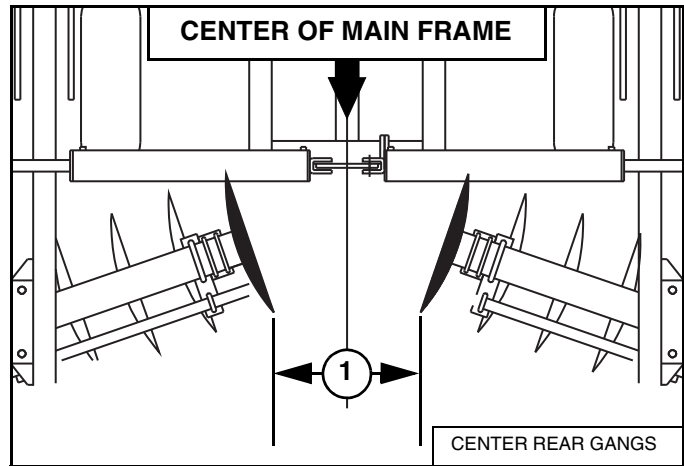

Center rear inside gang sections, so that the distance between the rear edge of the two inside blades (Item 1) [Figure 95], is equal to 2" (50.8 mm) less than diameter of blades with a maximum of 24" (610 mm).

EXAMPLE - if the disc is equipped with 24" (610 mm) diameter blades, (Item 1) [Figure 95] would be set at 22" (559 mm).

NOTE: If the disc is equipped with 26" (660 mm) or 28" (711 mm) diameter blades, (Item 1) [Figure 95] would be set at a maximum of 24" (610 mm).

! IMPORTANT

Always tighten inside hanger bearing u-bolts first, while maintaining the desired spacing between the rear edge of the two inside blades. Tighten all bearing hanger u-bolts to 430 ft.-lb. (583 N•m) torque.

! IMPORTANT

Verify that all bearing hangers are positioned square under gang beam before tightening the u-bolts.

Tighten inside hanger bearing u-bolts, then tighten remaining hanger bearing u-bolts on the rear gang sections.

Outside Gang Section Installation

NOTE: The following procedure shows installing the left front outside gang section. The procedure is the same for all outside gang sections.

Figure 96

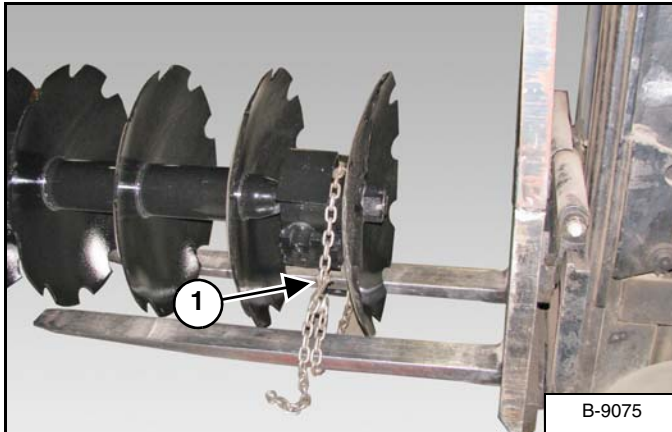

Locate the front left, outside gang section. (Refer to the gang section diagram for the correct corresponding letter and orientation.)

Using a forklift, position forks under gang section and install a chain (Item 1) [Figure 96] around the gang section and forks.

Raise and move the gang section to the assembly area.

NOTE: The background has been removed from some of the following images for picture clarity.

Figure 97



Position the front left, outside gang section. (Refer to the gang section diagram for the correct corresponding letter and orientation.)

Lower the gang section onto the ground in line with the left wing frame gang beam.

NOTE: When adjusting / aligning gang sections, always maintain the designated blade spacing between gang sections.

Raise the gang section and move inner blade towards the inside gang section (approximate blade spacing distance). Lower gang section to the ground.

Repeat for the three remaining outside gang sections.

Standard Rigid Hangers

See Stone Flex Hangers on page 68 for installing stone flex hangers.

NOTE: The following image may not show your gang section exactly as it appears but the procedure is correct.

! IMPORTANT

Hanger bracket must be sitting square with gang beam before tightening u-bolts.

Figure 98

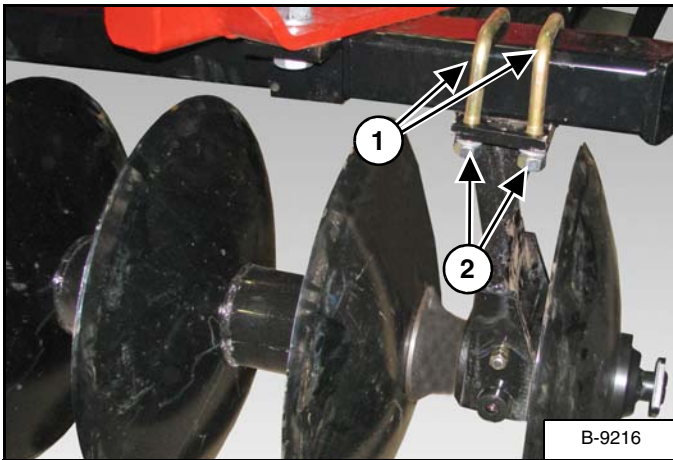

Locate two 7/8" x 5-7/8" u-bolts, four 7/8" lock washers and four 7/8" nuts per bearing hanger (each hanger bracket).

Raise the gang section until the mounting plate contacts the bottom of the gang beam.

Install two 7/8" x 5-7/8" u-bolts (Item 1) [Figure 98] over the gang beam and down through the mounting plate holes.

Install 7/8" lock washers and 7/8" nuts (Item 2) [Figure 98] onto the u-bolts. Do not tighten at this time.

Repeat for remaining rigid hanger bearings on the gang section.

Stone Flex Hangers

NOTE: The following images may not show your gang section exactly as it appears but the procedure is correct.

! IMPORTANT

Hanger bracket must be sitting square with gang beam before tightening u-bolts.

! IMPORTANT



STONE FLEX HANGERS

If the disc is equipped with stone flex hangers:

Always install the gang sections with open end of the spring shank facing the rear of the tandem disc.

Figure 99

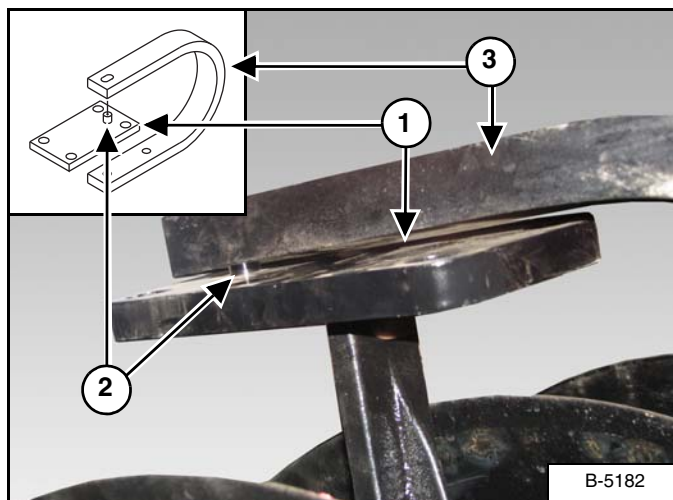

Locate one backing plate (Item 1) [Figure 99] per bearing hanger (each gang section).

Insert the peg (Item 2) into the slot at the end of the spring shank (Item 3) [Figure 99].

Rotate the backing plate 180° under the spring shank.

Rotate spring shank and backing plate up, under the gang beam.

! IMPORTANT

All bearing hangers must be positioned square under gang beam.

Figure 100

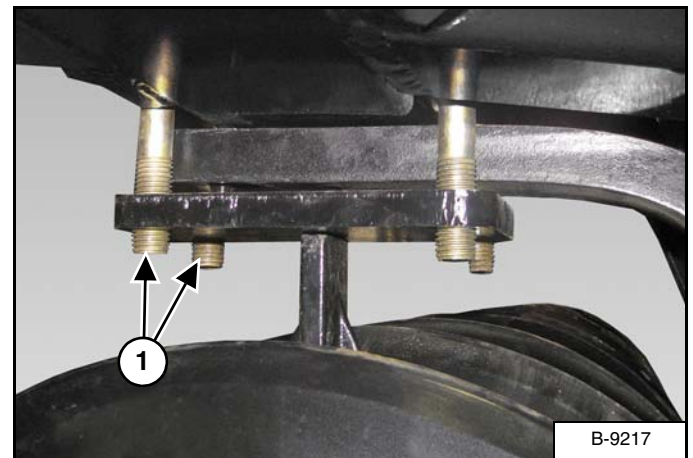

Locate two 7/8" x 7-1/8" u-bolts, four 7/8" lock washers and four 7/8" nuts per bearing hanger (each gang section).

Raise the gang section until the spring shank contacts the bottom of the gang beam.

Install two 7/8" x 7-1/8" u-bolts (Item 1) [Figure 100] over the gang beam and down through the backing plate holes.

Figure 101

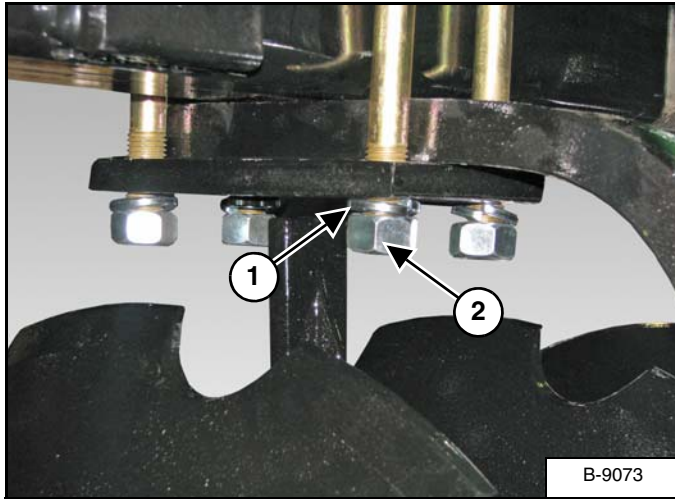

Install 7/8" lock washers (Item 1) and 7/8" nuts (Item 2) [Figure 101] onto the u-bolts. Do not tighten at this time.

Repeat [Figure 99] - [Figure 101] for remaining hanger bearings on the gang section.

Figure 102

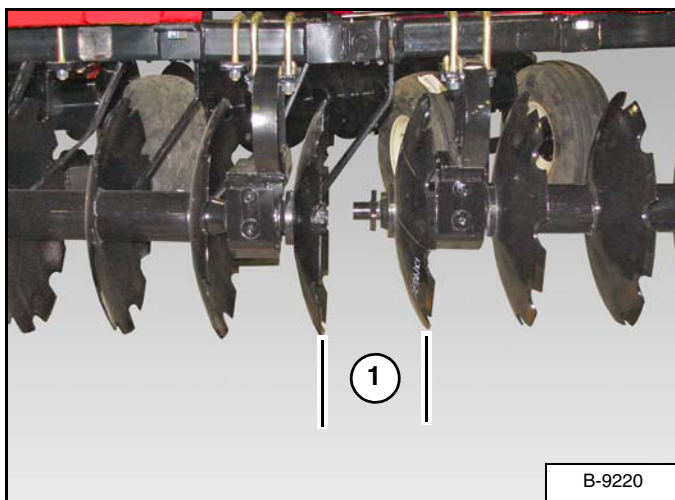

Adjust outside gang section (in or out) until the spacing (Item 1) [Figure 102] between inside and outside gangs is at the designated blade spacing.

! IMPORTANT

Always tighten inside hanger bearing u-bolts first, while maintaining designated blade spacing. Tighten all bearing hanger u-bolts to 430 ft.-lb. (583 N•m) torque.

Verify that all bearing hangers are positioned square under gang beam before tightening the u-bolts.

Tighten inside hanger bearing u-bolts, then tighten remaining hanger bearing u-bolts on the front inside gang section.

! IMPORTANT

BEARING

Loosen all the bolts, which fasten the bearings to the hangers. Then turn the disc blades to allow the bearings to align themselves. Re-tighten all the bolts. This will ensure proper bearing alignment.

Install remaining gang sections. (See "Installing The Gang Sections" on page 66.)

Installing The Scraper Bar And Scrapers

Standard Scraper Bar Mounting

Figure 103

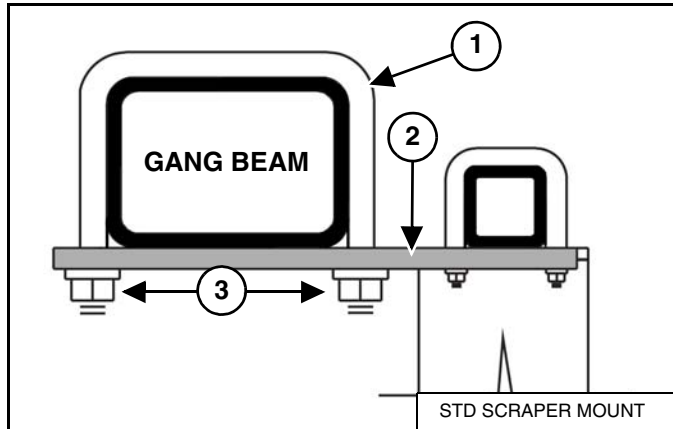

Install one 3/4" x 6-7/8" u-bolt (Item 1) over the gang beam and down through the scraper bar mount (Item 2). Install two 3/4" lock washers and two 3/4" nuts (Item 3) [Figure 103] on the u-bolt. Do not tighten at this time.

Continue installing the remaining scraper bar mounts as required.

NOTE: Mount (Item 2) [Figure 103] is positioned so scraper bar is located at rear of gangs.

NOTE: Each disc model is supplied with one scraper mount bracket per hanger.

Offset scraper mount brackets are provided for tight locations where the standard scraper bracket won't fit. There are four offset brackets supplied per machine. If required, use offset brackets as standard scraper brackets.

In general, locate the outside bracket for each scraper bar as close to the end as possible. Try to avoid having the outer brackets located behind two scrapers. Locate the inner brackets next to bearing hangers.

Offset Scraper Bar Mounting

Figure 104

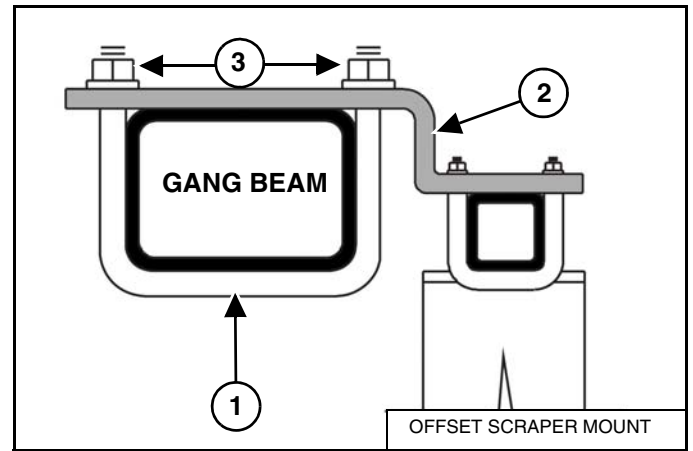

Install one 3/4" x 6-7/8" u-bolt (Item 1) over the gang beam and up through the scraper bar mount (Item 2). Install two 3/4" lock washers and two 3/4" nuts (Item 3) [Figure 104] on the u-bolt. Do not tighten at this time.

Continue installing the remaining scraper bar mounts as required.

NOTE: Mount (Item 2) [Figure 104] is positioned so scraper bar is located at rear of gangs.

Locate each gang section, corresponding scraper assemblies and hardware that were removed before installing gang sections.

! **IMPORTANT**

Each gang section and corresponding scraper assembly must be installed together.

Installing The Scraper Bars

Figure 105

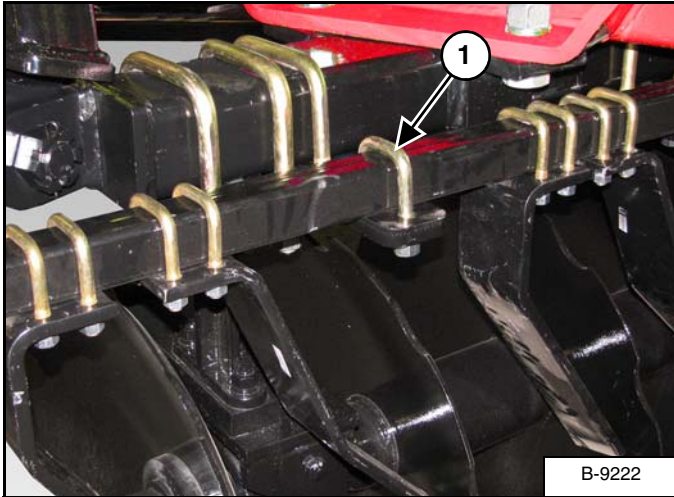

Install 5/8" x 2" u-bolts (Item 1) [Figure 105] down, over the scraper bar and into the mounts.

! IMPORTANT

Scrapers are pre-installed on the scraper bars at the factory.

Figure 106

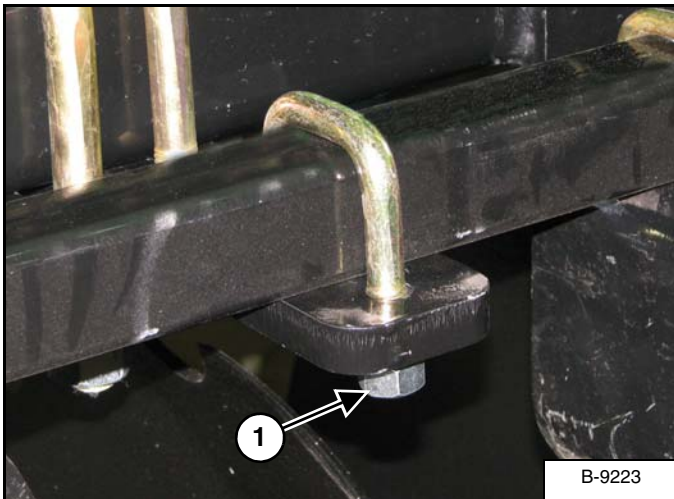

Install 5/8" lock washers and 5/8" nuts (Item 1) [Figure 106] onto each u-bolt. Do not tighten at this time.

Continue installing the remaining corresponding scraper bars.

Standard Scrapers

NOTE: See pages 82 - 88 for 90 degree scraper location per Tandem Disc model.

Figure 107

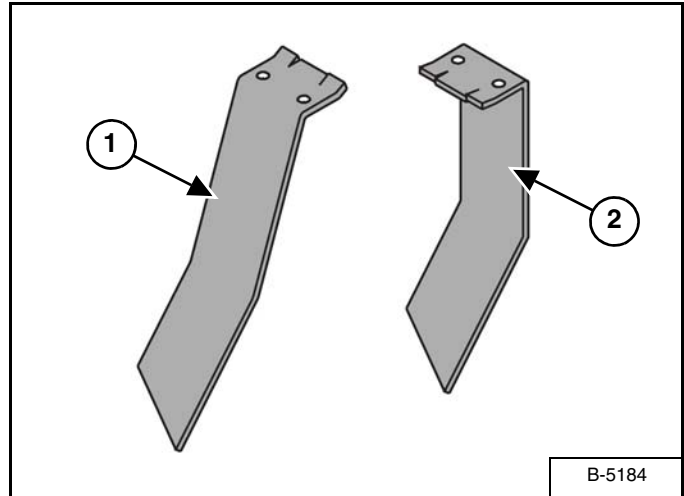

Front LH / rear RH standard scraper (Item 1) and front LH / rear RH standard 90° scraper (Item 2) [Figure 107].

NOTE: Front RH and rear LH scrapers are opposite of the scrapers shown in [Figure 107].

Wide Pan Scrapers

Figure 108

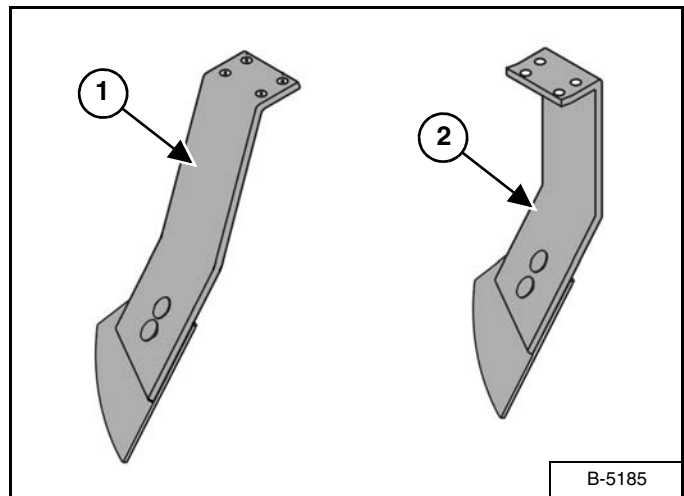

Front LH / rear RH wide pan scraper (Item 1) and front LH / rear RH wide pan 90° scraper (Item 2) [Figure 108].

NOTE: Front RH and rear LH scrapers are opposite of the scrapers shown in [Figure 108].

Installing Hydraulic Hose Bracket

Figure 109

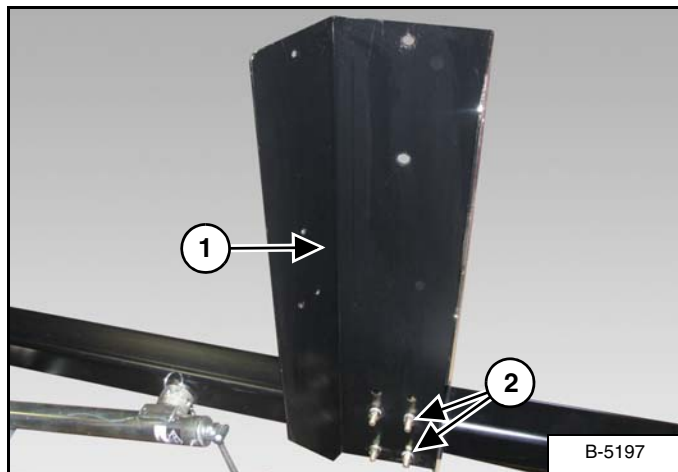

Locate the hydraulic hose bracket (Item 1) [Figure 109], two 1/2" x 4-9/16" u-bolts, four 1/2" lock washers and four 1/2" nuts.

Align the hydraulic hose bracket on the same side as the hitch jack. Position the bracket on tube approximately 16" from the end of the tube.

Install the two 1/2" x 4-9/16" u-bolts around the hitch and through the hydraulic hose bracket (Item 1). Install the four 1/2" lock washers and 1/2" nuts (Item 2) [Figure 109] on the u-bolts. Tighten nuts to secure the hydraulic hose bracket to the hitch.

Installing Manual Storage Container

Figure 110

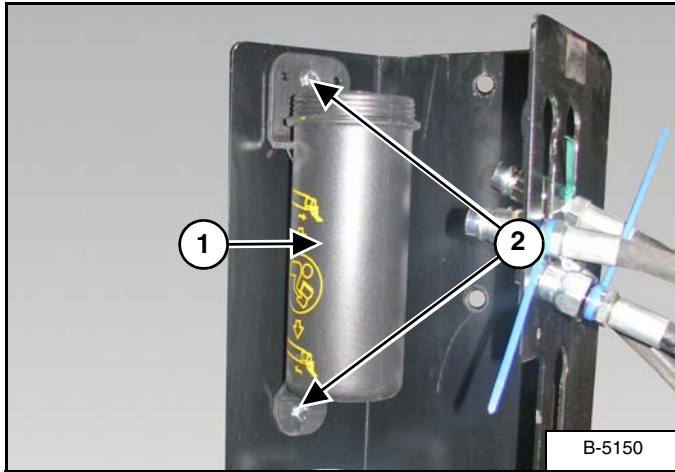

Locate the manual storage container (Item 1) [Figure 110], two 5/16" x 3/4" bolts, two 5/16" lock washers and two 5/16" nuts.

Align the manual storage container with the mounting bracket on the hitch.

Install the two 5/16" x 3/4" bolts (Item 2) through the manual storage container (Item 1) [Figure 110] and mounting bracket. Install one 5/16" lock washer and 5/16" nut on each bolt. Tighten bolts and nut to secure the manual storage container to the mounting bracket.

Install manual storage container cap.

LIGHT KIT

Installation

Figure 111

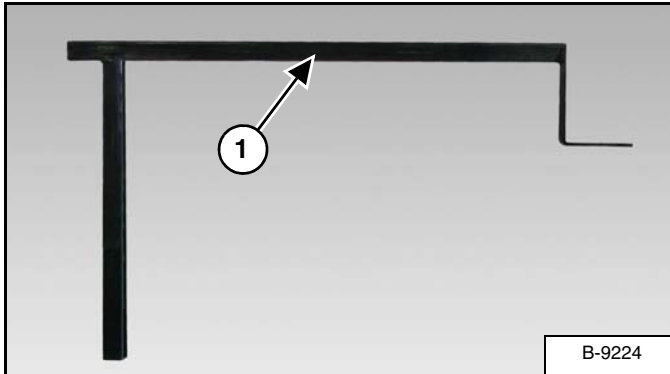

Locate one light bracket (Item 1) [Figure 111].
Move the light bracket to the assembly area.

Figure 112

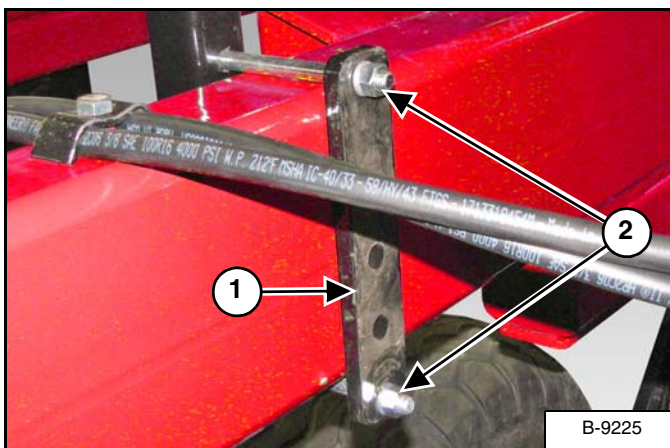

Locate one backing plate (Item 1) [Figure 112], two 1/2" x 8-1/2" bolts, two 1/2" lock washers and two 1/2" nuts.

Position the light bracket towards the rear on the outside frame of the RH center frame. Lower the light bracket inside the frame, align the backing plate and install the two 1/2" bolts (Item 2) [Figure 112], through the backing plate and light bracket. Install 1/2" lock washers and nuts on the bolts. Visually inspect that the light bracket is square (plumb) with the main frame.

NOTE: Verify that the light bracket is positioned in a location where the RH wing will not damage the light bracket when folded.

Tighten the 1/2" bolts and nuts to secure the light bracket to the main frame.

Repeat for installing opposite light bracket.

Figure 113

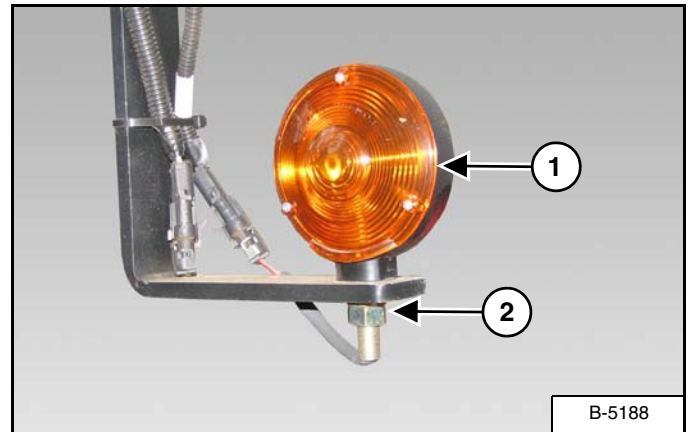

Locate one amber light (Item 1) [Figure 113].

Install the amber light assembly into the lower slot of the light bracket. Position the amber light facing front / rear of the machine.

Tighten nut (Item 2) [Figure 113].

Repeat for opposite amber light assembly.

Figure 114

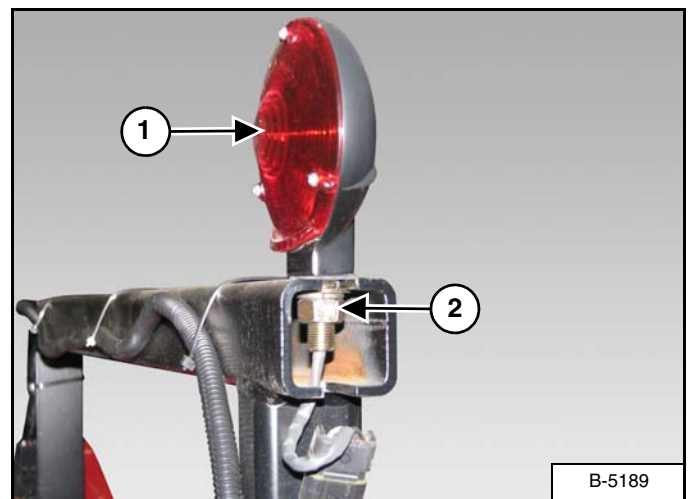

Locate one red light assembly (Item 1) [Figure 114].

Install the red light assembly into the upper slot of the light bracket. Position the red light facing the rear of the machine.

Tighten nut (Item 2) [Figure 114].

Repeat for opposite red light assembly.

Figure 115

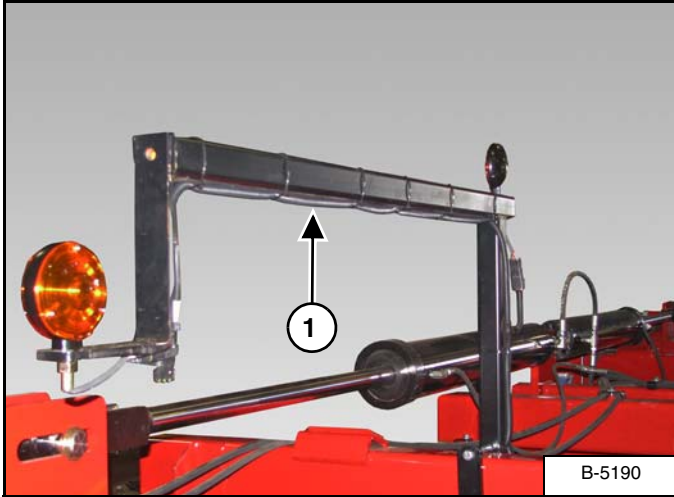

Locate the wire harness (Item 1) [Figure 115].

Connect the wire harness to each of the amber and red lights (both sides).

NOTE: Harness plugs are marked with either LH or RH. Make sure lamp plugs are connected to the correct side.

Route the wire harness down the center of the main frame (along hydraulic hoses) and the front of the hitch.

Using cable ties, secure wire harness to the light brackets and hydraulic hoses.

Figure 116

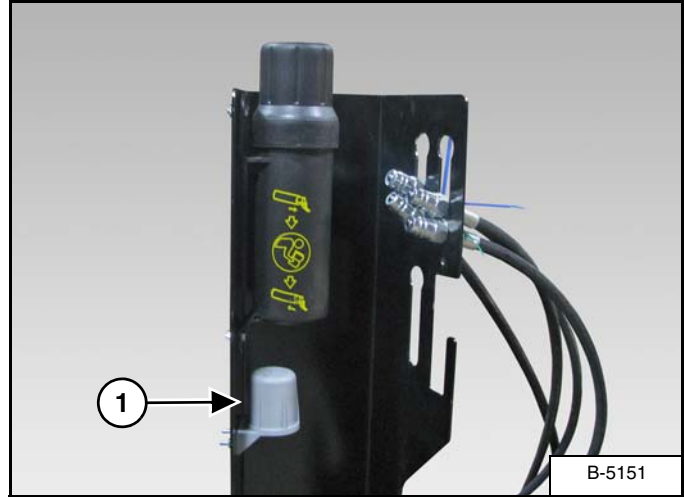

Install storage cup (Item 1) [Figure 116] below manual holder using one 1/4" x 5/8" bolt, 1/4" lockwasher, and 1/4" nut.

Figure 117

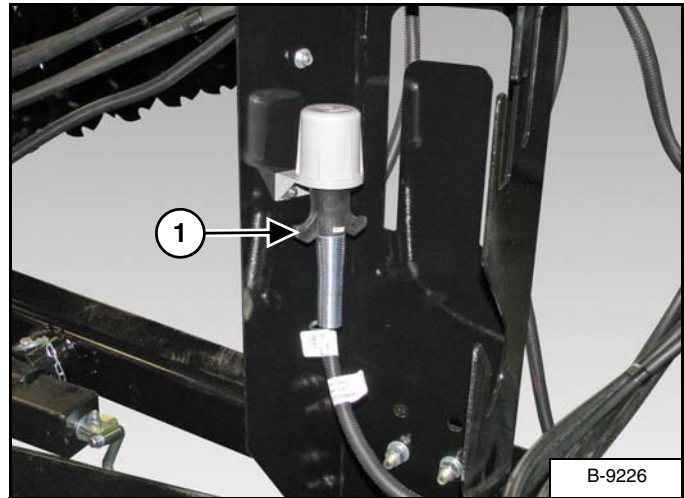

Install the wire harness 7-pin connector in the storage cup (Item 1) [Figure 117] on the hydraulic hose bracket.

DEPTH STOPS

Figure 118



Locate the two sets of depth stops [Figure 118].

Figure 119

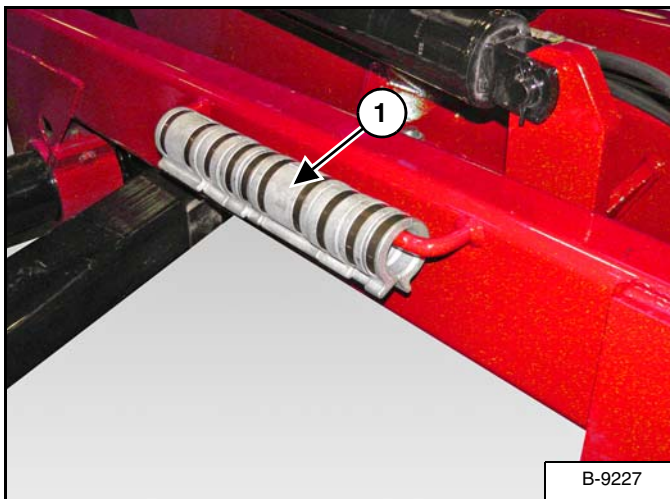

Store unused depth stops on the rod (Item 1) [Figure 119] just behind the front main frame (center).

Figure 120

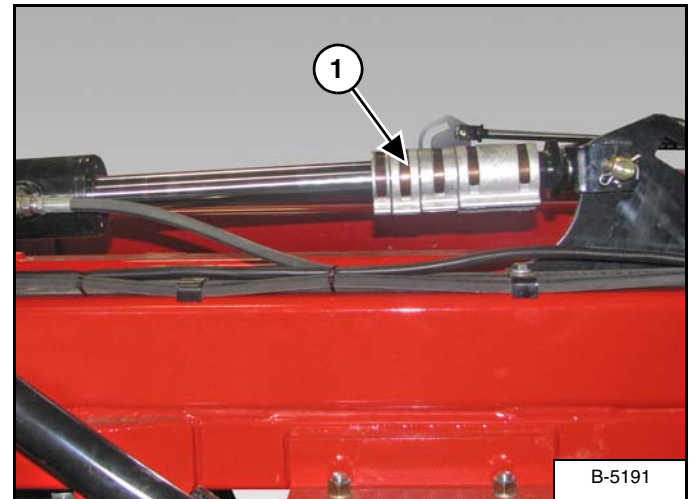

Install depth stops (Item 1) [Figure 120] on the main rockshaft cylinder as needed for transport or to maintain working depth.

! IMPORTANT

ALL depth stops must be installed on main frame rockshaft cylinder when transporting disc.

The depth stops will have a total length of 17 inches

GANG PATTERNS

10-1/2 Inch Spacing - 58 Blades / 20 Bearings

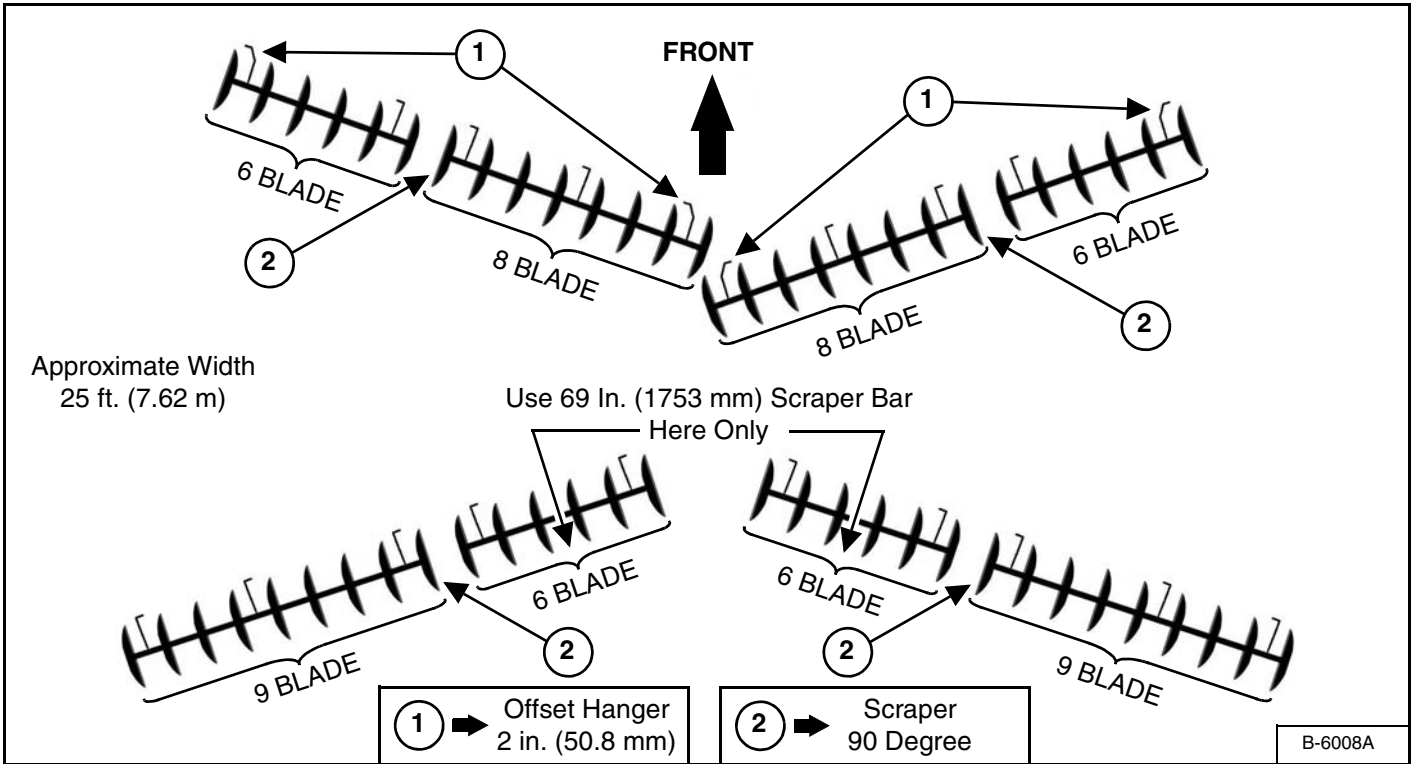

10-1/2 Inch Spacing - 62 Blades / 20 Bearings

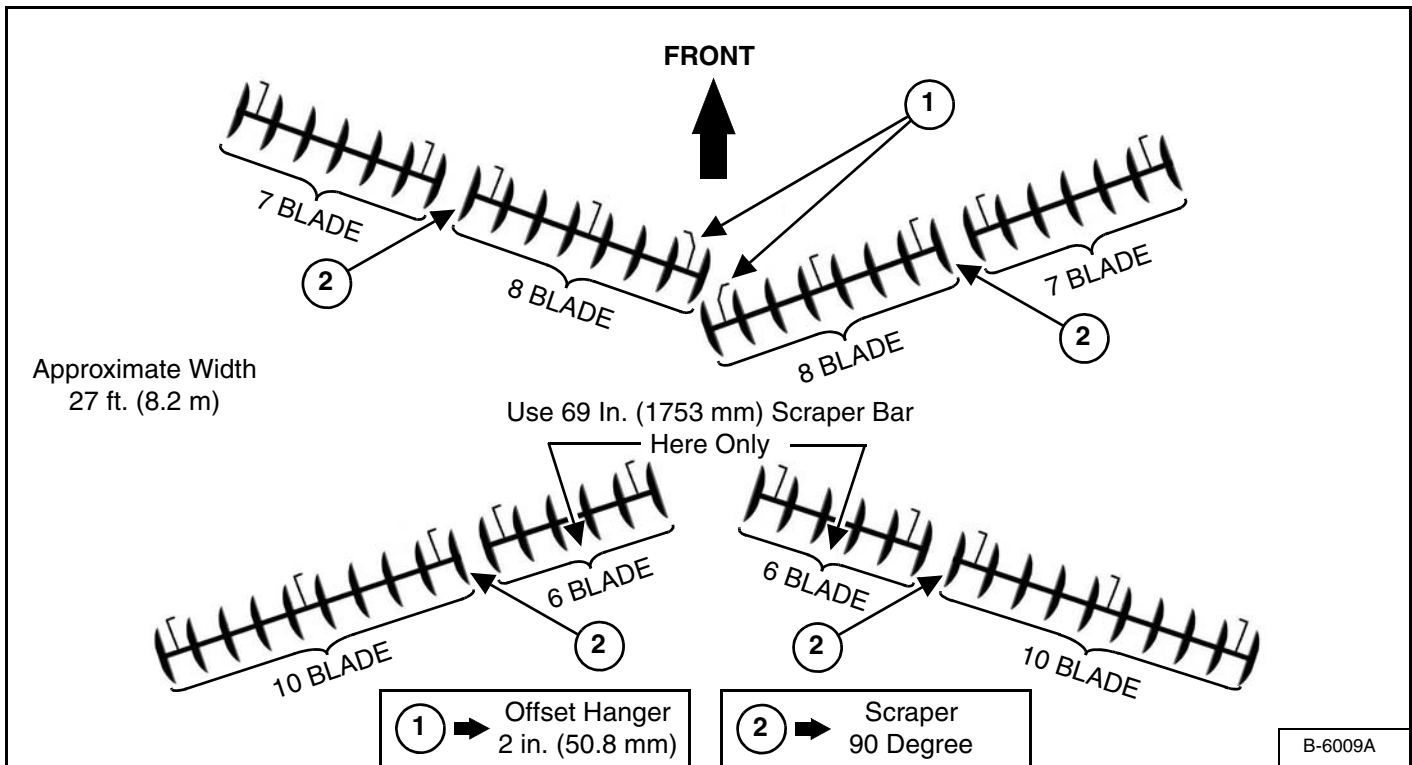

GANG PATTERNS (CONT'D)

10-1/2 Inch Spacing - 66 Blades / 22 Bearings

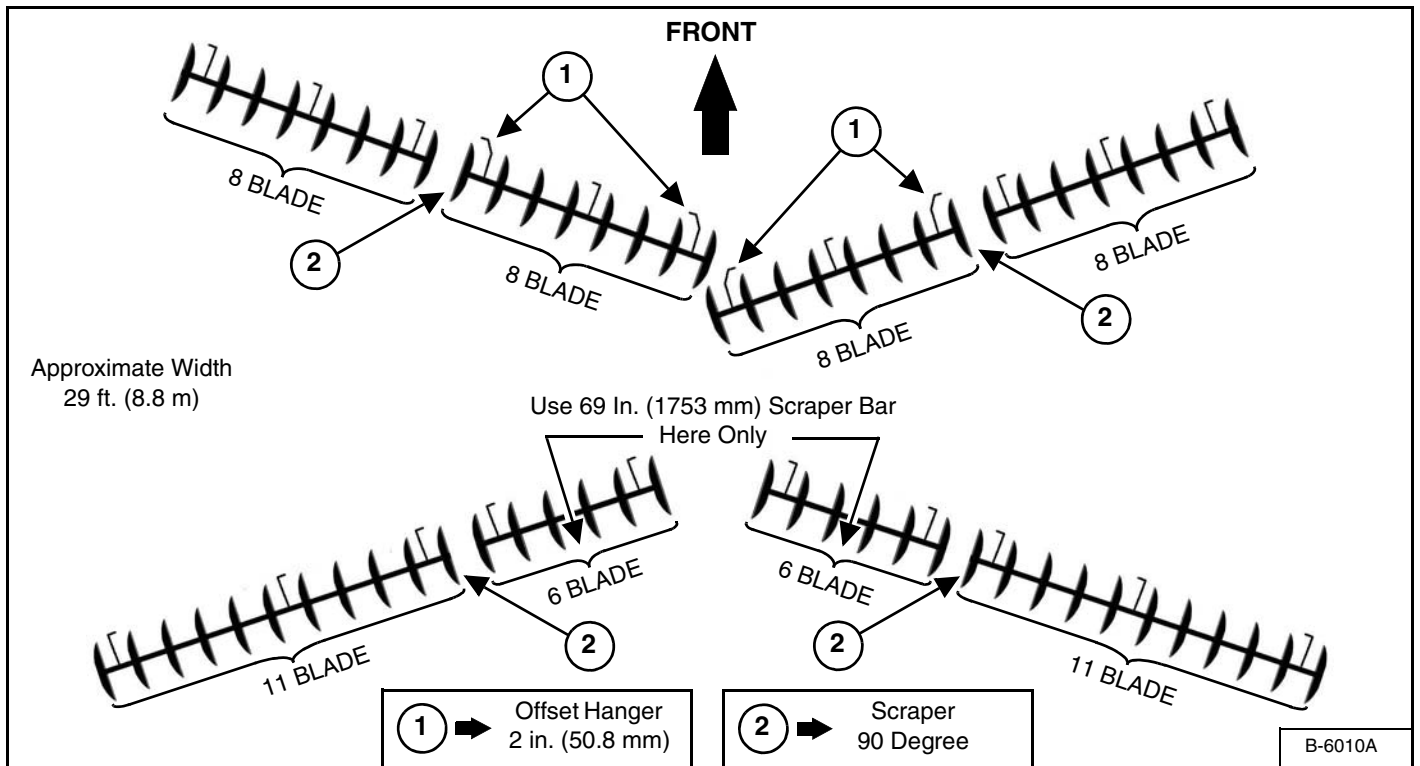

10-1/2 Inch Spacing - 74 Blades / 24 Bearings

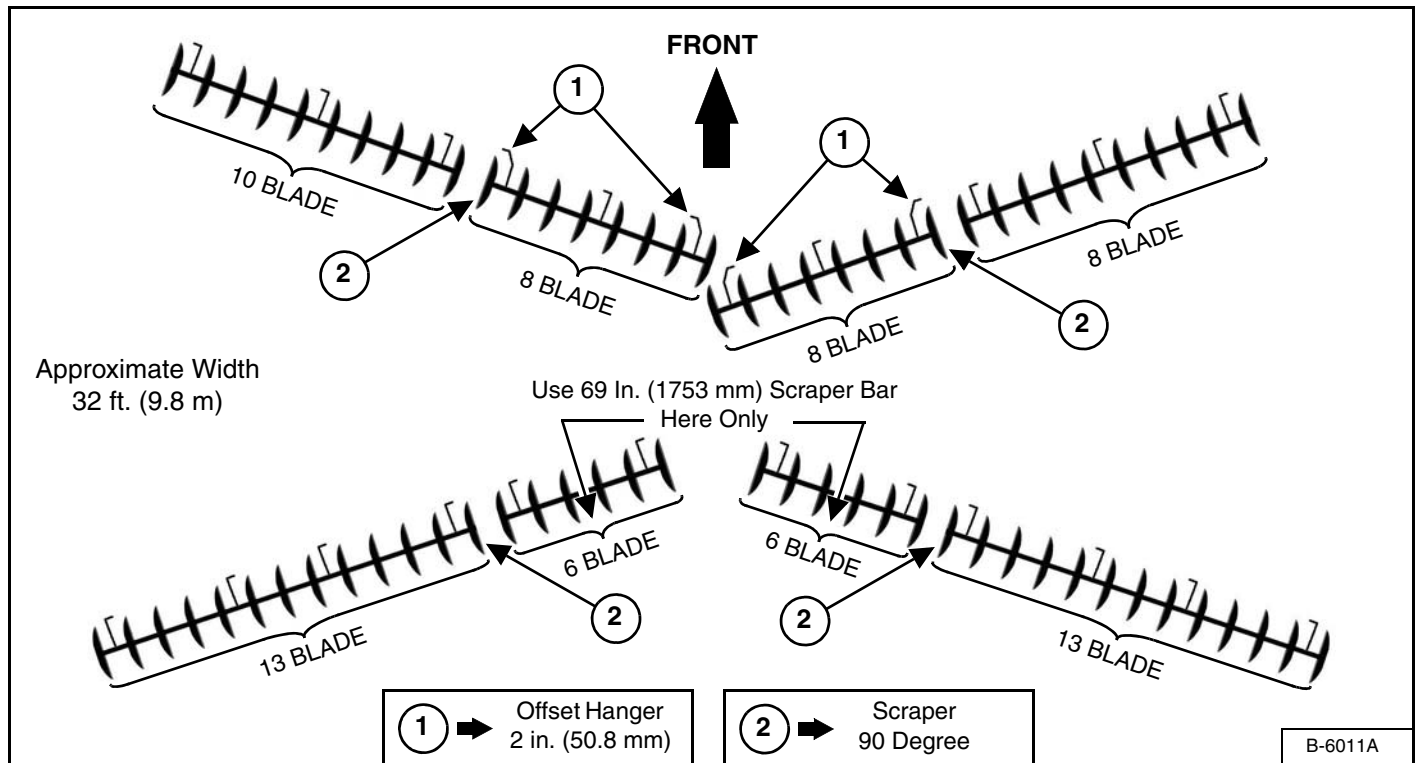

GANG PATTERNS (CONT'D)

10-1/2 Inch Spacing - 82 Blades / 28 Bearings

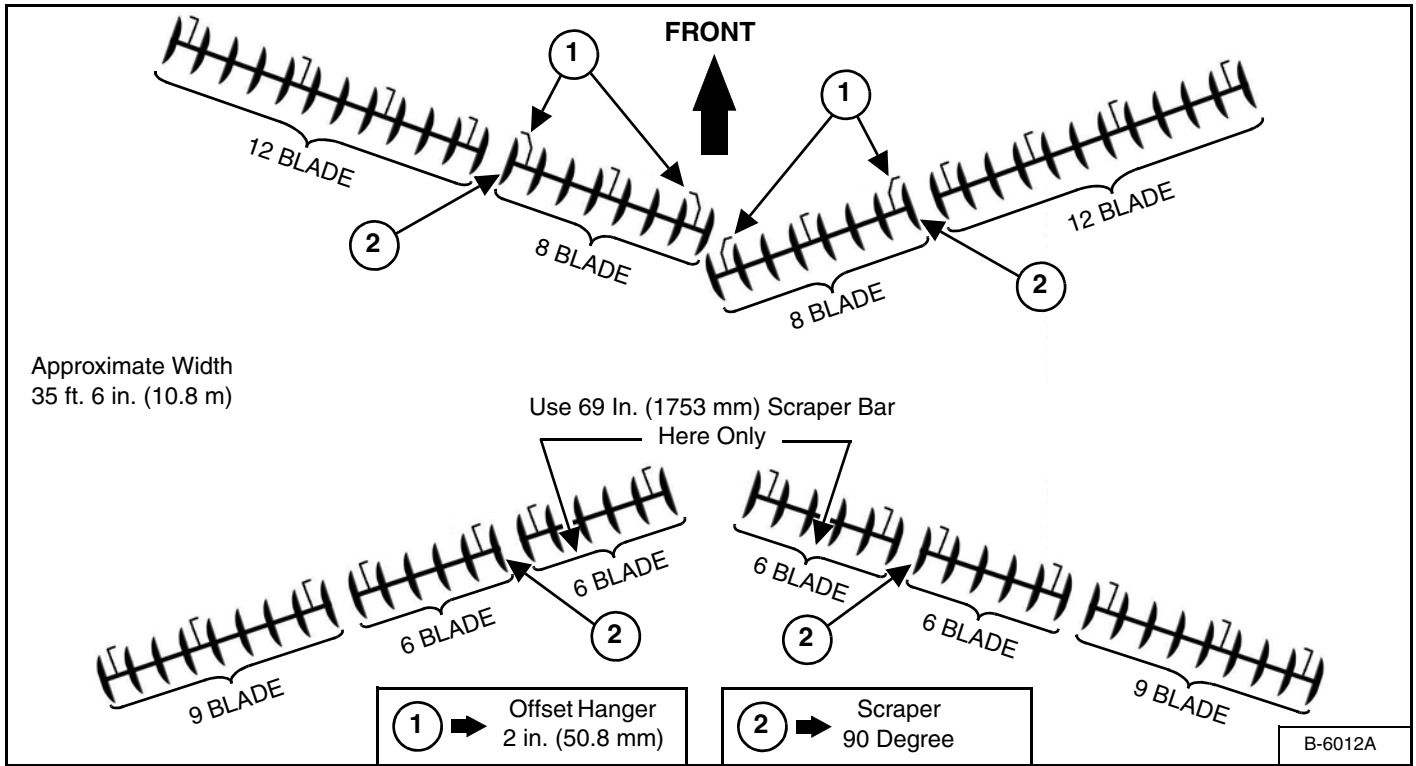

10-1/2 Inch Spacing - 90 Blades / 32 Bearings

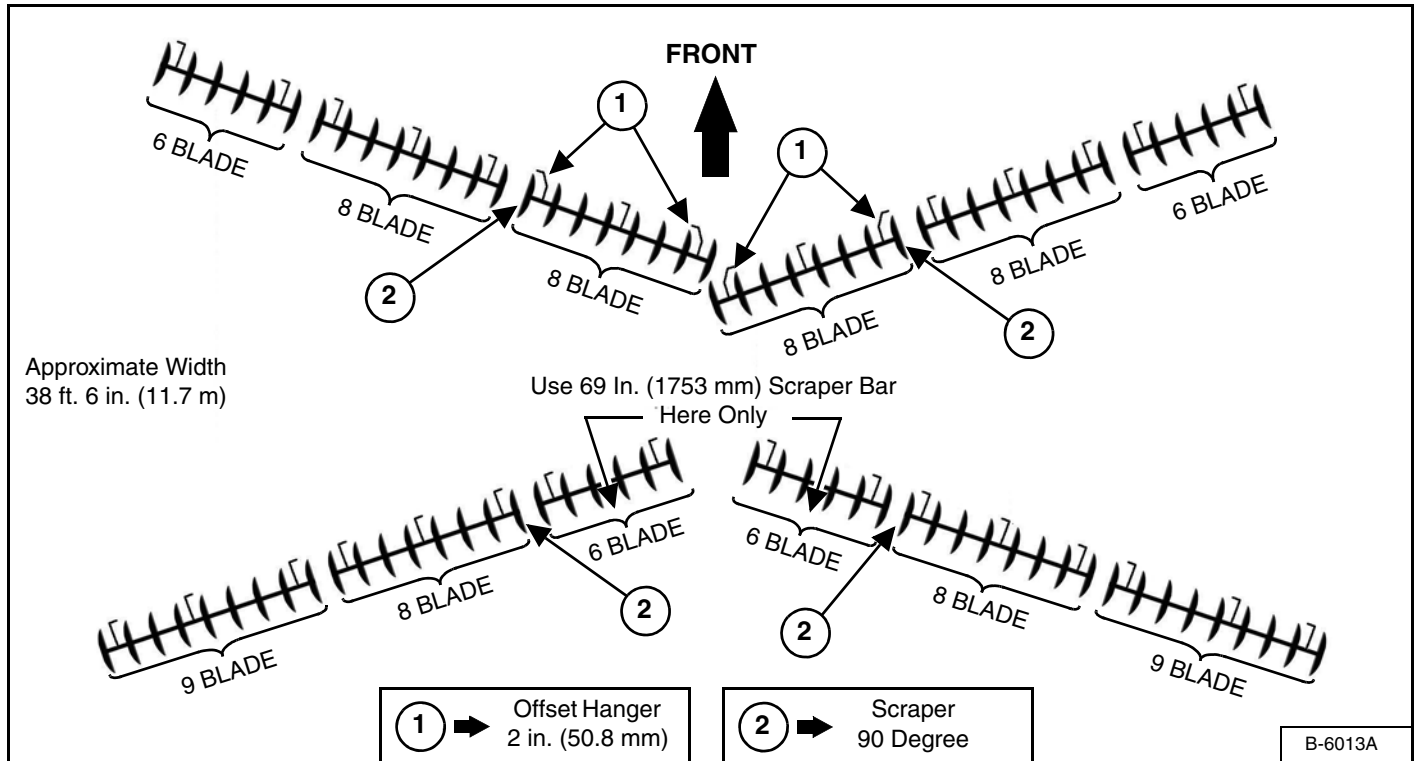

GANG PATTERNS (CONT'D)

12 Inch Spacing - 50 Blades / 20 Bearings

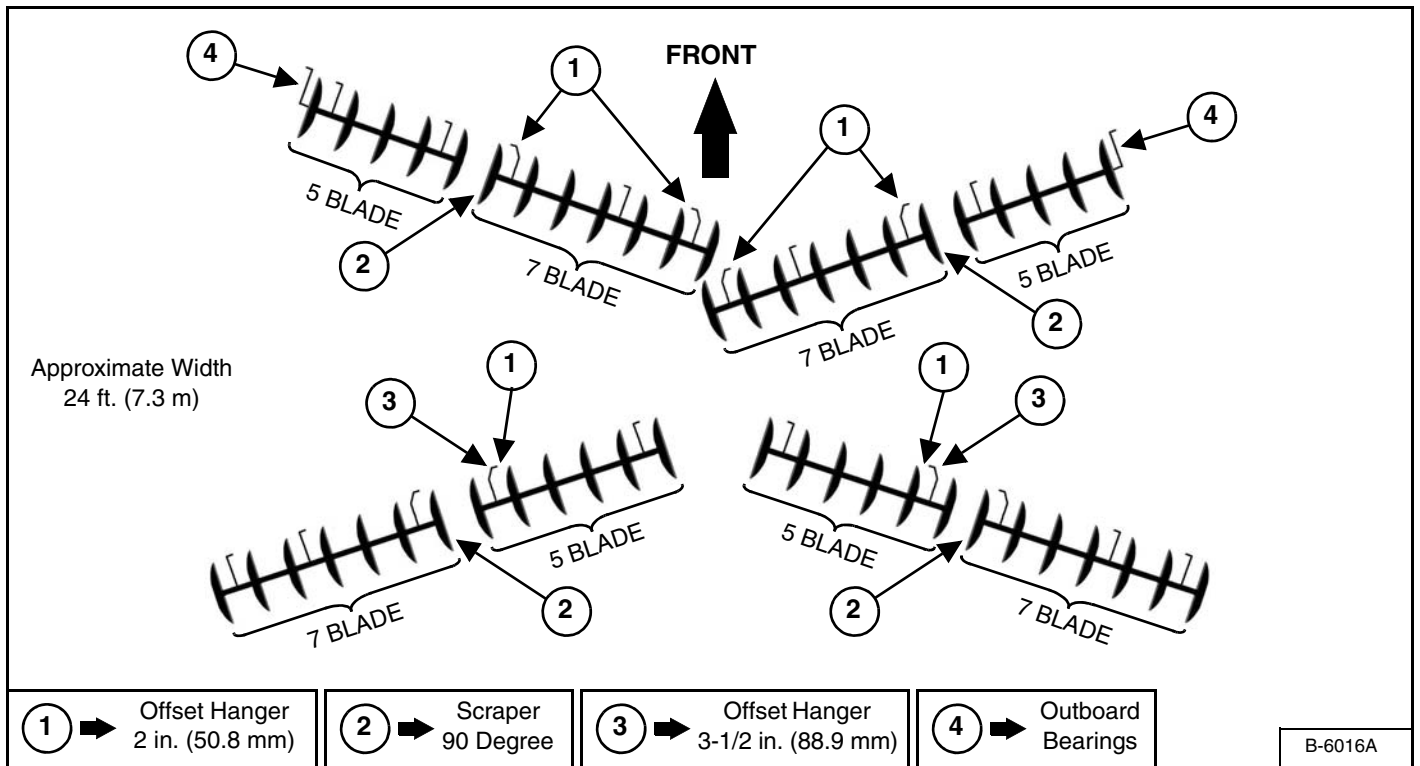

12 Inch Spacing - 54 Blades / 20 Bearings

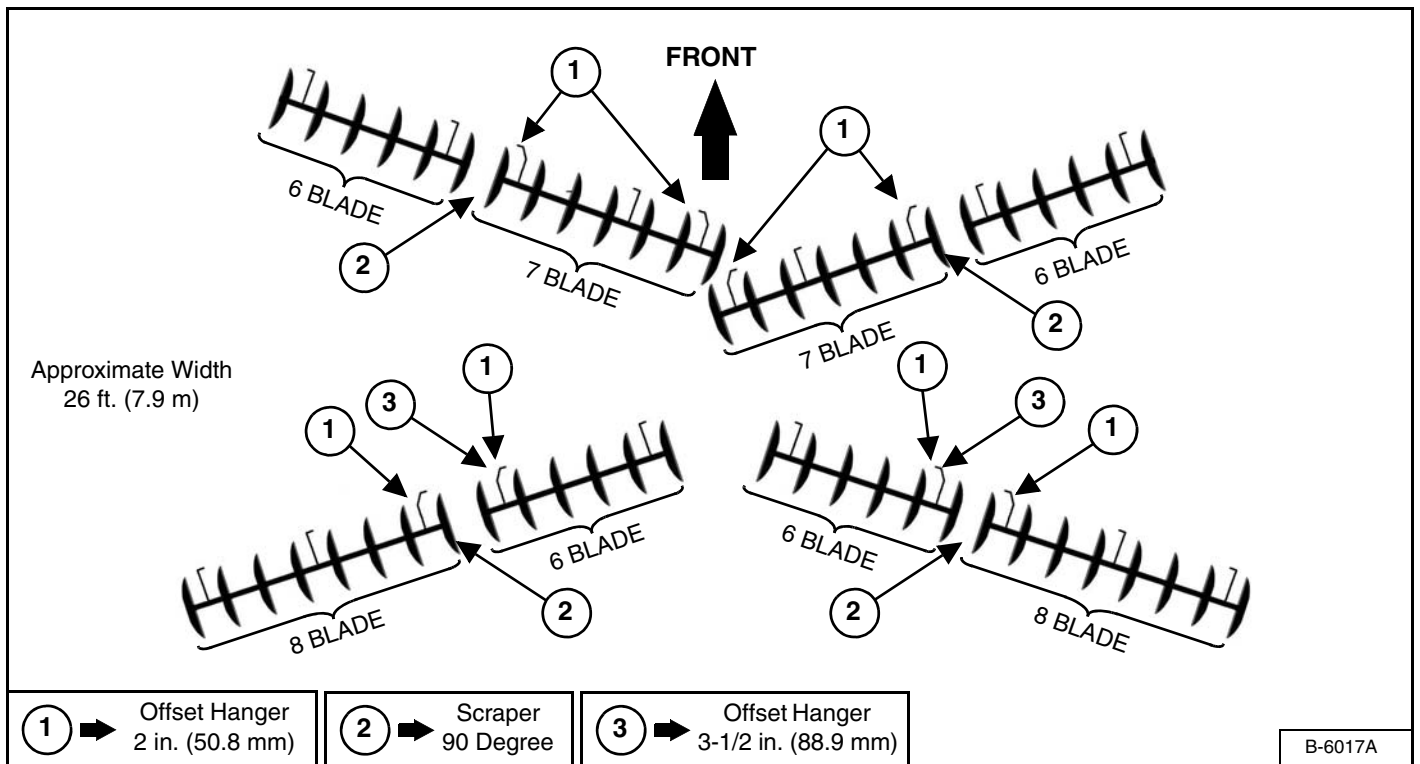

GANG PATTERNS (CONT'D)

12 Inch Spacing - 66 Blades / 24 Bearings

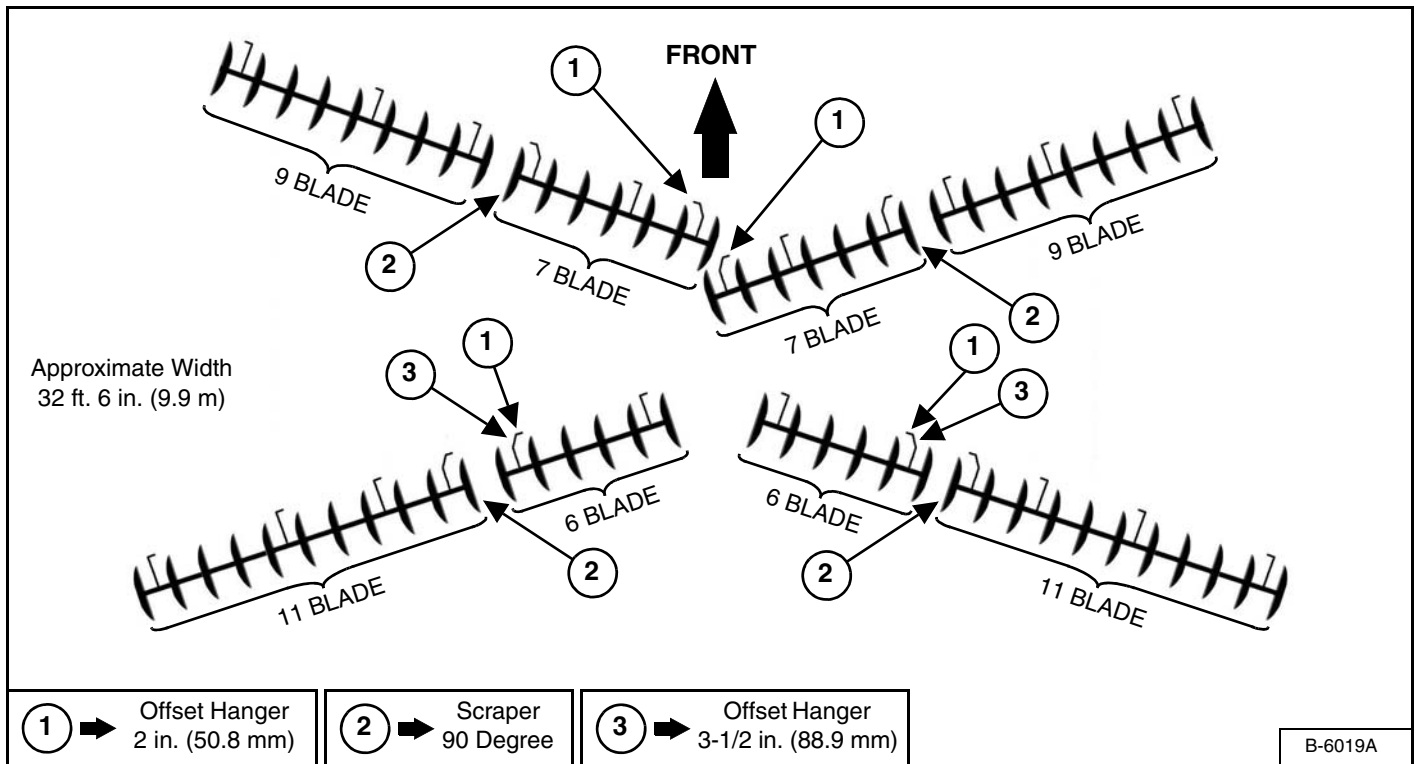

12 Inch Spacing - 74 Blades / 26 Bearings

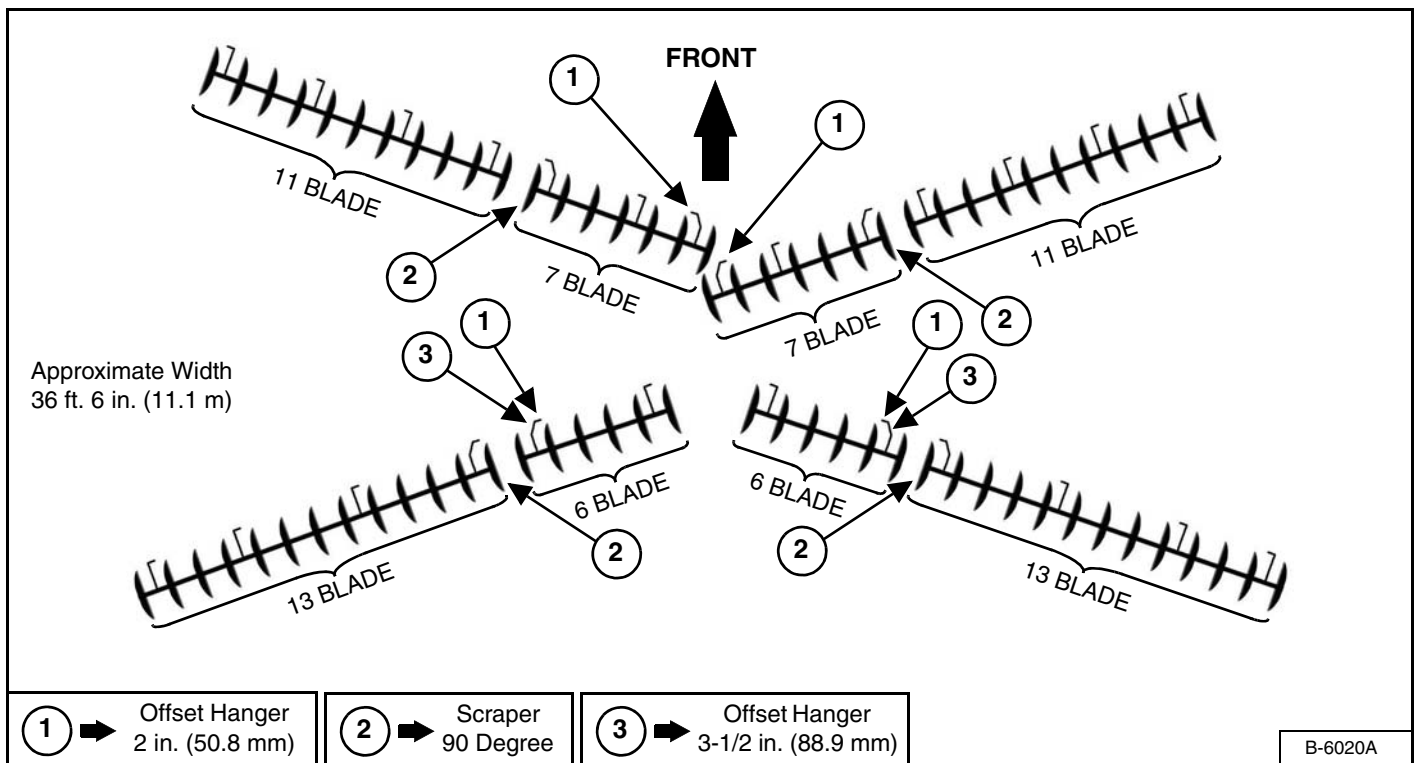

GANG PATTERNS (CONT'D)

12 Inch Spacing - 78 Blades / 28 Bearings

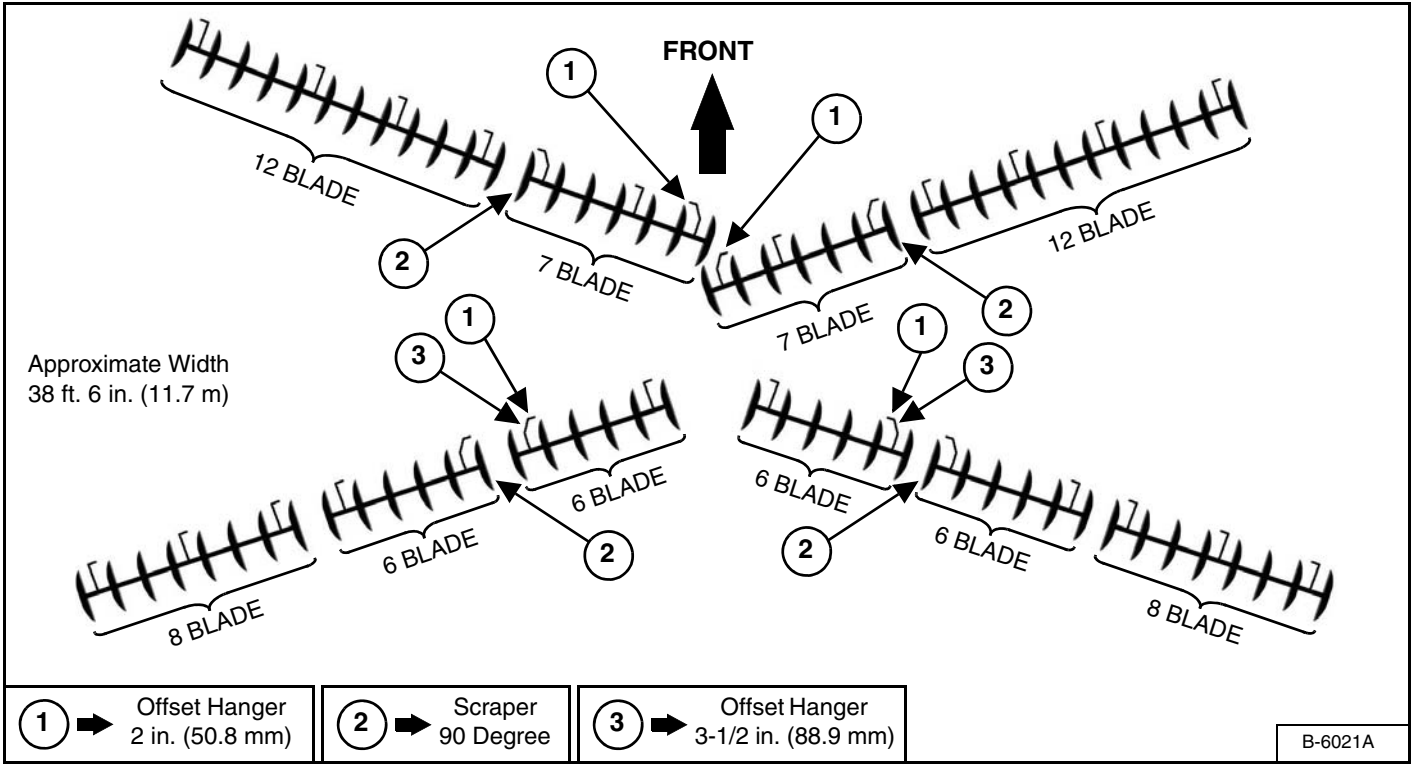

OPERATION

GENERAL INFORMATION	91
Pre - Operation Checklist	91
Break - In Checklist	92
Tractor Requirements	93
Entering And Leaving The Operator's Position	93
INITIAL SET-UP	94
Connecting The Tandem Disc To The Tractor	94
Connecting Hydraulic Lines	95
Connect Electrical Harness	96
Lateral Adjustment	97
Front To Rear Adjustment	99
Setting Discing Depth	99
Leveling Wing Frames	100
OPERATING THE TANDEM DISC	101
Field Operation	101
Rephasing Rockshaft Cylinders	103
ADDITIONAL OPERATING RECOMMENDATIONS	103
Remove Ridge At Center Of Disc	103
Remove Furrow At Center Of Disc	103
Remove Unbroken Ground Left By Front Gangs	103
Reduce Gang Plugging	103
TRANSPORTING	104
Requirements	104
Transport Position	104

Farm King



GENERAL INFORMATION

Pre - Operation Checklist

Before operating the Tandem Disc for the first time and each time thereafter, check the following items:



MOVING PART HAZARD

To prevent serious injury or death from moving parts:

- Clear area of all bystanders before starting or moving the tractor and disc.
- Keep hands, feet, hair and clothing away from moving parts.
- Disconnect and lockout power source before adjusting or servicing.
- Do not stand or climb on machine when operating.



AVOID INJURY OR DEATH

Wear safety glasses to prevent eye injury when any of the following conditions exist:

- When fluids are under pressure.
- Flying debris or loose material is present.
- Engine is running.
- Tools are being used.

1. Lubricate the equipment per the schedule outline in the Maintenance Section. (See "SERVICE SCHEDULE" on page 109.)
2. Check the Tandem Disc hitch for damaged, loose or missing parts. Repair as needed before operation.

3. Check center frame tire pressure (See minimum - maximum tire pressure on the tire side wall).
4. Check wing frame tire pressure (See minimum - maximum tire pressure on the tire side wall).
5. Check that wheel bolt torque is 130 ft-lb (176.3 N•m).
6. Fully clean the equipment. (See "CLEANING THE TANDEM DISC" on page 117.)
7. Check tandem disc for damaged or loose components and hardware. Replace damaged components (if required) and tighten all hardware before operating the tandem disc.
8. Check wings for proper operation. Adjust wings as needed before operating the tandem disc.
9. Inspect all electrical connections to ensure proper function of the machine.
10. Inspect all safety reflective decals, slow moving vehicle decals and lights where applicable.



Leaking fluids under pressure can enter the skin and cause serious injury or death. Immediate medical attention is required. Wear goggles. Use cardboard to check for leaks.

11. Check condition of all hydraulic components for leaks. Repair as required.

NOTE: Do not operate with hydraulic leaks.

12. Verify that the tandem disc is properly connected to the tractor with the safety chain.

Break - In Checklist

Check the following mechanical items after 1 hour of operation and again after 10 hours of operation:

1. Check condition of all hydraulic components for leaks. Tighten fittings to correct leaks or replace components. Do not operate with hydraulic leaks.

Figure 121

2. Check the tandem disc hitch for damaged, loose or missing parts [Figure 121]. Repair as needed before operation.
3. Check for loose fasteners and hardware. Tighten as required.
4. Check center frame tire pressure (See minimum - maximum tire pressure on the tire side wall).
5. Check wing frame tire pressure (See minimum - maximum tire pressure on the tire side wall).
6. Check that wheel bolt torque is 130 ft-lb (176.3 N•m).

**IMPORTANT**

Wheel bolts must be kept tight. If bolts are not tight, bolts will loosen causing severe damage to hub, wheel and tire. Check wheel bolts periodically, especially the first few hours of either transport or field work.

Tractor Requirements



AVOID SERIOUS INJURY OR DEATH

The tractor must be equipped with an approved Roll Over Protection Structure (ROPS) and safety belts to help prevent personal injury or death caused by tractor roll over.



- Keep shields and all guards in place.
- Keep away from moving parts.
- Keep bystanders away.

NOTE: The following information will depend on working depth, soil type, field speed, etc.

10.5 in. (267 mm) Spacing

The 8700 Tandem Disc with 10.5 in. (267 mm) spacing will require a tractor with minimum 7.0 to 8.0 DBHP/foot (5.2 to 6.0 kW per 305 mm).

12 in. (305 mm) Spacing

The 8700 Tandem Disc with 12 in. (305 mm) spacing will require a tractor with minimum 7.0 to 8.0 DBHP/foot (5.2 to 6.0 kW per 305 mm).

Entering And Leaving The Operator's Position

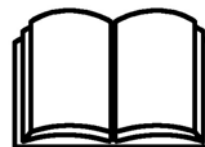

Follow the instructions in your tractor's operation manual for the correct procedure.

Entering The Operator's Position

Move to the operator's position, start the engine and release the parking brake.

Leaving The Operator's Position



AVOID INJURY OR DEATH

Before you leave the operator's position:

- Always park on a flat level surface.
- Place all controls in **NEUTRAL**.
- Engage the park brake.
- Stop the engine and remove the key.
- Wait for all moving parts to stop.

Park the tractor / equipment on a flat level surface.

Place all controls in neutral, engage the park brake, stop the engine and wait for all moving parts to stop. Leave the operator's position.

INITIAL SET-UP

Connecting The Tandem Disc To The Tractor

Always inspect the tractor’s drawbar and tandem disc hitch before connecting. See the tractor’s owner’s manual.

Enter the operator’s position. (See “Entering The Operator’s Position” on page 93.)

Move the tractor into position in front of the Tandem Disc.



AVOID INJURY OR DEATH

Before moving the tractor, look in all directions and make sure no bystanders, especially small children are in the work area. Do not allow anyone between the tractor and the equipment when backing up to the equipment for connecting.

Move the tractor backwards, aligning the drawbar with the tandem disc hitch.

NOTE: The jack may need to be lowered or raised for proper alignment of the drawbar and hitch.

If the tandem disc hitch needs to be adjusted, stop the tractor when drawbar is just in front of the Tandem Disc hitch.

Leave the operator’s position. (See “Leaving The Operator’s Position” on page 93.)

Figure 122

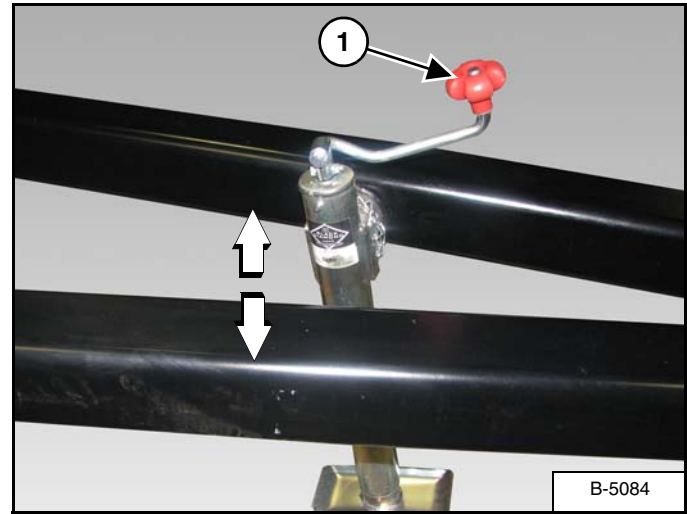

Turn the handle (Item 1) [Figure 122] clockwise to raise the hitch or counterclockwise to lower the hitch.

Lower or raise the Tandem Disc hitch until aligned with the tractor’s drawbar.

Move to the operator’s seat, start the engine and release the parking brake.

Move the tractor backwards, aligning the drawbar hitch pin hole with the Tandem Disc hitch pin hole(s).

Stop the tractor and leave operator’s position.



AVOID INJURY OR DEATH

Keep fingers and hands out of pinch points when connecting and disconnecting equipment.

NOTE: Always use a hitch pin of adequate size and strength and a retaining pin with a locking device.

Figure 123

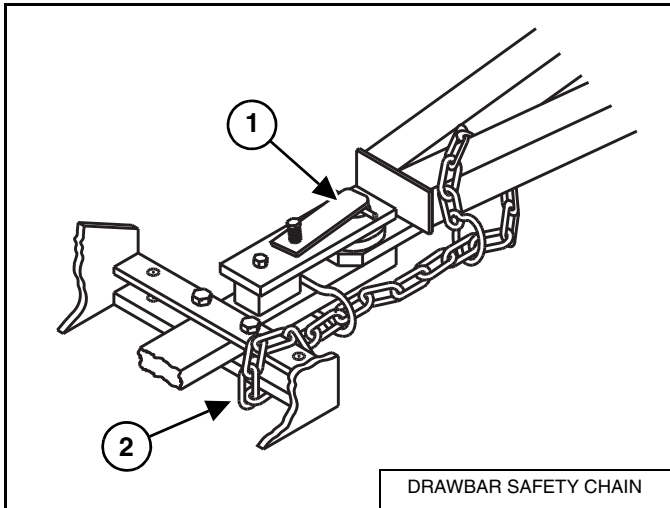

Install the hitch pin (Item 1) [Figure 123] and retaining pin to securely fasten the Tandem Disc hitch to the tractor drawbar.

Attach the safety chain (Item 2) [Figure 123] around the drawbar.

NOTE: Always use a safety chain with a strength rating greater than the gross weight of the towed machine.

Connecting Hydraulic Lines



HIGH PRESSURE FLUID HAZARD

To prevent serious injury or death from high pressure fluid:

- Relieve pressure on system before repairing or adjusting.
- Wear proper hand and eye protection when searching for leaks. Use wood or cardboard instead of hands.
- Keep all components in good repair.



- Contain and dispose of any oil leakage in an environmentally safe manner.
- Thoroughly clean the quick couplers before making connections. Dirt can quickly damage the system.

NOTE: Make sure the quick couplers are fully engaged. If the quick couplers do not fully engage, check to see that the couplers are the same size and type.

To Connect:

Figure 124

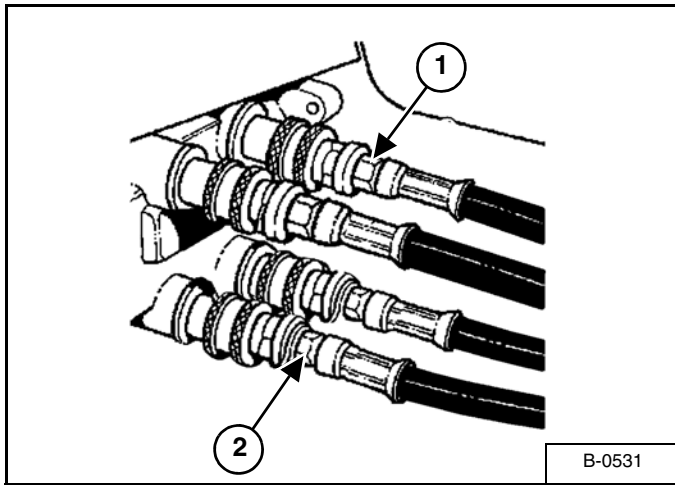

Connect the hydraulic lines to the tractor **[Figure 124]**.

1. Raise / Lower (Green Ties).
2. Fold / Unfold (Blue Ties).

To Disconnect:



AVOID BURNS

Hydraulic fluid, tubes, fittings and quick couplers can get hot when running equipment. Be careful when connecting and disconnecting quick couplers.

Pull on the hydraulic lines to disconnect.

Connect Electrical Harness

Connect the tandem disc's lighting harness to the tractor's electrical system.

Lateral Adjustment



The tandem disc frame must be leveled front to rear & side to side until the tandem disc is parallel with the ground prior to operation.



AVOID INJURY OR DEATH

Wear safety glasses to prevent eye injury when any of the following conditions exist:

- When fluids are under pressure.
- Flying debris or loose material is present.
- Engine is running.
- Tools are being used.

Move to the operator's position, start the engine and release the parking brake. (See "Entering The Operator's Position" on page 93.)

Park the tractor / equipment on a flat level surface.

Stop the tractor, place all controls in neutral, engage the park brake, stop the engine and wait for all moving parts to stop. Leave the operator's position. (See "Leaving The Operator's Position" on page 93.)

Front Gangs

Figure 125

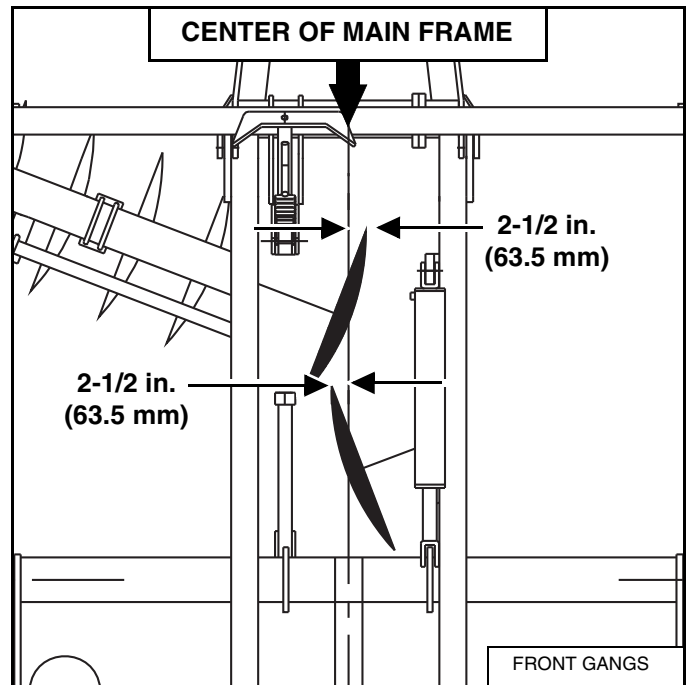

Loosen bearing hanger U-bolts and position the front inside gang sections, so that the leading edge of inside blade is approximately 2-1/2" (63.5 mm) past center of main frame [Figure 125].



Always tighten inside hanger bearing u-bolts first, while maintaining the 2-1/2" (63.5 mm) spacing past center of main frame. Tighten all bearing hanger u-bolts to 430 ft.-lb. (583 N•m) torque.



Hanger bracket must be sitting square with gang beam before tightening u-bolts.

Rear Gangs

! IMPORTANT

The opening between the rear gang must be set at a distance that will allow furrow left by the front gangs to be filled evenly.

NOTE: The distance the rear gangs are set apart is determined by the discing speed, discing depth, gang angle and soil conditions. If the rear gangs are set too close together, the rear gangs will leave a ridge at center. If rear gangs are set too far apart, the furrow at center left by the front gangs will not be filled.

Figure 126

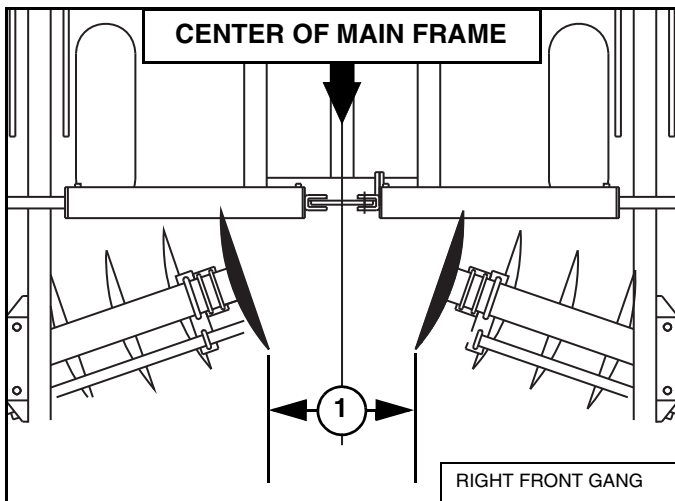

Center rear inside gang sections, so that the distance between the rear edge of the two inside blades (Item 1) [Figure 126], is equal to 2" (50.8 mm) less than diameter of blades with a maximum of 24" (610 mm).

EXAMPLE - if the disc is equipped with 24" (610 mm) diameter blades, the distance between the rear edge of the two inside blades (Item 1) [Figure 126] would be set at 22" (559 mm).

NOTE: If the disc is equipped with 26" (660 mm) or 28" (711 mm) diameter blades, the distance between the rear edge of the two inside blades (Item 1) [Figure 126] would be set at a maximum of 24" (610 mm).

To adjust the distance between the rear gangs, loosen the bearing hanger u-bolts and reposition the gang sections.

NOTE: It may be necessary to increase distance between rear gangs in order to collect enough soil to fill furrow.

An increase in discing speed may require rear gangs to be set further apart. A decrease in discing speed may require rear gangs to be set closer together.

! IMPORTANT

Be sure the blade to blade distance between individual gangs are adjusted to match discs blade spacing.

Front And Rear Gang Adjustments Completed

! IMPORTANT

Always tighten inside hanger bearing u-bolts first, while maintaining the desired spacing between the rear edge of the two inside blades. Tighten all bearing hanger u-bolts to 430 ft.-lb. (583 N•m) torque.

NOTE: Before tightening bearing hanger U-bolts, ensure that each bearing hanger is positioned flat under the gang beam to avoid preloading bearings and / or other gang components.

Tighten bearing hanger u-bolts.

Front To Rear Adjustment

Move to the operator’s position. (See “Entering The Operator’s Position” on page 93.)

Park the tractor / equipment on a flat level surface.

Stop the tractor and leave the operator’s position. (See “Leaving The Operator’s Position” on page 93.)

Lowering / Raising The Front Gangs



Always keep disc level from front to rear. Discing with front gangs lower than rear gangs will cause ridging at outside and may cause damage to disc components.

Figure 127

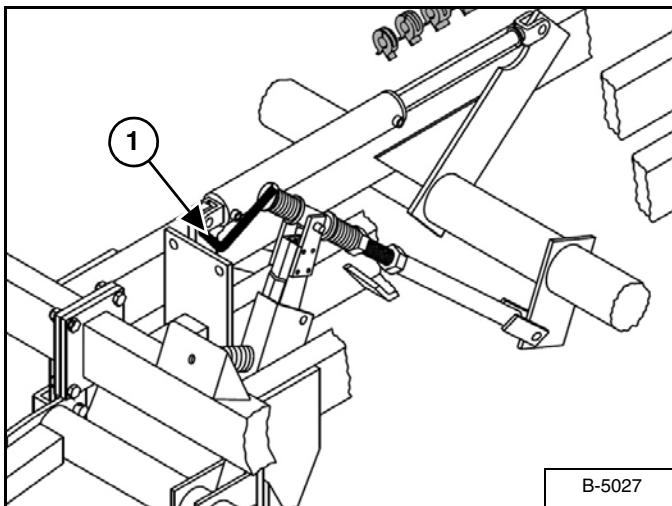

Lowering Front Gangs - Turn crank, (Item 1) [Figure 127], IN (clockwise)

Raising Front Gangs - Turn crank, (Item 1) [Figure 127], OUT (counter clockwise)

Setting Discing Depth

Move to the operator’s position. (See “Entering The Operator’s Position” on page 93.)

While moving forward, lower disc into the ground until disc reaches desired discing depth.

Stop the tractor and leave the operator’s position. (See “Leaving The Operator’s Position” on page 93.)



To keep disc level, transport wheels must be riding on ground gauging desired discing depth.

Figure 128

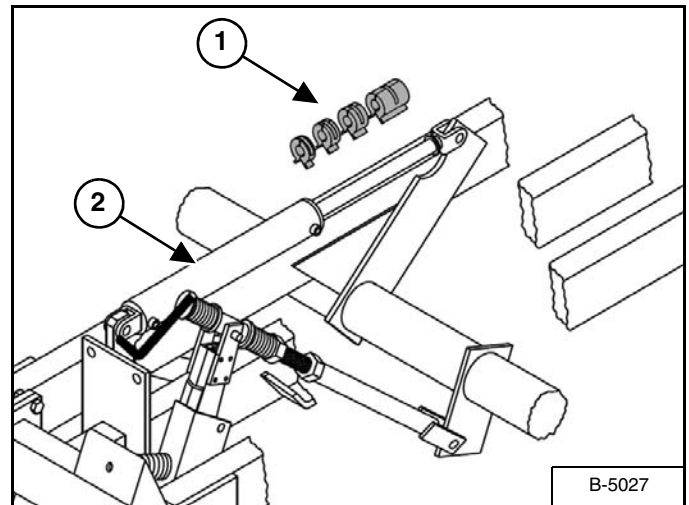

Install the necessary depth control stops (Item 1) on center frame cylinder (Item 2) [Figure 128] to maintain the desired cutting depth.

Leveling Wing Frames

Move to the operator's position. (See "Entering The Operator's Position" on page 93.)

Move the tractor / equipment to a flat level surface.

Stop the tractor and leave the operator's position. (See "Leaving The Operator's Position" on page 93.)

! IMPORTANT

Before leveling wing frames, verify center frame is level from front to rear.

! IMPORTANT

For even blade penetration, outside of wing frames must be level with center frame or even 1/2 in. (12.7 mm) higher than center frame.

Raising Outside Wing Frame

Figure 129

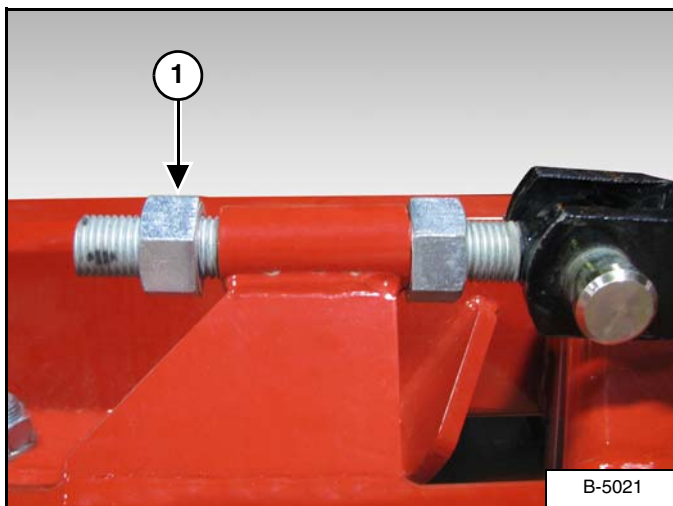

Loosen rear nut (Item 1) [Figure 129] of I-bolt and tighten front nut. This will lower the wheels, raising outside of wing.

After adjustments are complete, lock I-bolt by tightening rear nut against I-bolt holder.

Lowering Outside Wing Frame

Figure 130

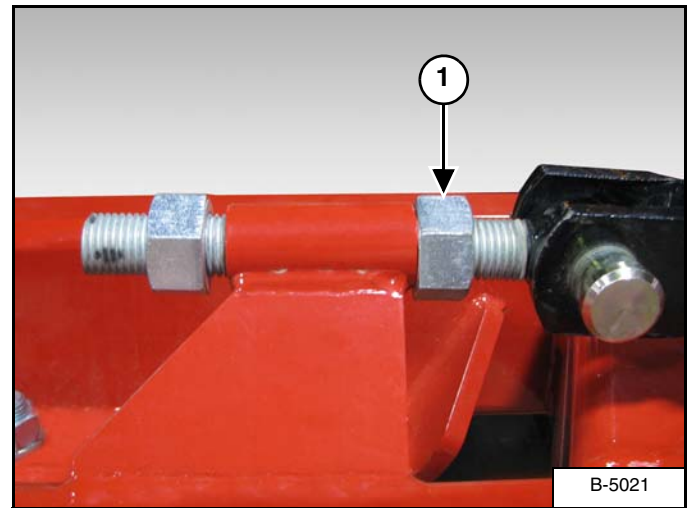

Loosen front nut (Item 1) [Figure 130] of I-bolt and tighten rear nut. This will raise the wheels allowing outside of wing to lower.

After adjustments are complete, lock I-bolt by tightening rear nut against I-bolt holder.

! IMPORTANT

Verify that the axis of clevis pin is horizontal and cylinder ports are facing up. If cylinder and I-bolt are not positioned properly, cylinder will not be free to pivot when activated, causing serious damage.

! CAUTION

If cylinder and I-bolt are not positioned properly, cylinder will not be free to pivot when activated, causing serious damage.

OPERATING THE TANDEM DISC

Field Operation

Move to the operator’s position, start the engine and release the parking brake. (See “Entering The Operator’s Position” on page 93.)

Move the tractor / equipment to the starting point of the work area.

Stop the tractor and engage the parking brake.

Stop the tractor and leave the operator’s position. (See “Leaving The Operator’s Position” on page 93.)

Make lateral adjustments (if required). (See “Lateral Adjustment” on page 97.)

Level wing frames (if required). (See “Leveling Wing Frames” on page 100.)

Set discing depth (if required). (See “Setting Discing Depth” on page 99.)



ELECTROCUTION HAZARD

To prevent serious injury or death from electrocution:

- Be aware of overhead / underground powerlines.
- Keep away from powerlines when transporting or folding / unfolding wings.
- Electrocution can occur without direct contact.



AVOID SERIOUS INJURY OR DEATH

- Do not stand under wings when folding / unfolding.
- Keep bystanders away.

NOTE: When extending wing lift cylinders, there will be a short pause before cylinders fully extend.

Using the tractor controls, lower wings until the wing wheels make contact with the ground. Continue to hold the tractor control until the wing lift cylinders are fully extended, placing the wings in the field position.

Move to the operator’s position, start the engine and release the parking brake. (See “Entering The Operator’s Position” on page 93.)



AVOID SEVERE EQUIPMENT DAMAGE

When operating the tandem disc:

- Always keep disc level when operating.
- Do not make sharp turns with the disc in ground.
- Always lift the disc out of ground before making sharp turns.
- Do not operate disc in field with wings folded in transport position.
- Do not disc with front gangs cutting deeper than rear gangs.
- Always place the hitch jack in the horizontal / transport position when operating.
- Always keep transport wheels in contact with the ground.
- Always operate the disc with the tractor drawbar pinned at center of tractor.



MACHINE TIPPING OR ROLL OVER CAN CAUSE SERIOUS INJURY OR DEATH

- Turn on level ground. Slow down when turning.
- Go up and down slopes, not across them.
- Check for adequate traction.

Recommended operating speed is 5 - 7 mph (8 - 11 kph).

Move tractor and tandem disc forward, slowly lower tandem disc into the ground until the transport wheels make contact with the ground and the disc reaches desired discing depth.

Figure 131

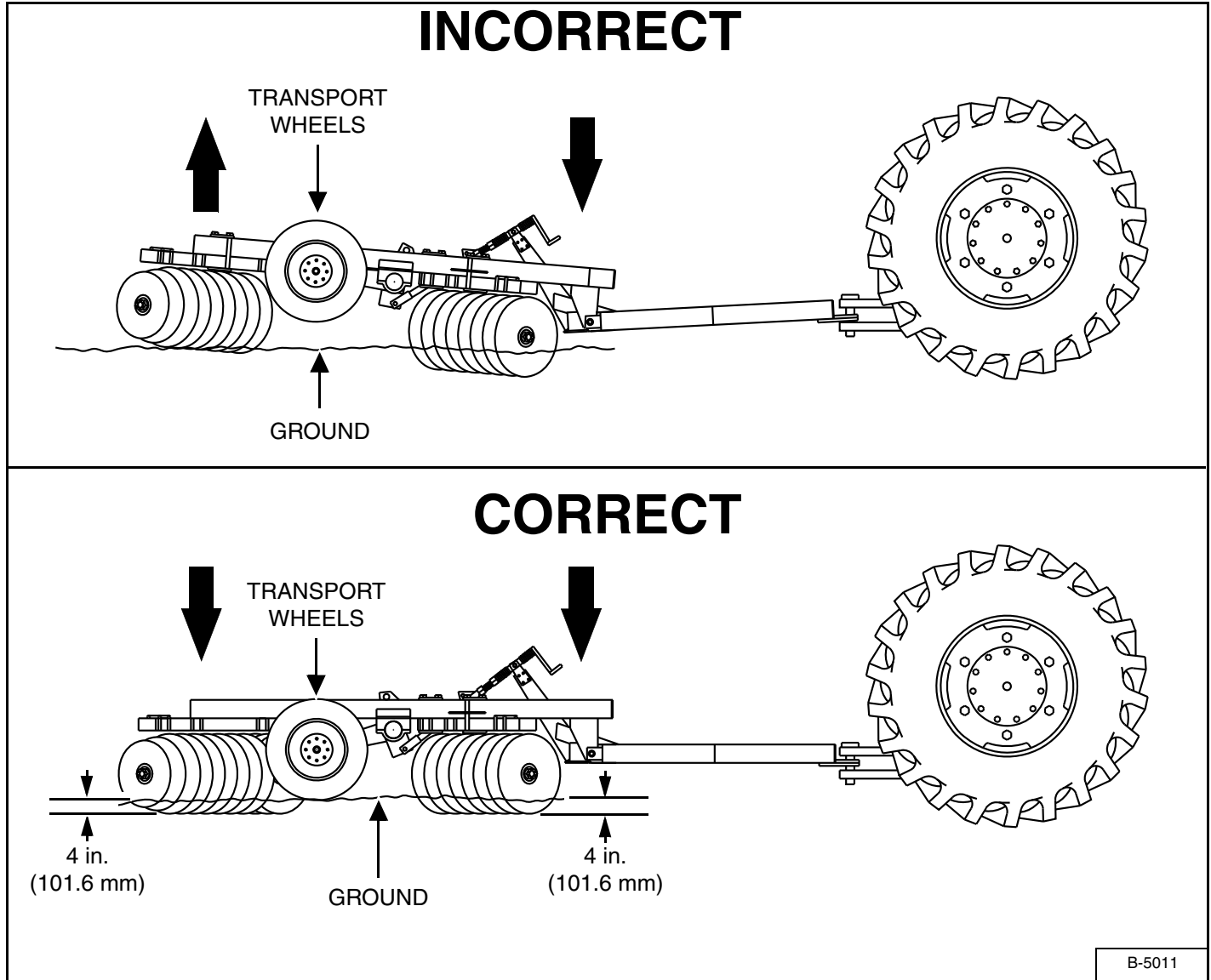

To keep the tandem disc level, transport wheels must be contacting the ground gaging desired discing depth (CORRECT) [Figure 131].

NOTE: If conditions are such that disc cannot penetrate to maximum depth, Do Not raise transport wheels off ground (INCORRECT) [Figure 131]. Raised transport wheels may cause front of disc to drop causing front gangs to cut deeper than rear gangs.

Uneven And Deep Front Gang Penetration

- Front of disc may drop because rockshaft and hitch leveling arm is linked. As the wheels are raised, the hitch leveling arm is pulled back allowing hitch to float. If hitch is allowed to float it will not support front of disc allowing front gang to drop.
- With front of disc lower than the rear, the front outside blades will cut much deeper than the front inside blades. This means that more of the disc's weight is placed on the front outside blades, forcing them deeper into the ground.
- Uneven and deep front gang penetration in tough conditions will place excessive strain on blades, gang bearings, frame and hitch, and will lead to a premature failure of parts especially outside blades and bearings of front gangs.

IMPORTANT
AVOID EQUIPMENT DAMAGE

Operating disc with transport wheels off ground will cause uneven discing and place undue strain on machine which could lead to parts failure. Always operate disc with transport wheels on ground even if soil conditions will not allow disc to penetrate to maximum depth.

Rephasing Rockshaft Cylinders

NOTE: Periodically, the hydraulic lift cylinders on wing frame will not be synchronized with center frame cylinder. This will cause uneven cutting depth. If this happens, rephase the lift cylinders.

Procedure

Fully lift the tandem disc completely out of the ground, continue holding the tractor's control lever until all (3) three rockshaft cylinders are fully extended.

ADDITIONAL OPERATING RECOMMENDATIONS**Remove Ridge At Center Of Disc**

Make one or more of the following adjustments:

- Level disc from front to rear using leveling crank.
- Increase discing speeds.
- Increase distance between rear gangs.

Remove Furrow At Center Of Disc

Make one or more of the following adjustments:

- Level disc from front to rear using leveling crank.
- Reduce discing speeds.
- Decrease distance between rear gangs.

Remove Unbroken Ground Left By Front Gangs

Make the following adjustment:

- Adjust leading edge of inside blade of each front gang so it is 2-1/2 in. (63.5 mm) past center of disc.

Reduce Gang Plugging

Make the following adjustment:

- Adjust scrapers so they contact blades.

TRANSPORTING

Requirements

Comply with federal, state, local and provincial laws regarding the transport of farm equipment on public roadways.



AVOID SERIOUS INJURY OR DEATH

Use of an unapproved hitch or tractor can result in loss of control, leading to serious injury or death.

Tractor and hitch must have the rated capacity to tow equipment.



AVOID SERIOUS INJURY OR DEATH

Excess weight will greatly increase tractor stopping distance and may cause the operator to lose control of the tractor.



Tractor must have adequate braking capacity to safely control tandem disc GVW (Gross Vehicle Weight) trailing load. Do not tow over 20 mph (32 kph). Tractor unit should weigh approximately 67% of GVW.

Verify that the tractor is approved for transporting the equipment and that the equipment is securely attached to the tractor.

Verify safety chain is installed and properly connected before transporting equipment.

Verify that the SMV (Slow Moving Vehicle) emblem, all lights and reflectors are clean and visible.

Figure 132

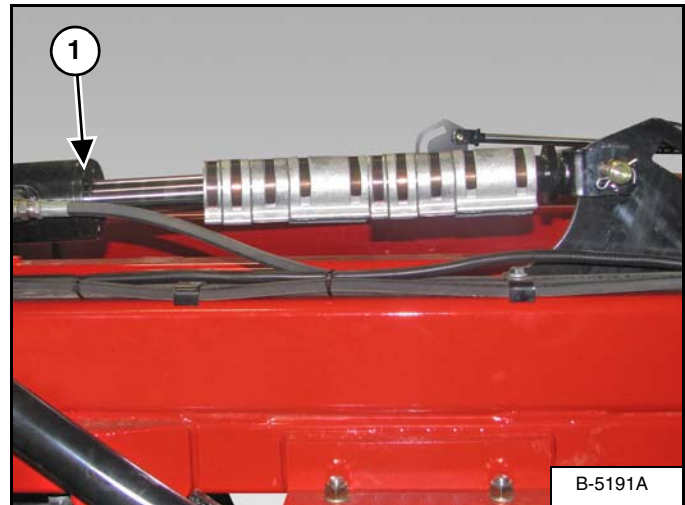

When transporting disc, always place the complete depth control package 17 in. (431.80 mm) long on shaft of 4 in. x 24 in. (102 mm x 610 mm) main frame lift cylinder (Item 1) [Figure 132].

Transport Position

Wings fully raised, depth control package in place and lockup valves in closed position.



All depth stops must be installed and lock up valves closed when transporting disc.

MAINTENANCE

TRUBLESHOOTING	107
General Chart	107
SERVICE SCHEDULE	109
Maintenance Intervals	109
LUBRICATION	110
Recommendations	110
Locations	110
BEARING HANGERS	113
Inspection	113
LEVELING CRANK	113
Inspection	113
GANG SECTION	114
Gang Bolt Inspection	114
Tightening Gang Bolt	114
AXLES	115
Wheel Bolts Torque	115
Tire / Wheel Replacement	115
Wheel Bearings	116
Tire Pressure	116
CLEANING THE TANDEM DISC	117
SERVICING T2-215 BEARINGS (IMPORTANT NOTES)	117
WING LIFT CYLINDER	117
Removal And Installation	117
WALKING BEAMS	118
Installing The Walking Beams	118
HITCH COMPRESSION SPRING	122
FRAME SPRING BUSHINGS	122
Removal And Installation	122
ROCKSHAFT SPRING BUSHINGS	123
Removal And Installation	123

SCRAPER BARS123
 Removal And Installation123

SAFETY SIGN (DECAL) INSTALLATION124
 Procedure124

STORAGE AND RETURN TO SERVICE125
 Storage125
 Return To Service125

TROUBLESHOOTING

General Chart



Instructions are necessary before operating or servicing equipment. Read and understand the Operator And Parts Manual and safety signs (decals) on equipment. Follow warnings and instructions in the manuals when making repairs, adjustments or servicing. Check for correct function after adjustments, repairs or service. Untrained operators and failure to follow instructions can cause injury or death.

NOTE: If a problem is encountered that is difficult to solve, even after having read through this troubleshooting section, please call your local distributor or dealer. Before you call, please have this Operator And Parts Manual and the serial number of your machine at hand.

PROBLEM	CAUSE	CORRECTION
Outside blades of front wings are cutting too deep causing disc to ridge at outside.	Wheels raised off ground causing front disc to drop.	Lower wheels to ground to gauge discing depth.
	Tire pressure is low on outer wheels causing disc to cut deep at outside.	Inflate tire, (See "Tire Pressure" on page 116.)
	Disc is lower at front than at rear.	Using leveling crank, raise front of disc.
	Wing wheel not adjusted for proper cutting depth.	Raise outside of wing by adjusting lift cylinder I-bolt.
	Wing rockshaft cylinders are not synchronized with center frame rockshaft cylinder.	Rephase rockshaft cylinders.
Outside blades of front wings are not cutting deep enough.	Disc is higher at front than rear.	Using leveling crank, raise front of disc.
Outside blades on front and rear gangs are cutting too deep.	Tire pressure is low for wing wheels causing wings to cut deeper.	Check tire inflation for all wheels. (See "Tire Pressure" on page 116.)
	Outside of wing frame is lower than main frame.	Raise outside of wing with wing rockshaft cylinder anchor bolt.
	Wing rockshaft cylinders are not synchronized with center frame rockshaft cylinder.	Rephase rockshaft cylinders.
Outside blades on front and rear gangs are not cutting deep enough.	Tire pressure is lower on center section wheels than wing section wheel causing center section to cut deeper.	Check tire inflation for all wheels. (See "Tire Pressure" on page 116.)
	Outside of wing frame(s) is higher than main frame.	Lower outside of wing with wing rockshaft cylinder anchor bolt.
	Wing rockshaft cylinder is not synchronized with main frame rockshaft cylinder.	Rephase rockshaft cylinders.

PROBLEM	CAUSE	CORRECTION
Disc is leaving a ridge at center of discing	Rear gangs are cutting deeper than front gangs.	Level disc.
	High discing speed is causing disc to throw dirt further resulting in a pile at center.	Decrease discing speed.
	Rear gangs are too close together.	Increase distance between rear gangs.
Rear gangs are not filling furrow left by front gangs at center of disc.	Front gangs are cutting deeper than rear gangs.	Level disc.
	A low discing speed is causing disc to not throw dirt far enough to fill furrow left by front center blades.	Increase discing speed.
	Rear gangs are too far apart.	Decrease distance between rear gangs.
Front gangs are leaving unbroken ground at center of disc.	Front gangs are either overlapped too much or not enough.	Adjust overlap of front gangs.
Disc gangs are plugging.	Scrapers are too far from blades.	Adjust scrapers so they are contacting blades.
	Thrash conditions too heavy for your machine cylinder(s).	Contact your dealer.
When raising disc out of ground, main frame comes out of ground while outside of wing(s) lags behind or does not come out of ground.	Piston seals on wing rockshaft cylinder(s) are damaged.	Replace piston seals of wing rockshaft cylinder.
When raising disc out of ground, main frame rockshaft cylinder is fully extended while wing rockshaft cylinder(s) are not fully extended.	Rockshaft cylinders not synchronized.	Rephrase rockshaft cylinders.
When raising disc out of ground wing rockshaft cylinder is fully extended while main frame rockshaft cylinder(s) are not fully extended.	Rockshaft cylinders not synchronized.	Rephrase rockshaft cylinders.
Outer wing blades will not penetrate soil.	Soil condition too hard for your machine.	Add weights to outside of wing frame. Contact your Dealer for available weights.
All section of disc will not penetrate soil.	Soil condition too hard for your machine.	Contact your Dealer.

SERVICE SCHEDULE

Maintenance Intervals

Maintenance work must be done at regular intervals. Failure to do so will result in excessive wear and early failures. The service schedule is a guide for correct maintenance of the 8700 Tandem Disc.



Instructions are necessary before operating or servicing equipment. Read and understand the Operator and Parts Manual and safety signs (decals) on equipment. Follow warnings and instructions in the manuals when making repairs, adjustments or servicing. Check for correct function after adjustments, repairs or service. Untrained operators and failure to follow instructions can cause injury or death.

#	DESCRIPTION	SERVICE PROCEDURES						
		Check	Clean	Lube	Change	Adjust	Drain	Locations
Daily Maintenance (or every 8 hours)								
1	Tire Pressure	•						page 116
2	Wheel Bolts	•						page 115
3	Hydraulic Cylinders	•						-
4	Gang Bolts	•						-
5	Bearing Bolts	•						page 113
6	Bearing Hanger U-Bolts	•						page 113
Every 2 Days (or every 20 hours)								
7	Gang Bearings			•				page 110
8	Rockshaft Bearings (Top & Bottom)			•				page 111
Weekly (or every 50 hours)								
9	Axle Bearing	•		•				page 111
10	Walking Axles	•		•				page 111
11	Rockshaft Hydraulic Cylinder Pins	•		•				page 112
Monthly (or every 100 hours)								
12	Leveling Crank	•		•				page 112
13	Wing Hinge Points	•		•				page 112
Annually (or every 500 hours)								
14	Leveling Crank Ball Joint	•		•				page 112
15	Wheel Bearings	•		•				page 116

LUBRICATION

Recommendations

Always use a good quality multi-purpose / lithium base grease when lubricating the equipment.

! IMPORTANT

If bearings are over lubricated, there is a possibility the seals can be pushed out. T2-215 series bearings have internal seals that can not be over lubricated.

- Always use a hand-held grease gun.
- Clean fitting before greasing to avoid injecting dirt and grit.
- Replace and repair broken fittings immediately.
- If fittings will not take grease, remove and clean thoroughly. Replace fitting if necessary.

Locations

! IMPORTANT

Fluid such as engine oil, hydraulic fluid, coolants, grease, etc. must be disposed of in an environmentally safe manner. Some regulations require that certain spills and leaks on the ground must be cleaned in a specific manner. See local, state and federal regulations for the correct disposal.

Lubricate the following grease locations **EVERY 20 HOURS:**

Figure 133

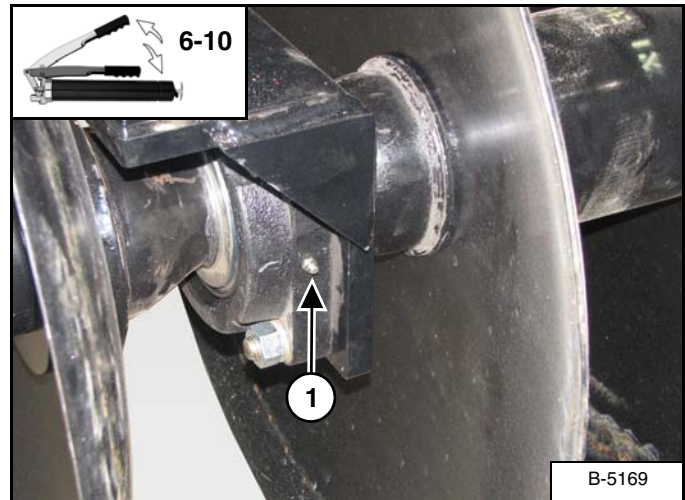

Apply six - ten pumps of grease to the gang bearings (Item 1) [Figure 133] (all locations).

Lubricate the following grease locations **EVERY 20 HOURS:**

Figure 134

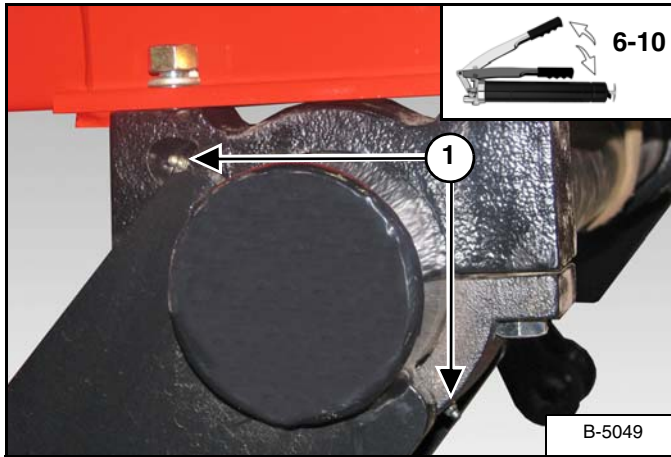

Apply six - ten pumps of grease to the rockshaft bearings (Item 1) [Figure 134] (all locations).



Lower disc so gangs are resting on ground before greasing rockshaft bearings.

Figure 135

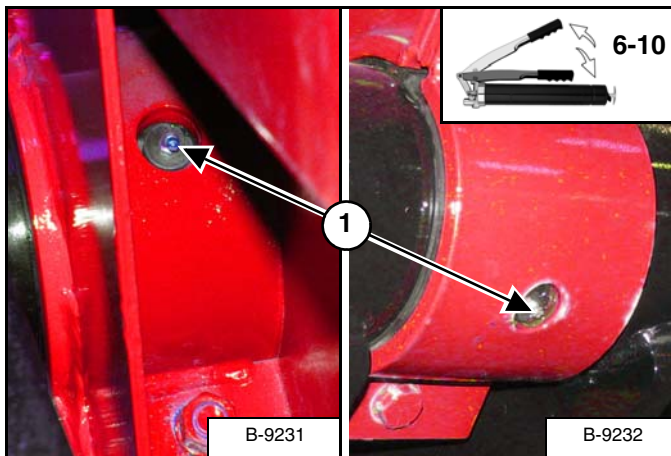

Apply six - ten pumps of grease to the rockshaft bearings (Item 1) [Figure 135] (all locations).

Lubricate the following grease locations **EVERY 50 HOURS:**

Figure 136

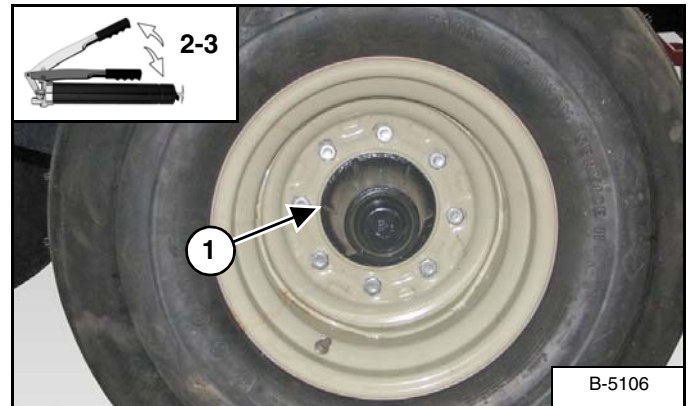

Apply two - three pumps of grease to the axle bearings (Item 1) [Figure 136] (all locations).

Repacking Wheel Bearings: Remove dust cap. Grease hub until new grease comes out outer end of hub.

Lubricate the following grease locations **EVERY 50 HOURS:**

Figure 137

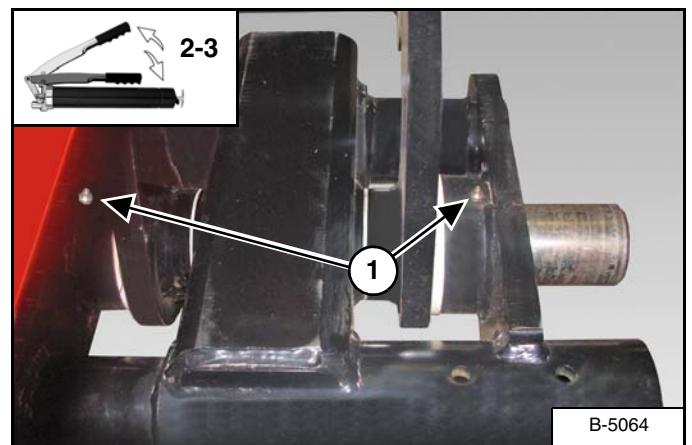

Apply two - three pumps of grease to the walking axles (Item 1) [Figure 137] (all locations).

Figure 138

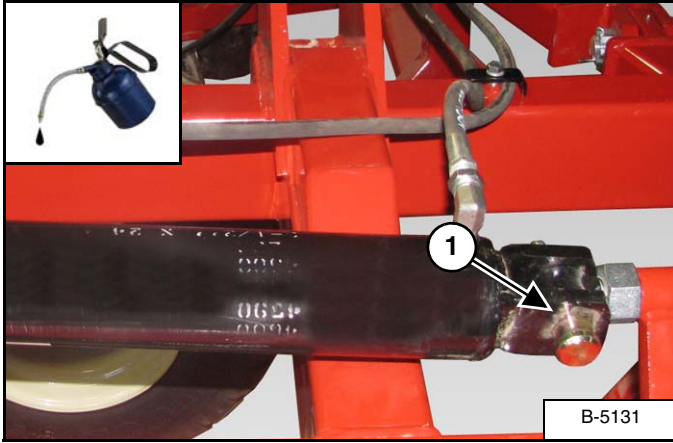

Apply oil to the rockshaft hydraulic cylinder pins (Item 1) [Figure 138] (all locations).

Lubricate the following grease locations **EVERY 100 HOURS:**

Figure 139

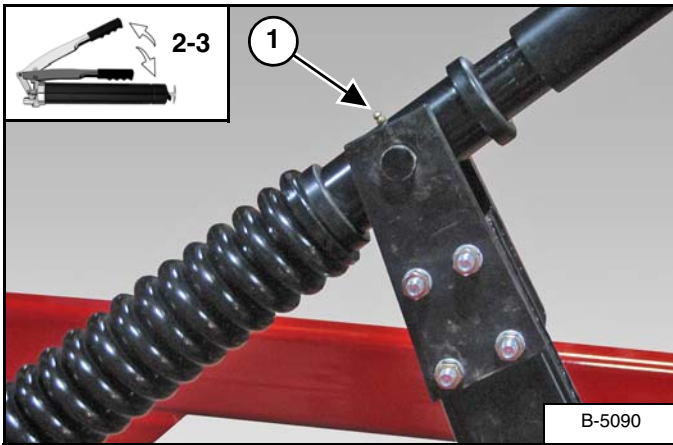

Apply two - three pumps of grease to the leveling crank (Item 1) [Figure 139].

Figure 140

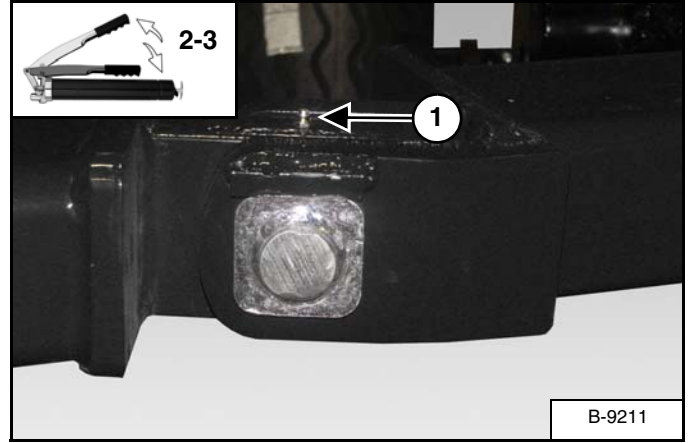

Apply two - three pumps of grease to the wing hinge points (Item 1) [Figure 140] (all locations top & bottom).

Lubricate the following grease locations **EVERY 500 HOURS:**

Figure 141

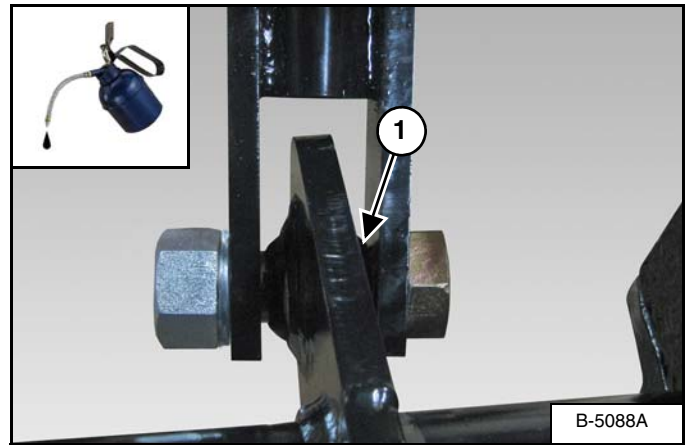

Apply oil to the leveling crank ball joint (Item 1) [Figure 141].

BEARING HANGERS

Inspection

Inspect and tighten all bearing hanger u-bolts after the first 10 hours of operation and daily thereafter.

Figure 142

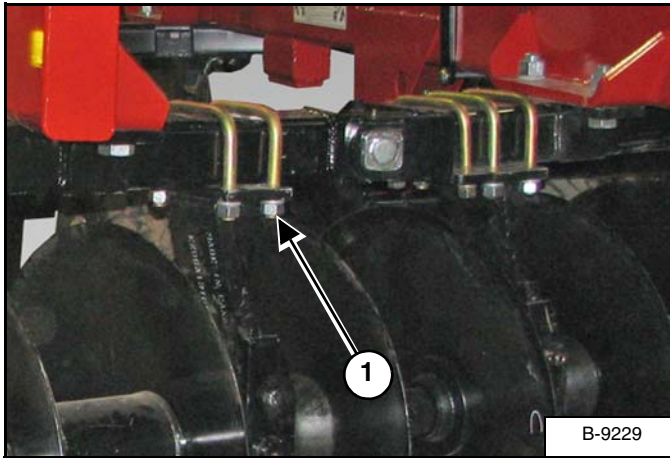

Tighten all bearing hanger u-bolts (Item 1) **[Figure 142]**.

Torque bearing hanger u-bolts to 430 ft. - lb. (583.0 N•m)

LEVELING CRANK

Inspection

Figure 143



Torque leveling crank bolt - 1-1/4 in. (31.7 mm) diameter - 840 ft. - lb. (1139 N•m)

! IMPORTANT

Leveling crank spring tension should not be changed from factory setting.

GANG SECTION

Gang Bolt Inspection



Always lower the disc to the ground when servicing or making adjustments. If disc must be serviced or adjusted in the raised position, place blocks under frame. Do not rely on hydraulic lock up valves as a safety device.

Figure 144

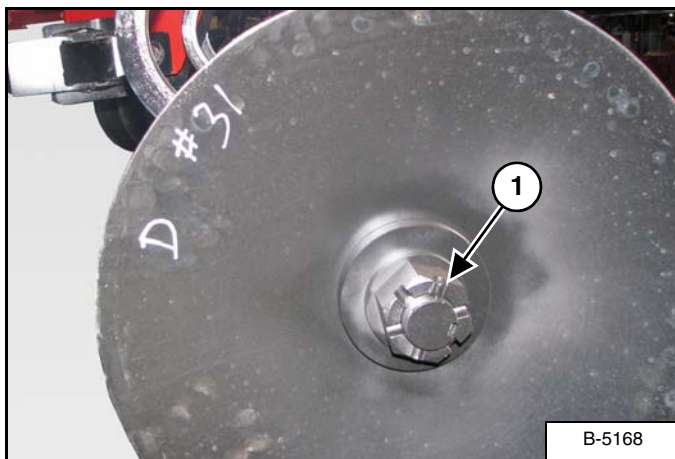

Visually inspect the gang bolt (Item 1) [Figure 144] daily.

Tightening Gang Bolt

Tighten 1-15/16" gang bolts to 3200 ft. - lb. (4339 N•m) torque.

NOTE: Visually inspect gang bolts daily.

Figure 145

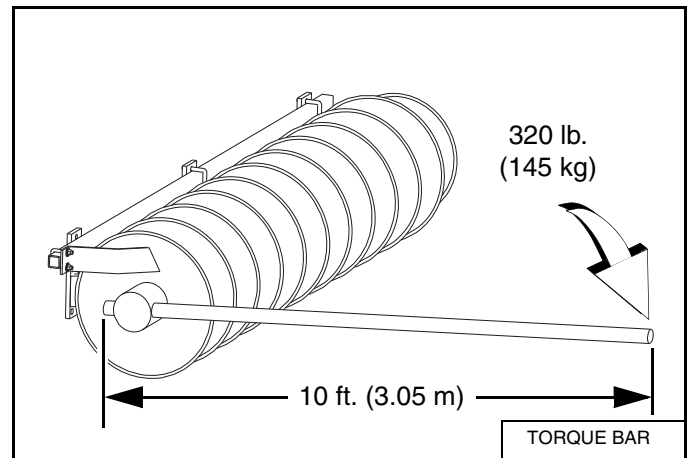

Install a 10 ft. bar of adequate size [Figure 145] and strength in socket wrench. Apply 320 lb. (145 kg) of force to end of bar and tighten gang bolt to 3200 ft. - lb. (4339 N•m).



After repairing a gang, the gang bolt should be re-tightened after 2 hours of operation.

NOTE: Severe damage will occur if gang bolts are loose.

AXLES

Wheel Bolts Torque



CHECK WHEEL BOLTS AFTER:

1. First 5 (five) hours of field operation.
2. First 25 (twenty-five) hours of field operation.
3. First 50 (fifty) hours of field operation.
4. Every 200 (two hundred) hours of operation.

REPEAT PROCEDURE IF A WHEEL IS REMOVED OR REINSTALLED

Tighten wheel bolts to 130 ft. - lb. (176.3 N•m) torque.

Tire / Wheel Replacement

Periodically check tires for cuts, bulges and damaged rims.



AVOID INJURY OR DEATH

Before you leave the operator's position:

- Always park on a flat level surface.
- Place all controls in **NEUTRAL**.
- Engage the park brake.
- Stop the engine and remove the key.
- Wait for all moving parts to stop.

Park the tractor / equipment on a flat level surface.

Place all controls in neutral, engage the park brake, stop the engine and wait for all moving parts to stop. Leave the operator's position.

Fully raise wings into transport position and secure with safety chain.



If wings are folded into transport position, always install a safety chain between each wing frame and main frame to prevent wings from falling.



AVOID INJURY OR DEATH

- Always chock tires before performing any maintenance or service.

Remove the eight wheel bolts and remove the tire / wheel.



Main frame wheels are attached with lock nuts. Remove lock nuts first, from the backside of each hub before removing the wheel bolts.

Place chock blocks behind and in front of the opposite tire to be removed.

Raise axle frame with jack until the tire / wheel is slightly off the ground.

NOTE: Place blocks / stands under the frame to secure the tandem disc when tire / wheel is raised off the ground.

Figure 146

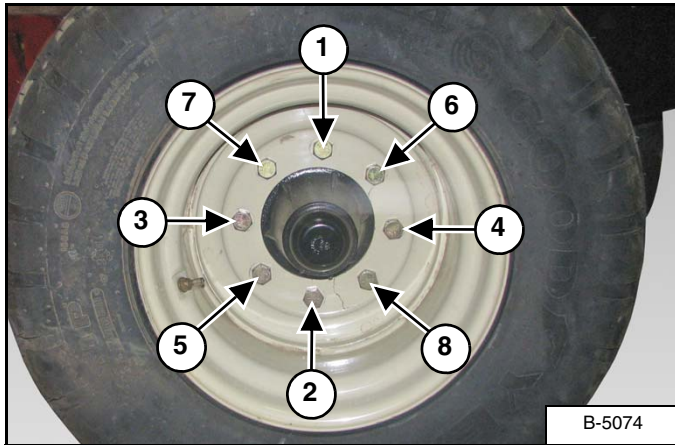

Install the new tire with the valve stem facing out.

Reinstall eight wheel bolts (Items 1 - 8) [Figure 146].

Tighten wheel bolts in a criss-cross pattern [Figure 146]. Tighten wheel bolts to 130 ft. - lb. (176.3 N•m) of torque.

Center Frame Tires

Install eight 9/16" NF nuts on the wheel bolt threads that extend past the back side of the hub. Tighten nuts against the hub.

Wheel Bearings

Inspect and re-pack the wheel bearings annually with a quality SAE multi purpose type grease.

Tire Pressure



When inflating tires, use a clip-on chuck and extension hose long enough to allow you to stand to one side and NOT in front of or over the tire assembly.

Center Frame Tires

Check tire pressure daily (See minimum - maximum tire pressure on the tire side wall).

Wing Frame Tires

Check tire pressure daily (See minimum - maximum tire pressure on the tire side wall).

CLEANING THE TANDEM DISC

Fully Clean the Tandem Disc **EVERY 50 HOURS**:

Keep the Tandem Disc free of any debris.

SERVICING T2-215 BEARINGS (IMPORTANT NOTES)

Figure 147

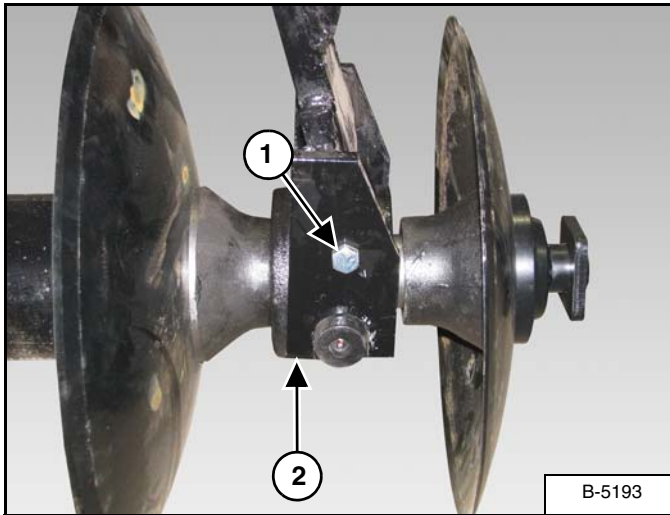

1. If T2-215 bearing must be dismantled, double set screws (Item 2) [Figure 147] must be removed from bottom of housing to remove seal cap.
2. When replacing grease seals in T2-215 bearing, ensure they are installed correctly. The I.D. of the outer shield is larger on one side than the other. Be sure the side with the larger I.D. of both seals are facing out. The rubber seal may be damaged if grease seal is not installed correctly.
3. When reinstalling bearing hanger on T2-215 bearing (if gangs are dismantled) do not over tighten the 5/8" x 10" bolts (Item 1) [Figure 147]. Snug / tighten the inner nut against bearing hanger. Tighten outer jam nut against inner nut to secure in position.

NOTE: The bolt may break during field operations if it is over tightened.

NOTE: Bolt (Item 1) [Figure 147] is 5/8" x 11" if equipped with wear guards.

WING LIFT CYLINDER

Removal And Installation



AVOID SERIOUS INJURY OR DEATH

If wing cylinders or wing lift hydraulic hoses are removed when wings are folded into transport position, always install a safety chain between each wing frame and main frame to prevent wings from falling.

Figure 148

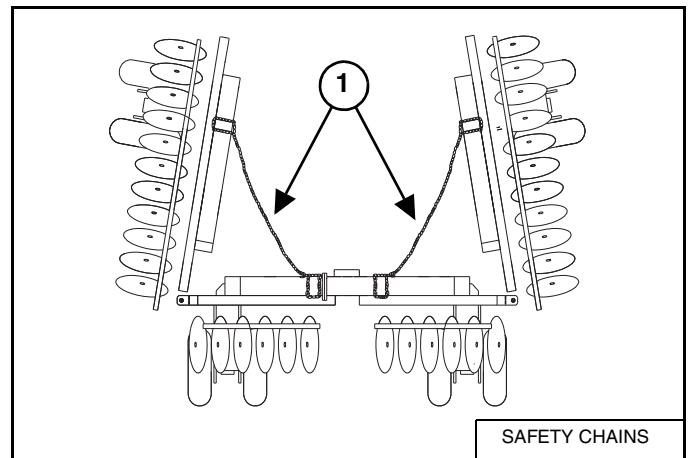

If wing lift cylinder hydraulic system must be serviced or repaired with wings in folded position, install safety chains (Item 1) [Figure 148], between each wing frame and main frame to prevent wings from falling.



Always install a chain on both wings even if only one cylinder is being worked on.

WALKING BEAMS

Installing The Walking Beams

NOTE: The following procedure shows the walking beam installation on the RH side of the main frame. The procedure is the same for the LH side of the main frame.

Figure 149

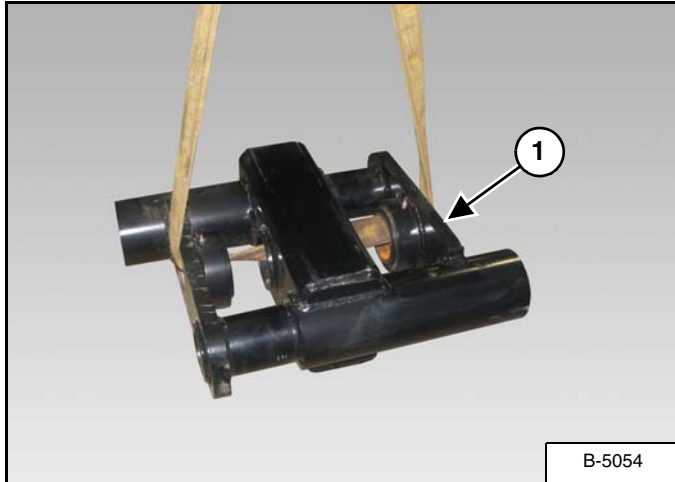

Locate the walking beams (Item 1) [Figure 149]. Install a strap through pivot holes of the walking beam.

Connect the straps to an approved lifting device.

Raise and move the walking beam to the assembly area.

Figure 150

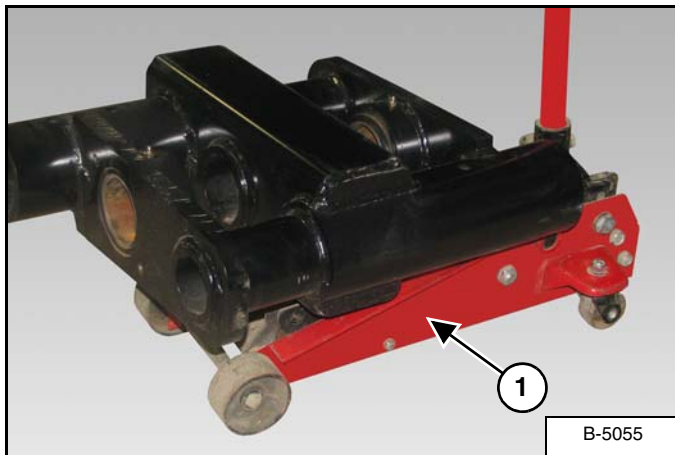

Lower the walking beam onto a floor jack (Item 1) [Figure 150].

NOTE: Adjust / center walking beam on the floor jack's lifting plate before removing strap.

Figure 151

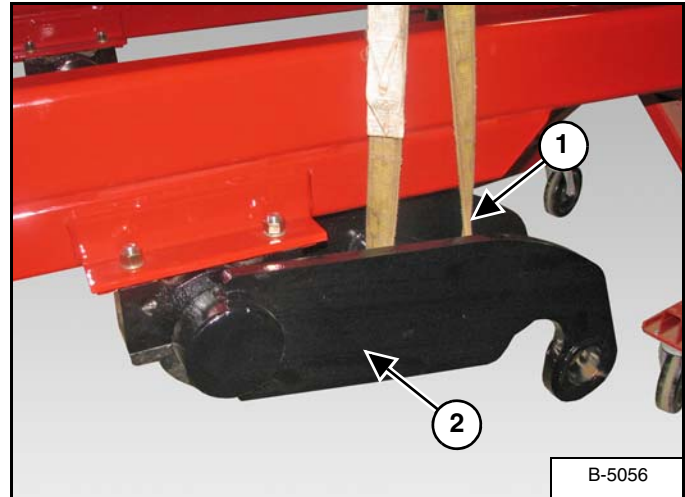

Install a strap (Item 1) around the LH side of the main frame rockshaft (Item 2) [Figure 151].

Raise the rockshaft until there is adequate space to allow the walking beam to be rolled into position below the rockshaft.

Figure 152

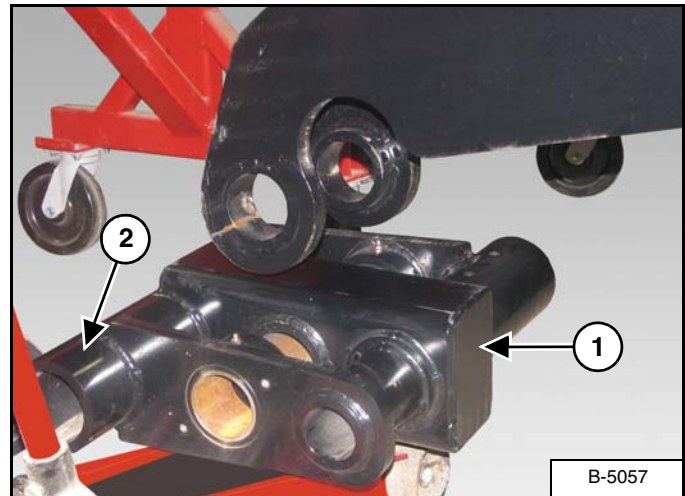

Move the walking beam into position under the rockshaft, with the rectangular plate (Item 1) [Figure 152] facing forward (front of disc).

NOTE: Walking beams must be positioned so the rear wheel spindle (Item 2) [Figure 152] is on the outside (both RH and LH side).

Figure 153

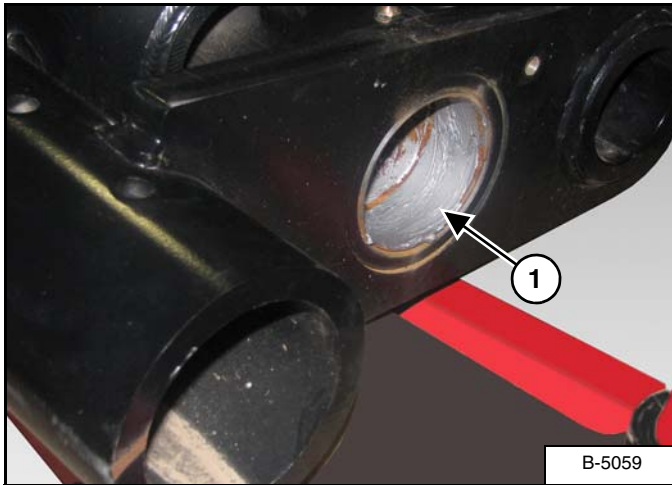

Apply an anti-seize compound (Item 1) [Figure 153] to the inside walking beam pivot holes (both sides).

Figure 154

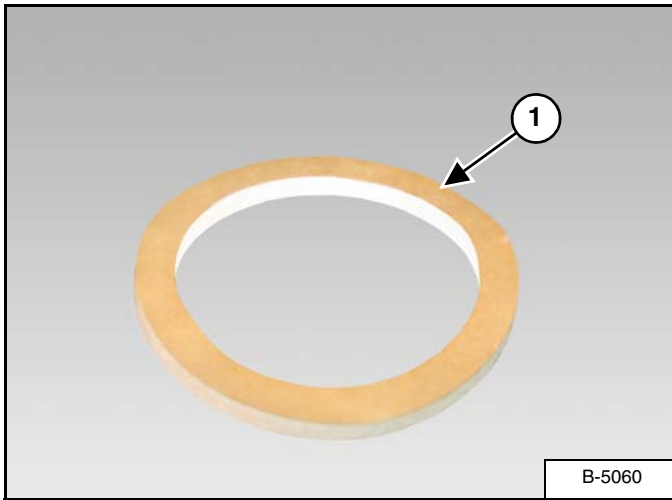

Locate two walking beam seals (Item 1) [Figure 154]. Remove backing from seals to expose adhesive surface.

Figure 155

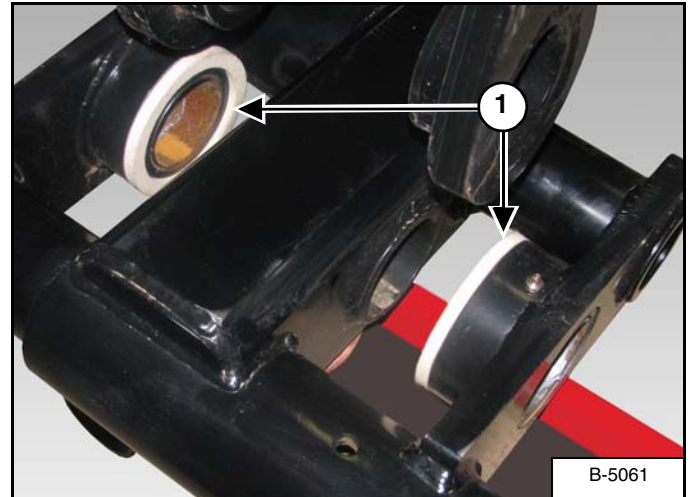

Install the walking beam seals (Item 1) [Figure 155] over the collars on the walking beam. Press firmly to secure the seals onto the walking beam.

Figure 156

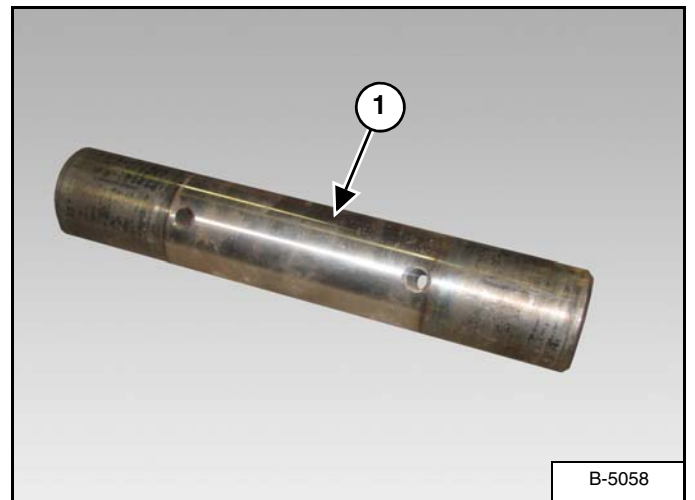

Locate one walking beam pivot pin (Item 1) [Figure 156].

Figure 157

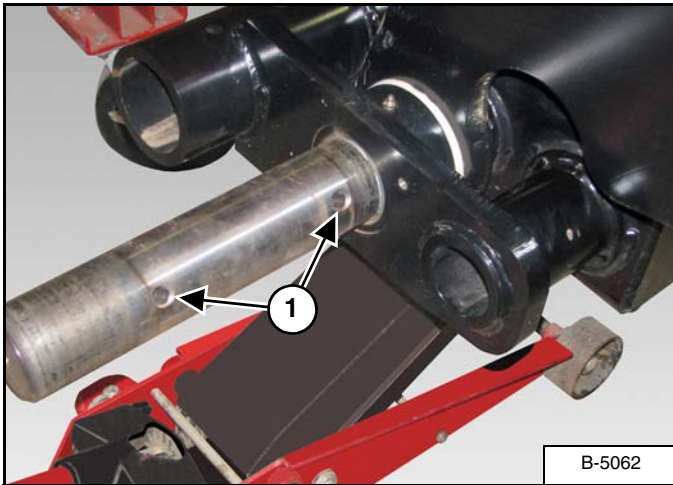

Raise floor jack until the walking beam pivot holes are aligned with the rockshaft legs [Figure 157].

NOTE: Raise floor jack and position walking beam carefully not to damage the seals.

Align the mounting holes (Item 1) [Figure 157] of the pivot pin with the mounting holes of the walking beam. Insert pivot pin until the end is flush with the inside of the first (outside) rockshaft leg.

Figure 158

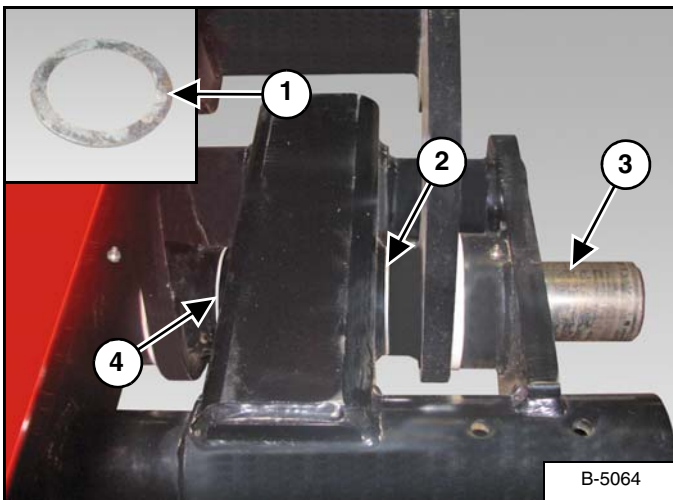

Locate shims (Item 1) [Figure 158].

Install shim / shims (Item 2) [Figure 158] at the outside rockshaft leg (as required).

NOTE: Walking beam pivot pin must be installed with minimal force. Install by hand or a light weight plastic or rubber mallet.

Insert pivot pin (Item 3) [Figure 158] through the shim / shims and center frame of the walking beam until the end of the pivot pin is flush with the inside of the center frame.

Install shim / shims (Item 4) [Figure 158] at the inside rockshaft leg (as required).

Insert pivot pin (Item 3) [Figure 158] through the shim / shims until the end of the pivot pin is flush with the inside of walking beam.

Figure 159

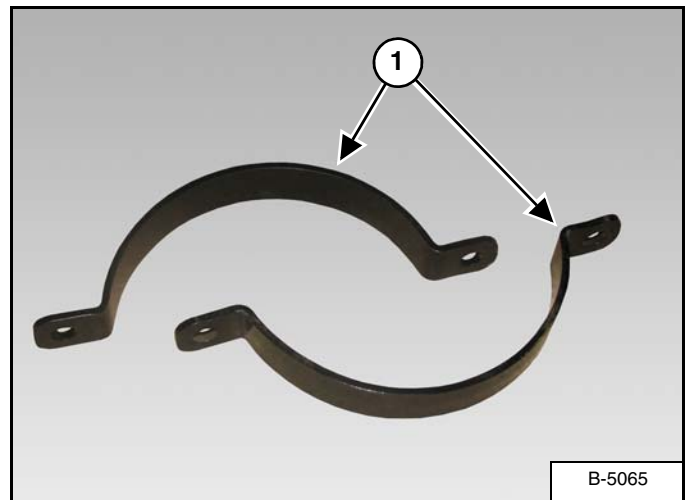

Locate four seal clamps (Item 1) [Figure 159], eight 3/8" x 3/4" bolts and eight 3/8" lock nuts.

Figure 160

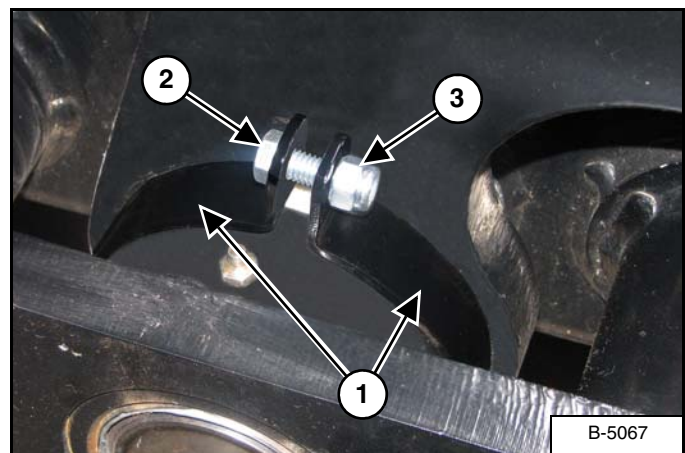

Position two seal clamps (Item 1) over the outside walking beam pivot, covering the seal. Install one 3/8" x 3/4" bolt (Item 2) through the two seal clamps (both ends) and install a 3/8" lock nut (Item 3) [Figure 160] on each bolt.

Push the seal clamps firmly against the rockshaft leg and tighten bolts and lock nuts.

Repeat for inside walking beam pivot / seal location.

Figure 161

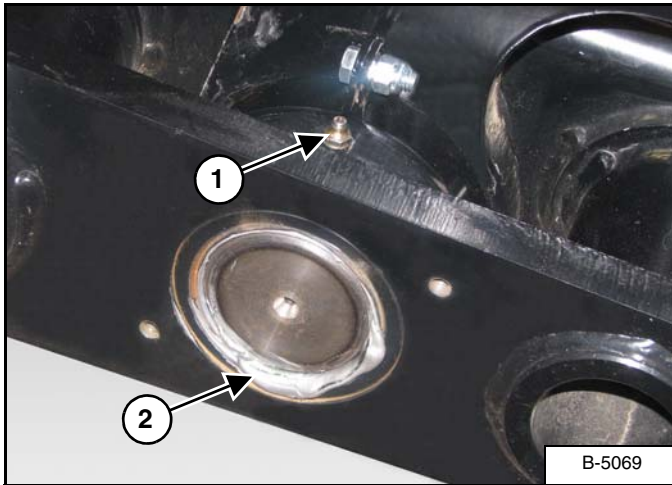

Apply a good quality lithium grease to inside and outside walking beam pivots grease fittings (Item 1) until extra grease (Item 2) [Figure 161] shows.

Figure 162

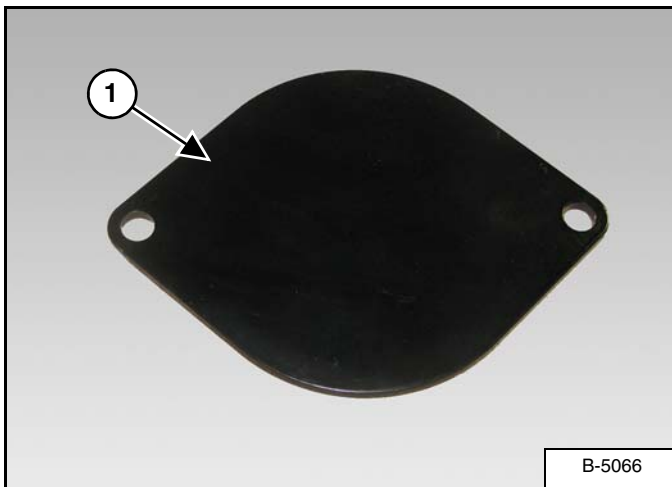

Locate two walking beam shaft covers (Item 1) [Figure 162] and four 3/8" x 3/4" bolts.

Figure 163

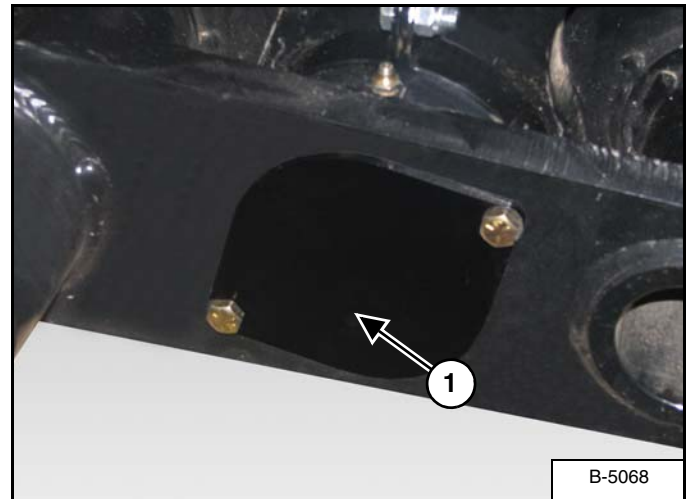

Install one walking beam shaft cover (Item 1) [Figure 163] on the inside and outside of the walking beam using four 3/8" x 3/4" bolts.

HITCH COMPRESSION SPRING

NOTE: The following images may not show your hitch compression spring exactly as it appears but the procedure is correct.

Figure 164

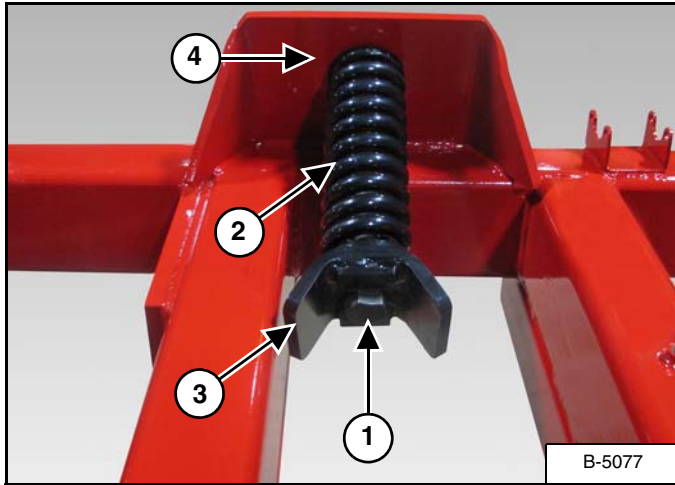

Install the 1" x 14" bolt (Item 1), through the compression spring (Item 2), and spring cushion plate (Item 3). Install the threaded bolt end through the mounting plate (Item 4) [Figure 164] on the main frame.

Figure 165

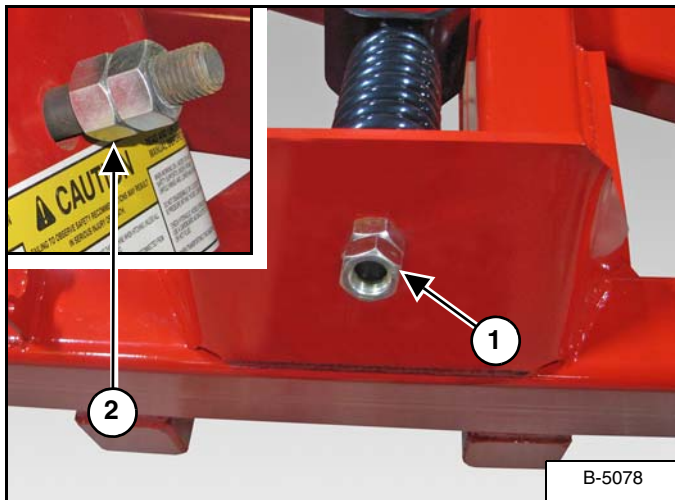

Install two 1" nuts (Item 1) [Figure 165] onto the 1" x 14" bolt.

Tighten the inside nut so the spring is compressed by 1 inch, then tighten outside nut against the inside securing the compression spring assembly to the main frame.

FRAME SPRING BUSHINGS

Removal And Installation

Removal

Using a pin / punch, gently tap the spring bushing until removed from the wing connecting link.

Installation

Figure 166

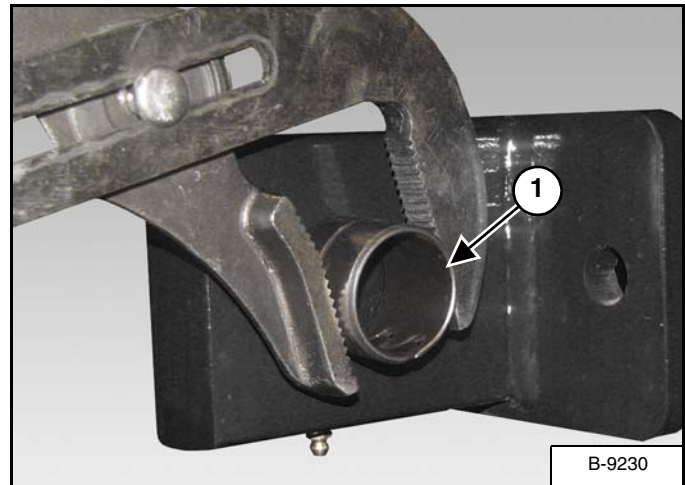

Using an adjustable pliers, align the spring bushing (Item 1) [Figure 166] with the wing connecting link, compress / squeeze the spring bushing and lightly tap into position with hammer.

NOTE: Spring bushing must be fully seated inside the wing connecting link. Spring bushing must be flush with the wing connecting link.

ROCKSHAFT SPRING BUSHINGS

Removal And Installation

Removal

Using a pin / punch, gently tap the spring bushing until removed from the wing rockshaft cylinder mount.

Installation

Figure 167

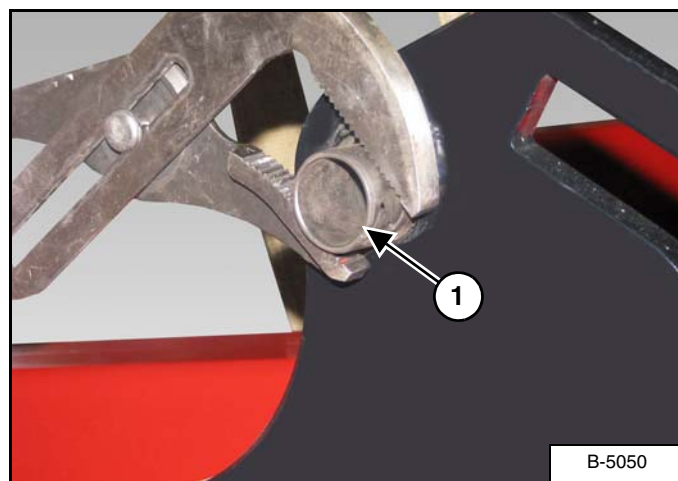

Using an adjustable pliers, align the spring bushing (Item 1) [Figure 167] with the wing rockshaft cylinder mount, compress / squeeze the spring bushing and lightly tap into position with hammer.

NOTE: Spring bushing must be fully seated inside the wing rockshaft cylinder mount. Spring bushing must be flush with the wing rockshaft cylinder mount.

Repeat procedure for LH wing rockshaft (if required).

SCRAPER BARS

Removal And Installation

Removal

Remove u-bolts from the scraper being replaced (as required).

Installation

Figure 168

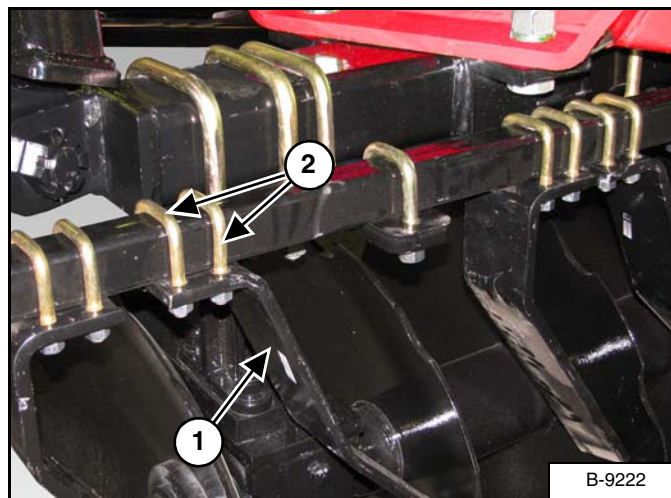

NOTE: Install inside scraper (Item 1) [Figure 168] first. Place the inside scraper approximately 1-1/2" from the inside end of the scraper bar.

Install two 1/2" x 2-1/2" u-bolts (Item 2) [Figure 168] over the scraper bar and down through the scraper. Install 1/2" lock washers and 1/2" nuts on the two u-bolts.

Tighten the two 1/2" x 2-1/2" u-bolts (Item 2) [Figure 168] and nuts to secure the scraper to the scraper bar.

Adjust scraper bar left / right until the first scraper is approximately 1/8" from the blade.

Tighten the first scraper bar mount u-bolts, securing the scraper bar in position while installing the remaining scrapers.

NOTE: Scraper bar mounts may need to be moved to allow adequate space for the remaining scrapers to be installed.

After all scrapers have been installed on the gang section and adjusted to 1/8" from the blades, tighten all scraper bar mount u-bolts and scraper bar u-bolts.

SAFETY SIGN (DECAL) INSTALLATION

Procedure



When replacing safety signs (decals), the temperature must be above 10° C (50° F).

- Remove all portions of the damaged safety sign (decal).
- Thoroughly clean the area with glass cleaner. Remove all adhesive residue.
- Allow the area to dry completely before installing the new safety sign (decal).
- Position the safety sign (decal) in the correct location. Remove a small portion of the backing paper on the safety sign (decal).
- Press on the safety sign (decal) where the backing paper has been removed.
- Slowly remove the remaining backing paper, pressing on the safety sign (decal) as the backing paper is removed.
- Using the backing paper, pressing firmly, move the backing paper over the entire safety sign (decal) area.

NOTE: Small air pockets can be pierced with a pin and smoothed out using the piece of the backing paper.

STORAGE AND RETURN TO SERVICE

Storage

Sometimes it may be necessary to store your Farm King Tandem Disc for an extended period of time. Below is a list of items to perform before storage.



AVOID SERIOUS INJURY OR DEATH

Always relieve the pressure in hydraulic system and close both hydraulic lockup valves when the disc is not being operated. Wings may unfold due to thermal expansion of hydraulic oil causing damage to disc, property or severe injury or death to person(s) nearby.



Do not leave cylinders under hydraulic pressure, especially if cylinders are activated during cool temperatures. The expansion of oil which takes place when machine is in a warmer environment may cause serious damage to cylinder, lines or hoses. Always release hydraulic pressure and close lockup valves before unhitching from tractor.



DO NOT permit children to play on or around the stored machine.

- Set planks under each wheel.
- Lower transport wheels to lift disc blades above the ground.
- Relieve pressure in all hydraulic cylinders.
- Disconnect hydraulic hoses from tractor and cap.
- Thoroughly clean the equipment.
- Lubricate the equipment.
- Inspect the hitch and all welds on the equipment for wear and damage.
- Check for loose hardware, missing guards, or damaged parts.
- Check for damaged or missing safety signs (decals). Replace if necessary.
- Replace worn or damaged parts.
- Touch up all paint nicks and scratches to prevent rusting.
- Store the tandem disc in a clean, dry, sheltered area.
- Place the equipment flat on the ground.
- Storing Outdoors - Cover hydraulic cylinders and hoses with weatherproof material and coat all exposed cylinder shafts with grease.

Return To Service

After the Farm King tandem disc has been in storage, it is necessary to follow a list of items to return the equipment to service.



Do not attempt to lift disc out of frozen ground by lowering transport wheels causing serious damage to disc components.

- Lubricate the equipment.
- Clean and inspect tandem disc.
- Tighten loose hardware and replace damaged parts.
- Inspect and repack wheel bearings with a SAE multi purpose type grease.
- Check that tires are properly inflated.
- Connect to a tractor and operate equipment, verify all functions operate correctly.
- Check for leaks. Repair as needed.
- Review the Operator’s Manual.

Farm King



PARTS IDENTIFICATION

GENERAL INFORMATION 129

 Hitch And Leveling Crank Assembly - Super Narrow, Narrow Frame And Wide Frame 130

 Hydraulic Hose Bracket Assembly 132

 Leveling Crank Assembly - Super Narrow, Narrow Frame And Wide Frame 133

 Hub And Spindle Assembly - Super Narrow Main Frame 134

 Hub And Spindle Assembly - Narrow Main Frame 135

 Hub And Spindle Assembly - Wide Main Frame 136

 Hub And Spindle Assembly - Wing Frame 137

 Tire Assembly - Super Narrow 138

 Tire Assembly - Narrow 140

 Tire Assembly - Wide 142

 Hydraulic Components - Super Narrow Frame 144

 Hydraulic Plumbing - Super Narrow Frame 146

 Hydraulic Components - Narrow Frame 148

 Hydraulic Plumbing - Narrow Frame 150

 Hydraulic Components - Wide Frame 152

 Hydraulic Plumbing - Wide Frame 154

 Wing Lift Cylinder - 4 In. x 36 In. (102 x 914 mm) 156

 Wing Lift Cylinder Seal Kit - 4 In. x 36 In. (102 x 914 mm) 156

 Wing Lift Cylinder - 5 In. x 36 In. (127 x 914 mm) 157

 Wing Lift Cylinder Seal Kit - 5 In. x 36 In. (127 x 914 mm) 158

 Main Rockshaft Cylinder - 4 In. x 24 In. (101.6 x 610 mm) 160

 Main Rockshaft Cylinder Seal Kit 160

 LH Wing Rockshaft Cylinder - 3-1/2 In. x 24 In. (88.9 x 610 mm) 161

 LH Rockshaft Cylinder Seal Kit 161

 RH Wing Rockshaft Cylinder - 3 In. x 24 In. (76.2 x 610 mm) 162

 RH Rockshaft Cylinder Seal Kit 162

 Walking Beams Assembly 163

 Rockshaft Assembly - Main Frame 164

 Wing Frame - Super Narrow 166

 Wing Frame - Narrow 167

 Wing Frame - Wide 168

 Gang Socket 169

 Wing Gang Beams 10.5 In. Spacing 170

 Wing Gang Beams 12 In. Spacing 172

 Wing Beam 26" x 0.313" Blades - 10.5" Spacing 174

 Wing Beam 26 In. x 0.375 In. Blades - 10.5 In. Spacing 175

 Wing Beam 28 In. x 0.375 In. Blades - 10.5 In. Spacing & 12 In. Spacing 175

 Wing Beam 30 In. x 0.375 In. Blades - 12 In. Spacing 175

 Rockshaft Assembly - Wing Frame 176

 Warning Light Assembly 177

 Scraper Assembly (10.5 In. Spacing) 178

 Gang Assembly, T2-215 Bearings, 10.5 In. Spacing, 26 In. Blades 180

 Gang Assembly, T2-215 Interlocking Bearings, 10.5 In. Spacing, 28 In. Blades, Keyed 182

Gang Assembly, T2-215 Interlocking Bearings, 12 In. Spacing, 28 In. Blades, Keyed	184
Gang Assembly, T2-215 Interlocking Bearings, 12 In. Spacing, 30 In. Blades, Keyed	186
Stone Flex Hanger Assembly	188
T2-215 Bearing Assembly	189
T2-215 Bearing Assembly, 7-3/16 In. Sleeve	190
T2-215 Bearing Assembly, 9 In. Sleeve	191

GENERAL INFORMATION

The parts identification section lists descriptions, part numbers and quantities for the 8700 Tandem Disc. Contact your Farm King dealer for additional 8700 Tandem Disc parts information.



Hitch And Leveling Crank Assembly - Super Narrow, Narrow Frame And Wide Frame

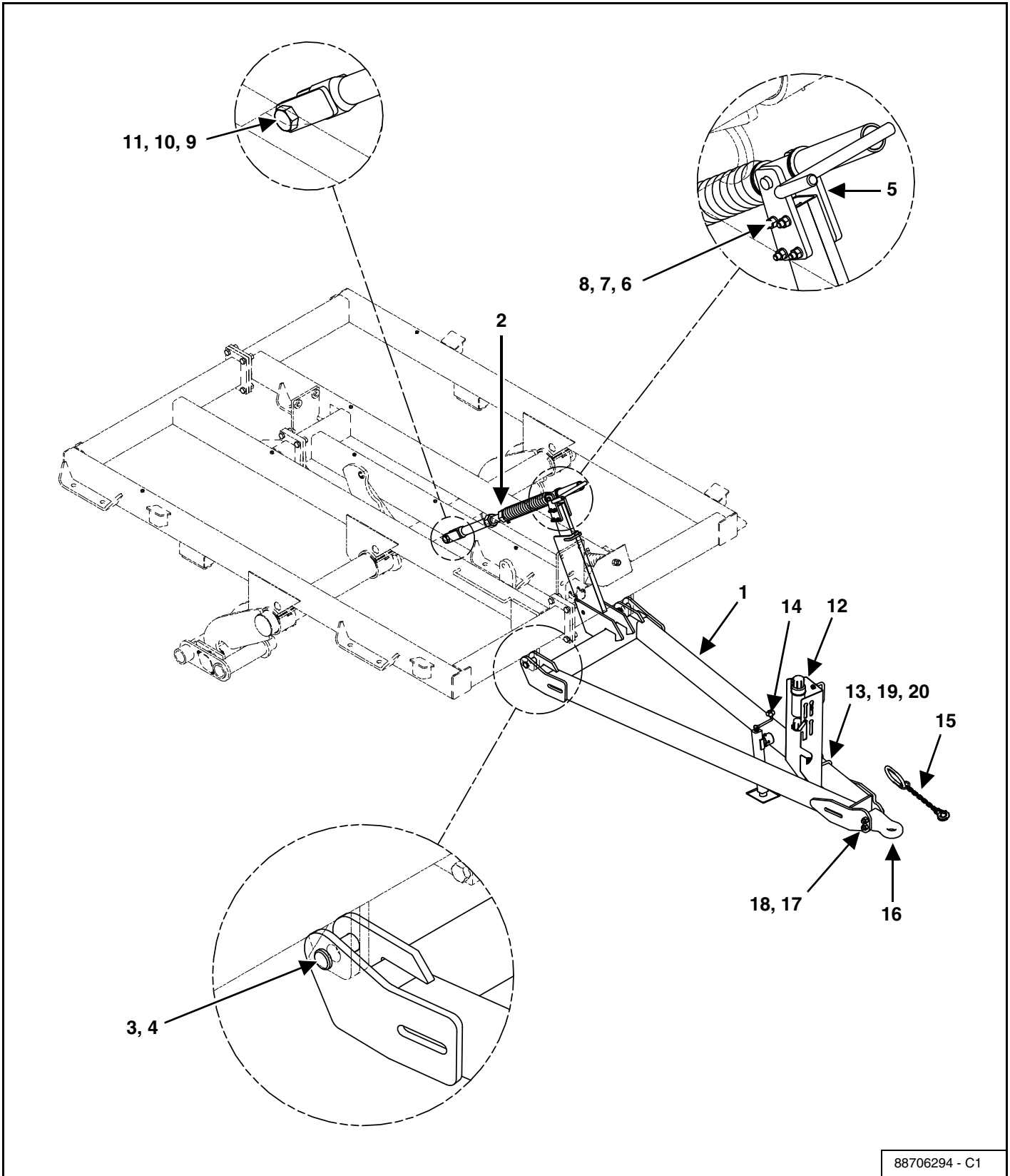

ITEM	PART NUMBER	DESCRIPTION	QTY
1	88715120	HITCH-W.A. TANDEM DISC	1
2	88706219	LEVELING CRANK ASSEMBLY, TD SN & N	1
	88713236	LEVELING CRANK ASSEMBLY, TD WIDE	1
3	EZDHA9605	HITCH PIN, 1-1/2" W.A	2
4	EZDH12517	HITCH LOCK PIN,	2
5	EZDH5146	PLATE, LEVELING LUG HITCH	1
6	EZB050050	BOLT, HEX CAP 1/2" NC x 5" GR 5 ZNCR	4
7	EZBW050L	LOCK WASHER, 1/2" x 7/8" x 1/8" ZNCR	8
8	EZBN050	NUT, HEX 1/2" NC ZNCR	8
9	EZDR5215	BOLT, HEX 1-1/4" NC x 4-3/4"	1
10	EZBW125L	LOCK WASHER, 1-1/4" x 1" x 5/16" ZNCR	1
11	EZBN125	NUT, HEX 1-1/4 NC GR 2 ZNCR	1
12	88708500	HYD HOSE, BRACKET	1
13	EZPL83773	U-BOLT, 5/8" x 5-1/2" x 6-1/16" x 1-1/2" GR 5 PL	2
14	88715180	JACK ASSY - W / WELD COLLAR	1
15	EZD13091	SAFETY CHAIN, 30K LB RATING	1
16	EZA76128	CATEGORY 4 PINTLE HITCH	1
17	EZC60074	BOLT, 1" x 7" NC HEX GR 8 P	2
18	EZBN100SL	LOCK NUT, 1"-8 TOP LOCK GRC PL	2
19	EZBW062L	LOCK WASHER, 5/8" P 86505602	4
20	EZBN062	NUT, 5/8" GR 5 P 86505599	4

Hydraulic Hose Bracket Assembly

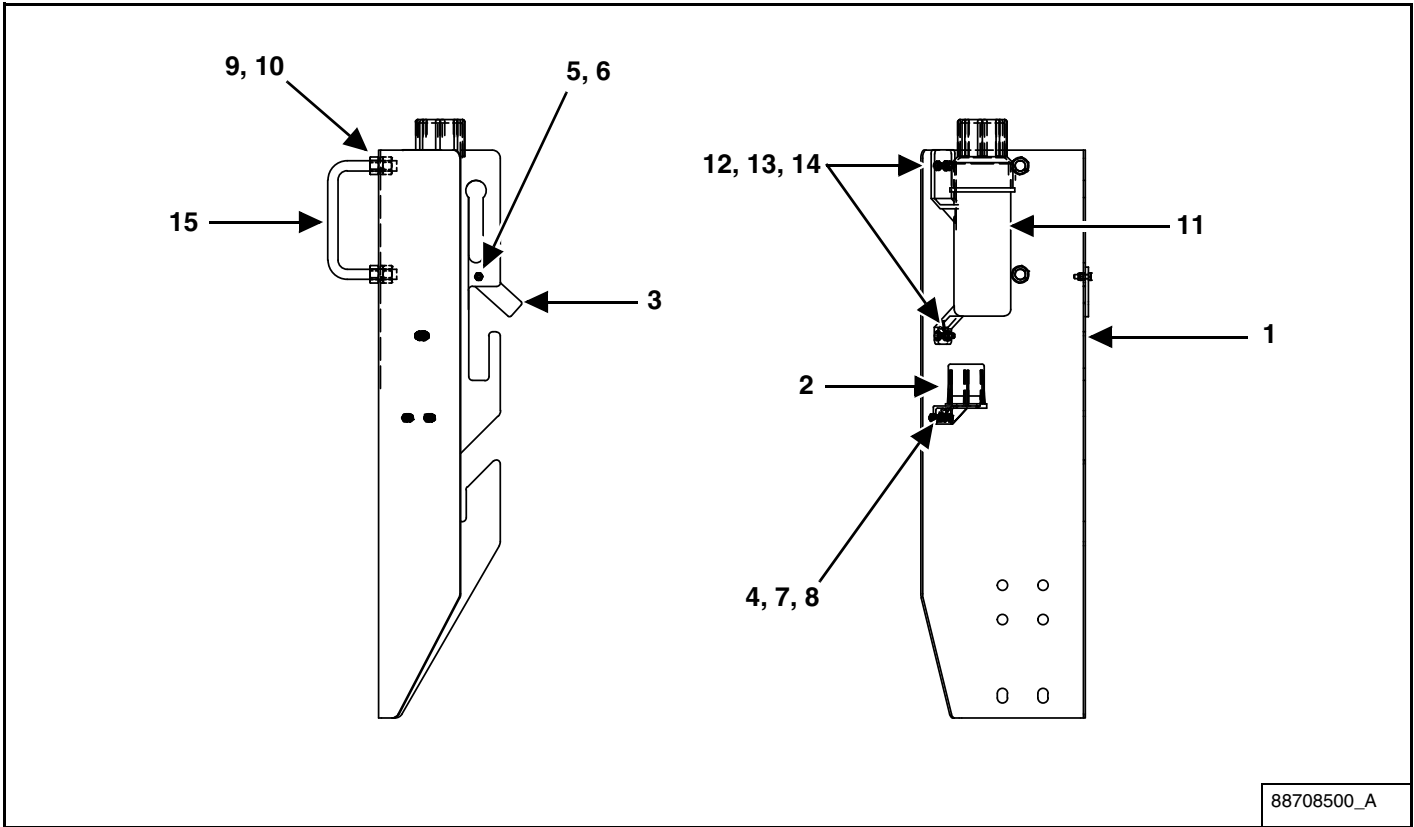

ITEM	PART NUMBER	DESCRIPTION	QTY
1	88704487	HYDRAULIC HOSE SUPPORT BRACKET	1
2	88704488	ELECTRICAL PLUG STORAGE HOLDER	1
3	88704489	CONNECTOR STOP TAB	1
4	EZB025006	BOLT, 1/4" NC x 5/8" HEX	2
5	EZB025009	BOLT, 1/4" NC x 7/8" HEX	1
6	EZBN025L	LOCK NUT, 1/4" NC HEX NYL	1
7	7770	NUT, 1/4" GR 5 P 86505597	2
8	80682	LOCK WASHER, 1/4" P 86505602	2
9	EZBN062	NUT, 5/8" NC HEX GR 5 ZNC	4
10	EZBW062L	LOCK WASHER, 5/8" x 9/16" x 5/32" ZNCR	2
11	909277	MANUAL HOLDER	1
12	EZB031010	BOLT, 5/8" NC x 2" HEX GR5 ZNCR	2
13	EZBW031L	LOCK WASHER, 5/16" x 19/32" x 3/32"	2
14	EZBN031	NUT, 5/16" NC HEX	2
15	EZC60525	U-BOLT, 0.625" x 3.6" x 6" x 1.5" GR 5 PL	1

Leveling Crank Assembly - Super Narrow, Narrow Frame And Wide Frame

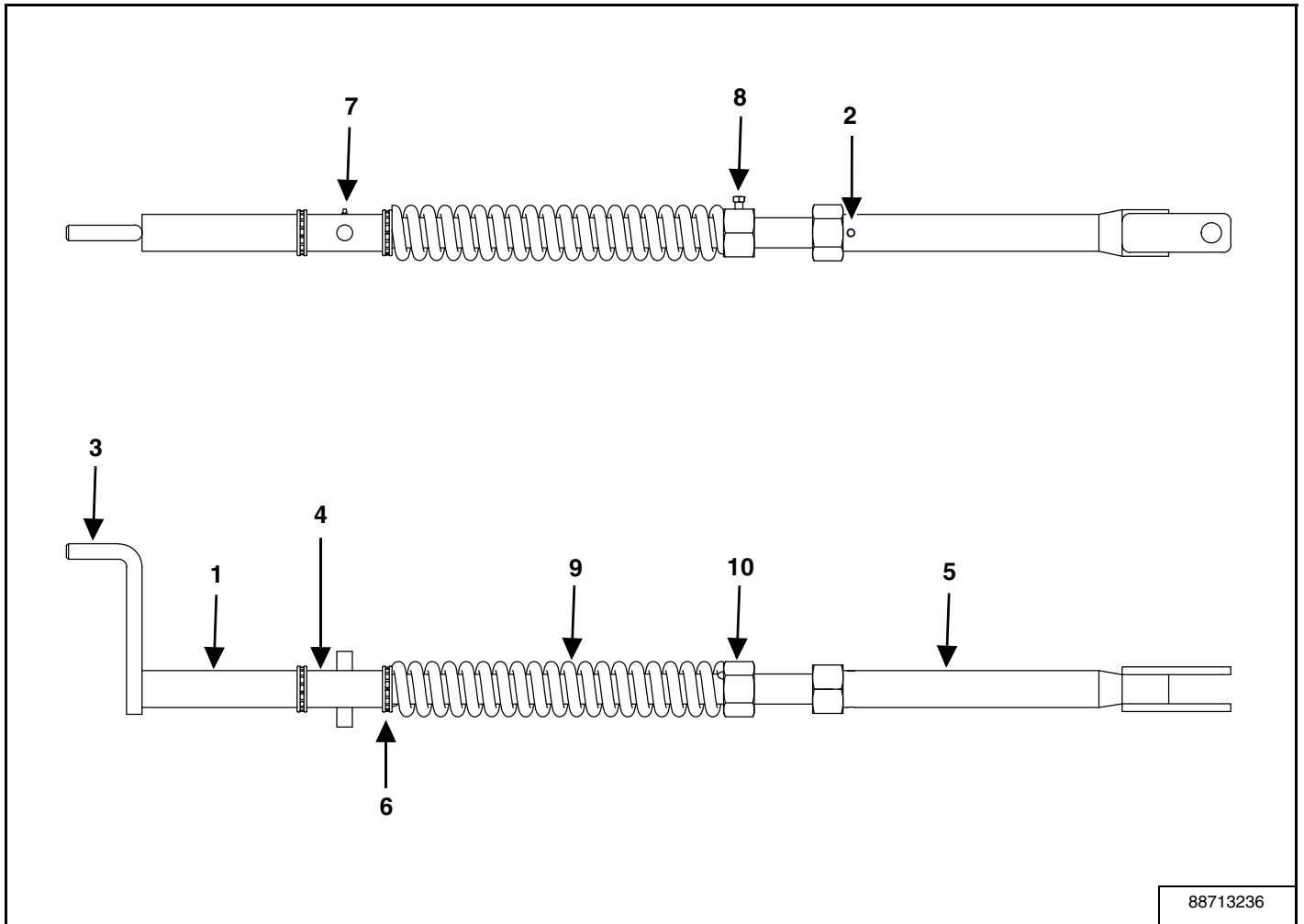

88713236

ITEM	PART NUMBER	DESCRIPTION	QTY
1	88706295	TUBE, TOP SPACER CRANK	1
2	88706044	PIN, LOCK, CRANK	1
3	EZDCA9970	LEVELING CRANK-W.A.	1
4	EZDCA5184	TRUNION PIVOT - W.A. LEVEL CRANK	1
5	88706297	LEVELING PIPE-W.A.	1
6	EZDC15	BEARING, THRUST, TIMKEN T199	2
7	EZ10GN1	FITTING, ZERK, 1/4" UNF ST	1
8	EZB050010S	SET SCREW, SQ HD 1/2" NC x 1"	1
9	EZDC9618	LEVELING CRANK SPRING, 1000	1
	EZDC9619	LEVELING CRANK SPRING, 2000	1
10	EZDH5	NUT, 2" HEX NC GR 2 W / SET	1

Hub And Spindle Assembly - Super Narrow Main Frame

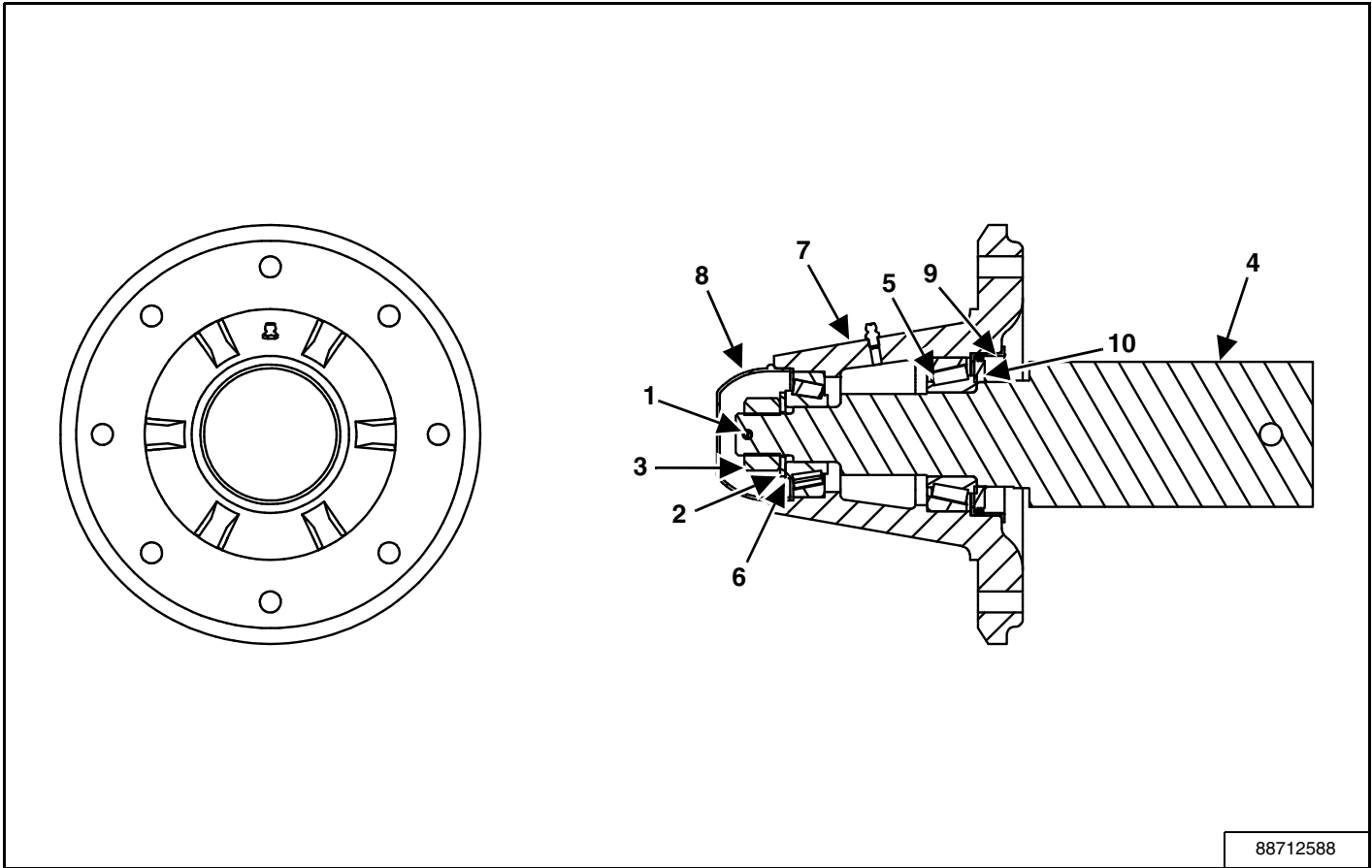

88712588

ITEM	PART NUMBER	DESCRIPTION	QTY
1	EZBP18125	PIN, COTTER, 3/16" x 1-1/4"	1
2	EZBW20010612F	FLAT WASHER, 1-1/16" x 2" x 1/8"	1
3	EZDR110	NUT, HEX SLOT, 1-14" NS GR 5 ZNCR	1
4	88712587	SPINDLE, 13-3/4" x 3-1/2" OD (812)	1
5	EZDR9684	BEARING CONE, 3780	1
6	EZDR9685	BEARING CONE, 2790	1
7	EZDRA9679	8 BOLT HUB ASSEMBLY W / CUPS	1
8	EZDR9681	HUB CAP	1
9	DR13200	8 BOLT HUB SEAL CUP	1
10	DR13201	8 BOLT HUB SEAL, (812)	1

Hub And Spindle Assembly - Narrow Main Frame

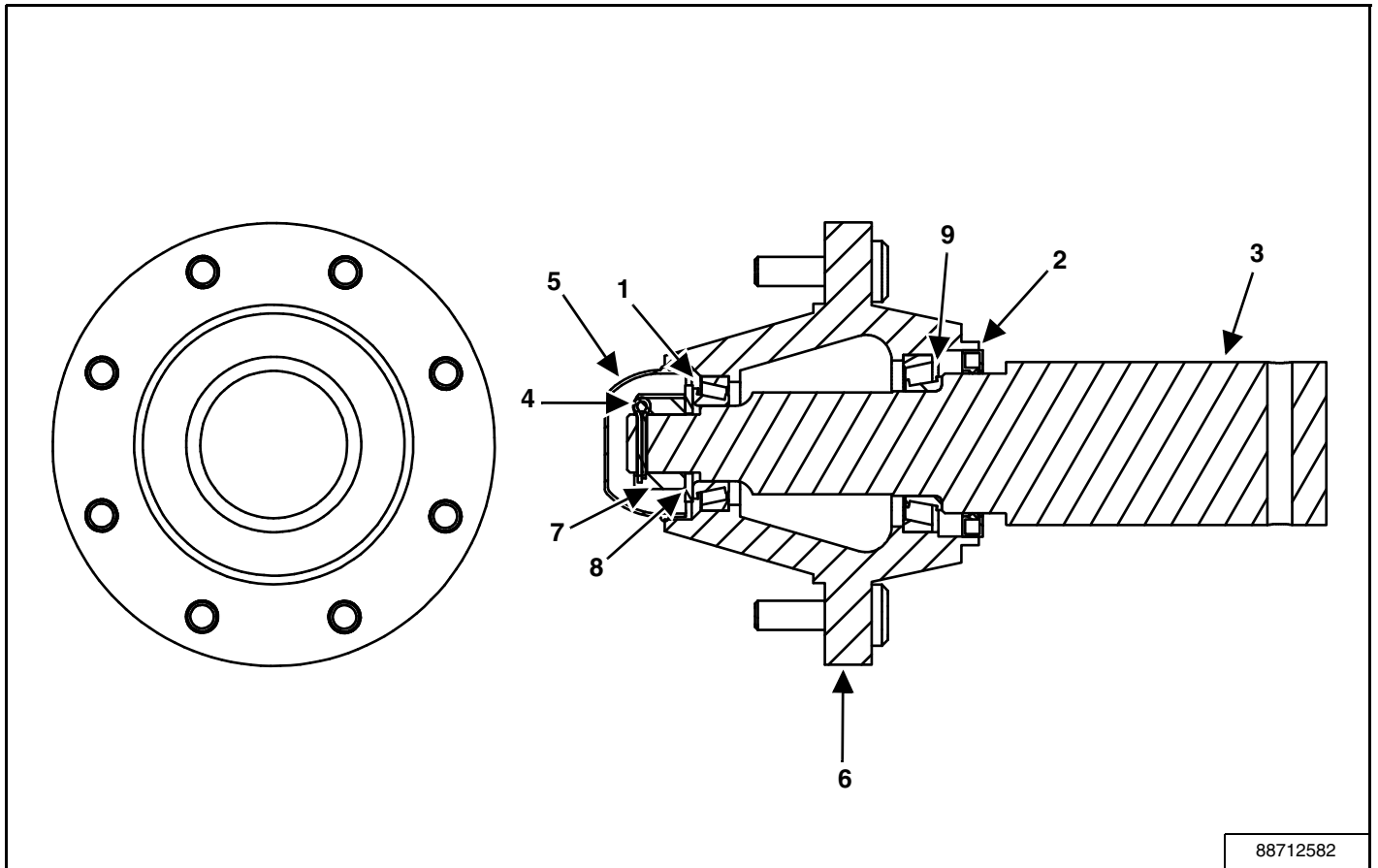

88712582

ITEM	PART NUMBER	DESCRIPTION	QTY
1	88713013	BEARING CONE	1
2	EZA77040	GREASE SEAL, SE-42	1
3	88712594	SPINDLE, 15" x 3-1/2" OD (817)	1
4	EZBP18125	COTTER PIN, 3/16" x 1-1/4"	1
5	EZDR9681	HUB CAP	1
6	88713012	8 BOLT HUB, ASSEMBLY W / CUPS	1
7	EZDR13126	NUT, 1-1/4" UNF HEX SLOT, P 86528691	1
8	EZBW25012815F	WASHER, 2-1/2" OD x 1-9/32" ID	1
9	88713014	BEARING CONE	1

Hub And Spindle Assembly - Wide Main Frame

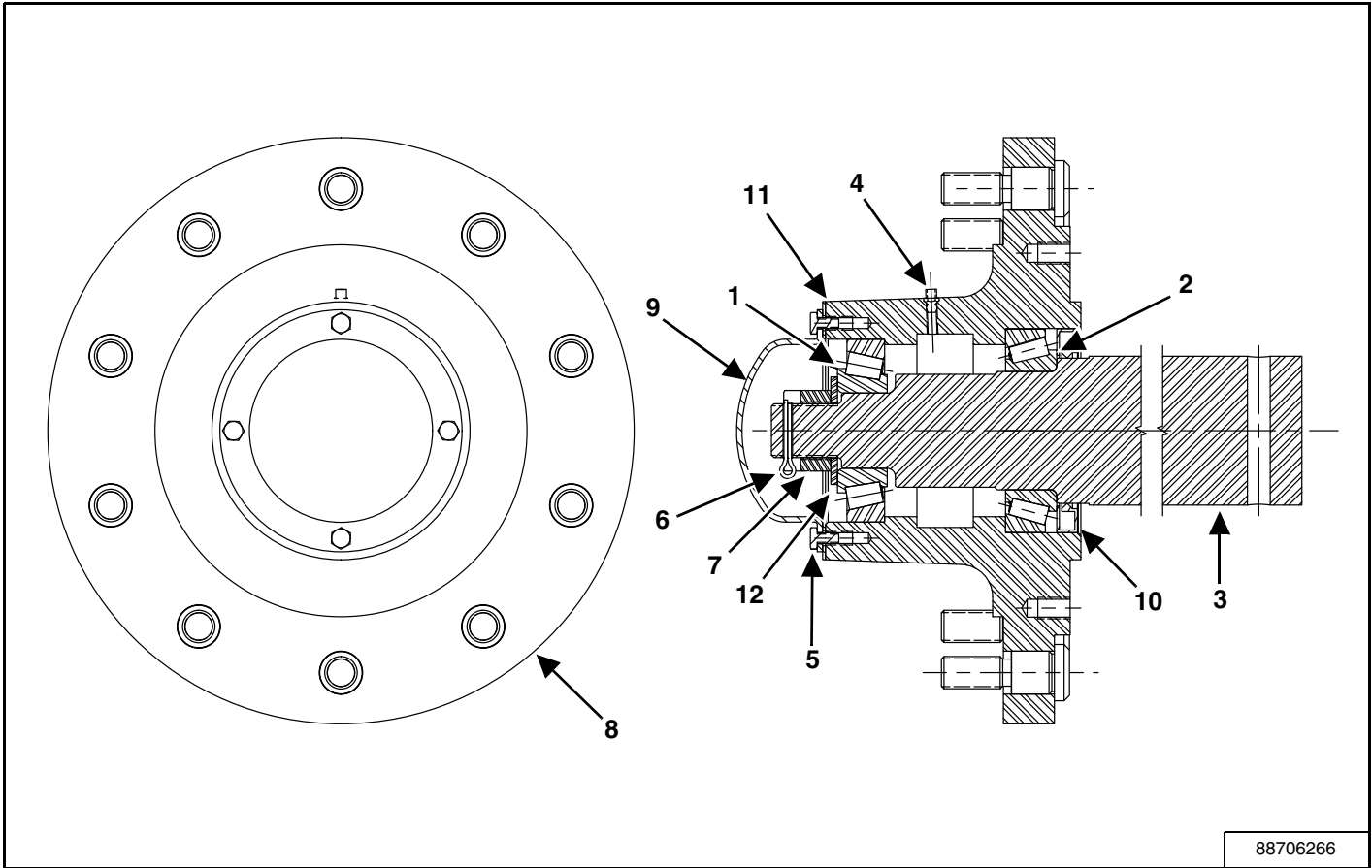

ITEM	PART NUMBER	DESCRIPTION	QTY
1	EZA70540	OUTER CONE BEARING	1
2	EZA70538	BEARING, INNER CUP #33462	1
3	88706265	SPINDLE, 812 18-1/2 H1010	1
4	EZ10GN1	GREASE ZERK, 1/4" UNF ST	1
5	EZB025050	BOLT, 1/4" NC x 1/2" HEX	4
6	EZBP18125	COTTER PIN, 3/16" x 1-1/4"	1
7	EZDR13126	NUT, 1-1/4" UNF HEX SLOT, PL 86528691	1
8	EZA75886	10 BOLT HUB ASSEMBLY W / CUPS	1
9	EZA70542	DUST CAP	1
10	EZA70536	GREASE SEAL	1
11	EZA70541	DUST CAP SEAL	1
12	EZBW25012815F	WASHER, 1/2" OD x 1-9/32" ID	1

Hub And Spindle Assembly - Wing Frame

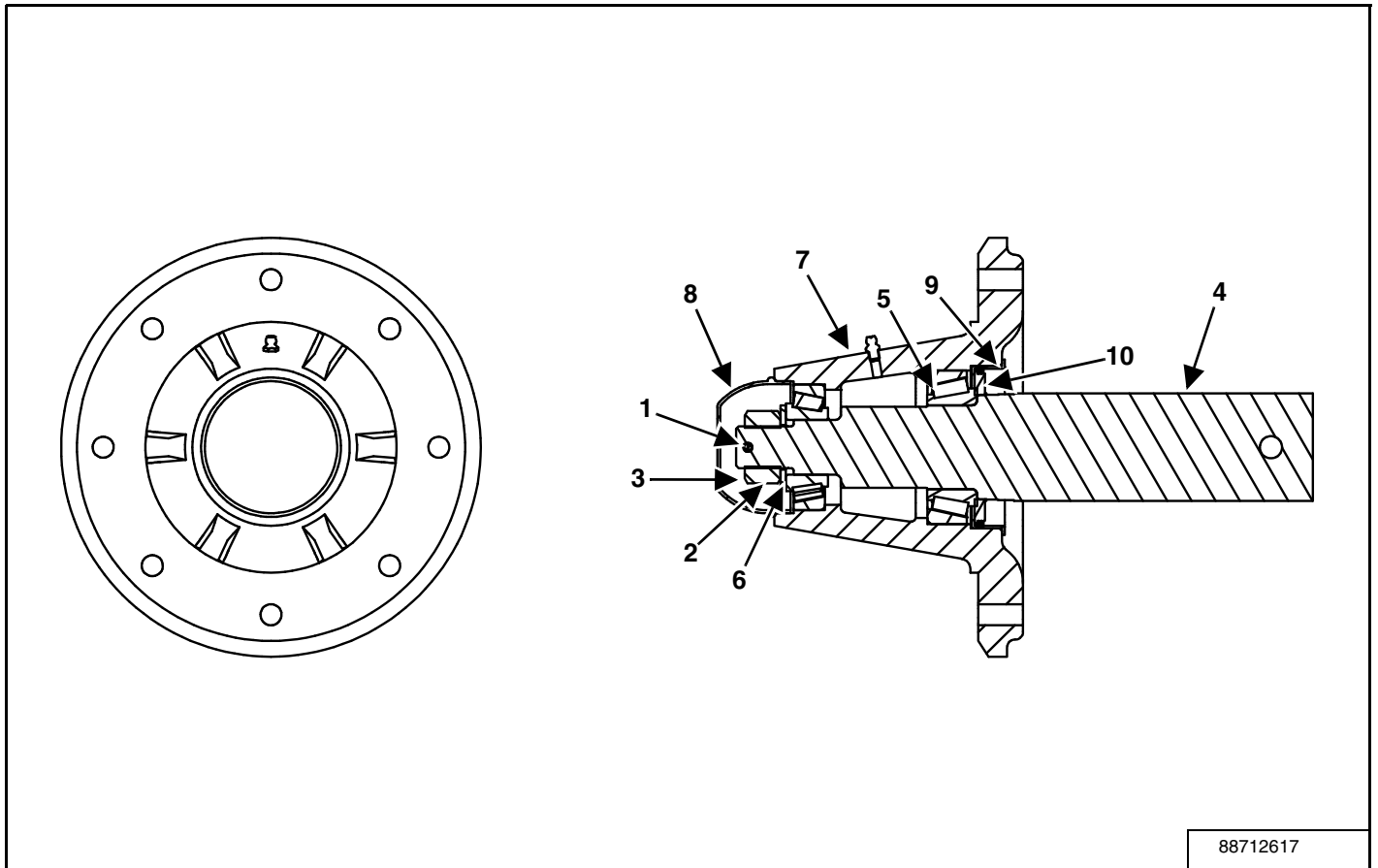

88712617

ITEM	PART NUMBER	DESCRIPTION	QTY
1	EZBP18125	COTTER PIN, 3/16" x 1-1/4"	1
2	EZBW20010612F	FLAT WASHER, 1-1/16" x 2" x 1/8"	1
3	EZDR110	NUT, 1" - 14 HEX SLOTGR 5 ZNCR	1
4	EZDR13004	SPINDLE, 13-3/4" 812	1
5	EZDR9684	BEARING CONE, 3780	4
6	EZDR9685	BEARING CONE, 2790	1
7	EZDRA9679	8 BOLT HUB ASSEMBLY W / CUPS	1
8	EZDR9681	HUB CAP	1
9	DR13200	8 BOLT HUB SEAL CUP	1
10	DR13201	8 BOLT HUB SEAL, (812)	1

Tire Assembly - Super Narrow

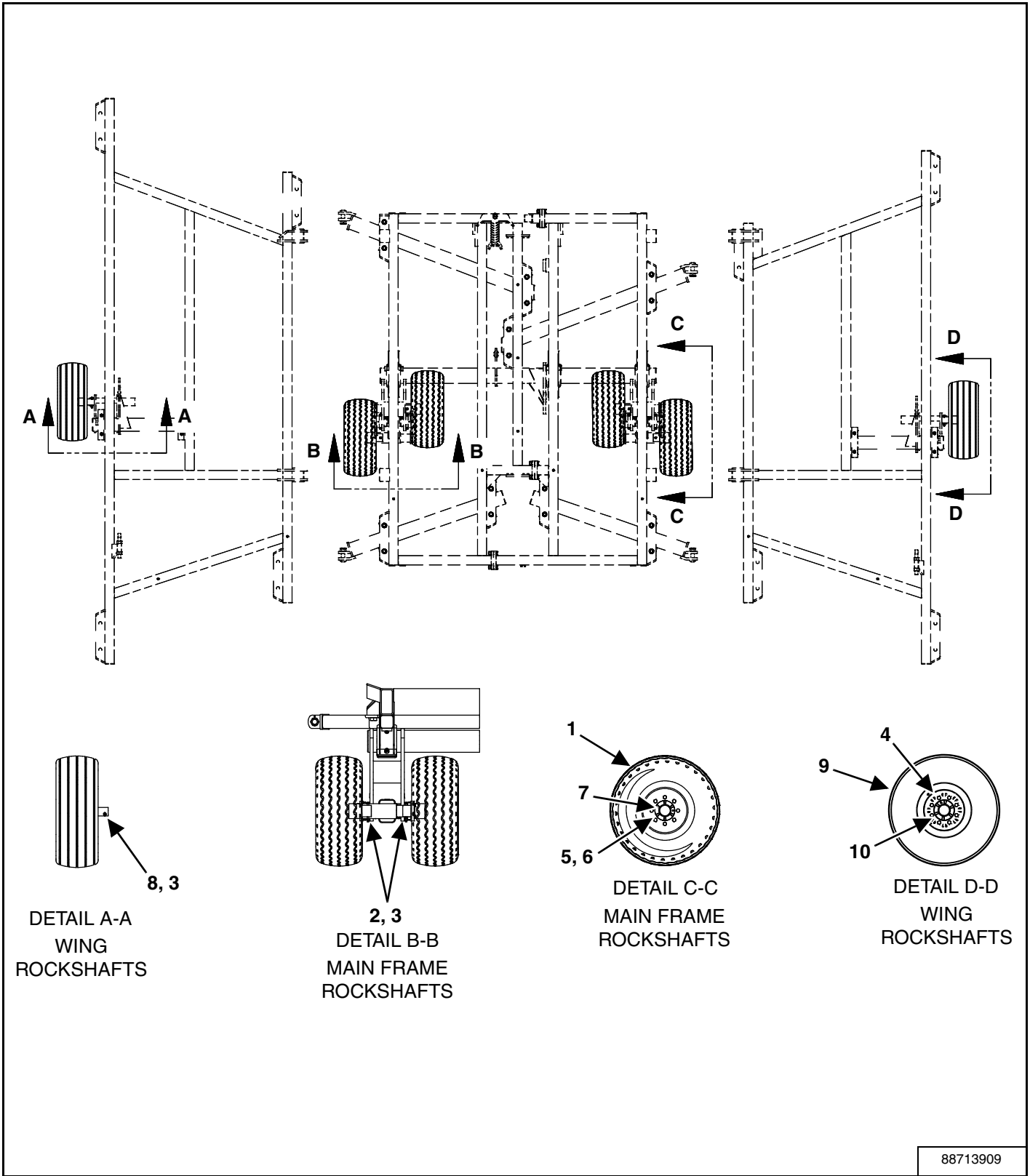

88713909

ITEM	PART NUMBER	DESCRIPTION	QTY
1	88712600	ASSY, FS24 - 380/55R16.5 - 8 BOLT	4
2	EZB050055	BOLT, 1/2" NC x 5.5" HEX CAP GR 5 ZNCR	4
3	EZBN050L	LOCK NUT, 1/2" NC NYL, HEX ZNCR	6
4	88712617	HUB WING SPINDLE ASSEMBLY 812	2
5	EZDR9670	NUT, HEX 9/16" NC PLATED	32
6	EZDR9671	BOLT, WHEEL 9/16" NF x 1-11/16"	32
7	88712588	8 BOLT LARGE SPINDLE ASSEMBLY	4
8	EZB050045	BOLT, 1/2" NC x 4-1/2" HEX CAP GR 5 ZNCR	2
9	88713885	TIRE, 12.5L15FID 8 BOLT RIM	2
10	EZDR125	BOLT, WHEEL 9/16" NF x 1-1/8"	16

Tire Assembly - Narrow

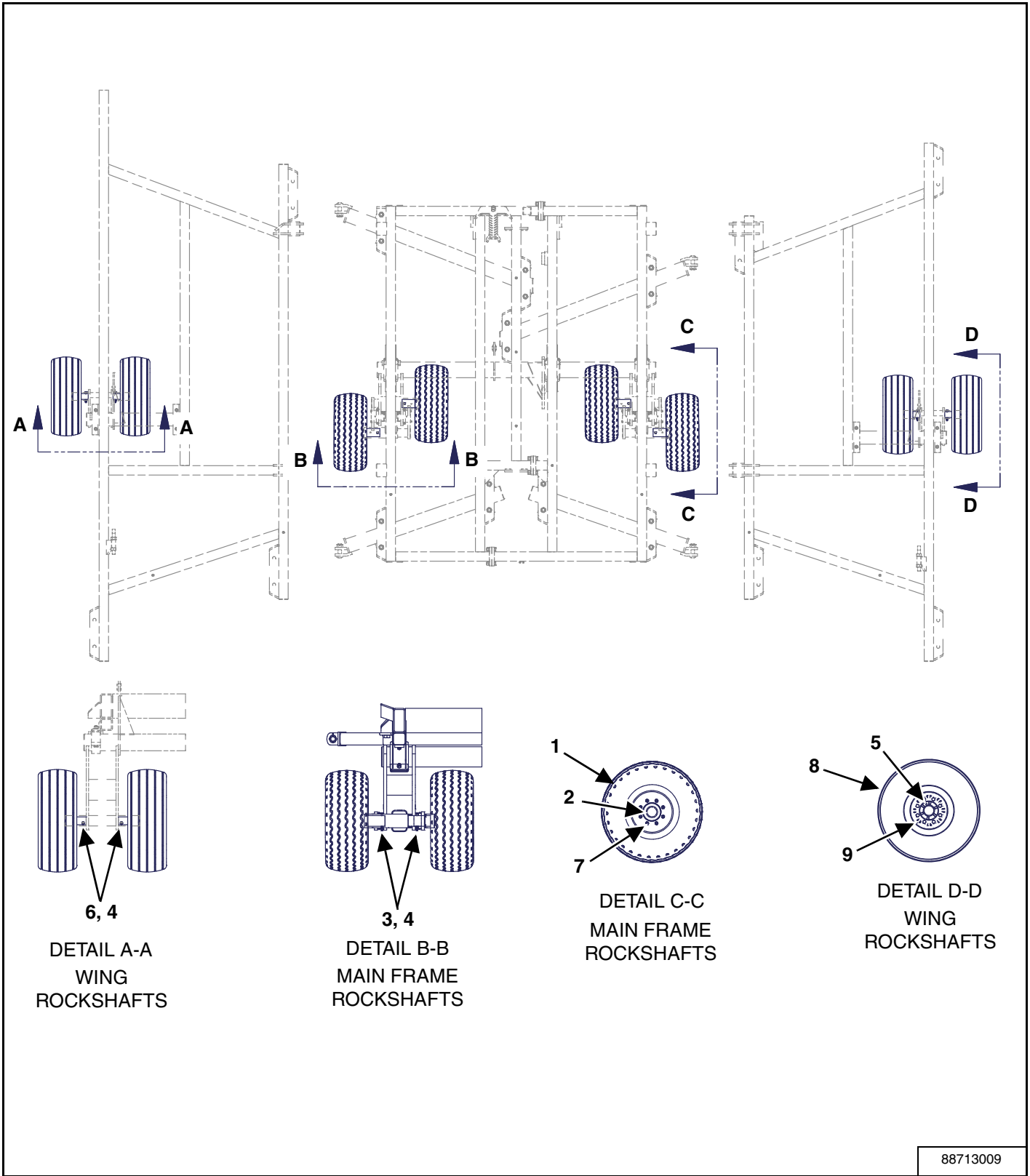

88713009

ITEM	PART NUMBER	DESCRIPTION	QTY
1	88712600	8 BOLT ASSEMBLY, FS24 - 380/55R16.5	4
2	88712582	HUB CTD H817 ASSEMBLY	4
3	EZB050055	BOLT, HEX CAP 1/2" NC x 5.5" GRADE 5 ZNCR	4
4	EZBN050L	LOCK NUT, 1/2" NC NYL, HEX ZNCR	8
5	88712617	HUB WING SPINDLE ASSEMBLY 812	4
6	EZB050045	BOLT, HEX CAP, 1/2" NC x 4-1/2" GR 5 ZNCR	4
7	EZA77043	WHEEL NUT, 5/8" NF	32
8	88713885	TIRE, 12.5L15FID 8 BOLT RIM	4
9	EZDR125	BOLT, WHEEL 9/16" NF x 1-1/8"	32

Tire Assembly - Wide

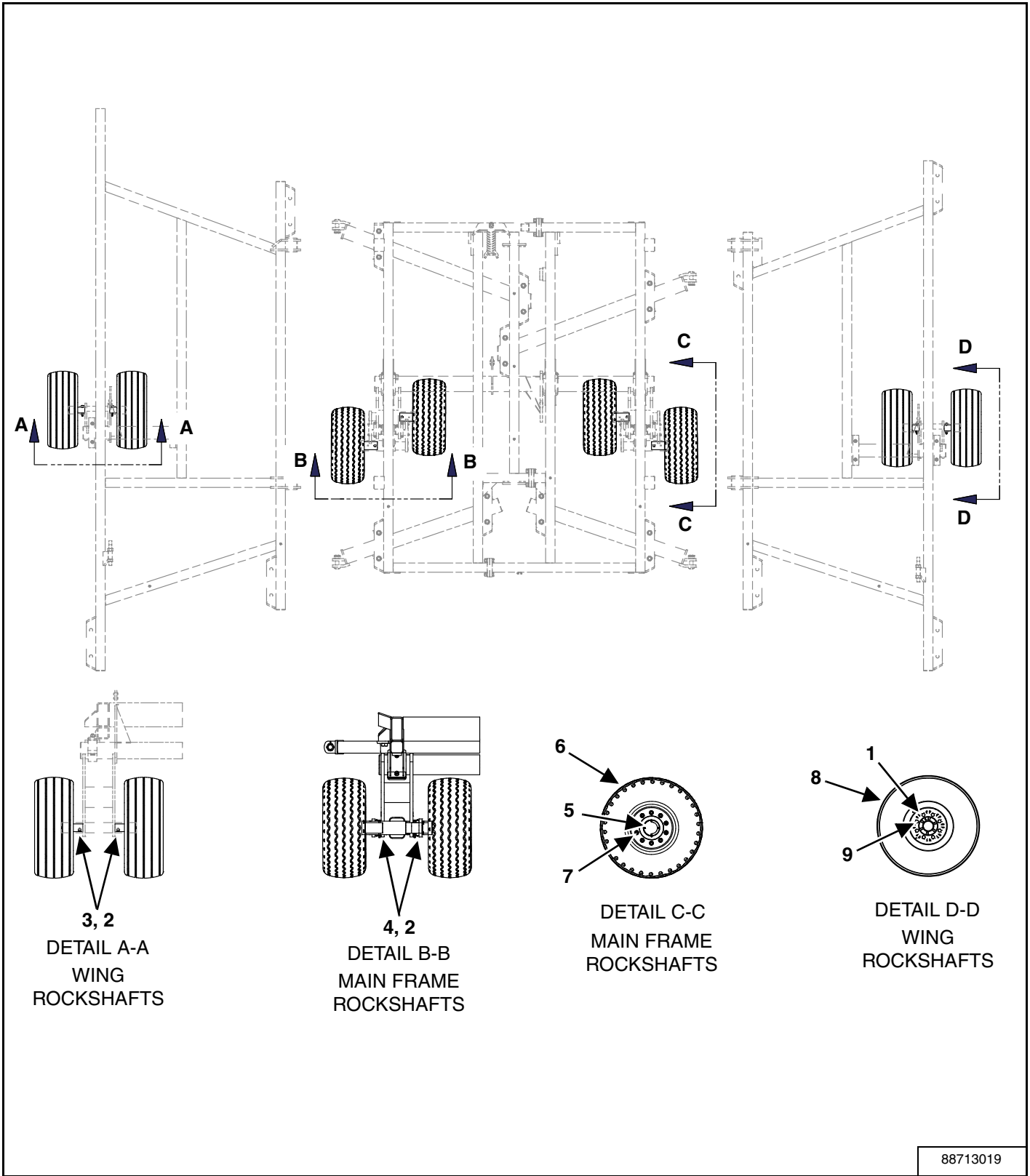

88713019

ITEM	PART NUMBER	DESCRIPTION	QTY
1	88712617	HUB WING SPINDLE ASSEMBLY 812	4
2	EZBN050L	LOCK NUT, 1/2" NC NYL, HEX ZNCR	8
3	EZB050045	BOLT, HEX CAP 1/2" NC x 4-1/2" GR 5 ZNCR	4
4	EZB050055	BOLT, HEX CAP 1/2" NC x 5.5" GR 5 ZNCR	4
5	88706266	10 BOLT HUB ASSEMBLY W / SPINDLE	4
6	88712590	10 BOLT ASSEMBLY, FS24 440/55R18	4
7	EZA70545	NUT, HEX FLANGE 3/4" NF	40
8	88713885	TIRE, 12.5L15FID 8 BOLT RIM	4
9	EZDR125	BOLT, WHEEL 9/16" NF x 1-1/8"	32

Hydraulic Components - Super Narrow Frame

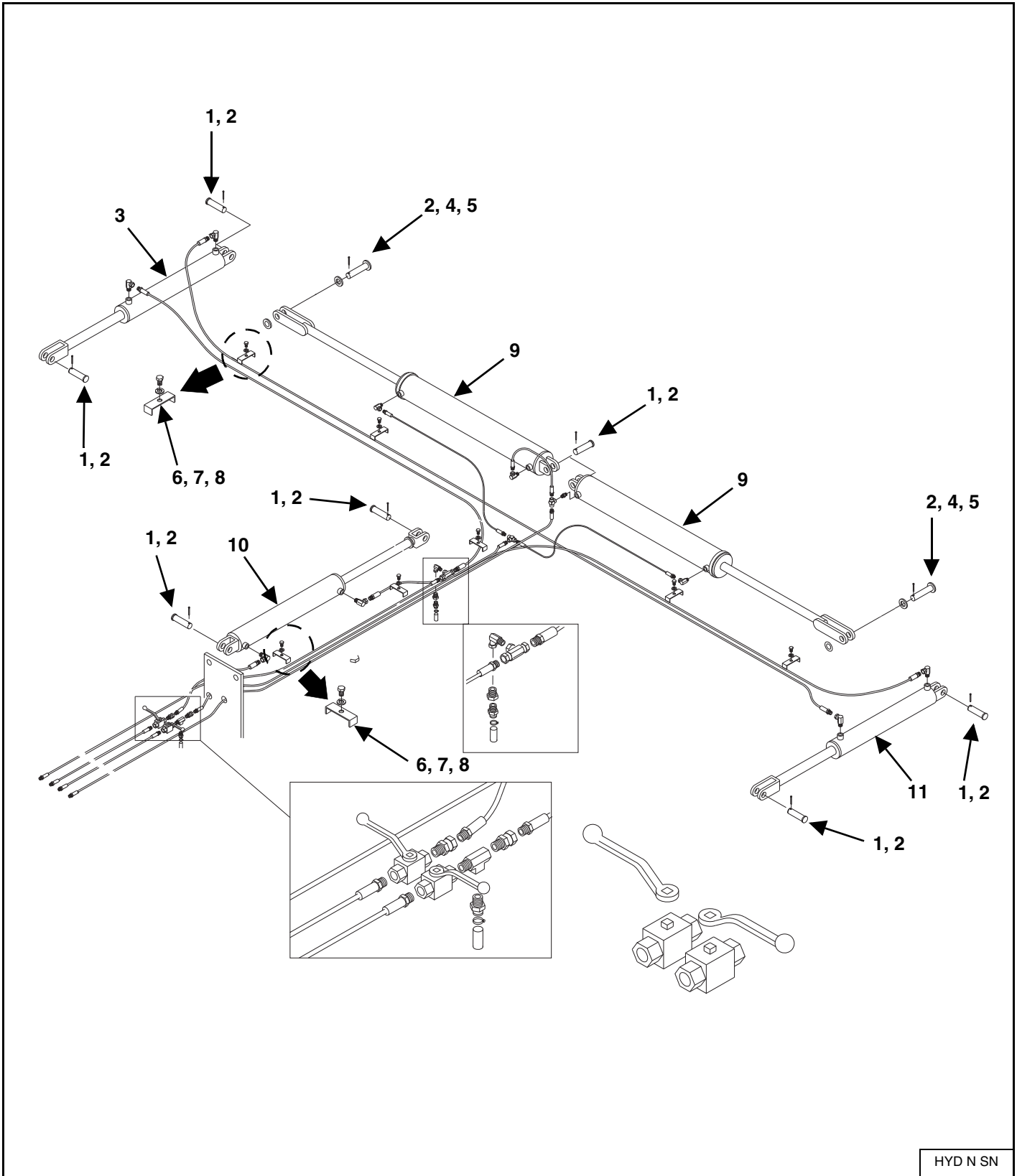

HYD N SN

ITEM	PART NUMBER	DESCRIPTION	QTY
1	EZDR5262	PIN, CYLINDER	8
2	EZBP31175	PIN, COTTER, 5/16" x 1-3/4"	10
3	EZ304	CYLINDER ASSEMBLY, REPHASING 3" DIA x 24" STROKE	1
4	EZDF5068	WASHER, 1-9/32" ID x 2" OD x 1/4"	4
5	EZS81856	PIN, CYLINDER 1 1/4 x 4-3/4 LG	2
6	EZDL13186	HOSE CLAMP, 4 LINE	9
7	EZBW050L	LOCK WASHER, 1/2" x 7/8" x 1/8" ZNCR	9
8	87670	BOLT, 1/2" x 1-1/4" CSHH GR 5 PL 86505344	9
9	EZ248	WING LIFT CYLINDER, 4" x 36"	2
10	EZ306	CYLINDER ASSEMBLY, REPHASING 4" DIA x 24" STROKE	1
11	EZ305	CYLINDER ASSEMBLY, REPHASING 3-1/2" DIA x 24" STROKE	1
12	EZDL13099	BALL VALVE, GE2 - N 3/8" 2 WAY	2

Hydraulic Plumbing - Super Narrow Frame

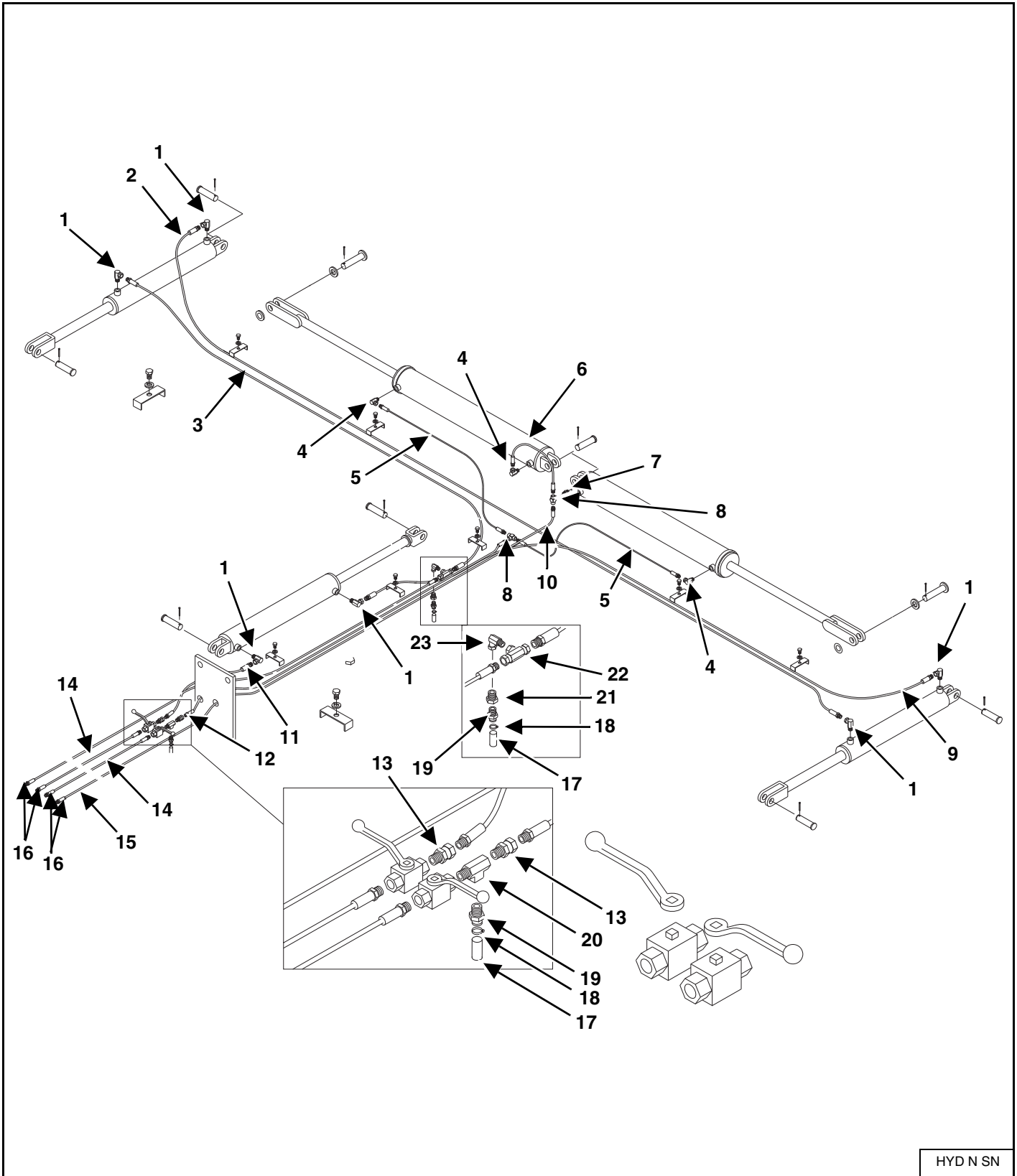

ITEM	PART NUMBER	DESCRIPTION	QTY
1	EZDL9775	SWIVEL STREET ELBOW, 1/2" 90 DEGREE	6
2	EZD4500	HOSE ASSY, 254" LG.	1
3	EZD4499	HOSE ASSY, 401" LG.	1
4	EZDL9769	SWIVEL STREET ELBOW, 3/8" 90 DEGREE	3
6	EZL2939	HOSE ASSY, 24" LG.	1
5	EZP3027	HOSE ASSY, 54" LG.	2
7	EZL1720	MALE UNION	1
8	EZDL9767	SWIVEL TEE, 3/8" x 3/8" x 3/8"	2
9	EZD4501	HOSE ASSY, 190" LG.	1
11	EZD4525	HOSE ASSY, 24" LG.	1
12	EZL3092	HOSE ASSY, 100" LG.	1
13	EZL1619	MALE-FEMALE SWIVEL, 3/8" (9.39mm)	2
14	EZD4335	HOSE ASSY, 172" LG.	2
15	EZD4334	HOSE ASSY, 287" LG.	1
16	EZL397	COUPLER 1/2", MALE NIPPLE	4
17	88716792	DRAIN HOSE, WING CYL RELIEF, VT	2
18	21193	CLAMP HOSE, 14.2	2
19	88717002	CHECK VALVE, 4500 PSI CRK, 6 MNPT x 1/2" HB	2
20	86056528	RUN TEE, 3/8" NPTF	1
21	EZP80702	REDUCER, 1/2" x 3/8"	1
22	EZDL9776	TEE, 1/2" FPX x 1/2" FPX x 1/2" FP	1
23	EZDL9775	90° SWIVEL STREET ELBOW, 1/2"	1
NS	88964	BOLT, 5/16" x 4" UNC GRADE 5	2
NS	80681	LOCK WASHER, P 0.3125 86505602	2
NS	9635082	NUT, GR 5 P 0.3125 86505597	2
NS	88704516	TIE, HYD RAISE / LOWER GR	2
NS	88704517	TIE, HYD WING FOLD BL	2
NS	EZC50716	PACKAGE, WADLER DEPTH STOPS	2
NS	2747	TIE STRAP, 14.4" OLG NYLON B1	AR

Hydraulic Components - Narrow Frame

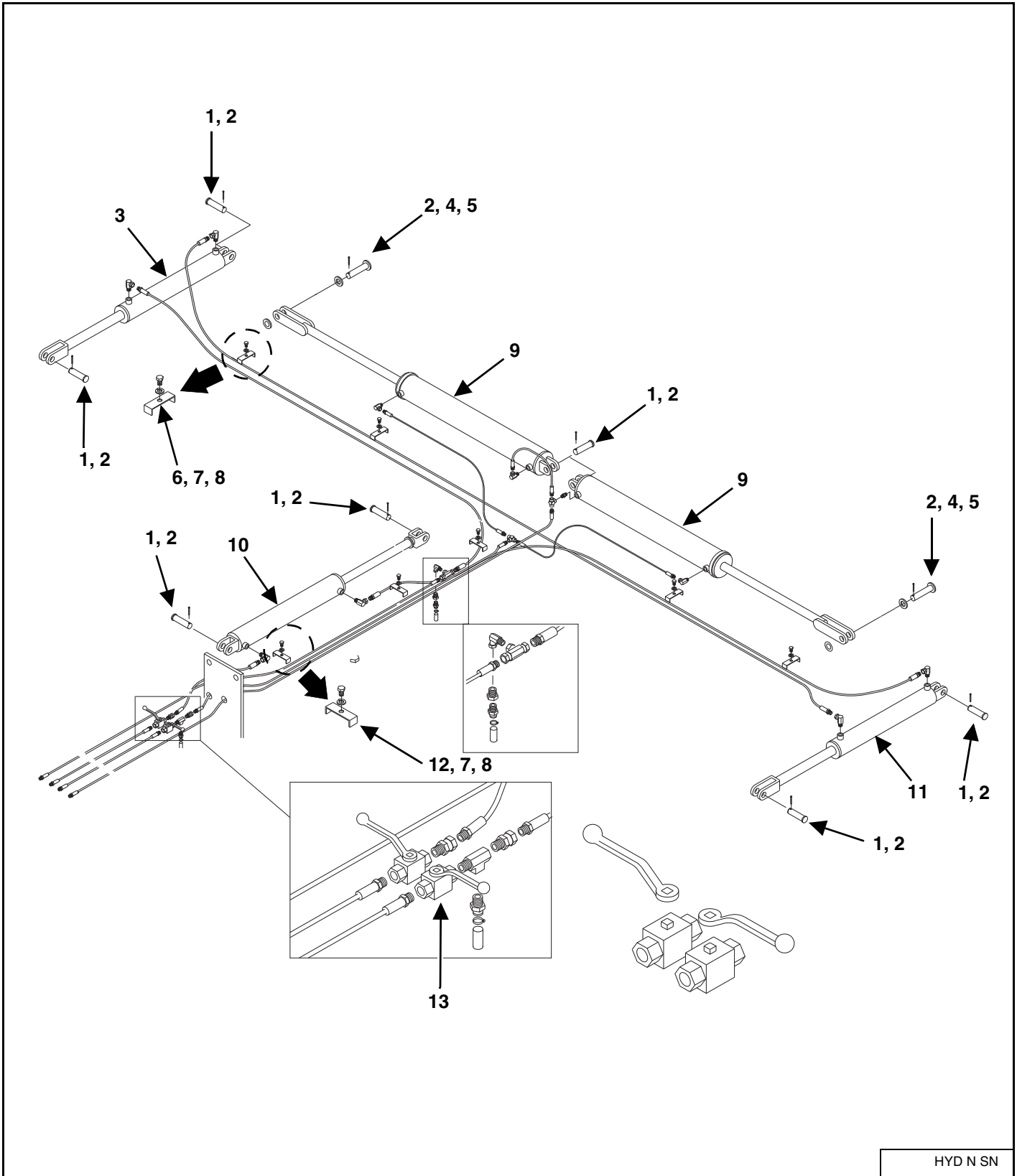

HYD N SN

ITEM	PART NUMBER	DESCRIPTION	QTY
1	EZDR5262	PIN, CYLINDER	10
2	EZBP31175	COTTER PIN, 5/16" x 1-3/4"	10
3	EZ304	CYLINDER ASSEMBLY, REPHASING 3" DIA x 24" STROKE	1
4	EZDF5068	WASHER, 1-9/32" ID x 2" OD x 1/4"	4
5	EZS81856	CYLINDER PIN, 1-1/4" x 4-3/4" LG	2
6	EZDL9771	HOSE RETAINER	6
7	EZBW050L	LOCK WASHER, 1/2" x 7/8" x 1/8" ZNCR	9
8	87670	BOLT, 1/2" x 1.25" CSHH GR 5 P 86505344	9
9	EZ332	WING LIFT CYLINDER, 5" x 36"	2
10	EZ306	CYLINDER ASSEMBLY, REPHASING 4" DIA x 24" STROKE	1
11	EZ305	CYLINDER ASSEMBLY, REPHASING 3-1/2" DIA x 24" STROKE	1
12	EZDL13186	HOSE CLAMP, 4 LINE	3
13	EZDL13099	BALL VALVE, GE2 - N 3/8" 2 WAY	2

Hydraulic Plumbing - Narrow Frame

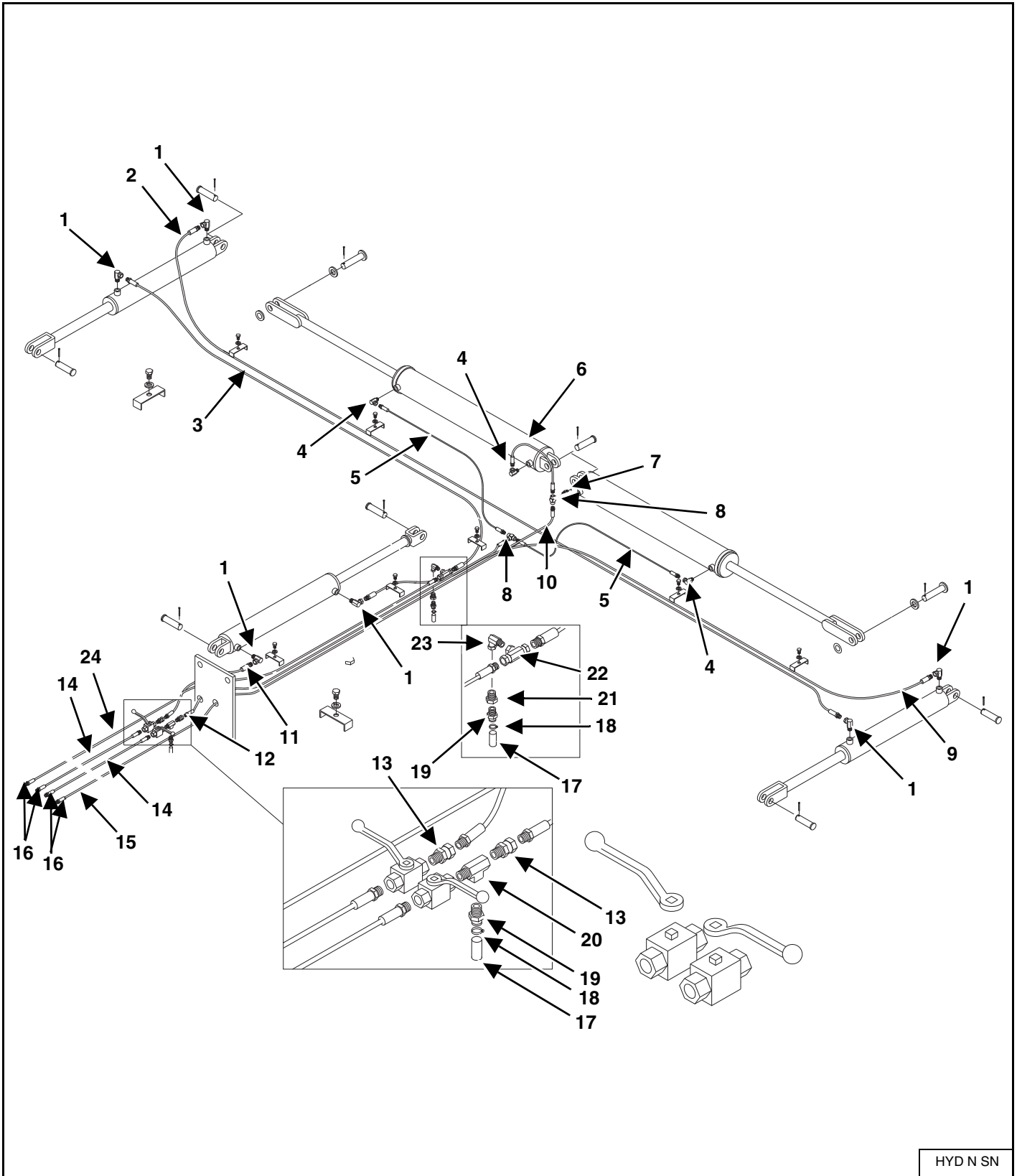

HYD N SN

ITEM	PART NUMBER	DESCRIPTION	QTY
1	EZDL9775	SWIVEL STREET ELBOW, 1/2" 90 DEGREE	6
2	EZD4331	HOSE ASSY, 288" LG.	1
3	88717585	HOSE ASSY, 163" LG.	1
4	EZDL9769	SWIVEL STREET ELBOW, 3/8" 90 DEGREE	3
6	EZL2939	HOSE ASSY, 24" LG.	1
5	EZP3027	HOSE ASSY, 54" LG.	2
7	EZL1720	MALE-MALE UNION	1
8	EZDL9767	SWIVEL TEE, 3/8" x 3/8" x 3/8"	2
9	EZD4432	HOSE ASSY, 207" LG.	1
11	EZD4525	HOSE ASSY, 24" LG.	1
12	EZL3092	HOSE ASSY, 100" LG.	1
13	EZL1619	MALE-FEMALE SWIVEL, 3/8" (9.39 mm)	2
14	EZD4335	HOSE ASSY, 172" LG.	2
15	EZD4334	HOSE ASSY, 287" LG.	1
16	EZL397	COUPLER 1/2", MALE NIPPLE	4
17	88716792	DRAIN HOSE, WING CYL RELIEF, VT	2
18	21193	CLAMP HOSE, 14.2	2
19	88717002	CHECK VALVE, 4500 PSI CRK, 6 MNPT x 1/2" HB	2
20	86056528	RUN TEE, 3/8" NPTF	1
21	EZP80702	REDUCER, 1/2" x 3/8"	1
22	EZDL9776	TEE, 1/2" FPX x 1/2" FPX x 1/2" FP	1
23	EZDL9775	90° SWIVEL STREET ELBOW, 1/2"	1
24	88717569	HOSE ASSY, 263" LG.	1
NS	88964	BOLT, 5/16" x 4 UNC GR 5	2
NS	80681	LOCK WASHER, P 0.3125 86505602	2
NS	9635082	NUT, GR 5 P 0.3125 86505597	2
NS	88704516	TIE, HYD RAISE / LOWER GR	2
NS	88704517	TIE, HYD WING FOLD BL	2
NS	EZC50716	PACKAGE, WADLER DEPTH STOPS	2
NS	2747	TIE STRAP, 14.4" OLG NYLON B1	AR

Hydraulic Components - Wide Frame

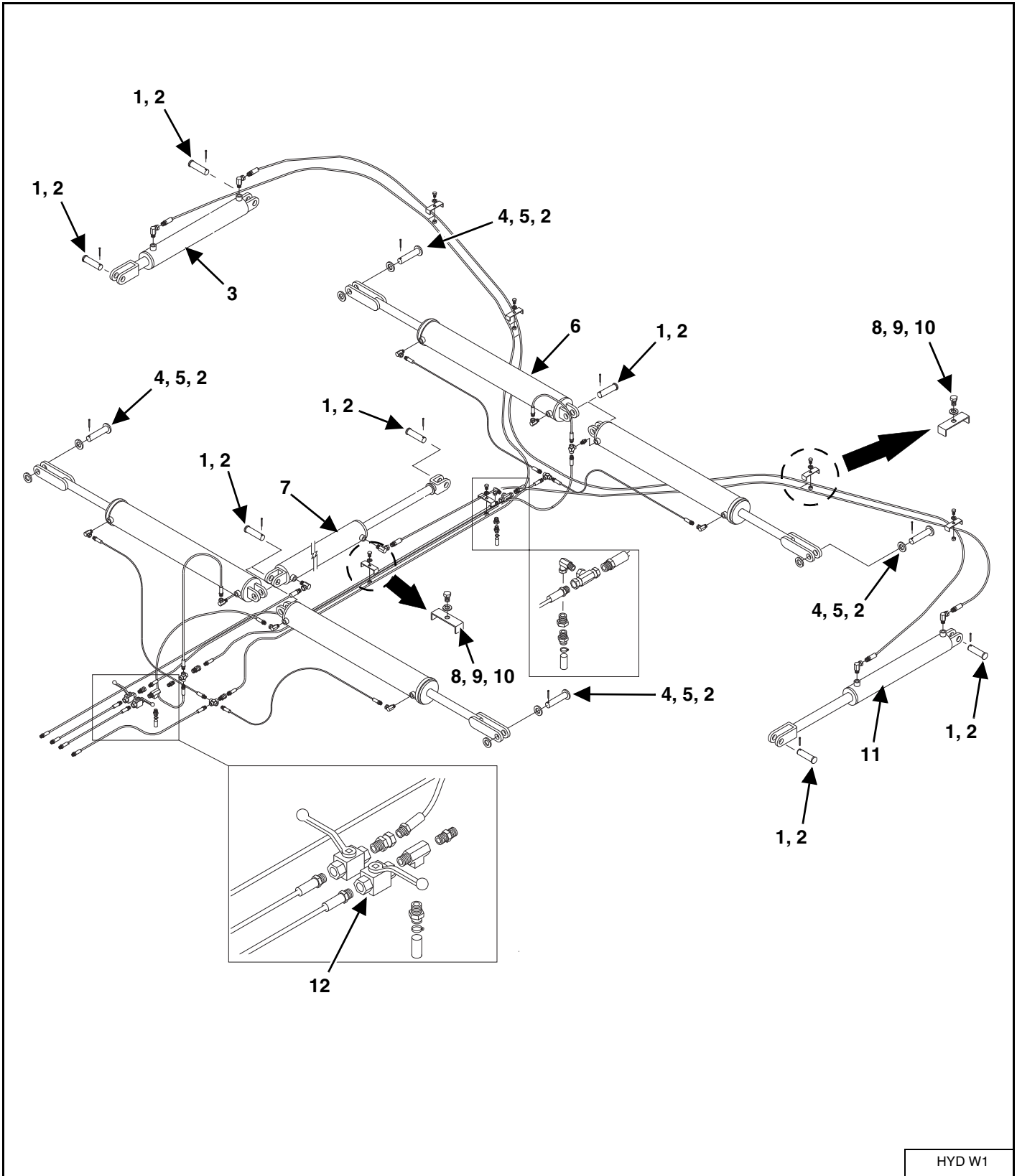

ITEM	PART NUMBER	DESCRIPTION	QTY
1	EZDR5262	PIN, CYLINDER	10
2	EZBP31175	PIN, COTTER, 5/16" x 1-3/4"	14
3	EZ305	CYLINDER ASSEMBLY, REPHASING 3-1/2" DIA x 24" STROKE	1
4	EZS81856	PIN, CYLINDER 1-1/4" x 4-3/4" LG	4
5	EZDF5068	WASHER, 1-9/32" ID x 2" OD x 1/4"	8
6	EZ332	WING LIFT CYLINDER, 5" x 36"	4
7	EZ341	CYLINDER ASSEMBLY, REPHASING 4-1/2" x 24" STROKE	1
8	EZDL13186	HOSE CLAMP, 4 LINE	11
9	EZBW050L	LOCK WASHER, 1/2" x 7/8" x 1/8" ZNCR	11
10	87670	BOLT, CSHH G5 P 1/2" x 1-1/4" 86505344	11
11	EZ306	CYLINDER ASSEMBLY, REPHASING 4" DIA x 24" STROKE	1
12	EZDL13099	BALL VALVE, GE2 - N 3/8" 2 WAY	2

Hydraulic Plumbing - Wide Frame

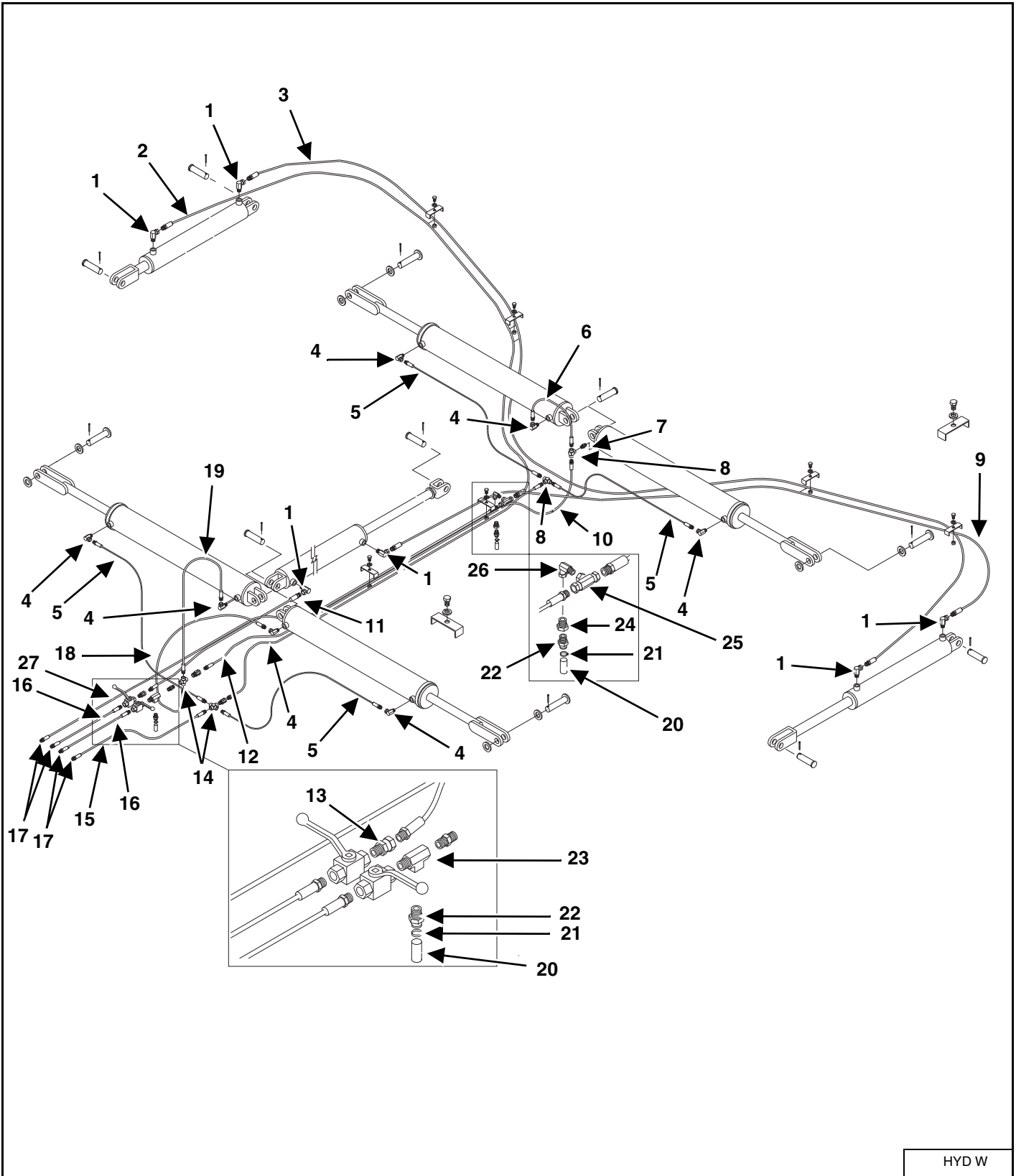

ITEM	PART NUMBER	DESCRIPTION	QTY
1	EZDL9775	SWIVEL STREET ELBOW, 1/2" 90 DEGREE	6
2	88717569	HOSE ASSY, 225" LG.	1
3	EZD4430	HOSE ASSY, 410" LG.	1
4	EZDL9769	SWIVEL STREET ELBOW, 3/8" 90 DEGREE	7
5	EZP3027	HOSE ASSY, 54" LG.	4
6	EZL2939	HOSE ASSY, 24" LG.	1
7	EZL1720	MALE-MALE UNION	2
8	EZDL9767	SWIVEL TEE, 3/8" x 3/8" x 3/8"	2
9	EZD4340	HOSE ASSY, 253" LG.	1
10	EZD4486	HOSE ASSY, 110" LG.	1
11	EZD4525	HOSE ASSY, 24" LG.	1
12	EZL3092	HOSE ASSY, 100" LG.	1
13	EZL1619	MALE-FEMALE SWIVEL, 3/8" (9.39 mm)	3
14	EZDL9761	CROSS, STEEL, 3/8"	2
15	EZD4341	HOSE ASSY, 178" LG.	1
16	EZD4335	HOSE ASSY, 172" LG.	2
17	EZL397	MALE NIPPLE COUPLER 1/2"	4
18	EZL2937	HOSE ASSY, 30" LG.	1
19	EZD4436	HOSE ASSY, 20" LG.	1
20	88716792	DRAIN HOSE, WING CYL RELIEF, VT	2
21	21193	CLAMP HOSE, 14.2	2
22	88717002	CHECK VALVE, 4500 PSI CRK, 6 MNPT x 1/2" HB	2
23	86056528	RUN TEE, 3/8" NPTF	1
24	EZP80702	REDUCER, 1/2" x 3/8"	1
25	EZDL9776	TEE, 1/2" FPX x 1/2" FPX x 1/2" FP	1
26	EZDL9775	90° SWIVEL STREET ELBOW, 1/2"	1
27	88717569	HOSE ASSY, 263" LG.	1
NS	88704516	TIE, HYD RAISE / LOWER GR	2
NS	88704517	TIE, HYD WING FOLD BL	2
NS	2747	TIE STRAP, 14.4" OLG NYLON B1	AR
NS	EZC50716	WADLER DEPTH STOP PACKAGE	2
NS	88964	BOLT, 5/16" x 4" UNC GRADE 5	2
NS	80681	LOCK WASHER, P 0.3125 86505602	2
NS	9635082	NUT, GR 5 P 0.3125 86505597	2

Wing Lift Cylinder - 4 In. x 36 In. (102 x 914 mm)

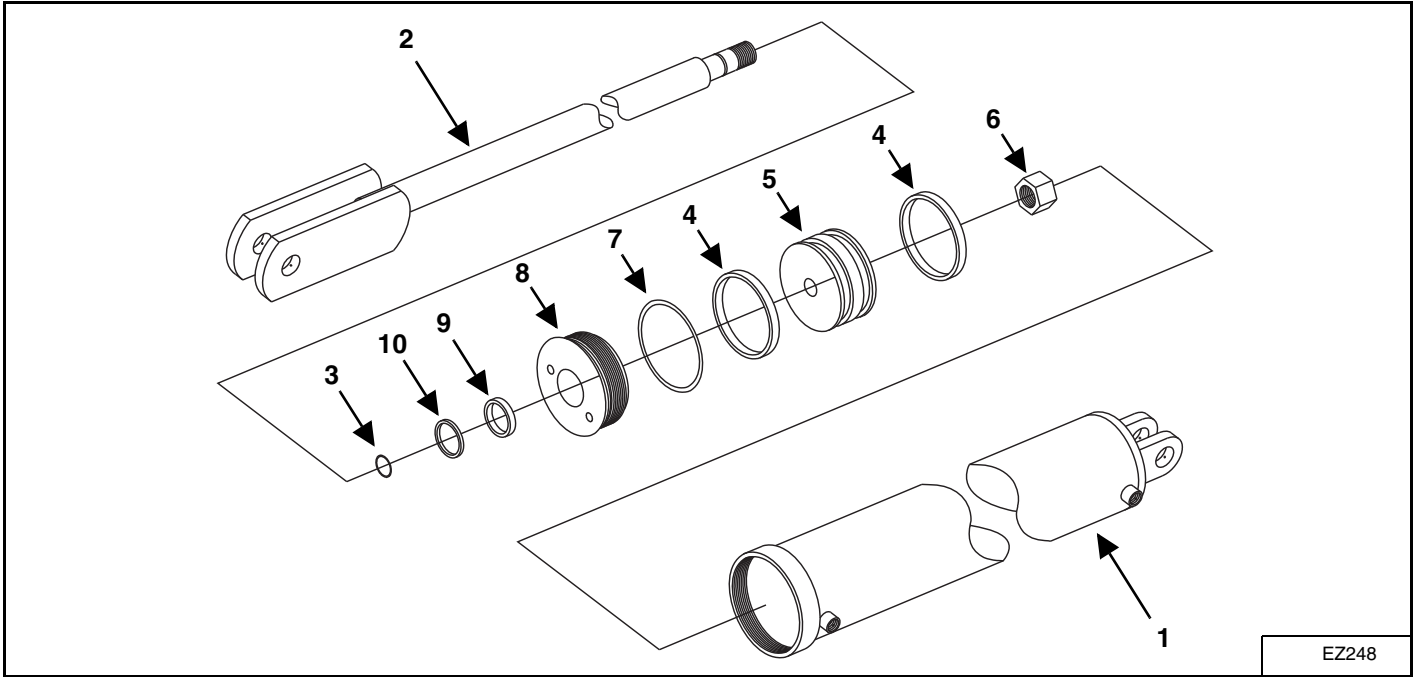

EZ248

ITEM	PART NUMBER	DESCRIPTION	QTY
1	EZ40TU8	TUBE ASSEMBLY 4" x 36" (102 x 914 mm)	1
2	EZ10SH36	SHAFT 1-3/4" x 36" (44.4 x 914 mm)	1
3	EZ10OR19	O-RING, 1-1/8" I.D. x 1-1/4" O.D. (28.5 x 31.8 mm)	1
4	EZ40CU3	U-CUP, 4" (101.6 mm)	2
5	EZ40PB7	PISTON, 4" O.D. x 1-1/4" I.D. (101.6 x 31.7 mm)	1
6	EZ10NU3	LOCK NUT, 1-1/4" (31.8 mm) U.N.F. HEX	1
7	EZ10OR17	O-RING, 3-5/8" I.D. x 4" O.D. (92.1 x 101.6 mm)	1
8	EZ40HP4	HEAD PLATE, 4" O.D. x 1-3/4" I.D. (101.6 x 44.4 mm)	1
9	EZ10RS3	ROS SEAL, 1-3/4" I.D. x 2-1/8" O.D. x 3/8" (44.4 x 54 x 9.39 mm)	1
10	EZ10WS3	WIPER SEAL, 1-3/4" I.D. x 2-1/8" O.D. x 3/16" (44.4 x 54 x 4.76 mm)	1

Wing Lift Cylinder Seal Kit - 4 In. x 36 In. (102 x 914 mm)

PART NUMBER	DESCRIPTION	QTY
EZ4017N4	COMPLETE SEAL KIT	1
EZ40CU3	U-CUP, 4" (101.6 mm) U-Cup	2
EZ100R17	O-RING, 3-5/8" I.D. x 4" O.D. (92.1 x 101.6 mm)	1
EZ100R19	O-RING, 1-1/8" I.D. x 1-1/4" O.D. (28.4 x 31.7 mm)	1
EZ100RS3	ROD SEAL, 1-3/4" I.D. x 2-1/8" O.D. x 3/8" (44.4 x 54 x 9.39 mm)	1
EZ10WS3	WIPER SEAL, 1-3/4" I.D. x 2-1/8" O.D. x 3/16" (44.4 x 54 x 4.76 mm)	1
EZ100R13	O-RING, 1" O.D. x 1-1/4" O.D. (25.4 x 31.8 mm)	1

Wing Lift Cylinder - 5 In. x 36 In. (127 x 914 mm)

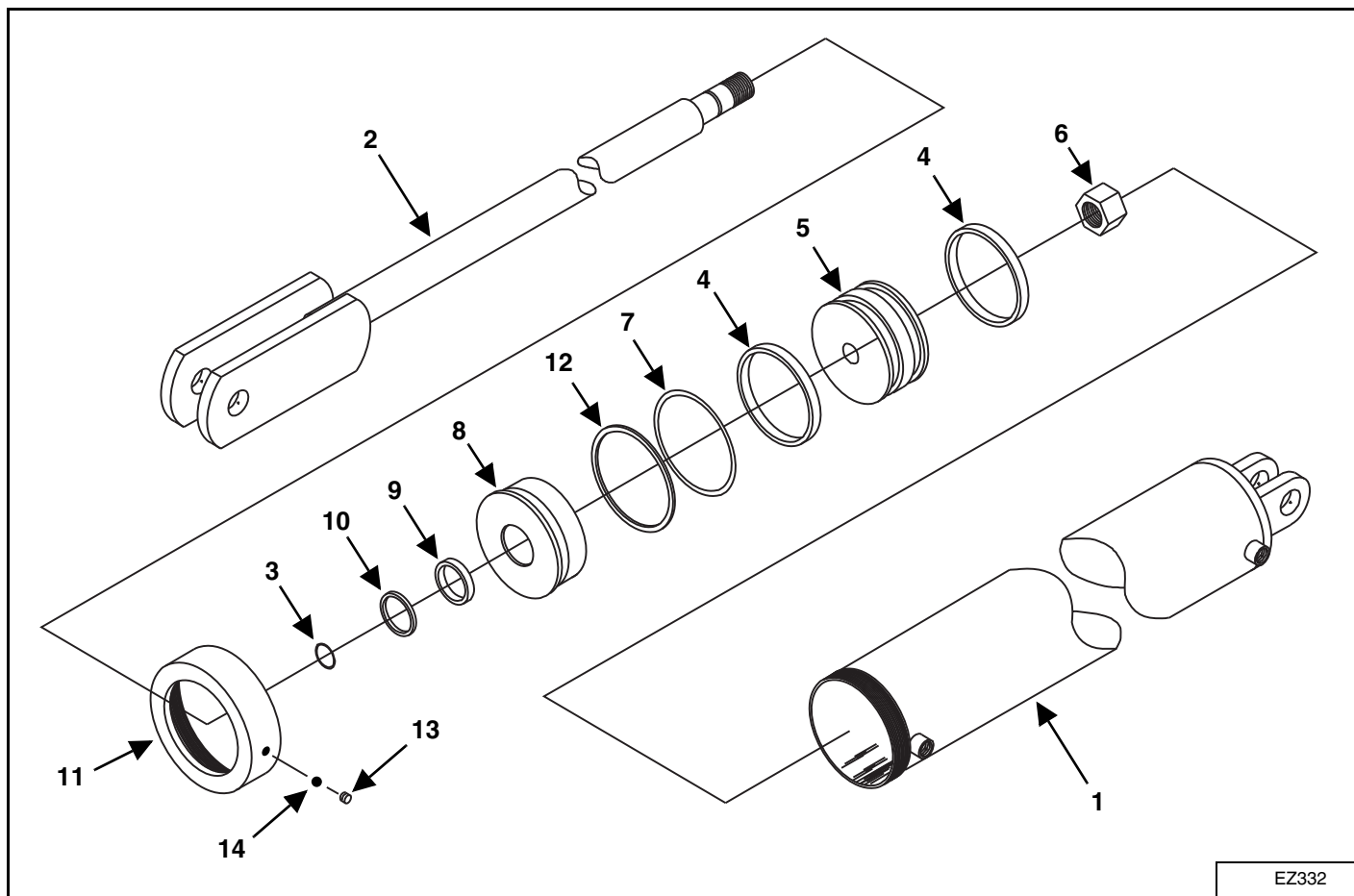

EZ332

ITEM	PART NUMBER	DESCRIPTION	QTY
1	EZ50TU11	N3 TUBE ASSEMBLY, 5" x 36" (127 x 914 mm)	1
2	EZ10SH36	SHAFT, 1-3/4" x 36" (44.4 x 914 mm)	1
3	EZ100R19	O-RING, 1-1/8" I.D. x 1-1/4" O.D. (28.5 x 31.8 mm)	1
4	EZ50CU1	U-CUP, 4-1/2" I.D. x 5" O.D. x 1/2" (29.9 x 127 x 12.7 mm)	2
5	EZ50PB2	PISTON, 5" O.D. x 1-1/4" I.D. (127 x 31.8 mm)	1
6	EZ10NU3	LOCK NUT, 1-1/4" (31.8 mm) U.N.F. Hex	1
7	EZ100R14	O-RING, 4-1/2" I.D. x 5" O.D. (29.9 x 127 mm)	1
8	EZ50HP5	N3 HEAD PLATE, 5" O.D. x 1-3/4" O.D. (127 x 44.4 mm)	1
9	EZ10RS3	ROD SEAL, 1-3/4" I.D. x 2-1/8" O.D. x 3/8" (44.4 x 54 x 9.39 mm)	1
10	EZ10WS3	WIPER SEAL, 1-3/4" I.D. x 2-1/8" O.D. x 3/16" (44.4 x 54 x 4.76 mm)	1
11	EZ50HN1	N3 HEAD NUT, 5"	1
12	EZ50BR1	BACKUP RING, 5" O.D. x 4-1/2" I.D. (127 x 114 mm)	1
13	EZA70658	SET SCREW, 1/4" - 28 SOCKET HEAD	1
14	EZ10SS2	SET SCREW, 3/16" BALL LOCK	1

Wing Lift Cylinder Seal Kit - 5 In. x 36 In. (127 x 914 mm)

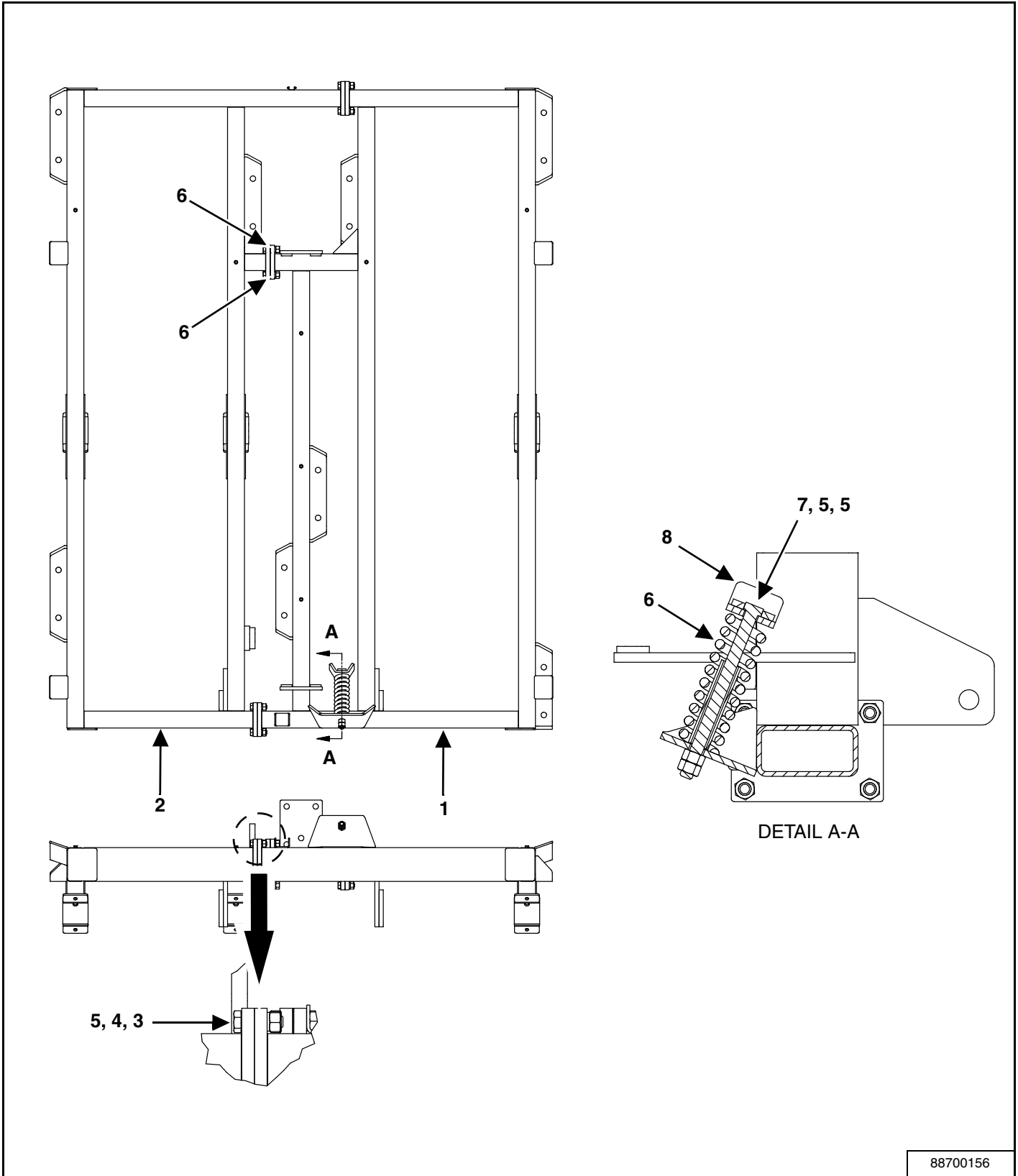

88700156

PART NUMBER	DESCRIPTION	QTY
EZ5017N3	COMPLETE SEAL KIT	1
EZ50CU1	U-CUP, 4-1/2" I.D. x 5" O.D. x 1/2" (114 x 127 x 12.7 MM)	2
EZ100R14	O-RING, 4-1/2" I.D. x 5" O.D. (114 x 127 MM)	1
EZ100R19	O-RING, 1-1/8" I.D. x 1-1/4" O.D. (28.5 x 31.8 MM)	1
EZ100RS3	ROD SEAL, 1-3/4" I.D. x 2-1/8" O.D. x 3/8" (44.4 x 54.0 x 9.39 MM)	1
EZ10WS3	WIPER SEAL, 1-3/4" I.D. x 2-1/8" O.D. x 3/16" (44.4 x 54.0 x 4.76 MM)	1
EZ50BR1	BACKUP RING, 5" O.D. x 4-1/2" I.D.	1
EZ10SS2	SET SCREW, 3/16" BALL LOCK	1

Main Rockshaft Cylinder - 4 In. x 24 In. (101.6 x 610 mm)

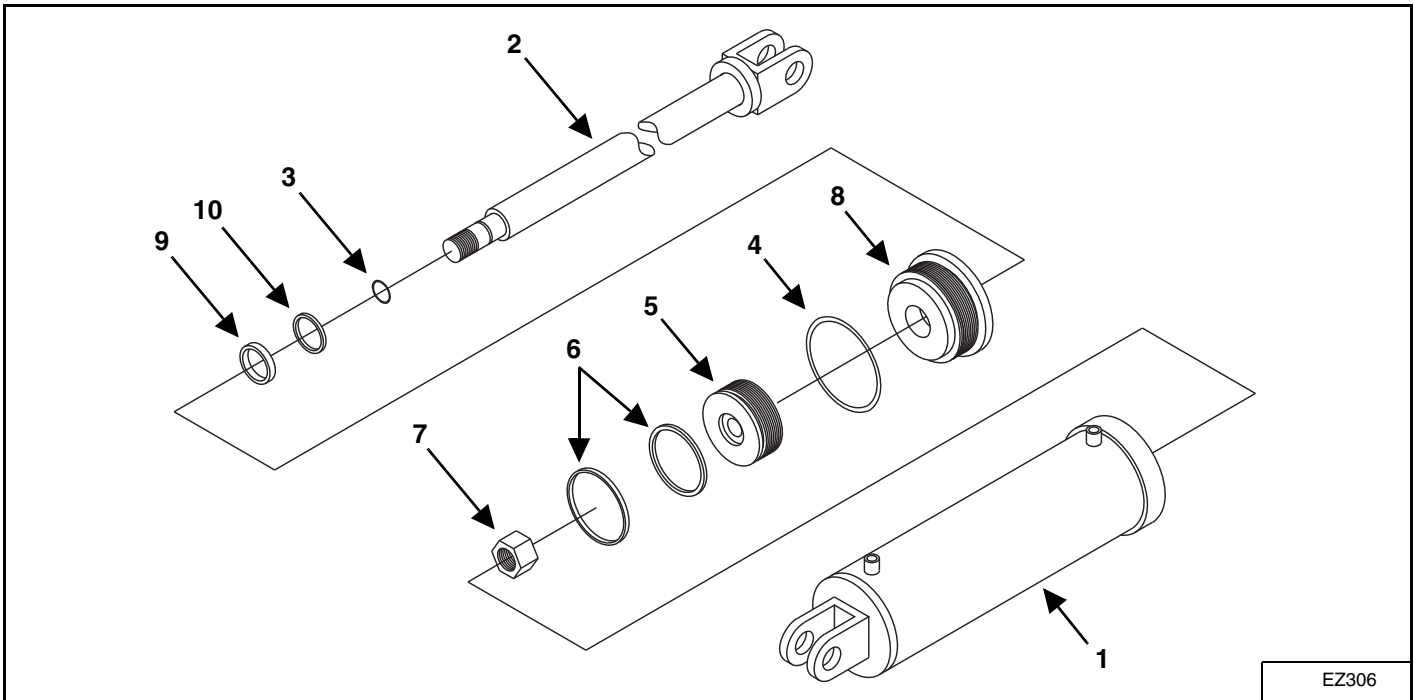

EZ306

ITEM	PART NUMBER	DESCRIPTION	QTY
1	EZ40TU10	TUBE ASSEMBLY, 4" (101.6 mm) x 24" (610 mm)	1
2	EZ10SH60	SHAFT, 2" (50.8 mm) x 24" (610 mm)	1
3	EZ10OR18	O-RING, 1" (25.4 mm) O.D. x 7/8" (22.2 mm) I.D.	1
4	EZ10OR17	O-RING, 4" (101.6 mm) O.D. x 3/16" (4.76 mm)	1
5	EZ40PB8	PISTON, 4" (101.6mm) O.D. x 1" (25.4mm) I.D.	1
6	EZ40PS1	PISTON SEAL ASSEMBLY, 4" (101.6 mm) O.D.	2
7	EZ10NU4	NUT, 1" (25.4mm) - 14 N.F.	1
8	EZ40HP5	HEAD PLATE, 4" (101.6 mm) O.D. x 2" (50.8 mm) I.D.	1
9	EZ10RS2	ROD SEAL, 2-3/8" (60.2 mm) O.D. x 2" (50.8 mm) I.D. x 3/8" (9.39 mm)	1
10	EZ10WS6	WIPER SEAL, 2-1/2" (63.5 mm) O.D. x 2" (50.8 mm) I.D. x 3/8" (9.39 mm) (ALL URETHANE)	1

Main Rockshaft Cylinder Seal Kit

PART NUMBER	DESCRIPTION	QTY
EZ4020N4-0	COMPLETE SEAL KIT	1
EZ100R18	O-RING, 1" O.D. x 7/8" I.D. (25.4 x 22.2 mm)	1
EZ100R17	O-RING, 4" O.D. x 3/16" (101.6 x 4.76 mm)	1
EZ40PS1	PISTON SEAL ASSEMBLY, 4" (101.6 mm)	1
EZ10RS2	ROD SEAL, 2-3/8" O.D. x 2" I.D. x 3/8" (60.2 x 50.8 x 9.39 mm)	1
EZ10WS6	WIPER SEAL, 2-1/2" O.D. x 2" I.D. x 3/8" (63.5 x 50.8 x 9.39 mm) (ALL URETHANE)	1

LH Wing Rockshaft Cylinder - 3-1/2 In. x 24 In. (88.9 x 610 mm)

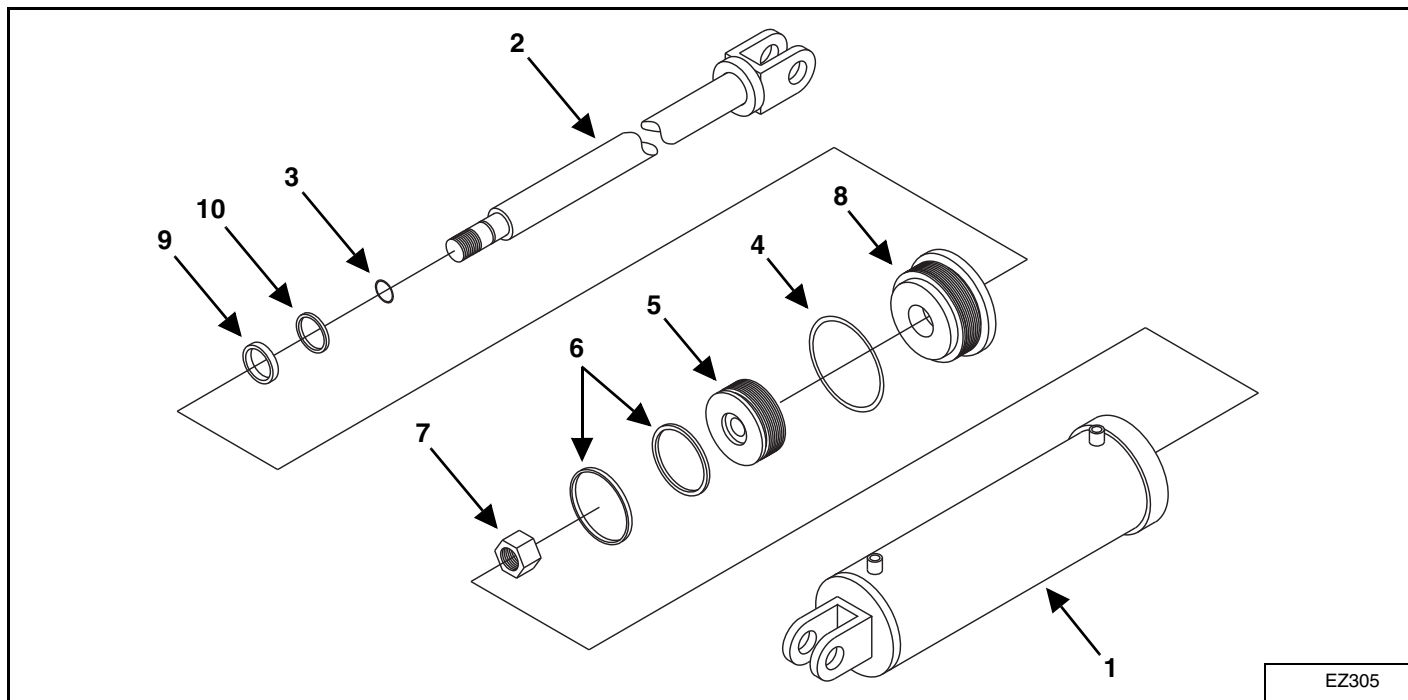

ITEM	PART NUMBER	DESCRIPTION	QTY
1	EZ35TU15	TUBE ASSEMBLY, 3-1/2" (88.9 mm) x 24" (610 mm)	1
2	EZ10SH59	SHAFT, 1-3/4" (44.4 mm) x 24" (610 mm)	1
3	EZ10OR18	O-RING, 1" (25.4 mm) O.D. x 7/8" (22.2 mm) I.D.	1
4	EZ10OR8	O-RING, 3-1/2" (88.9 mm) O.D. x 3/16" (4.76 mm)	1
5	EZ35PB8	PISTON, 3-1/2" (88.9 mm) O.D. x 1" (25.4 mm) I.D.	1
6	EZ35PS1	PISTON SEAL ASSEMBLY	2
7	EZ10NU4	NUT, 1" (25.4 mm) - 14 N.F. HEX	1
8	EZ35HP9	HEAD PLATE, 3-1/2" (88.9 mm) O.D. x 1-3/4" (44.4 mm) I.D.	1
9	EZ10RS3	ROD SEAL, 1-3/4" (44.4 mm) I.D. x 2-1/8" (54 mm) O.D. x 3/8" (9.39 mm)	1
10	EZ10WS10	WIPER SEAL, 1-3/4" (44.4 mm) O.D. x 2-1/8" (54 mm) I.D. x 1/4" (6.35 mm) (ALL URETHANE)	1

LH Rockshaft Cylinder Seal Kit

PART NUMBER	DESCRIPTION	QTY
EZ3517N4-0	COMPLETE SEAL KIT	1
EZ10OR18	O-RING, 1" O.D. x 7/8" I.D. (25.4 x 22.2 mm)	1
EZ10OR8	O-RING, 3-1/2" O.D. x 3/16" (88.9 x 4.76 mm)	1
EZ35PS1	PISTON SEAL ASSEMBLY, 3-1/2" (88.9 mm)	1
EZ10RS3	ROD SEAL, 1-3/4" I.D. x 2-1/8" O.D. x 3/8" (44.4 x 54 x 9.39 mm)	1
EZ10WS10	WIPER SEAL, 1-3/4" I.D. x 2-1/8" O.D. x 1/4" (44.4 x 54 x 6.35 mm) (ALL URETHANE)	1

RH Wing Rockshaft Cylinder - 3 In. x 24 In. (76.2 x 610 mm)

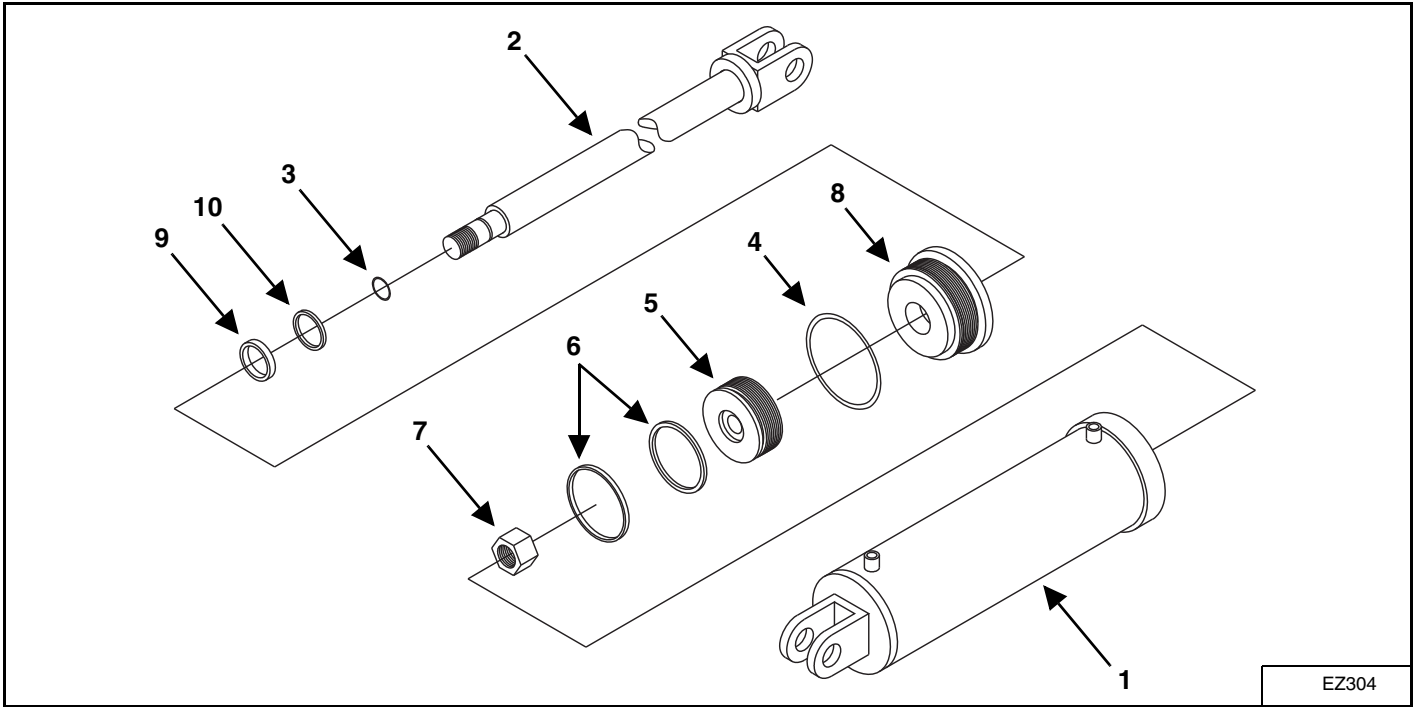

EZ304

ITEM	PART NUMBER	DESCRIPTION	QTY
1	EZ35TU34	TUBE ASSEMBLY, 3" (76.2 mm) x 24" (610 mm)	1
2	EZ10SH59	SHAFT, 1-3/4" (44.4 mm) x 24" (610 mm)	1
3	EZ10OR18	O-RING, 1" (25.4 mm) O.D. x 7/8" (22.2 mm) I.D.	1
4	EZ10OR3	O-RING, 3" (76.2 mm) O.D. x 3/16" (4.76 mm)	1
5	EZ30PB4	PISTON, 3" (76.2 mm) O.D. x 1" (25.4 mm) I.D.	1
6	EZ30PS1	PISTON SEAL ASSEMBLY	2
7	EZ10NU4	NUT, 1" (25.4 mm) - 14 N.F. HEX	1
8	EZ30HP9	HEAD PLATE, 3" (76.2 mm) O.D. x 1-3/4" (44.4 mm) I.D.	1
9	EZ10RS3	ROD SEAL, 1-3/4" (44.4 mm) I.D. x 2-1/8" (54 mm) O.D. x 3/8" (9.39 mm)	1
10	EZ10WS10	WIPER SEAL, 1-3/4" (44.4 mm) O.D. x 2-1/8" (54 mm) I.D. x 1/4" (6.35 mm) (ALL URETHANE)	1

RH Rockshaft Cylinder Seal Kit

PART NUMBER	DESCRIPTION	QTY
EZ3017N4-0	COMPLETE SEAL KIT	1
EZ10OR18	O-RING, 1" O.D. x 7/8" I.D. (25.4 x 22.2 mm)	1
EZ10OR8	O-RING, 3-1/2" O.D. x 3/16" (88.9 x 4.76 mm)	1
EZ35PS1	PISTON SEAL ASSEMBLY, 3-1/2" (88.9 mm)	1
EZ10RS3	ROD SEAL, 1-3/4" I.D. x 2-1/8" O.D. x 3/8" (44.4 x 54 x 9.39 mm)	1
EZ10WS10	WIPER SEAL, 1-3/4" I.D. x 2-1/8" O.D. x 1/4" (44.4 x 54 x 6.35 mm) (ALL URETHANE)	1

Walking Beams Assembly

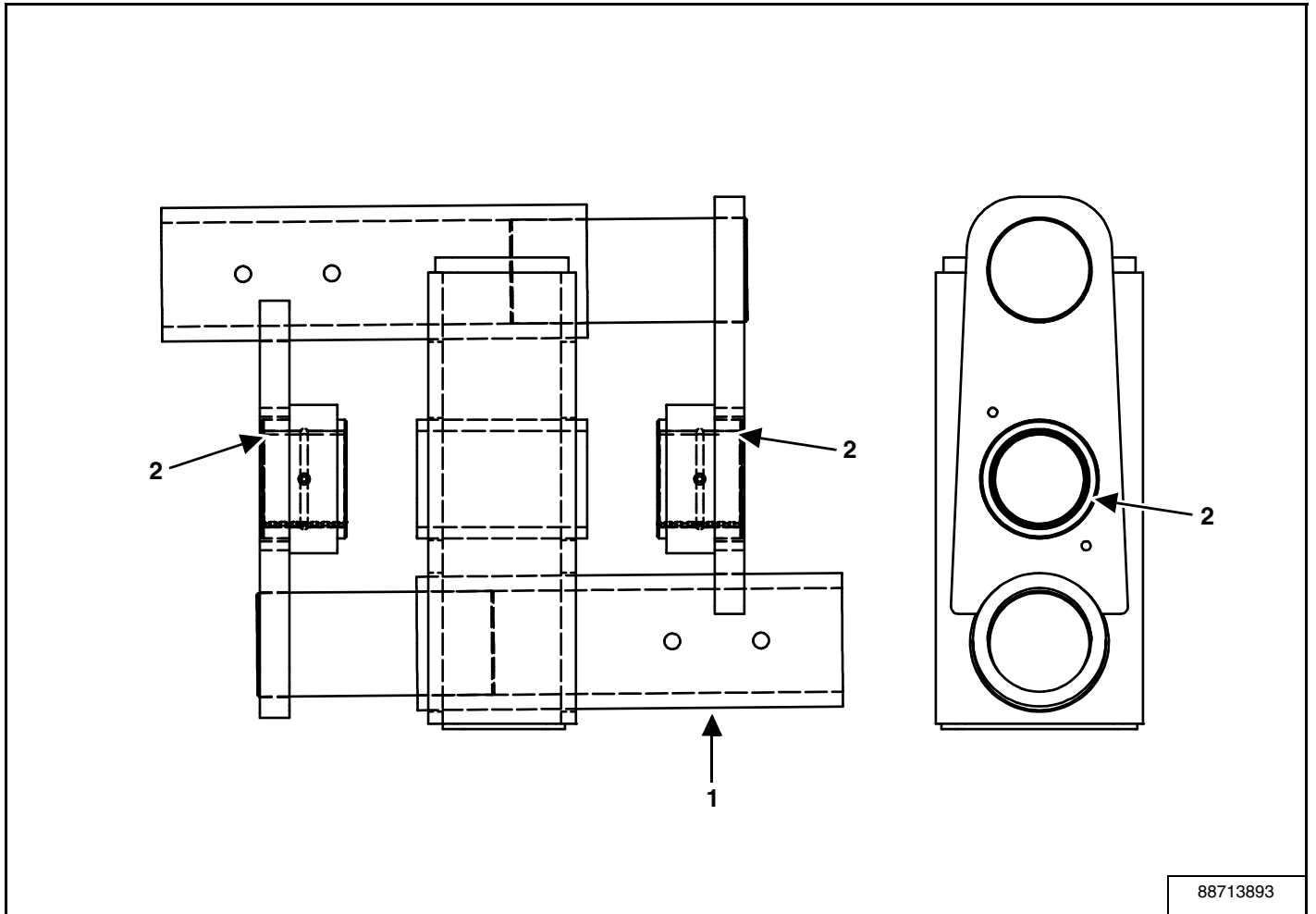

88713893

ITEM	PART NUMBER	DESCRIPTION	QTY
1	88713888	WALKING BEAM WELDMENT	1
2	88713643	BUSHING, PIVOT, WALKING BEAM	2

Rockshaft Assembly - Main Frame

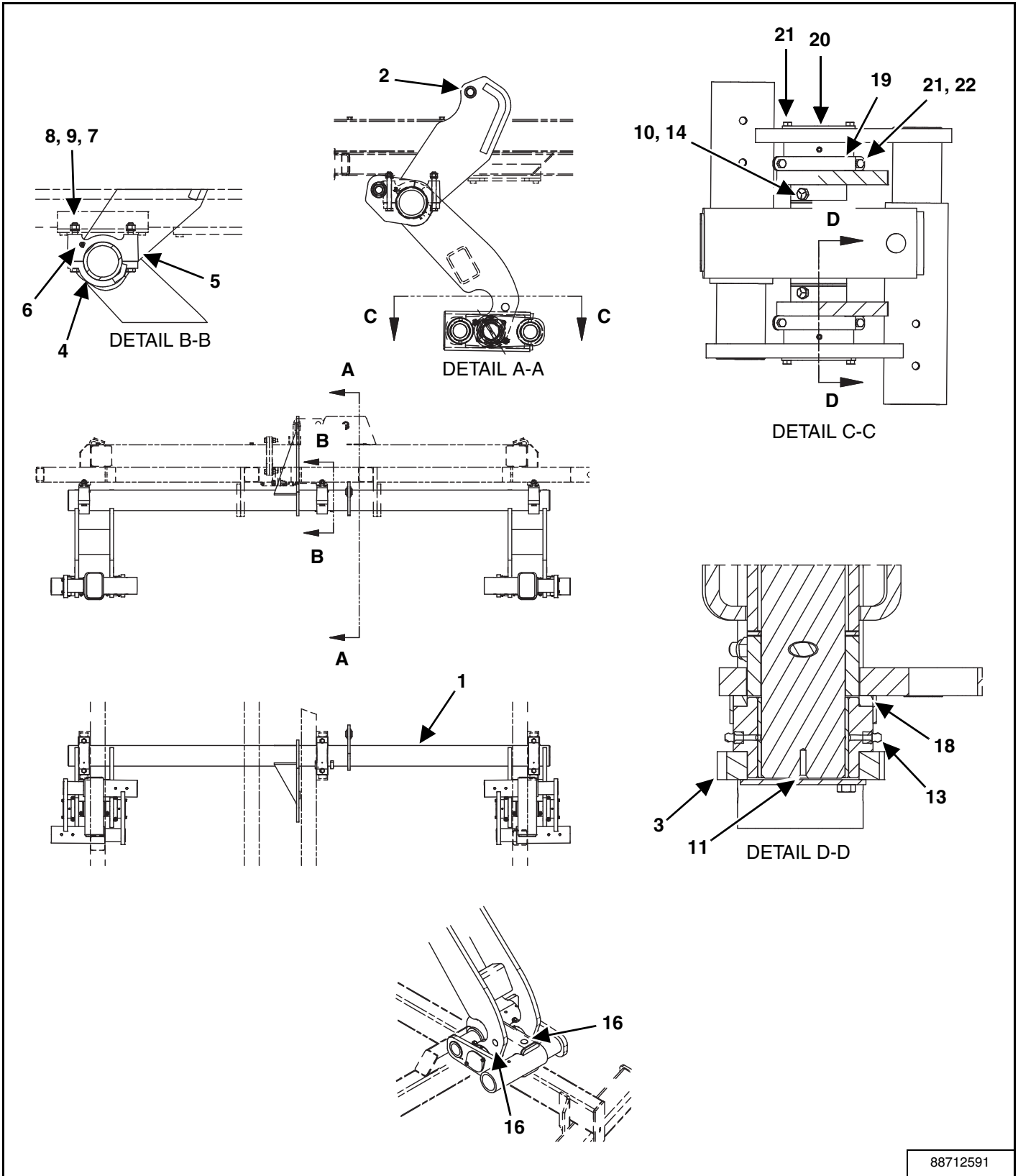

ITEM	PART NUMBER	DESCRIPTION	QTY
1	88712574	MAIN FRAME ROCKSHAFT WELDMENT	1
2	EZDR13120	SPRING BUSHING	1
3	88713893	WALKING BEAM ASSEMBLY	2
4	EZDR8601B	BOTTOM BEARING HOUSING	3
5	EZDR8601T	TOP BEARING HOUSING	3
6	EZ10GN1	GREASE ZERK, 1/4" UNF ST	3
7	EZB075065	BOLT, HEX 3/4" NC x 6-1/2" GR 5 ZNCR	6
8	EZBW075L	LOCK WASHER, 3/4" x 1-1/4" x 3/16" ZNCR	6
9	EZBN075	NUT, HEX 3/4" NC GRADE 5 ZNCR	6
10	EZBN050L	LOCK NUT, 1/2" NC HEX NYL ZNCR	4
11	88713892	PIVOT PIN, WB	2
12	88713573	THRUST WASHER, WB	4
13	80710	LUBE FITTING, 1/8" NPT	8
14	EZB050050	BOLT, 1/2" NC x 5" HEX CAP GR 5 ZNCR	4
15	86050059	STD LITHIUM GREASE	*
16	21867	GREASE DAILY DECAL	6
17	86557158	ANTI SEIZE, PER 86557157	*
18	88713905	WALKING BEAM SEAL	4
19	88713911	CLAMP, WB SEAL	8
20	88713910	WALKING BEAM SHAFT COVER	4
21	87982	BOLT, CCHH G5P 0.378" x 0.75"	16
22	EZBN037L	NUT, HEX NYL 3/8" NC	8

*As Required

Wing Frame - Super Narrow

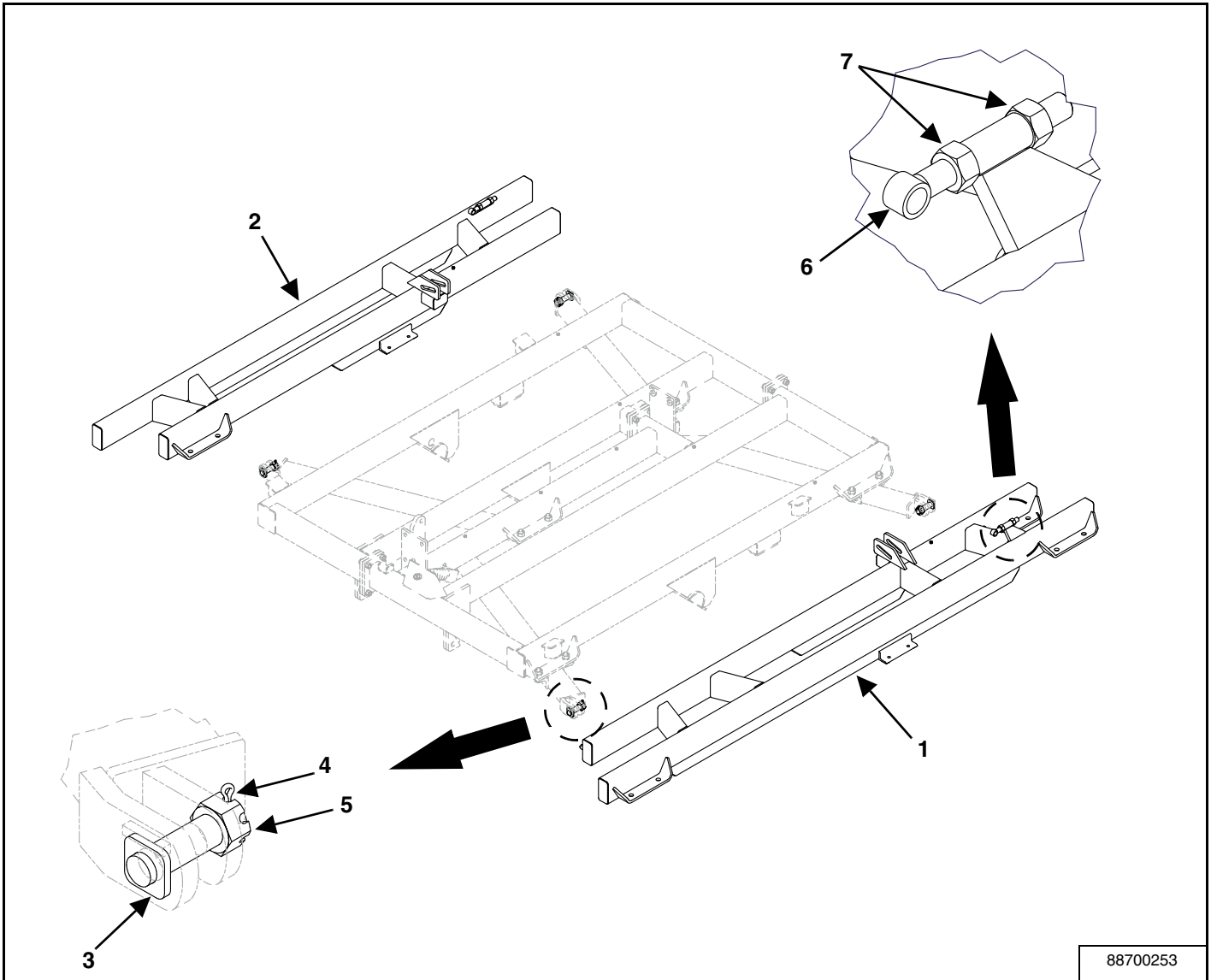

88700253

ITEM	PART NUMBER	DESCRIPTION	QTY
1	88713171	WING - WA SUPER NARROW L/H	1
2	88713177	WING - WA SUPER NARROW R/H	1
3	EZDG1309	PIN, WING HINGE 1-1/2"	4
4	EZBP31225	PIN, COTTER, 5/16" x 2-1/4"	4
5	EZDH5165	NUT, HEX SLOT, 1-1/2" NC GRADE 2	4
6	EZDFA9564	ROD-W.A. EYE BOLT	2
7	EZBN125	NUT, HEX 1-1/4" NC GRADE 2 ZNCR	4

Wing Frame - Narrow

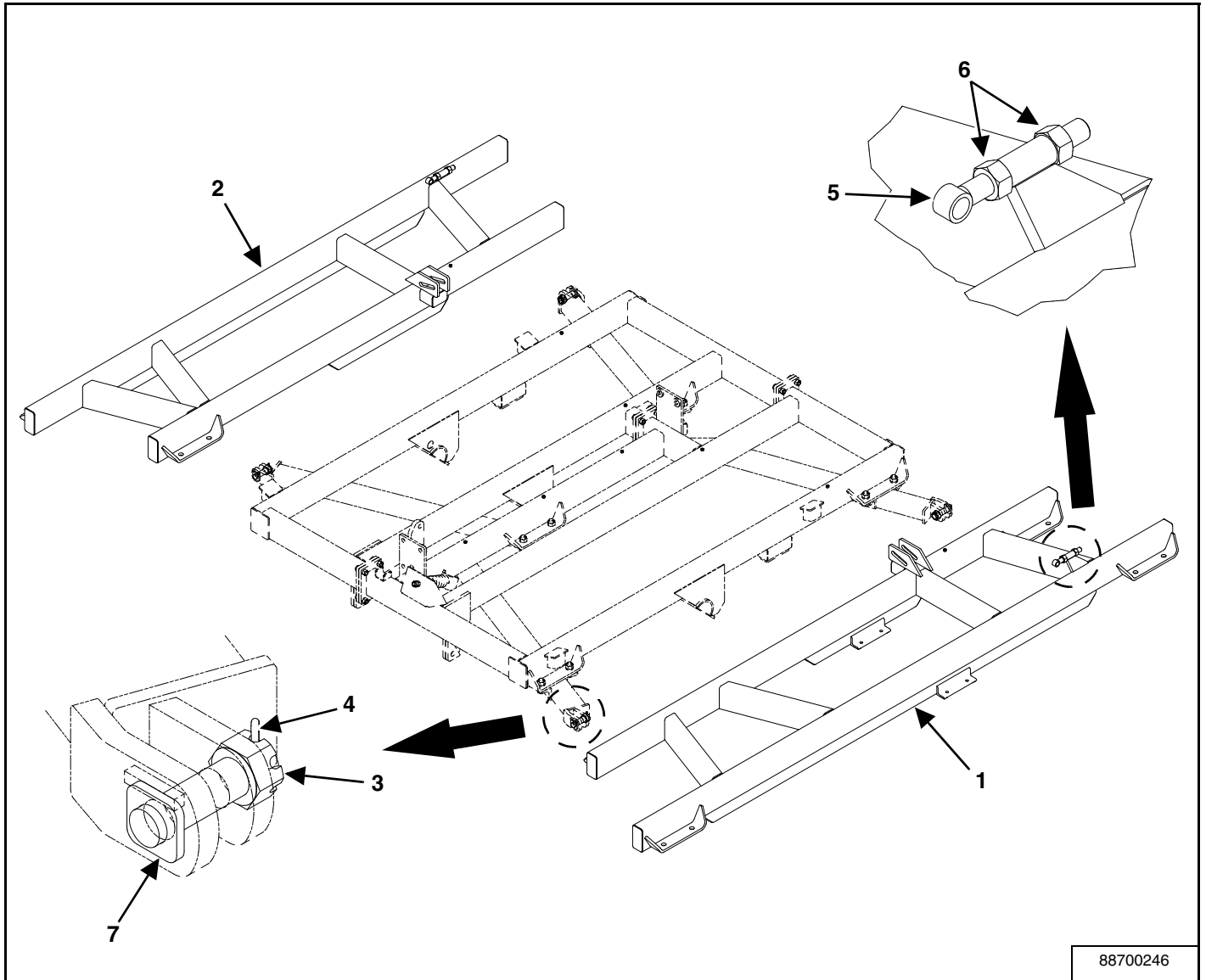

ITEM	PART NUMBER	DESCRIPTION	QTY
1	88713159	WING - WA NARROW L/H	1
2	88713166	WING - WA NARROW R/H	1
3	EZDH5165	NUT, HEX SLOT, 1-1/2" NC GRADE 2	4
4	EZBP31225	PIN, COTTER, 5/16" x 2-1/4"	4
5	EZDFA9564	ROD-W.A. EYE BOLT	2
6	EZBN125	NUT, HEX 1-1/4" NC GRADE 2 ZNCR	4
7	EZDG1309	PIN, WING HINGE 1-1/2"	4

Wing Frame - Wide

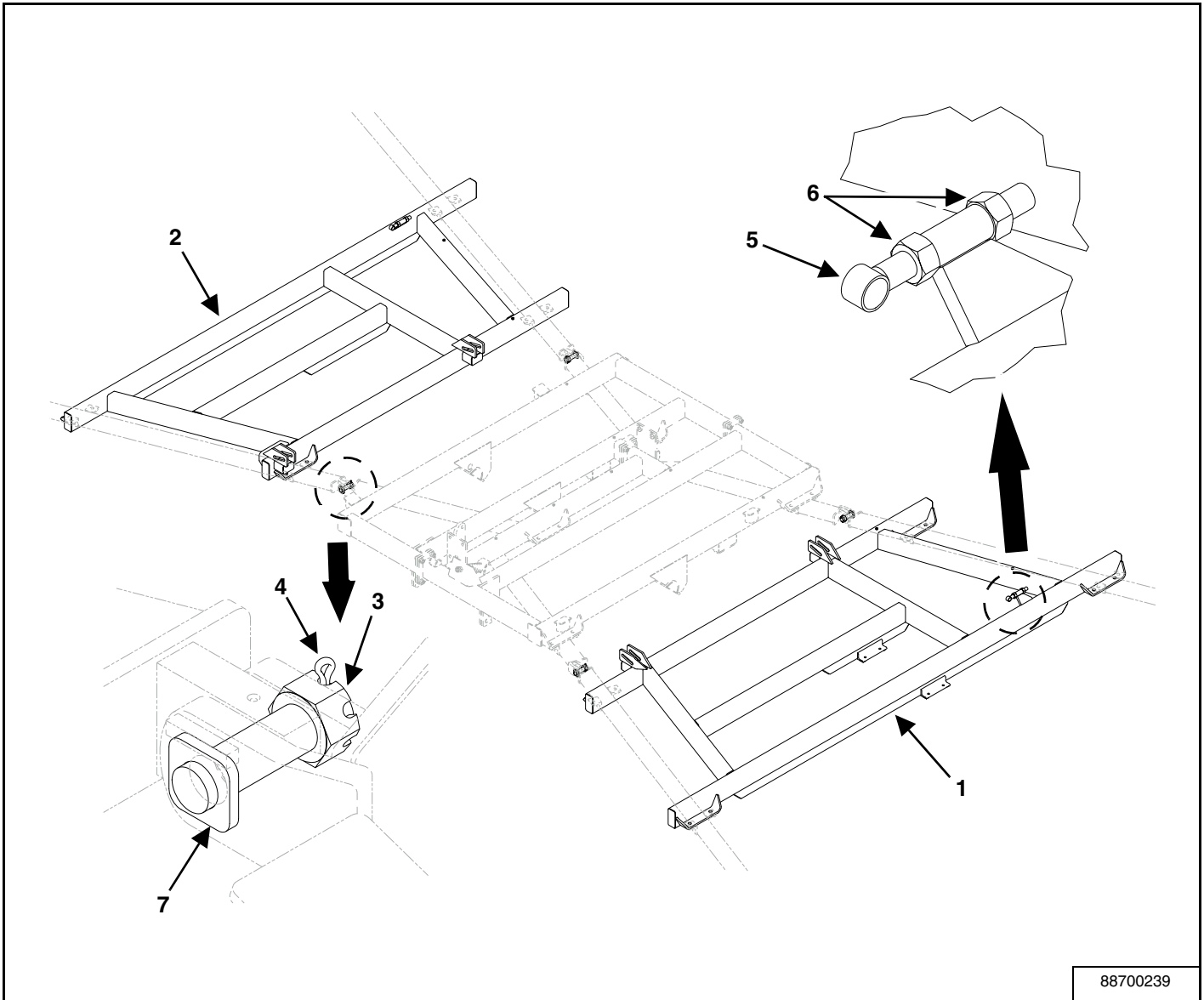

ITEM	PART NUMBER	DESCRIPTION	QTY
1	88713102	WING - WA WIDE L/H	1
2	88713103	WING - WA WIDE R/H	1
3	EZDH5165	NUT, HEX SLOT, 1-1/2" NC GRADE 2	4
4	EZBP31225	PIN, COTTER, 5/16" x 2-1/4"	4
5	EZDFA9564	ROD-W.A. EYE BOLT	2
6	EZBN125	NUT, HEX 1-1/4" NC GRADE 2 ZNCR	4
7	EZDG1309	PIN, WING HINGE 1-1/2"	4

Gang Socket

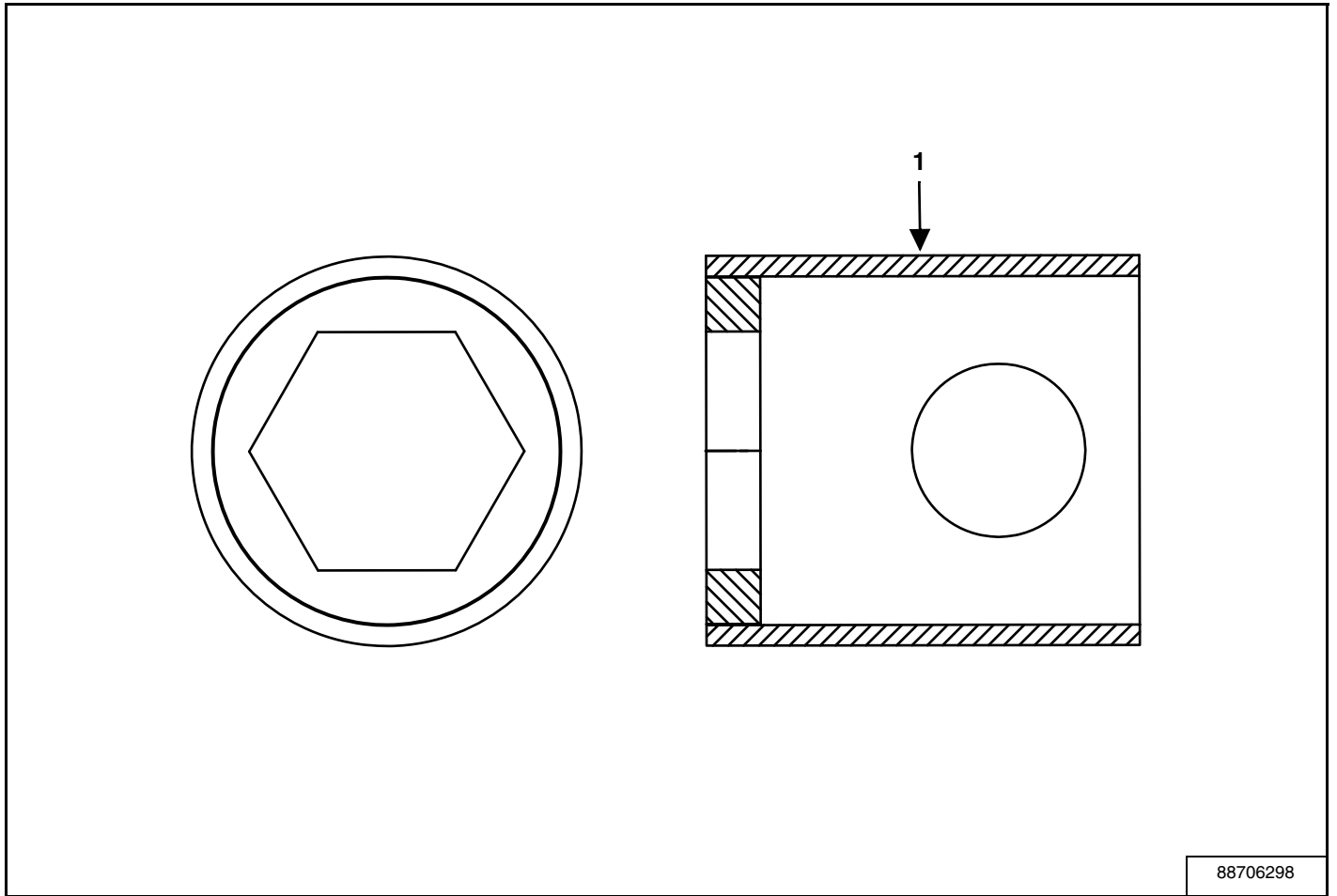

88706298

ITEM	PART NUMBER	DESCRIPTION	QTY
1	88700107	SOCKET WRENCH, W.A.	1

Wing Gang Beams 10.5 In. Spacing

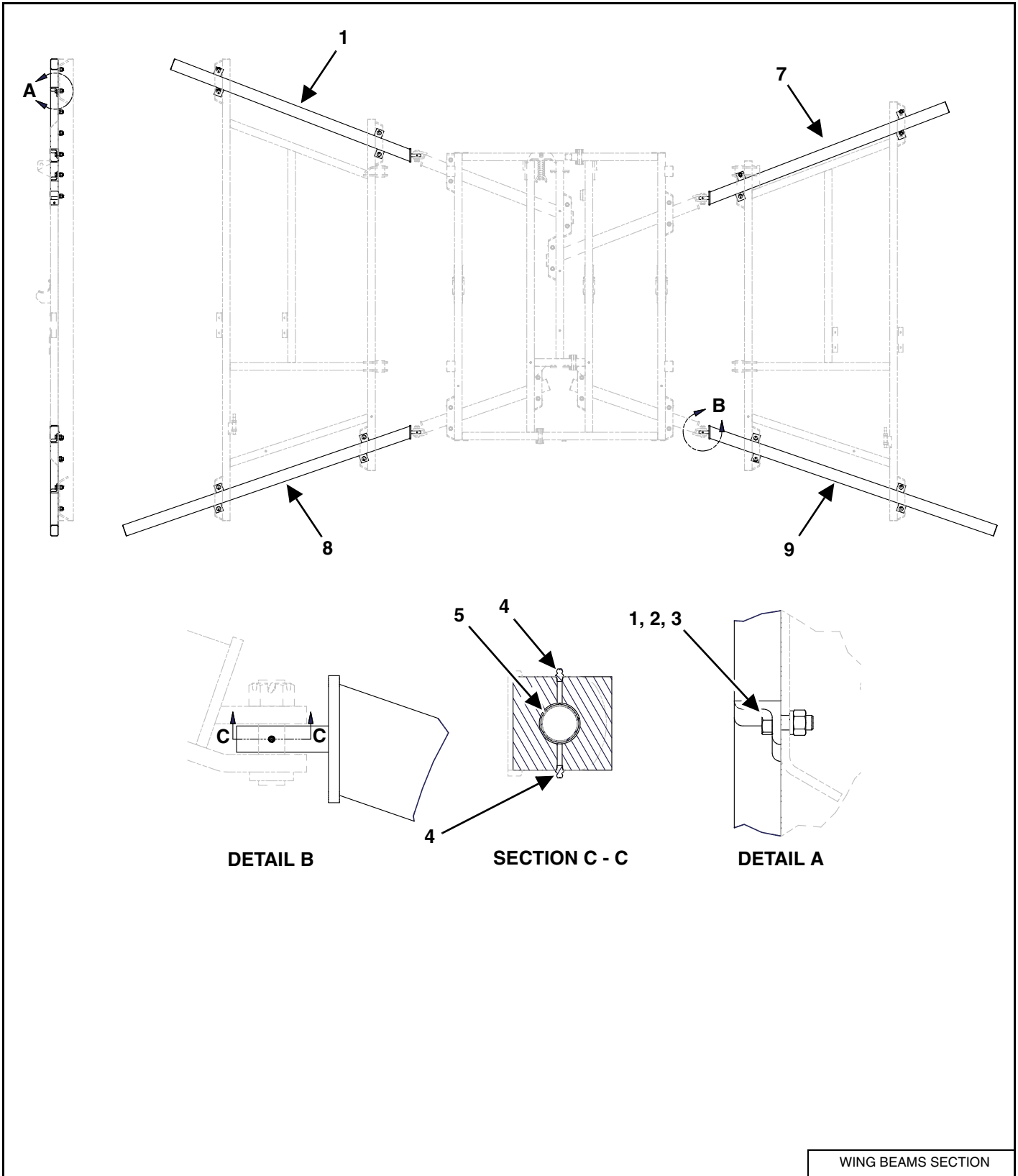

ITEM	PART NUMBER	DESCRIPTION	QTY
1	EZB125035	CHSS GR5 ZNCR 1-1/4" x 3-1/2" LG	16
2	EZBN125	NUT, 1-1/4" NC HEX GR 2 ZNCR	16
3	EZBW125L	LOCK WASHER, 1-1/4" x 1" x 5/16" ZNCR	16
4	EZ10GN1	STRAIGHT ZERK FITTING, 1/4" UNF	8
5	EZDG13286	SPRING BUSHING, W/OIL GROOVE	4
6	EZDG13144	GANG BEAM 70" - 58 BLADES	1
	EZDG13146	GANG BEAM 78" - 62 BLADES	1
	EZDG13034	GANG BEAM 91" - 66 BLADES	1
	EZDG13029	GANG BEAM 113" - 74 BLADES	1
	EZDG13036	GANG BEAM 134" - 82 BLADES	1
	EZDG13037	GANG BEAM 156" - 90 BLADES	1
7	EZDG13165	GANG BEAM 70" - 58 BLADES	1
	EZDG13166	GANG BEAM 78" - 62 BLADES	1
	EZDG13051	GANG BEAM 91" - 66 BLADES	1
	EZDG13046	GANG BEAM 113" - 74 BLADES	1
	EZDG13052	GANG BEAM 134" - 82 BLADES	1
	EZDG13053	GANG BEAM 156" - 90 BLADES	1
8	EZDG13178	GANG BEAM 90" - 58 BLADES	1
	EZDG13179	GANG BEAM 100" - 62 BLADES	1
	EZDG13066	GANG BEAM 113" - 66 BLADES	1
	EZDG13061	GANG BEAM 135" - 74 BLADES	1
	EZDG13067	GANG BEAM 156" - 82 BLADES	1
	EZDG13068	GANG BEAM 178" - 90 BLADES	1
9	EZDG13189	GANG BEAM 90" - 58 BLADES	1
	EZDG13192	GANG BEAM 100" - 62 BLADES	1
	EZDG13080	GANG BEAM 113" - 66 BLADES	1
	EZDG13076	GANG BEAM 135" - 74 BLADES	1
	EZDG13081	GANG BEAM 156" - 82 BLADES	1
	EZDG13082	GANG BEAM 178" - 90 BLADES	1

Wing Gang Beams 12 In. Spacing

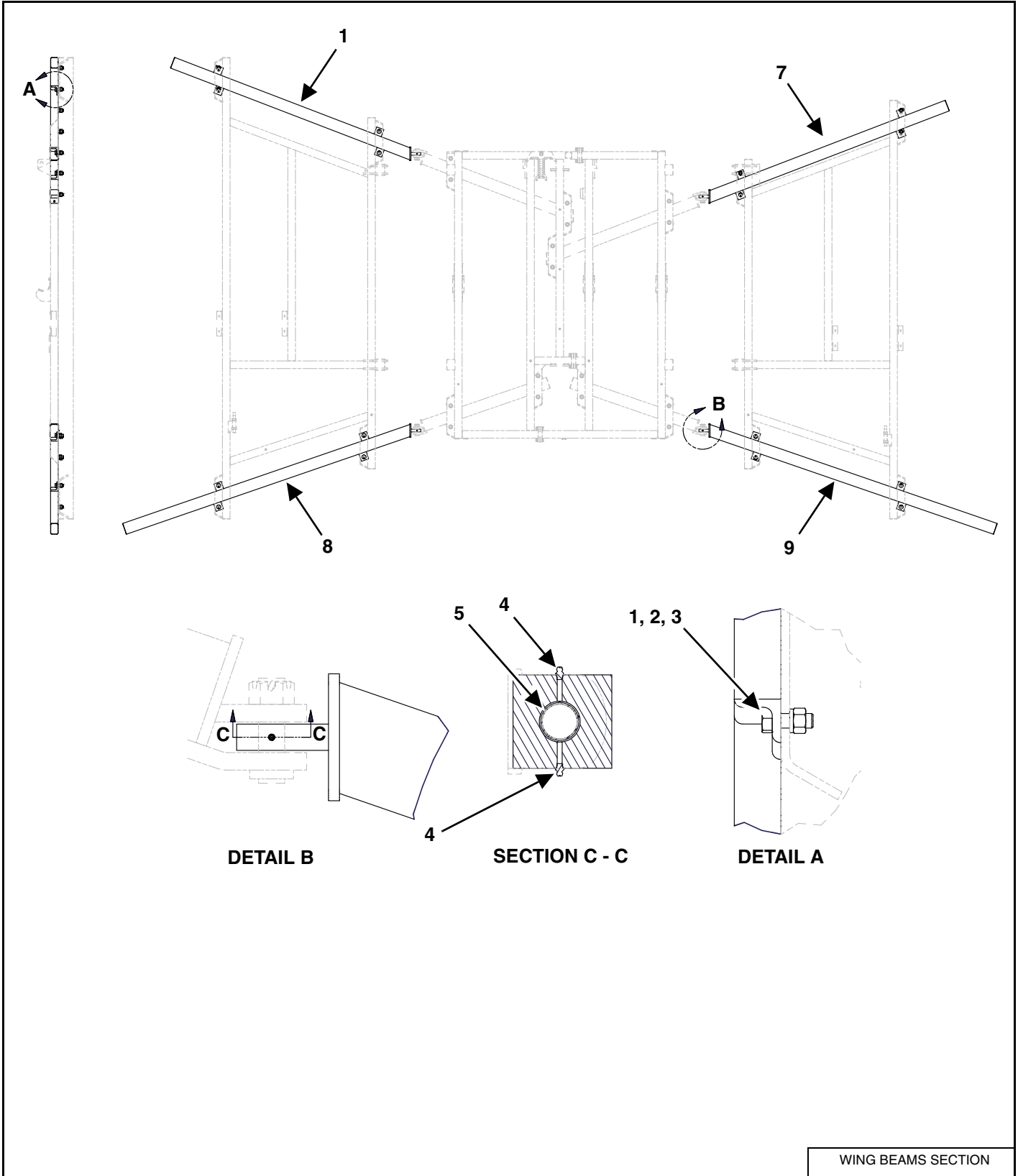

ITEM	PART NUMBER	DESCRIPTION	QTY
1	EZB125035	BOLT, 1-1/4" x 3-1/2" LG CHSS GR 5 ZNCR	16
2	EZBN125	NUT,X 1-1/4" NC HE GR 2 ZNCR	16
3	EZBW125L	LOCK WASHER, 1-1/4" x 1" x 5/16" ZNCR	16
4	EZ10GN1	STARIGHT ZERK FITTING, 1/4" UNF	8
5	EZDG13286	SPRING BUSHING, W/OIL GROOVE	4
6	EZDG13147	GANG BEAM 68" - 50 BLADES	1
	EZDG13148	GANG BEAM 72" - 54 BLADES	1
	EZDG13028	GANG BEAM 85" - 58 BLADES	1
	EZDG13149	GANG BEAM 98" - 62 BLADES	1
	EZDG13040	GANG BEAM 110" - 66 BLADES	1
	EZDG13041	GANG BEAM 135" - 74 BLADES	1
	EZDG13042	GANG BEAM 148" -78 BLADES	1
7	EZDG13167	GANG BEAM 68" - 50 BLADES	1
	EZDG13168	GANG BEAM 72" - 54 BLADES	1
	EZDG13045	GANG BEAM 85" - 58 BLADES	1
	EZDG13169	GANG BEAM 98" - 62 BLADES	1
	EZDG13055	GANG BEAM 110" - 66 BLADES	1
	EZDG13056	GANG BEAM 135" - 74 BLADES	1
	EZDG13057	GANG BEAM 148" - 78 BLADES	1
8	EZDG13181	GANG BEAM 85" - 50 BLADES	1
	EZDG13182	GANG BEAM 97" - 54 BLADES	1
	EZDG13071	GANG BEAM 110" - 58 BLADES	1
	EZDG13183	GANG BEAM 123" - 62 BLADES	1
	EZDG13061	GANG BEAM 135" - 66 BLADES	1
	EZDG13072	GANG BEAM 160" - 74 BLADES	1
	EZDG13063	GANG BEAM 173" - 78 BLADES	1
9	EZDG13193	GANG BEAM 85" - 50 BLADES	1
	EZDG13194	GANG BEAM 97" - 54 BLADES	1
	EZDG13085	GANG BEAM 110" - 58 BLADES	1
	EZDG13195	GANG BEAM 123" - 62 BLADES	1
	EZDG13086	GANG BEAM 135" - 66 BLADES	1
	EZDG13087	GANG BEAM 160" - 74 BLADES	1
	EZDG13078	GANG BEAM 173" - 78 BLADES	1

Wing Beam 26" x 0.313" Blades - 10.5" Spacing

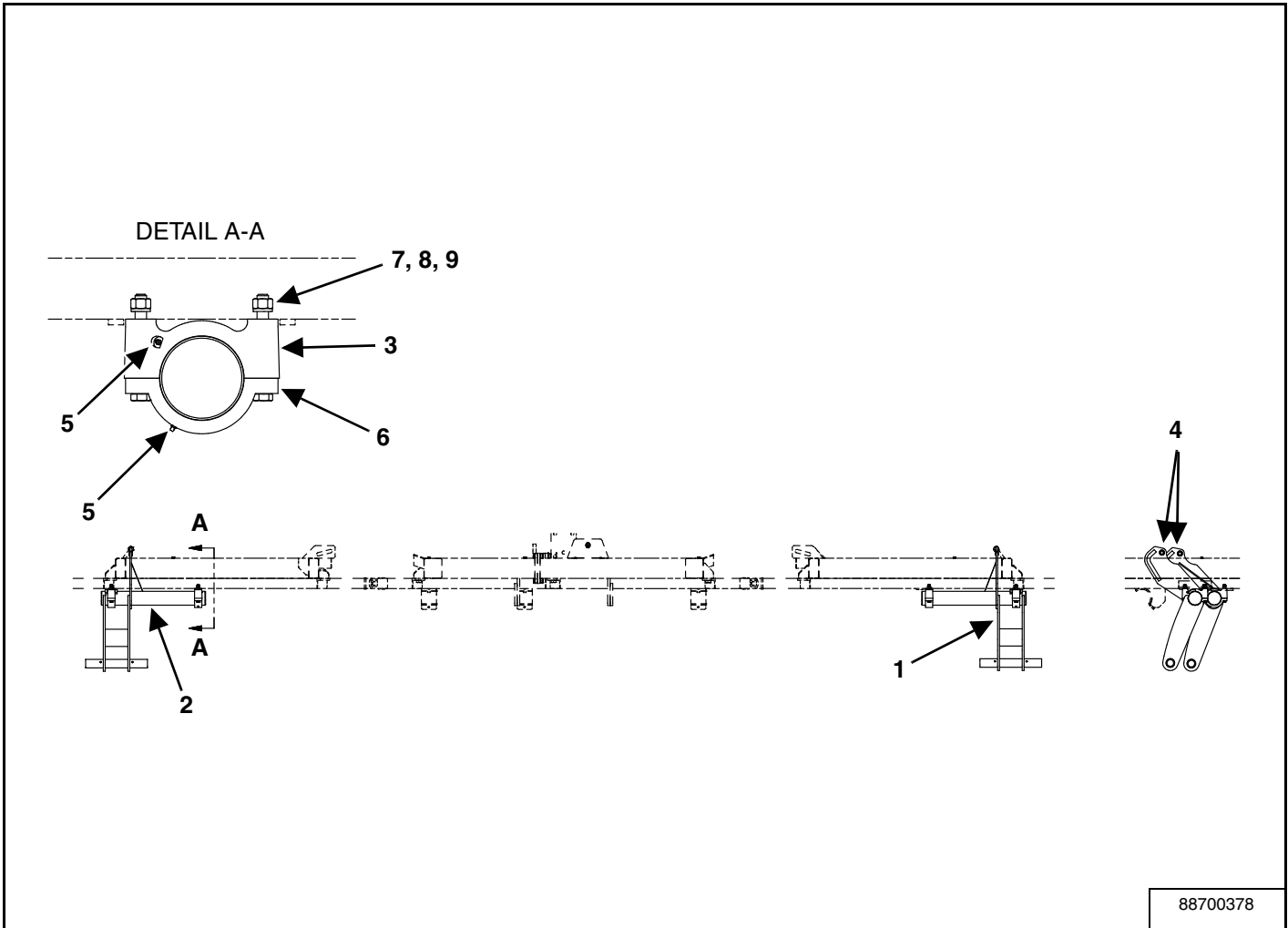

ITEM	PART NUMBER	DESCRIPTION	QTY
1	EZDG74	PLAIN BLADE, 26" x 0.313"	*
	EZDG75	NOTCHED BLADE, 26" x 0.313"	*
2	EZDG64	PLAIN BLADE, 22" x 1/4"	*
3	EZDG133	PLAIN BLADE, 18" x 3/16"	*

*As Required

Wing Beam 26 In. x 0.375 In. Blades - 10.5 In. Spacing

ITEM	PART NUMBER	DESCRIPTION	QTY
1	EZDG107	PLAIN BLADE, 26" x 0.375"	*
	EZDG87	NOTCHED BLADE, 26" x 0.375"	*
2	EZDG64	PLAIN BLADE, 22" x 1/4"	*
3	EZDG133	PLAIN BLADE, 18" x 3/16"	*
*As Required			

Wing Beam 28 In. x 0.375 In. Blades - 10.5 In. Spacing & 12 In. Spacing

ITEM	PART NUMBER	DESCRIPTION	QTY
1	EZDG130	PLAIN BLADE, 28" x 0.375"	*
	EZDG20051	NOTCHED BLADE, 28" x 0.375"	*
2	EZDG76	PLAIN BLADE, 24" x 0.276"	*
3	EZDG149	PLAIN BLADE, 20" x 0.236"	*
*As Required			

Wing Beam 30 In. x 0.375 In. Blades - 12 In. Spacing

ITEM	PART NUMBER	DESCRIPTION	QTY
1	EZDG180	PLAIN BLADE, 30" x 0.375"	*
	EZDG181	NOTCHED BLADE, 30" x 0.375"	*
2	EZDG107	PLAIN BLADE, 26" x 0.375"	*
3	EZDG64	PLAIN BLADE, 22" x 1/4"	*
*As Required			

Rockshaft Assembly - Wing Frame

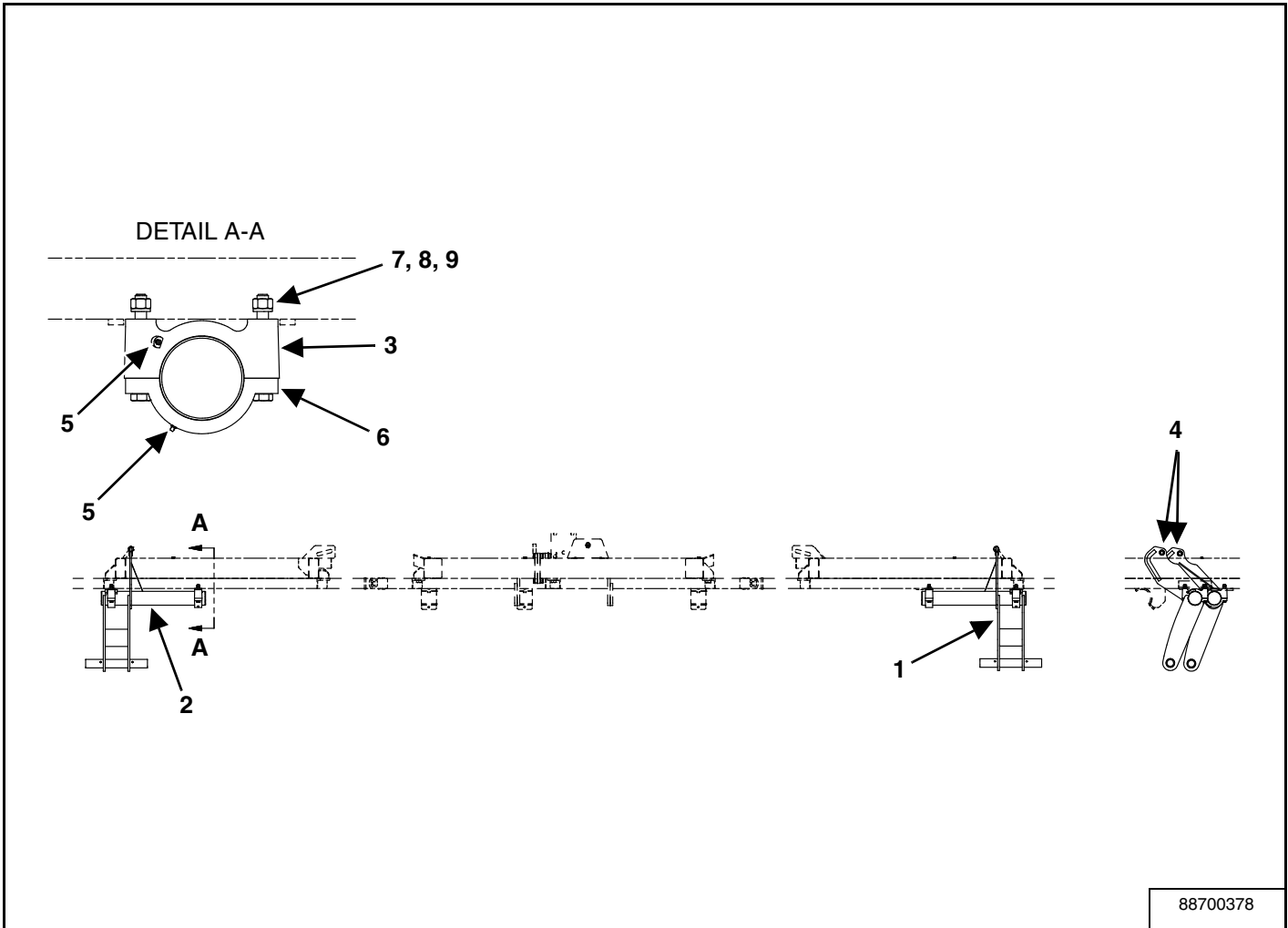

88700378

ITEM	PART NUMBER	DESCRIPTION	QTY
1	88712609	L/H ROCKSHAFT WING WELDMENT	1
2	88712610	R/H ROCKSHAFT WING WELDMENT	1
3	EZDR8601T	TOP BEARING HOUSING	4
4	EZDR13120	SPRING BUSHING	2
5	EZ10GN1	STRAIGHT ZERK FITTING, 1/4" UNF	8
6	EZDR8601B	BOTTOM BEARING HOUSING	4
7	EZB075065	BOLT, 3/4" NC x 6-1/2" HEX GRADE 5 ZNCR	8
8	EZBW075L	LOCK WASHER, 3/4" x 1-1/4" x 3/16" ZNCR	8
9	EZBN075	NUT, 3/4" NC HEX GRADE 5 ZNCR	8

Warning Light Assembly

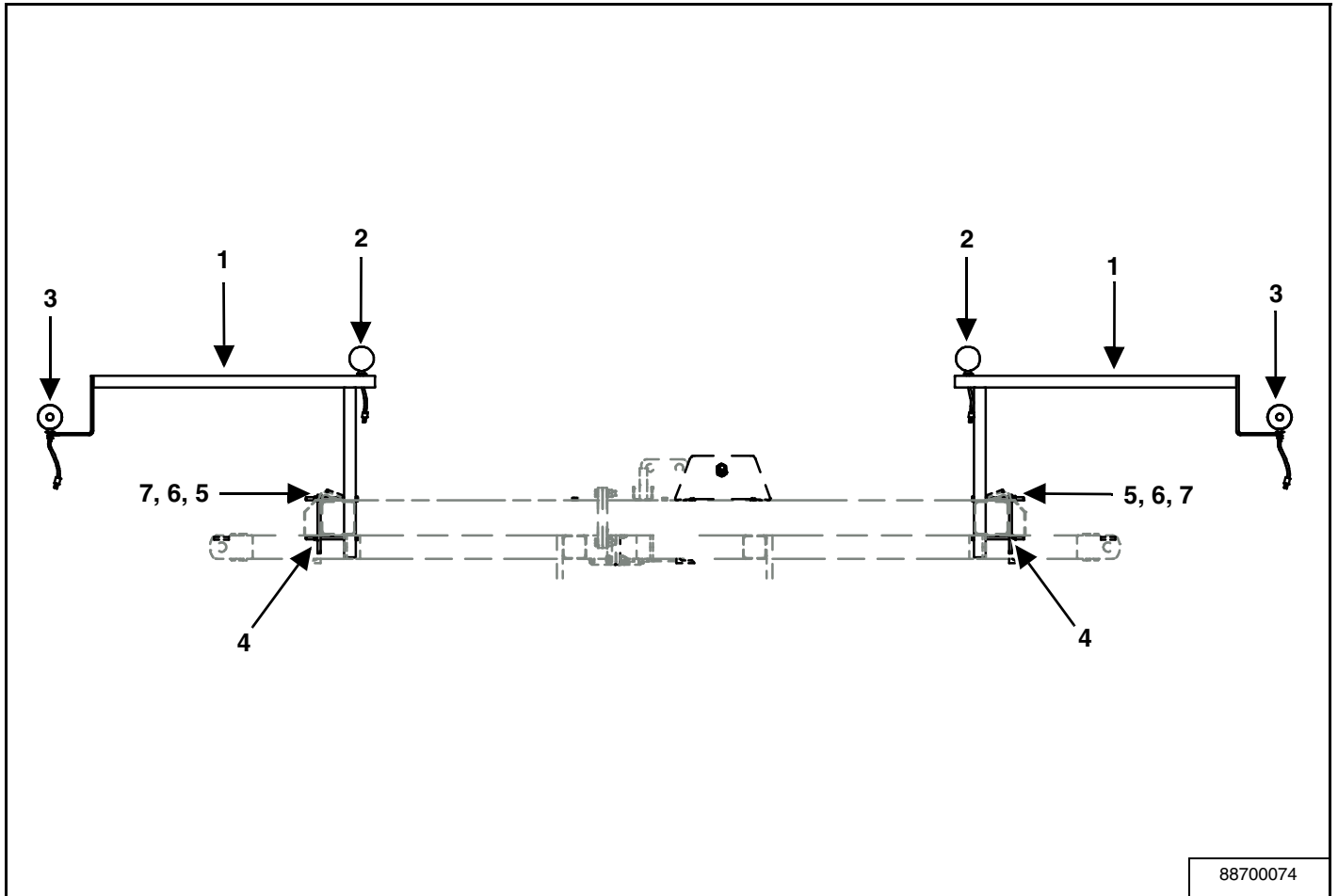

88700074

ITEM	PART NUMBER	DESCRIPTION	QTY
1	EZLK6252	BRACKET-W.A. LIGHT KIT	2
2	EZLK6425	RED LAMP, W/3 PIN PLUG	2
3	EZLK6426	AMBER LAMP, W/2 PIN PLUG	2
4	EZLK6404	PLATE, BACKING, LIGHT KIT	2
5	EZB050085	BOLT, 1/2" NC x 8-1/2" HEX	4
6	EZBN050	NUT, 1/2" NC HEX ZNCR	4
7	EZBW050L	LOCK WASHER, 1/2" x 7/8" x 1/8" ZNCR	4
NS	EZLK6427	HARNESS, WARNING LIGHTS 55 FT.	1

ITEM	PART NUMBER	DESCRIPTION	QTY
1	EZDG5293	STANDARD SCRAPER, FRONT L.H. / REAR R.H.	*
	EZDG5292	FRONT R.H. / REAR L.H. SCRAPER (Not Shown)	*
2	EZDS61	6 BLADE SCRAPER BAR, 61" (1663.7 mm) (90° Scraper)	*
	EZDS65	6 BLADE SCRAPER BAR, 65-1/2" (1663.7 mm)	*
	EZDS66	6 BLADE SCRAPER BAR, 66" (1676.4 mm) (Rear Main Frame)	*
	EZDS76	7 BLADE SCRAPER BAR, 76-1/2" (1943.1 mm)	*
	EZDS82	8 BLADE SCRAPER BAR, 82-1/2" (2095.5 mm) (90° Scraper)	*
	EZDS87	8 BLADE SCRAPER BAR, 87" (2209.8 mm)	*
	EZDS93	9 BLADE SCRAPER BAR, 93" (2362.2 mm) (90° Scraper)	*
	EZDS97	9 BLADE SCRAPER BAR, 97-1/2" (2476.5 mm)	*
	EZDS107	10 BLADE SCRAPER BAR, 107-1/2" (2730.5 mm) (90° Scraper)	*
	EZDS114	11 BLADE SCRAPER BAR, 114-1/2" (2908.3 mm) (90° Scraper)	*
	EZDS118	11 BLADE SCRAPER BAR, 118-1/2" (3009.9 mm)	*
	EZDS130	12 BLADE SCRAPER BAR, 130-1/2" (3314.7 mm)	*
3	EZDG5308	U-BOLT, 1/2" (12.7 mm) x 2" (50.8 mm)	*
4	EZDG5309	U-BOLT, 5/8" (15.9 mm) x 2" (50.8 mm)	*
5	EZBN050	NUT, 1/2" (12.7 mm) N.C. HEX	*
6	EZBN062	NUT, 5/8" (15.9 mm) N.C. HEX	*
7	EZBW050L	LOCK WASHER, 1/2" (12.7 mm)	*
8	EZBW062L	LOCK WASHER, 5/8" (15.9 mm)	*
9	EZDG5297	STANDARD 90° SCRAPER, FRONT L.H. & REAR R.H.	*
	EZDG5298	STANDARD 90° SCRAPER, FRONT R.H. & REAR L.H.	*
10	EZDG5296	SCRAPER BAR MOUNT PLATE	*
11	EZDGI3145	U-BOLT, 3/4" (19 mm) x 6-7/8" (174.5 mm)	*
12	EZBW075L	LOCK WASHER, 3/4" (19 mm)	*
13	EZBNO75	NUT, 3/4" (19 mm) N.C. HEX	*
14	EZDG5303	OFFSET SCRAPER MOUNT	*
15	EZDG13218	HEAVY DUTY 90° SCRAPER, FRONT R.H. & REAR L.H.	*
	EZDG13217	HEAVY DUTY 90° SCRAPER, FRONT L.H. & REAR R.H.	*
16	EZDG13216	HEAVY DUTY SCRAPER, FRONT R.H. & REAR L.H.	*
	EZDG13215	HEAVY DUTY SCRAPER, FRONT L.H. & REAR R.H.	*
17	EZDG7195	WIDE PAN 90° HEAVY DUTY SCRAPER HOLDER	*
18	EZDG7194	WIDE PAN HEAVY DUTY SCRAPER HOLDER	*
19	EZBO50012C	CARRIAGE BOLT, 1/2" x 1-1/4" (12.7 mm x 32 mm) N.C.	*
20	EZDG7190	WIDE PAN SCRAPER	*
* As Required			

Gang Assembly, T2-215 Bearings, 10.5 In. Spacing, 26 In. Blades

MOUNTING BOLT, OPTIONAL WEAR PLATE

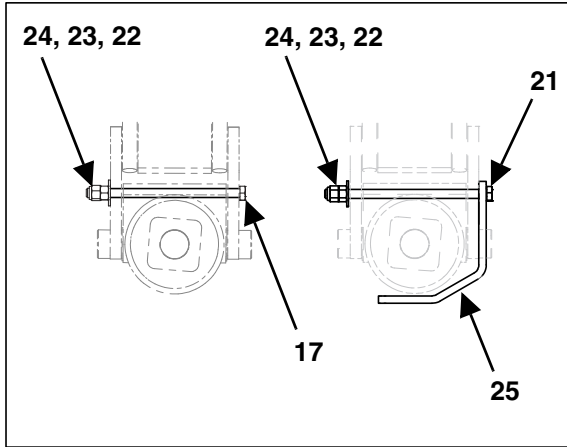

INTERLOCKING BEARINGS

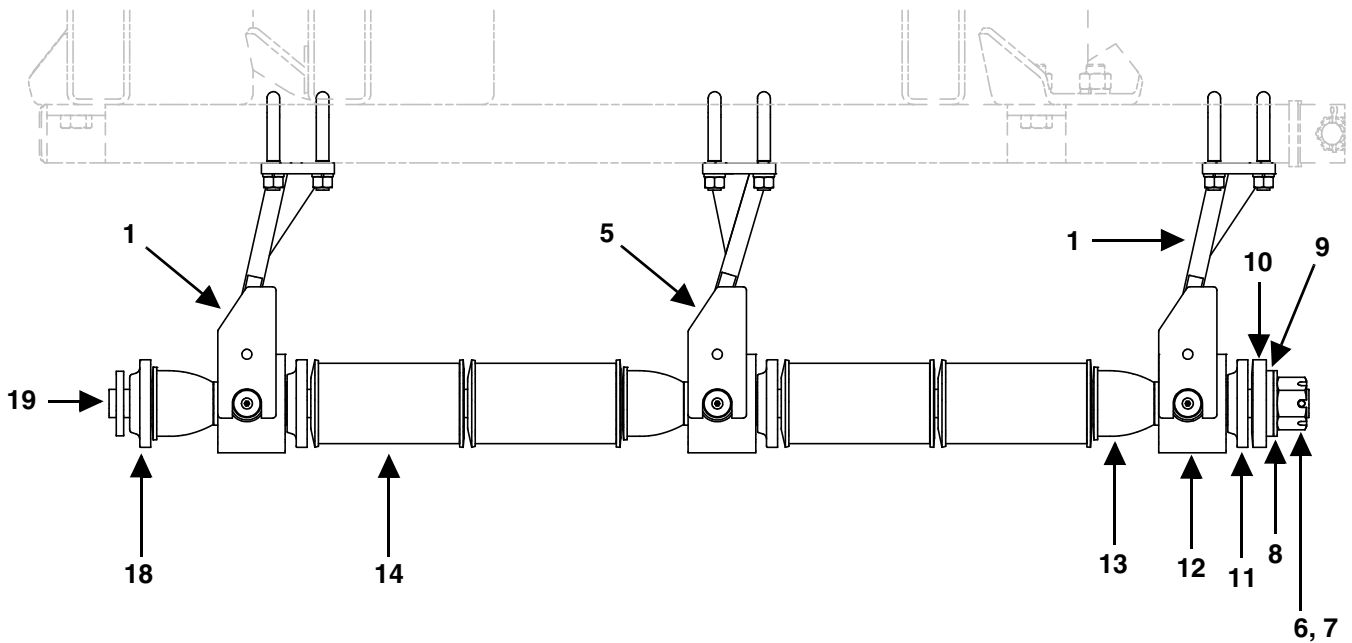
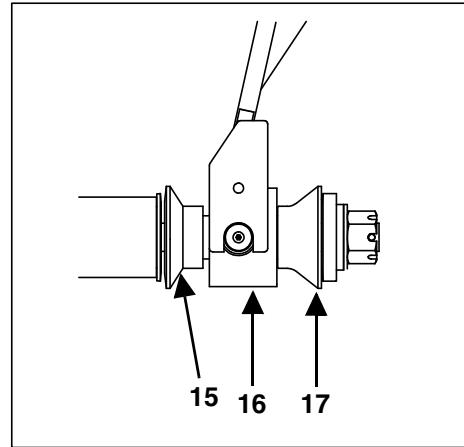

T2-215 STANDARD & INTERLOCKING BEARINGS, 10.5

ITEM	PART NUMBER	DESCRIPTION	QTY
1	EZDGA13163	2" HANGER BRACKET, W.A. O/S	*
2	EZDG5379	U-BOLT, 7/8" x 7"	*
3	EZBW087L	LOCK WASHER, 7/8" x 1-1/2" x 1/4" ZNCR	*
4	EZBN087	NUT, 7/8" HEX GR 5 ZNCR	*
5	EZDGA13162	STANDARD HANGER BRACKET, W.A.	*
6	EZDG82	SLOT NUT, 2" NC HEX GR 5 ZNCR	*
7	EZDG10310	PIN-LOCK DISC GANG	*
8	EZDG89	WASHER / SHIM	*
9	EZDG88	WASHER / SHIM	*
10	EZDG13184	WASHER, 6" x 2" x 1" HD	*
11	EZDGA10563	SHORT HALF SPOOL WASHER	*
12	EZDGB9900	BEARING-ASSY HSG DISC GANG	*
13	EZDGA103	HALF SPOOL, 4.5" x 4-3/16" W.A	*
14	EZDGA101	SPOOL-W.A. FULL 10.5" SPACING	*
15	EZDG9917	SPOOLS - LG1/2 PRESS ON 10.5" INTERLOCKING	*
16	EZDGB9940	BEARING-ASSY HSG DISC GANG INTERLOCKING	*
17	EZDG9919	SHORT HALF SPOOL 10.5" - 12" INTERLOCKING	*
18	EZDGA5370	PLATE-END DISC GANG	*
19	EZDGA76	BOLT, 61" - 6 BLADE GANG	*
	EZDGA77	BOLT, 71-1/2" - 7 BLADE GANG	*
	EZDGA78	BOLT, 82-1/4" - 8 BLADE GANG	*
	EZDGA79	BOLT, 93" - 9 BLADE GANG	*
	EZDGA80	BOLT, 104" - 10 BLADE GANG	*
	EZDGA81	BOLT, 114-3/4" - 11 BLADE GANG	*
	EZDGA82	BOLT, 125-3/4" - 12 BLADE GANG	*
	EZDGA83	BOLT, 136-1/2" - 13 BLADE GANG	*
20	88713493	BOLT, 5/8" NC x 10.5" HEX CAP GR 5 ZNCR - LESS WEAR GUARD	*
21	EZB062110	BOLT, 5/8" NC x 11" HEX CAP GR 5 ZNCR - WITH WEAR GUARD	*
22	EZBN062L	LOCK NUT, 5/8" NC NYLON	*
23	EZBN062	NUT, 5/8" GR 5 P	*
24	EZBW17506812F	FLAT WASHER, 11/16" ZNCR	*
25	EZDG10590	WEAR GUARD	*

*As Required

Gang Assembly, T2-215 Interlocking Bearings, 10.5 In. Spacing, 28 In. Blades, Keyed

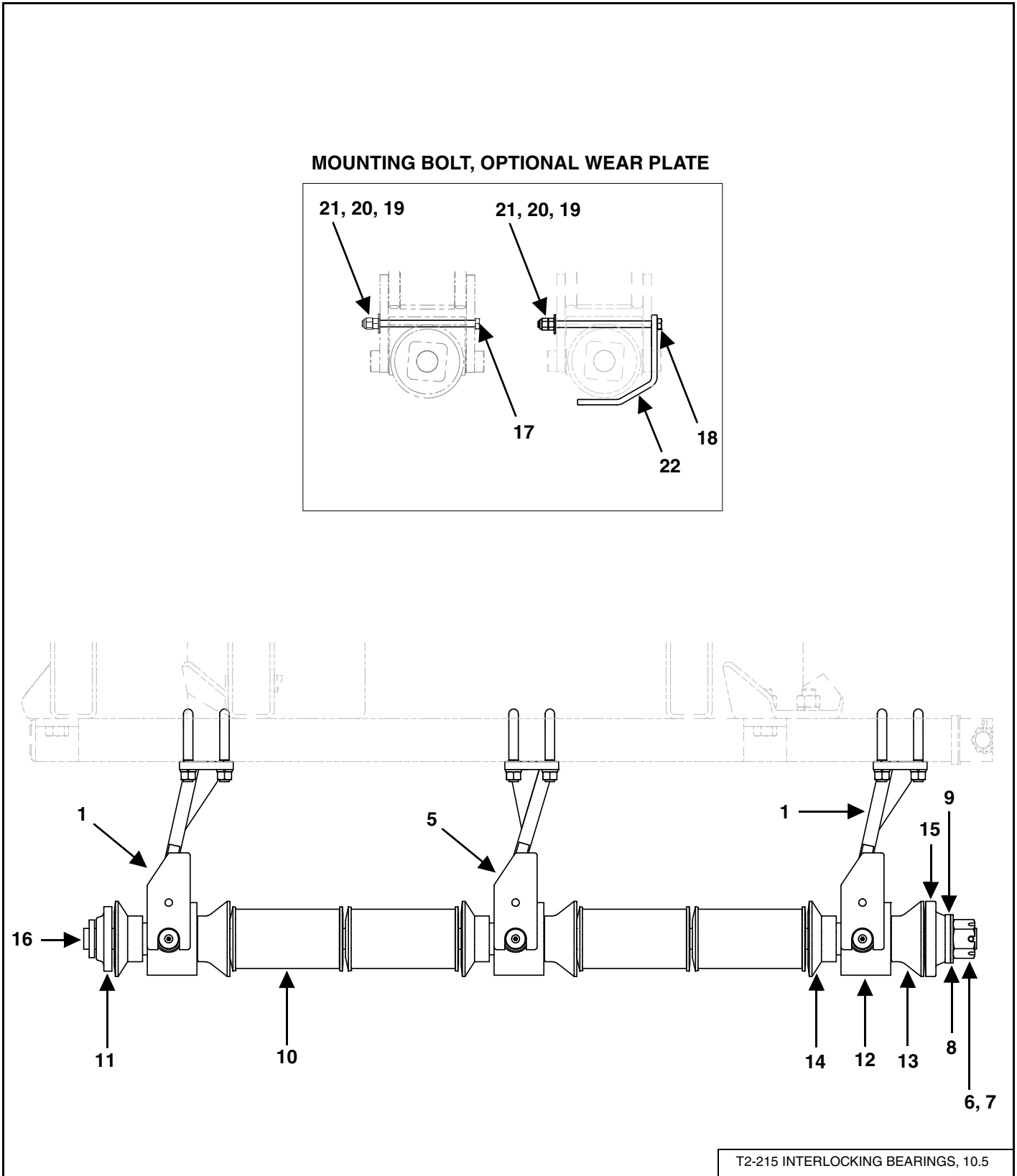

ITEM	PART NUMBER	DESCRIPTION	QTY
1	EZDGA13163	2" HANGER BRACKET, W.A. O/S	*
2	EZDG5379	U-BOLT 7/8" x 7"	*
3	EZBW087L	LOCK WASHER, 7/8" x 1-1/2" x 1/4" ZNCR	*
4	EZBN087	NUT, 7/8" HEX GR 5 ZNCR	*
5	EZDGA13162	STANDARD HANGER BRACKET, W.A.	*
6	EZDG82	NUT, 2" NC HEX SLOT GR5 ZNCR	*
7	EZDG10310	PIN-LOCK DISC GANG	*
8	EZDG89	WASHER / SHIM	*
9	EZDG88	WASHER / SHIM	*
10	EZDGA101	SPOOL-W.A. FULL 10-1/2" SPACING	*
11	EZDGA5370	PLATE-END DISC GANG	*
12	EZDGB9940	BEARING-ASSY HSG DISC GANG	*
13	EZDG9919	SHORT HALF SPOOL 10-1/2" - 12"	*
14	EZDG9917	SPOOLS - LG1/2 PRESS ON 10-1/2" SP	*
15	EZDG13180	WASHER- KEYED 7" x 2"	*
16	EZDGA226	BOLT, 61-3/4" - 6 BLADE GANG KEYED	*
	EZDGA227	BOLT, 72-1/4" - 7 BLADE GANG KEYED	*
	EZDGA228	BOLT, 83" - 8 BLADE GANG KEYED	*
	EZDGA229	BOLT, 93-3/4" - 9 BLADE GANG KEYED	*
	EZDGA230	BOLT, 104-3/4" - 10 BLADE GANG KEYED	*
	EZDGA231	BOLT, 115-1/2" - 11 BLADE GANG KEYED	*
	88713418	BOLT, 126-1/2" - 12 BLADE GANG KEYED	*
	88713419	BOLT, 137-1/4" - 13 BLADE GANG KEYED	*
17	88713493	BOLT, 5/8" NC x 10-1/2" HEX CAP GR5 ZNCR - LESS WEAR GUARD	*
18	EZB062110	BOLT, 5/8" NC x 11" HEX CAP GR 5 ZNCR - WITH WEAR GUARD	*
19	EZBN062L	LOCK NUT, 5/8" NC NYLON	*
20	EZBN062	NUT, 5/8" GR 5 P	*
21	EZBW17506812F	FLAT WASHER, 11/16" ZNCR	*
22	EZDG10590	WEAR GUARD	*

*As Required

Gang Assembly, T2-215 Interlocking Bearings, 12 In. Spacing, 28 In. Blades, Keyed

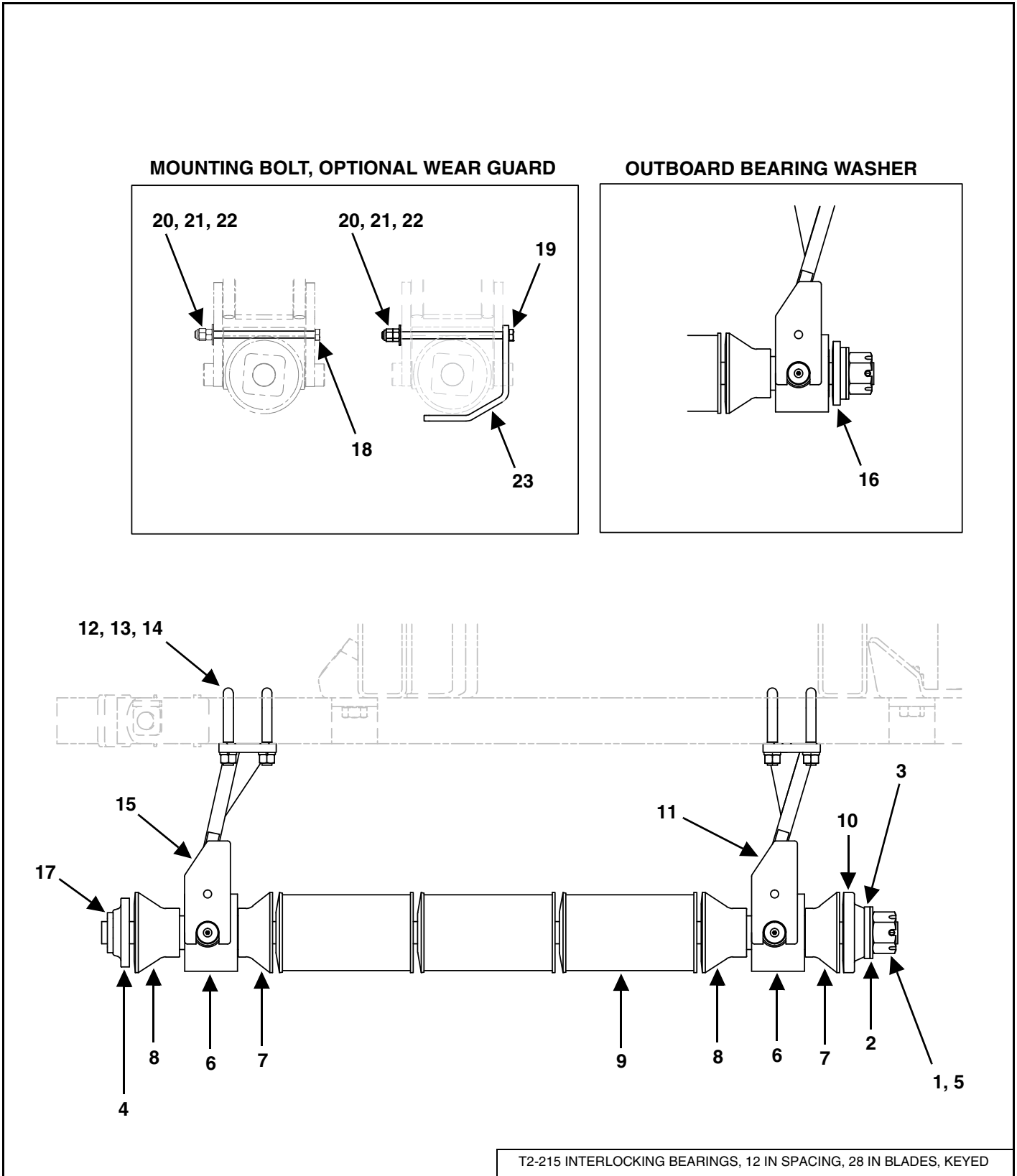

ITEM	PART NUMBER	DESCRIPTION	QTY
1	EZDG82	NUT, 2" NC HEX SLOT GR 5 ZNCR	*
2	EZDG89	WASHER / SHIM	*
3	EZDG88	WASHER / SHIM	*
4	EZDGA5370	DISC GANG END PLATE	*
5	EZDG10310	DISC GANG PIN-LOCK	*
6	EZDGB9940	BEARING-ASSY HSG DISC GANG	*
7	EZDG9919	SHORT HALF SPOOL 10-1/2" - 12"	*
8	EZDG9918	LONG HALF SPOOL 12" SPACING	*
9	EZDGA11081	SPOOL-W.A. FULL 12" SPACING	*
10	EZDG13180	KEYED WASHER, 7" x 2"	*
11	EZDGA13162	STANDARD HANGER BRACKET, W.A.	*
12	EZDG5379	U-BOLT, 7/8" x 7"	*
13	EZBW087L	LOCK WASHER, 7/8" x 1-1/2" x 1/4" ZNCR	*
14	EZBN087	NUT, 7/8" HEX GR 5 ZNCR	*
15	EZDGA13163	2" HANGER BRACKET, W.A.O/S	*
16	EZDGA10588	OUTBOARD BEARING WASHER, W.A.	*
17	EZDGA87	BOLT, 66" - 5 BLADE GANG KEYED	*
	EZDGA233	BOLT, 69-1/2" - 6 BLADE GANG KEYED	*
	EZDGA234	BOLT, 81-3/4" - 7 BLADE GANG KEYED	*
	EZDGA229	BOLT, 93-3/4" - 8 BLADE GANG KEYED	*
	EZDGA236	BOLT, 106-1/2" - 9 BLADE GANG KEYED	*
	EZDGA224	BOLT, 118-3/4" - 10 BLADE GANG KEYED	*
	88705107	BOLT, 131-1/4" - 11 BLADE GANG KEYED	*
	88705108	BOLT, 143-1/2" - 12 BLADE GANG KEYED	*
	88705109	BOLT, 156" - 13 BLADE GANG KEYED	*
18	88713493	BOLT, 5/8" NC X 10.-1/2" HEX CAP GR5 ZNCR - LESS WEAR GUARD	*
19	EZB062110	BOLT, 5/8" NC x 11" HEX CAP GR 5 ZNCR - WITH WEAR GUARD	*
20	EZBN062L	LOCK NUT, 5/8" NC NYLON	*
21	EZBN062	NUT, 5/8" GR 5 P	*
22	EZBW17506812F	FLAT WASHER, 11/16" ZNCR	*
23	EZDG10590	WEAR GUARD	*

*As Required

Gang Assembly, T2-215 Interlocking Bearings, 12 In. Spacing, 30 In. Blades, Keyed

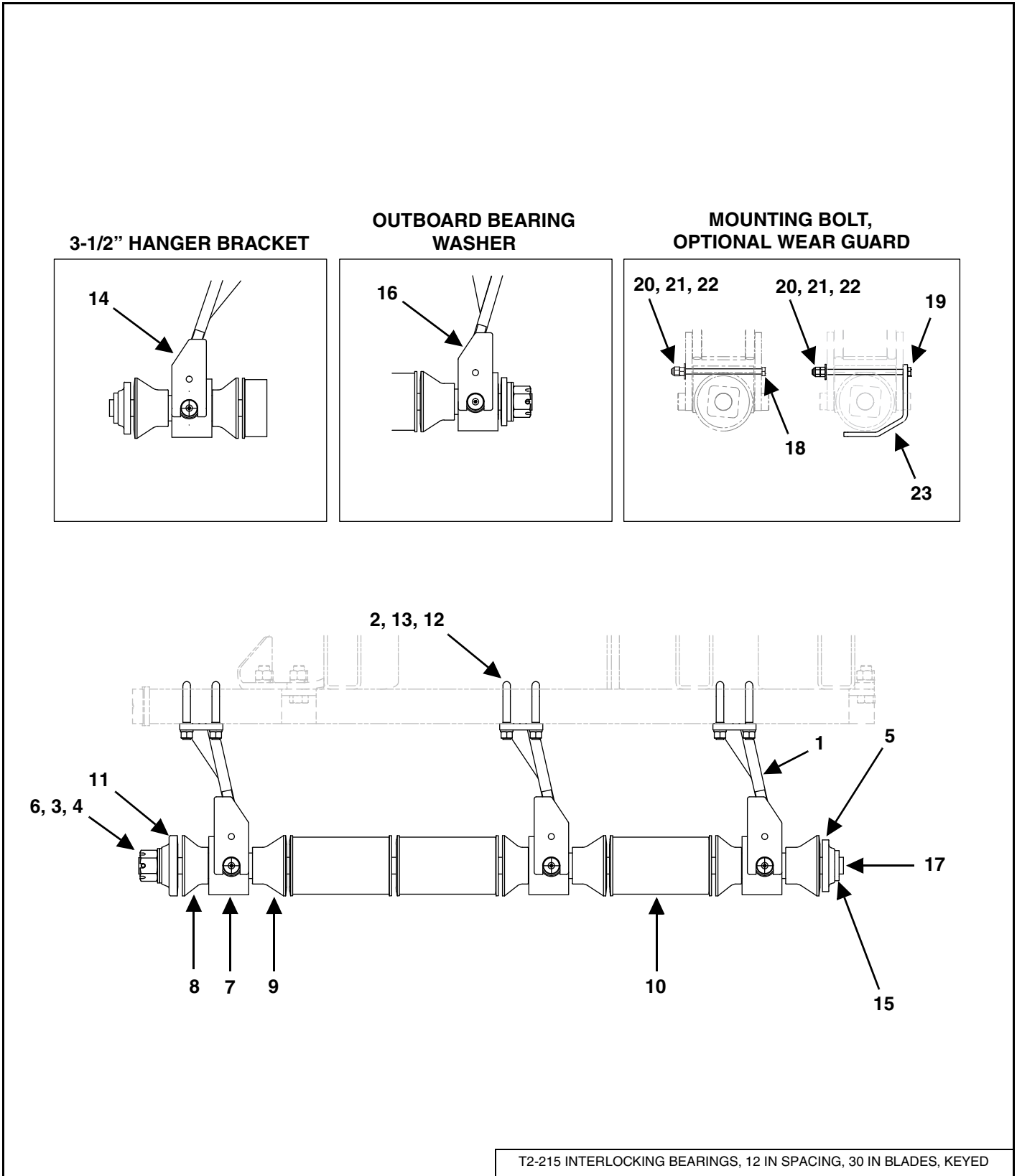

ITEM	PART NUMBER	DESCRIPTION	QTY
1	EZDGA13163	2" HANGER BRACKET, W.A. O/S	*
2	EZDG5379	U-BOLT 7/8" x 7"	*
3	EZDG82	NUT, 2" NC HEX SLOT GR 5 ZNCR	*
4	EZDG89	WASHER-SHIM	*
5	EZDGA5370	PLATE-END DISC GANG	*
6	EZDG10310	PIN-LOCK DISC GANG	*
7	EZDGB9940	BEARING-ASSY HSG DISC GANG	*
8	EZDG9919	SHORT HALF SPOOL 10-1/2" - 12"	*
9	EZDG9918	LONG HALF SPOOL 12" SPACING	*
10	EZDGA11081	SPOOL-W.A. FULL 12" SPACING	*
11	EZDG13180	KEYED WASHER, 7" x 2"	*
12	EZBN087	NUT, 7/8" HEX GR 5 ZNCR	*
13	EZBW087L	LOCK WASHER, 7/8" x 1-1/2" x 1/4" ZNCR	*
14	EZDGA13164	3-1/2" HANGER BRACKET, W.A.O/S	*
15	EZDG5371	PLATE-HOLDING LUG DISC GANG	*
16	EZDGA10588	OUTBOARD BEARING WASHER, W.A.	*
17	88713306	BOLT, 66" - 5 BLADE GANG KEYED	*
	88713403	BOLT, 69-1/2" - 6 BLADE GANG KEYED	*
	88713404	BOLT, 81-3/4" - 7 BLADE GANG KEYED	*
	88713405	BOLT, 93-3/4" - 8 BLADE GANG KEYED	*
	88713406	BOLT, 106-1/2" - 9 BLADE GANG KEYED	*
	88713407	BOLT, 118-3/4" - 10 BLADE GANG KEYED	*
	88713408	BOLT, 131-1/4" - 11 BLADE GANG KEYED	*
	88713409	BOLT, 143-1/2" - 12 BLADE GANG KEYED	*
	88713410	BOLT, 156" - 13 BLADE GANG KEYED	*
18	88713493	BOLT, 5/8" NC x 10-1/2" HEX CAP GR 5 ZNCR - LESS WEAR GUARD	*
19	EZB062110	BOLT, 5/8" NC x 11" HEX CAP GR 5 ZNCR - WITH WEAR GUARD	*
20	EZBN062L	LOCK NUT, 5/8" NC NYLON	*
21	EZBN062	NUT, 5/8" GR 5 P	*
22	EZBW17506812F	FLAT WASHER, 11/16" ZNCR	*
23	EZDG10590	WEAR GUARD	*

*As Required

Stone Flex Hanger Assembly

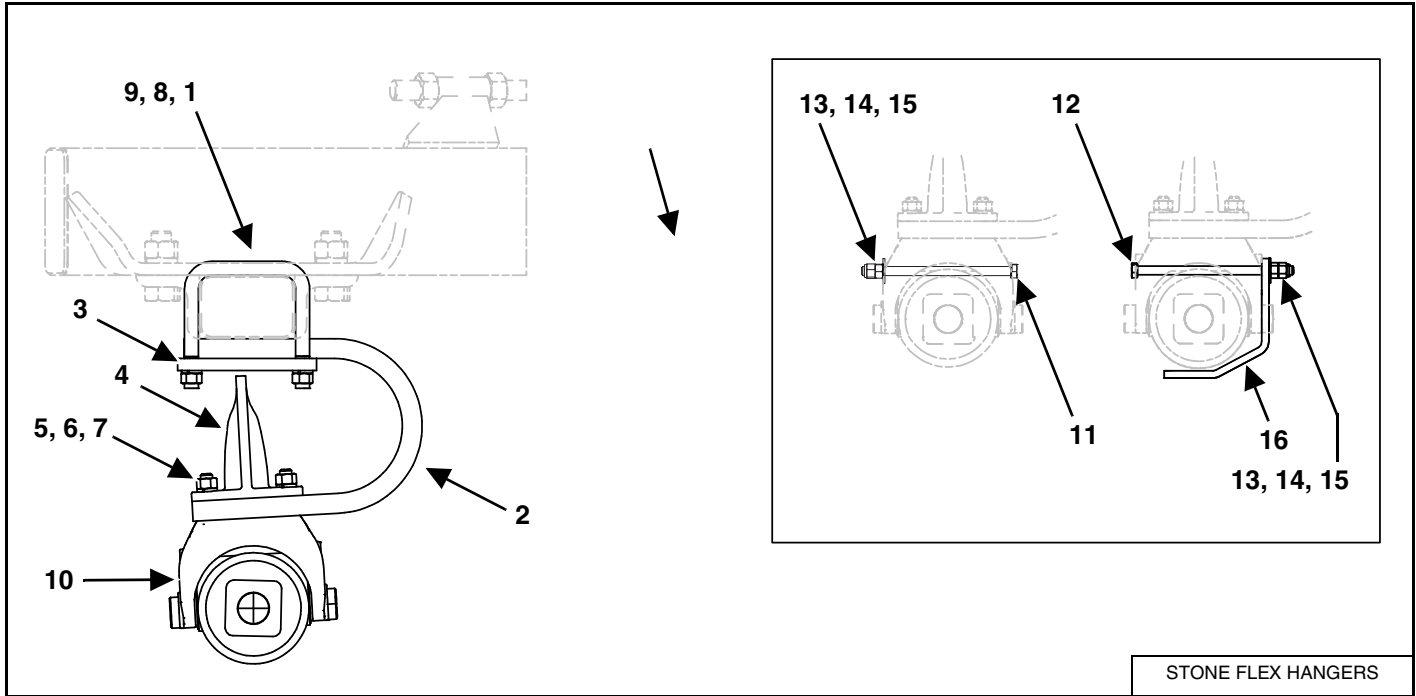

ITEM	PART NUMBER	DESCRIPTION	QTY
1	EZDG5378	U-BOLT, 7/8" x 6" x 7-1/8"	*
2	EZDG5313	STONE FLEX HANGER	*
3	EZDGA5327	STONE FLEX HANGER MOUNT	*
4	88712866	STONE FLEX HANGER STOP	*
5	EZBW075L	LOCK WASHER, 3/4" x 1-1/4" x 3/16" ZNCR	*
6	EZBN075	NUT, 3/4" NC HEX GR 5 ZNCR	*
7	EZB075035	BOLT, 3/4" NC x 3-1/2" HEX	*
8	EZBN087	NUT, 7/8" HEX GR 5 ZNCR	*
9	EZBW087L	LOCK WASHER, 7/8" x 1-1/2" x 1/4" ZNCR	*
10	EZDGA10570	STANDARD 215 BEARING BRACKET, W.A.	*
	EZDGA10575	2" OFFSET 215 BEARING BRACKET	*
	EZDGA10576	3.5" OFFSET 215 TRUNION MOUNTING BRACKET	*
11	88713493	BOLT, 5/8" NC x 10.5" HEX CAP GR 5 ZNCR - LESS WEAR GUARD	*
12	EZB062110	BOLT, 5/8" NC x 11" HEX CAP GR 5 ZNCR - WITH WEAR GUARD	*
13	EZBN062L	LOCK NUT, 5/8" NC NYLON	*
14	EZBN062	NUT, 5/8" GR 5 P	*
15	EZBW17506812F	FLAT WASHER, 11/16" ZNCR	*
16	EZDG10590	WEAR GUARD	*

*As Required

T2-215 Bearing Assembly

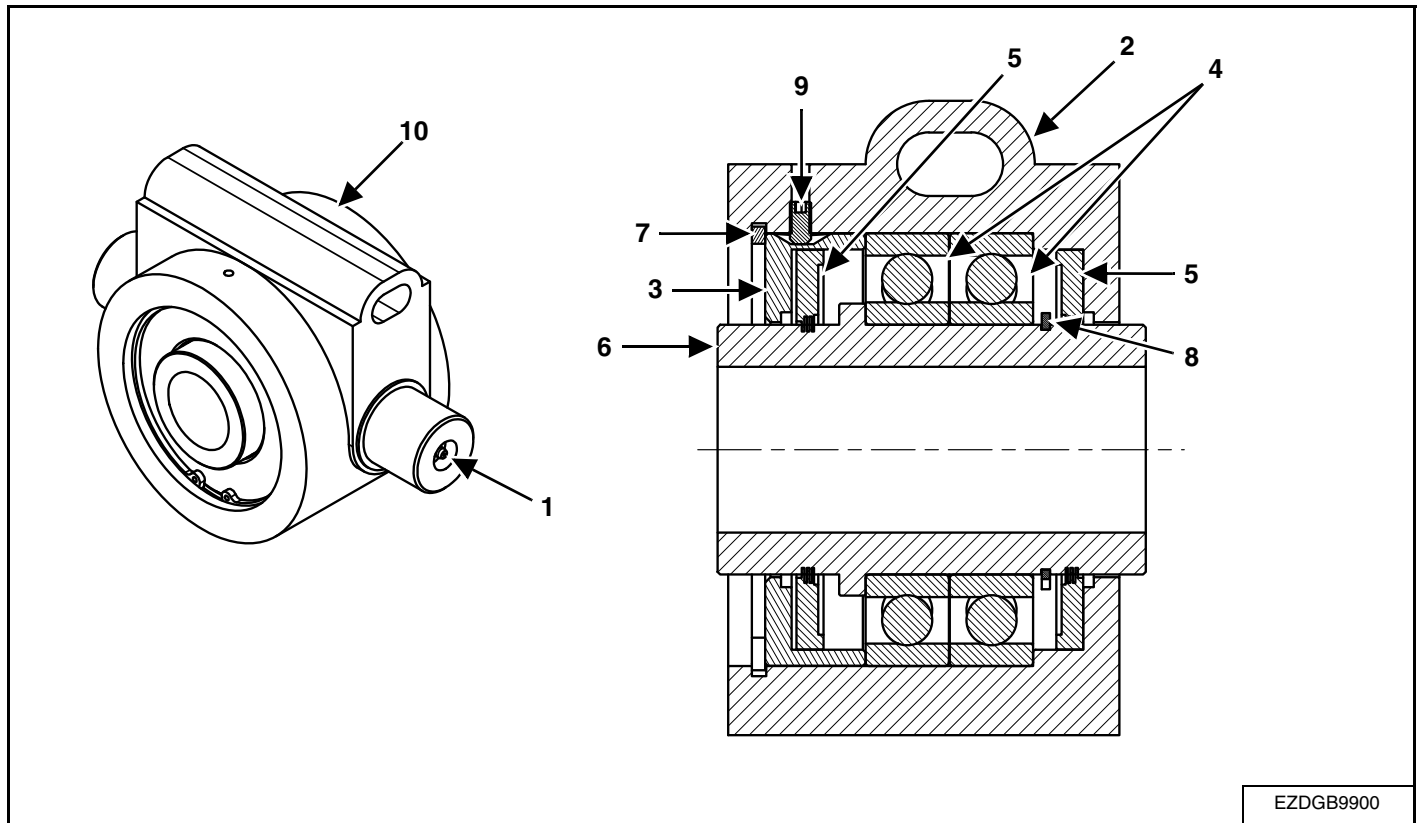

ITEM	PART NUMBER	DESCRIPTION	QTY
1	EZ10GN1	GREASE ZERK, 1/4" UNF ST	2
2	EZDG9901	BEARING HOUSING, T2-215	1
3	EZDG9902	BEARING HOUSING CAP	1
4	EZDG9904	BALL BEARING, T2-215	2
5	EZDG9905	BEARING SEAL, T2-215	2
6	EZDG9906	BEARING SLEEVE	1
7	EZDG9910	INTERIOR RETAINING RING, 130 MM OD	1
8	EZDG9911	EXTERIOR RETAINING RING, 72 MM ID	1
9	EZDG9912	SCREW SET, 1/4" NF x 1/2"	1
10	EZDGB9900	COMPLETE T2 - 215 BEARING ASSEMBLY	1

*As Required

T2-215 Bearing Assembly, 7-3/16 In. Sleeve

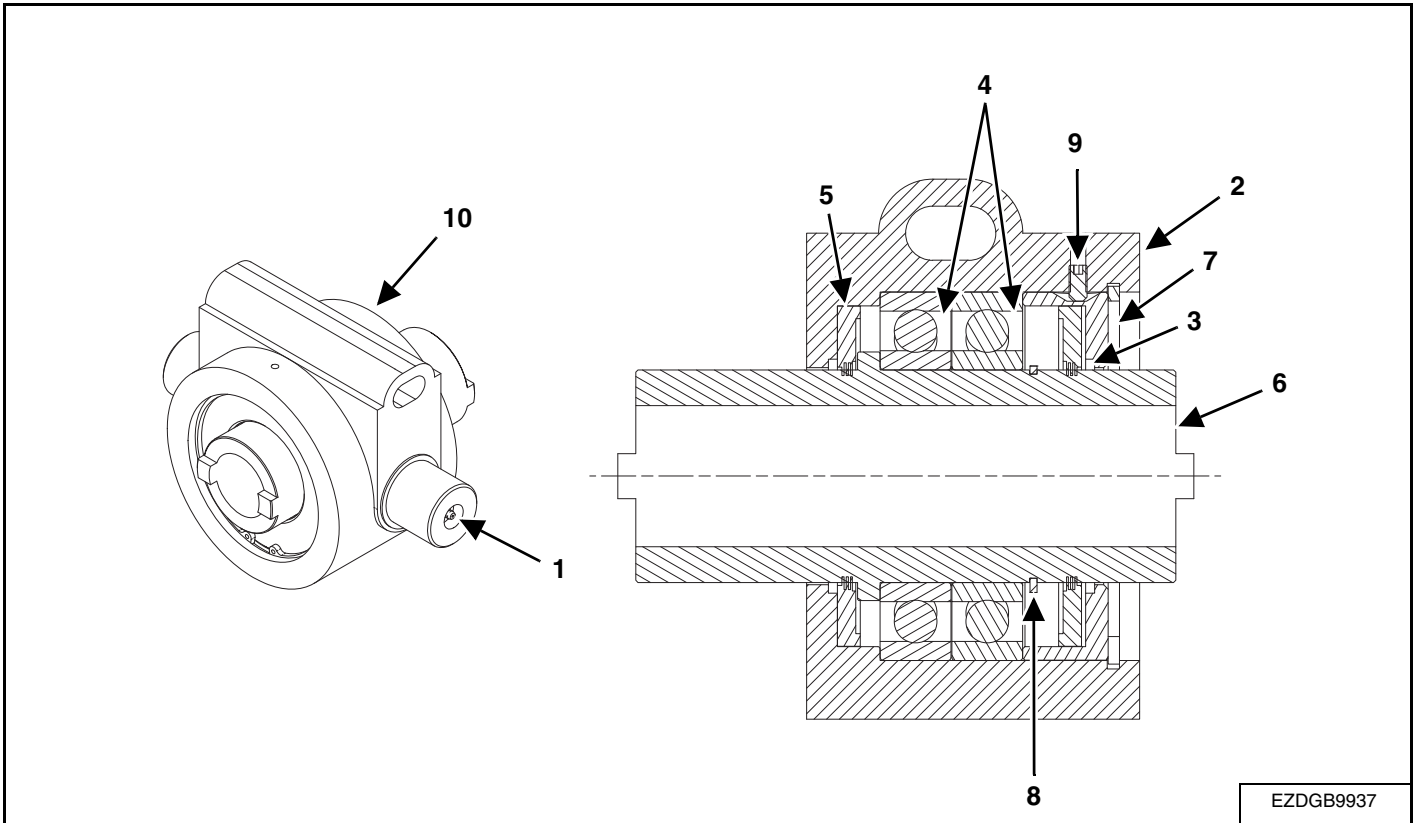

ITEM	PART NUMBER	DESCRIPTION	QTY
1	EZ10GN1	GREASE ZERK, 1/4" UNF ST	2
2	EZDG9901	BEARING HOUSING, T2-215	1
3	EZDG9902	BEARING HOUSING CAP	1
4	EZDG9904	BALL BEARING, T2-215	2
5	EZDG9905	BEARING SEAL, T2-215	2
6	EZDG9924	BEARING SLEEVE - 7-3/16" LONG	1
7	EZDG9910	INTERIOR RETAINING RING, 130 MM OD	1
8	EZDG9911	EXTERIOR RETAINING RING, 72 MM ID	1
9	EZDG9912	SCREW SET, 1/4" NF x 1/2"	1
10	EZDGB9937	COMPLETE T2-215 BEARING ASSEMBLY - 7-3/16" SLEEVE	1

*As Required

T2-215 Bearing Assembly, 9 In. Sleeve

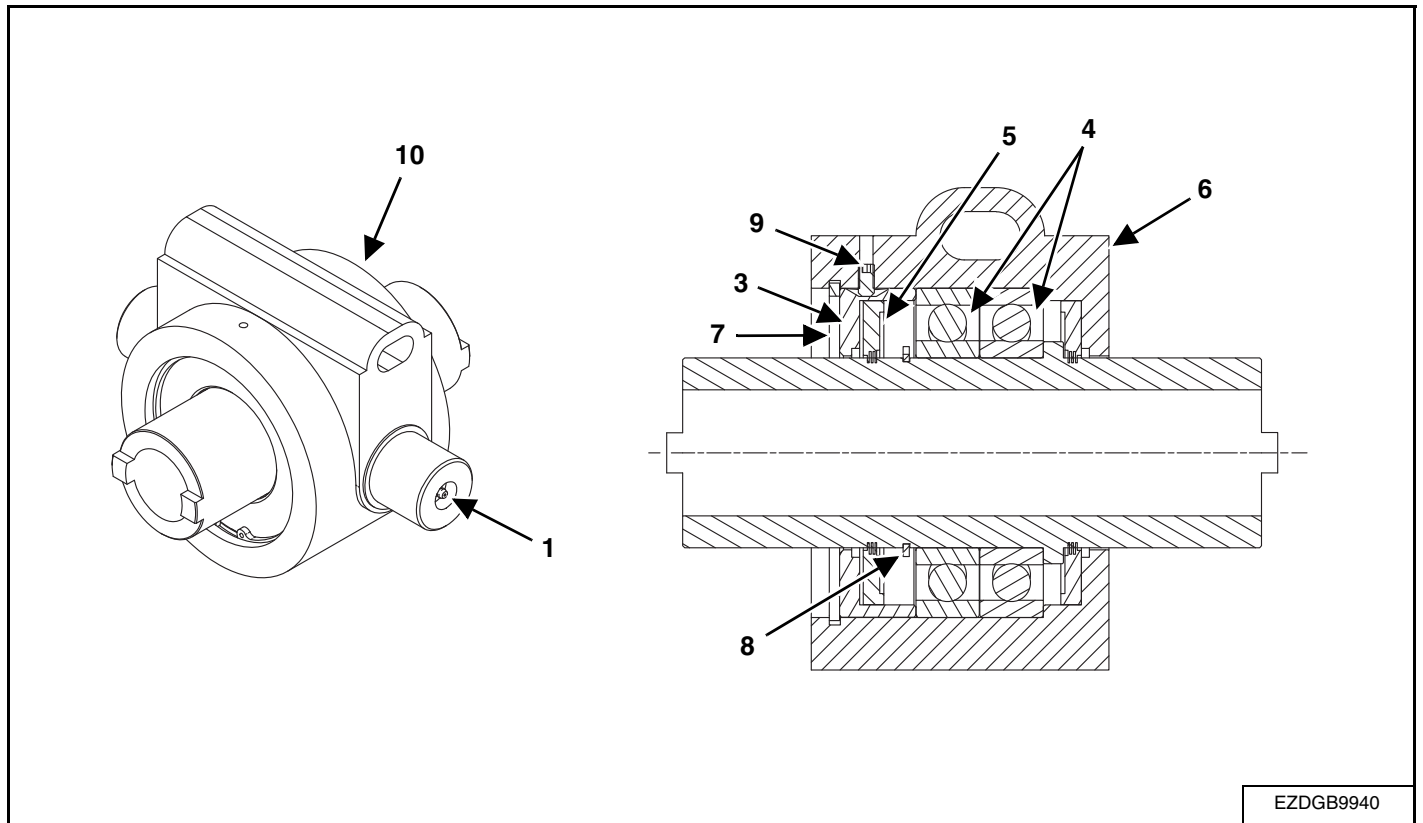

EZDGB9940

ITEM	PART NUMBER	DESCRIPTION	QTY
1	EZ10GN1	GREASE ZERK, 1/4" UNF ST	2
2	EZDG9901	BEARING HOUSING, T2-215	1
3	EZDG9902	BEARING HOUSING CAP	1
4	EZDG9904	BALL BEARING, T2-215	2
5	EZDG9905	BEARING SEAL, T2-215	2
6	EZDG9922	BEARING SLEEVE - 9" LONG	1
7	EZDG9910	INTERIOR RETAINING RING, 130 MM OD	1
8	EZDG9911	EXTERIOR RETAINING RING, 72 MM ID	1
9	EZDG9912	SCREW SET, 1/4" NF x 1/2"	1
10	EZDGB9940	COMPLETE T2-215 BEARING ASSEMBLY - 9" SLEEVE	1

*As Required

Farm King



SPECIFICATIONS

SPECIFICATIONS195
 Dimensions195
 Performance196
 Hydraulic Cylinders196
 Bolt Torques196

HYDRAULIC SCHEMATIC (SUPER NARROW WING)197

HYDRAULIC SCHEMATIC (NARROW)198

HYDRAULIC SCHEMATIC (WIDE WING)199

HARDWARE TORQUE VALUES200
 Metric Chart200
 Imperial Chart201

HYDRAULIC CONNECTION SPECIFICATIONS202
 O-Ring Fitting (Straight Thread)202
 O-ring Face Seal Connection202
 Flare Fitting202
 Port Seal (O-ring Boss) Fitting202
 Tubelines And Hoses202

Farm King



SPECIFICATIONS

Dimensions

MODEL	WING WIDTH	BLADE SPACING	APPROX. CUTTING WIDTH	# OF BLADES	# OF GANG BEARINGS	GANG BEARING TYPE	WING LIFT CYLINDER		APPROX. TRANSPORT WIDTH	APPROX. TRANSPORT HEIGHT
							#	Size		
58SN	Super Narrow	10-1/2 in.	25 ft.	58	20	T2 - 215	2	4 in. x 36 in.	17 ft.	10 ft. 11 in.
62SN	Super Narrow	10-1/2 in.	26 ft. 6 in.	62	20	T2 - 215	2	4 in. x 36 in.	17 ft.	11 ft. 9 in.
66N	Narrow	10-1/2 in.	29 ft.	66	22	T2 - 215	2	5 in. x 36 in.	17 ft.	12 ft. 7 in.
74N	Narrow	10-1/2 in.	32 ft.	74	24	T2 - 215	2	5 in. x 36 in.	17 ft.	14 ft. 2 in.
82W	Wide	10-1/2 in.	35 ft. 6 in.	82	28	T2 - 215	4	5 in. x 36 in.	17 ft.	15 ft. 10 in.
90W	Wide	10-1/2 in.	38 ft. 6 in.	90	21	T2 - 215	4	5 in. x 36 in.	17 ft.	17 ft. 5 in.
50SN	Super Narrow	12 in.	24 ft.	50	20	T2 - 215	2	4 in. x 36 in.	17 ft.	10 ft. 9 in.
54SN	Super Narrow	12 in.	26 ft.	54	20	T2 - 215	2	4 in. x 36 in.	17 ft.	11 ft. 8 in.
58N	Narrow	12 in.	28 ft. 6 in.	58	22	T2 - 215	2	5 in. x 36 in.	17 ft.	12 ft. 7 in.
66N	Narrow	12 in.	32 ft. 6 in.	66	24	T2 - 215	2	5 in. x 36 in.	17 ft.	14 ft. 6 in.
74W	Wide	12 in.	36 ft. 6 in.	74	26	T2 - 215	4	5 in. x 36 in.	17 ft.	16 ft. 3 in.
78W	Wide	12 in.	38 ft. 6 in.	78	28	T2 - 215	4	5 in. x 36 in.	17 ft.	17 ft. 2 in.

Performance

DESCRIPTION	8700	
	10-1/2 IN. (267 MM) SPACING	12 IN. (305 MM) SPACING
Weight*	700 lb. / ft. Class (1042 kg)	700 lb. / ft. Class (1042 kg)
Horsepower Required	7.0 to 8.0 DBHP / Foot (5.2 to 6.0 kW per 305 mm)†	
Frame	Welded, 8 in. x 4 in. x 0.375 in. Wall (152 x 102 x 9.5 mm Wall) Tubular Steel Frame	
Bearings	T2-215 Series Trunnion Mounted Bearings	
Gang Angle	21° Front / 19° Rear	21° Front / 19° Rear
Gang Shaft	1-15/16 in. (49 mm) High Carbon Steel, Factory Torqued to 3200 ft. / lb. (4339 N•m)	
Blades (Notched / Smooth)	26 in. x 5/16 in. (660 mm x 8 mm)	26 in. x 5/16 in. (660 mm x 8 mm)
	26 in. x 3/8 in. (660 mm x 9 mm)	26 in. x 3/8 in. (660 mm x 9 mm)
	28 in. x 3/8 in. (711 mm x 9 mm)	28 in. x 3/8 in. (711 mm x 9 mm)
		30 in. x 3/8 in. (762 mm x 9 mm)
Depth Control	3-Cylinder Series System C/W Depth Stop Segments	3-Cylinder Series System C/W Depth Stop Segments
	Auto-Leveling, Full Floating Hitch	
Tires (Center Frame)	(4) FS24-380/55R 16.5	
Tires (Wing Frame)	(2) 12.5L x 15 FI (24 ft. - 26 ft.) / (4) 12.5L x 15 FI (26 ft. 6 in. - 38 ft. 6 in.) (Optional FS24-380/55R16.5)	
* W/24 in. Blades		
† Depends on working depth, soil type, field speed, etc.		

Hydraulic Cylinders

CYLINDER LOCATION	CYLINDER SIZE	# REQUIRED
Center Frame Rockshaft (24 ft. - 32-1/2 ft.)	4 in. x 24 in. Rephasing	1
Center Frame Rockshaft (35-1/2 ft. - 38-1/2 ft.)	4-1/2 in. x 24 in. Rephasing	1
L.H. Wing Rockshaft (24 ft. - 32-1/2 ft.)	3-1/2 in. x 24 in. Rephasing	1
L.H. Wing Rockshaft (35-1/2 ft. - 38-1/2 ft.)	4 in. x 24 in. Rephasing	1
R.H. Wing Rockshaft (24 ft. - 32-1/2 ft.)	3 in. x 24 in. Rephasing	1
R.H. Wing Rockshaft (35-1/2 ft. - 38-1/2 ft.)	3-1/2 in. x 24 in. Rephasing	1
Wing Fold (24 - 26-1/2 ft.)	4 in. x 36 in. Rephasing	2
Wing Fold (28-1/2 ft. - 32-1/2 ft.)	5 in. x 36 in. Rephasing	2
Wing Fold (35-1/2 ft. - 38-1/2 ft.)	5 in. x 36 in. Rephasing	4

Bolt Torques

DESCRIPTION	TORQUE
Gang Bolts (1-15/16 in. (49 mm) diameter)	3200 ft. / lb. (4339 N•m)
Gang Beam Bolts (1-1/4 in. (31 mm) diameter)	840 ft. / lb. (1139.2 N•m)
Leveling Crank Bolts (1-1/4 in. (31 mm) diameter)	840 ft. / lb. (1139.2 N•m)
Wheel Bolts (9/16 in. (14 mm) diameter)	130 ft. / lb. (176.3 N•m)
Bearing Hanger U-bolts - 7/8 in. (15 mm) diameter)	430 ft. / lb. (583 N•m) (Solid Hangers)

HYDRAULIC SCHEMATIC (SUPER NARROW WING)

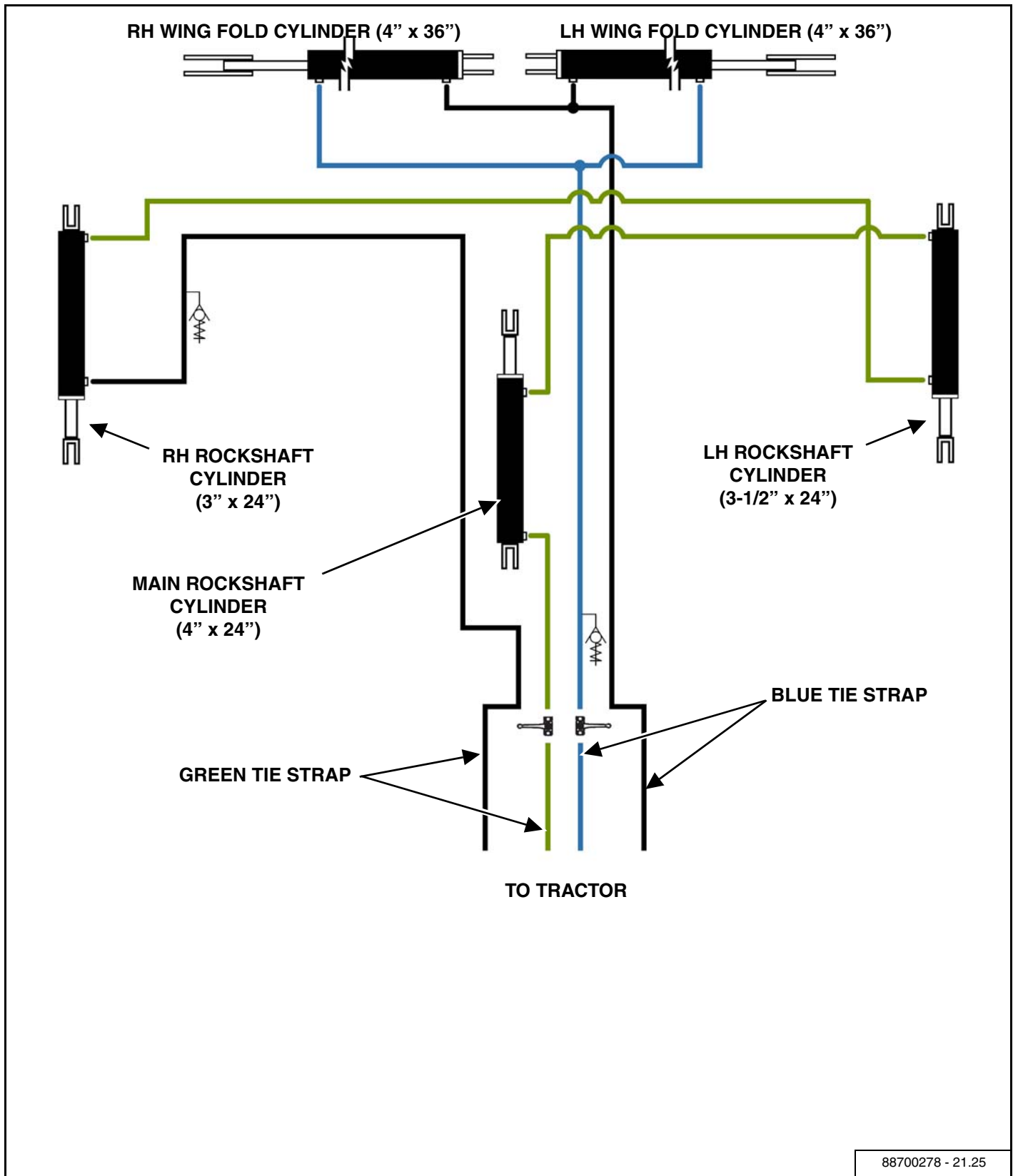

HYDRAULIC SCHEMATIC (NARROW)

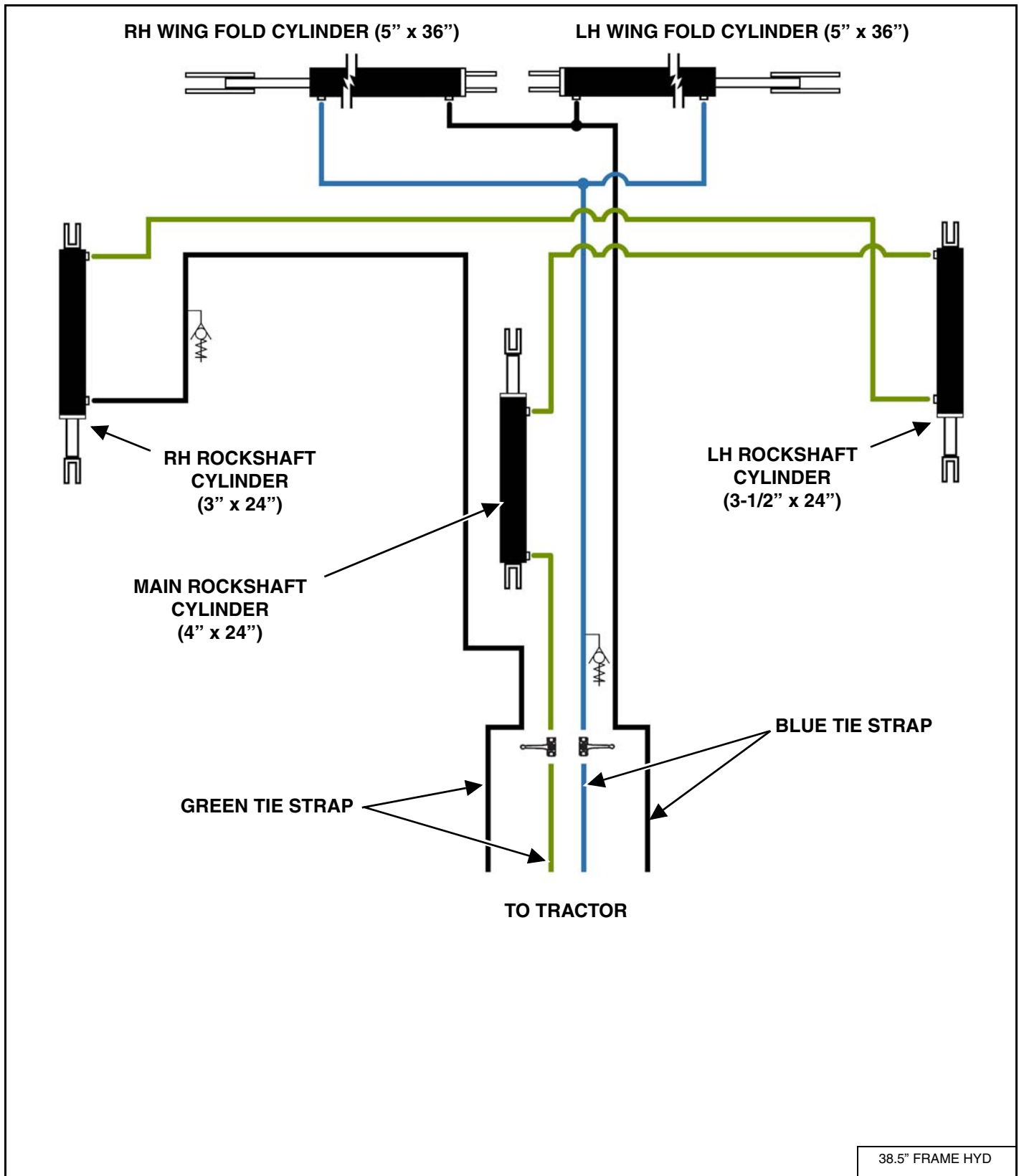

HYDRAULIC SCHEMATIC (WIDE WING)

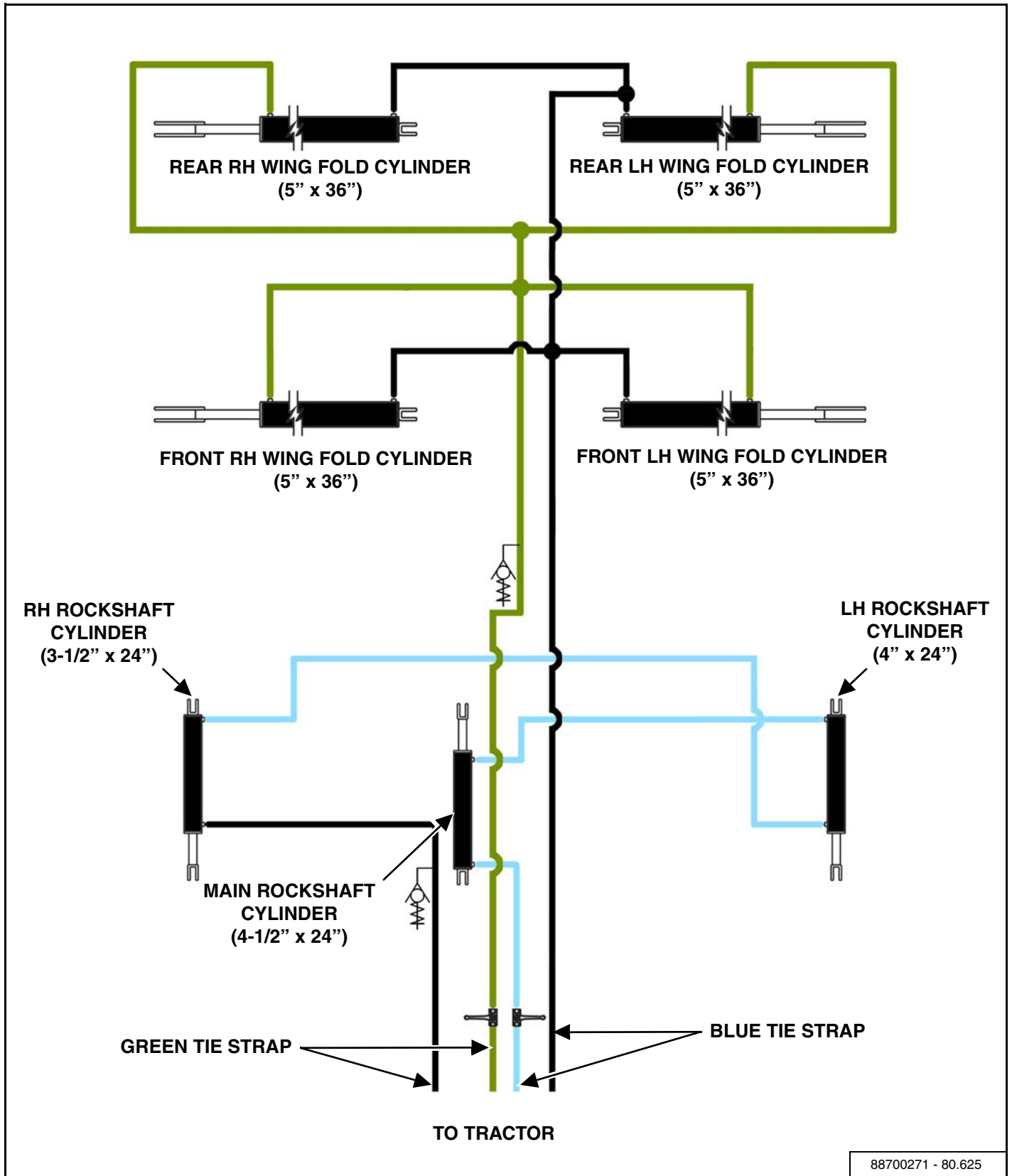

88700271 - 80.625

HARDWARE TORQUE VALUES

Metric Chart

NOTE: Do not use the values listed in the charts if a different torque value or tightening procedure is specified in this manual for a specific application. Torque values listed are for general use only.

Use the following charts to determine the correct torque when checking, adjusting or replacing hardware. **Torque values are listed in newton-meters (inch* or foot pounds) for normal assembly applications.**

Nominal Size	Class 5.8		Class 8.8		Class 10.9		Lock nuts
	Unplated	Plated W / ZnCr	Unplated	Plated W / ZnCr	Unplated	Plated W / ZnCr	CL.8 w/ CL. 8.8 Bolt
M4	1.7 (15*)	2.2 (19*)	2.6 (23*)	3.4 (30*)	3.7 (33*)	4.8 (42*)	1.8 (16*)
M6	5.8 (51*)	7.6 (67*)	8.9 (79*)	12 (102*)	13 (115*)	17 (150*)	6.3 (56*)
M8	14 (124*)	18 (159*)	22 (195*)	28 (248*)	31 (274*)	40 (354*)	15 (133*)
M10	28 (21)	36 (27)	43 (32)	56 (41)	61 (45)	79 (58)	30 (22)
M12	49 (36)	63 (46)	75 (55)	97 (72)	107 (79)	138 (102)	53 (39)
M16	121 (89)	158 (117)	186 (137)	240 (177)	266 (196)	344 (254)	131 (97)
M20	237 (175)	307 (226)	375 (277)	485 (358)	519 (383)	671 (495)	265 (195)
M24	411 (303)	531 (392)	648 (478)	839 (619)	897 (662)	1160 (855)	458 (338)

NOTE: Torque values shown with * are inch pounds.

Identification of Hex Cap Screws and Carriage Bolts - Classes 5 and up

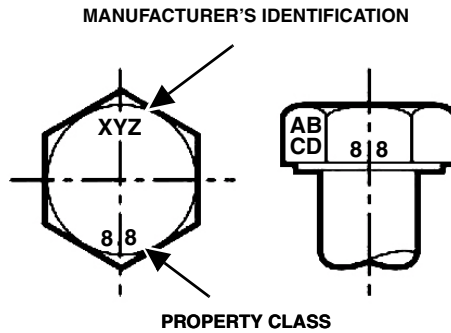

Identification of Hex Nuts and Lock Nuts - Classes 5 and up

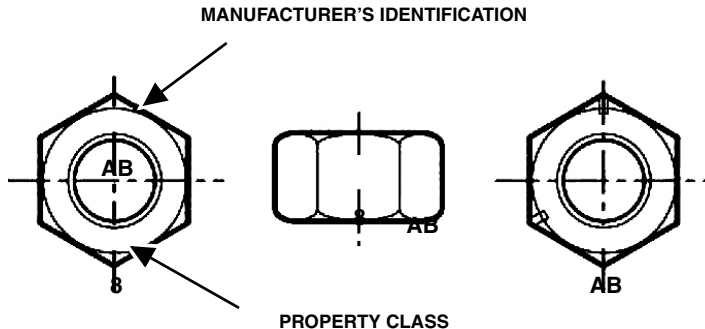

HARDWARE TORQUE VALUES (CONT'D)

Imperial Chart

NOTE: Do not use the values listed in the charts if a different torque value or tightening procedure is specified in this manual for a specific application. Torque values listed are for general use only.

Use the following charts to determine the correct torque when checking, adjusting or replacing hardware. **Torque values are listed in newton-meters (inch* or foot pounds) for normal assembly applications.**

Nominal Size	SAE Grade 5		SAE Grade 8		LOCK NUTS			
	Unplated or Plated Silver	Plated W / ZnCr Gold	Unplated or Plated Silver	Plated W / ZnCr Gold	Unplated or Plated Silver	Plated W / ZnCr Gold	Grade W / Gr. 5 Bolt	Grade W / Gr. 8 Bolt
1/4	6.2 (55*)	8.1 (72*)	9.7 (86*)	12.6 (112*)	13.6 (121*)	17.7 (157*)	6.9 (61*)	9.8 (86*)
5/16	13 (115*)	17 (149*)	20 (178*)	26 (229*)	28 (250*)	37 (324*)	14 (125*)	20 (176*)
3/8	23 (17)	30 (22)	35 (26)	46 (34)	50 (37)	65 (48)	26 (19)	35 (26)
7/16	37 (27)	47 (35)	57 (42)	73 (54)	80 (59)	104 (77)	41 (30)	57 (42)
1/2	57 (42)	73 (54)	87 (64)	113 (83)	123 (91)	159 (117)	61 (45)	88 (64)
9/16	81 (60)	104 (77)	125 (92)	163 (120)	176 (130)	229 (169)	88 (65)	125 (92)
5/8	112 (83)	145 (107)	174 (128)	224 (165)	244 (180)	316 (233)	122 (90)	172 (127)
3/4	198 (146)	256 (189)	306 (226)	397 (293)	432 (319)	560 (413)	217 (160)	306 (226)
7/8	193 (142)	248 (183)	495 (365)	641 (473)	698 (515)	904 (667)	350 (258)	494 (364)
1	289 (213)	373 (275)	742 (547)	960 (708)	1048 (773)	1356 (1000)	523 (386)	739 (545)

NOTE: Torque values shown with * are inch pounds.

Identification of Hex Cap Screws and Carriage Bolts



SAE GRADE 2 BOLTS



SAE GRADE 5 BOLTS



SAE GRADE 8 BOLTS



SAE GRADE 2 NUTS



SAE GRADE 5 NUTS



SAE GRADE 8 NUTS

Identification of Hex Nuts and Lock Nuts

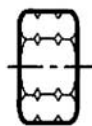

Grade A - No Notches

Grade B - One Circumferential Notch

Grade C - Two Circumferential Notches

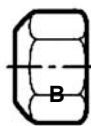

Grade A - No Mark

Grade B - Letter B

Grade C - Letter C

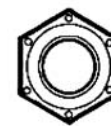

Grade A - No Marks

Grade B - Three Marks

Grade C - Six Marks

(Marks not always located at corners)

HYDRAULIC CONNECTION SPECIFICATIONS

O-Ring Fitting (Straight Thread)

Lubricate the O-ring before installing the fitting. Loosen the jam nut and install the fitting. Tighten the jam nut until the washer is tight against the surface.

O-ring Face Seal Connection

Figure 169

O-ring Face Seal Tightening Torque		
Tubeline O.D.	Thread Size	N•m (ft-lb)
1/4"	9/16" - 18	13 (18)
3/8"	11/16" - 16	22 (30)
1/2"	13/16" - 16	40 (54)
5/8"	1" - 14	60 (81)
3/4"	1-3/16" - 12	84 (114)
7/8"	1-3/16" - 12	98 (133)
1"	1-7/16" - 12	118 (160)
1-1/4"	1-11/16" - 12	154 (209)
1-1/2"	2" - 12	163 (221)

When the fitting is tightened, you can feel when the fitting is tight to eliminate leakage caused by under or over torqued fittings. Use petroleum jelly to hold the O-ring in position until the fittings are assembled.

Flare Fitting

Figure 170

Flare Fitting Tightening Torque		
Tubeline O.D.	Thread Size	N•m (ft-lb)
1/4"	7/16" - 20	13 (18)
5/16"	1/2" - 20	17 (23)
3/8"	9/16" - 18	22 (30)
1/2"	3/4" - 16	40 (54)
5/8"	7/8" - 14	60 (81)
3/4"	1-1/16" - 12	84 (114)
7/8"	1-3/16" - 12	98 (133)
1"	1-5/16" - 12	118 (160)
1-1/4"	1-5/8" - 12	154 (209)
1-1/2"	1-7/8" - 12	163 (221)
2"	2-1/2" - 12	252 (342)

Tighten until the nut makes contact with the seat. Use the chart [Figure 170] to find the correct tightness needed.

NOTE: If the fitting leaks, disconnect and inspect the seat area for damage.

Port Seal (O-ring Boss) Fitting

Figure 171

Port Seal And O-ring Boss Tightening Torque		
Tubeline O.D.	Thread Size	N•m (ft-lb)
1/4"	7/16" - 20	13 (18)
3/8"	9/16" - 18	22 (30)
1/2"	3/4" - 16	40 (54)
5/8"	7/8" - 14	60 (81)
3/4"	1-1/16" - 12	84 (114)
7/8"	1-3/16" - 12	98 (133)
1"	1-5/16" - 12	118 (160)
1-1/8"	1-7/16" - 12	154 (209)
1-1/4"	1-5/8" - 12	163 (221)

NOTE: Port seal and nut, washer and O-ring (O-ring Boss) fittings use the same tightening torque valve chart.

If a torque wrench cannot be used, use the following method.

Tighten the nut until it just makes metal to metal contact, you can feel the resistance.

Tighten the nut with a wrench no more than one hex flat maximum.

Do not over tighten the port seal fitting.

NOTE: If a torque wrench cannot be used, use the hex flat tightening method as an approximate guideline.

NOTE: Port seal fittings are not recommended in all applications. Use O-ring boss fittings in these applications.

Tubelines And Hoses

Replace any tubelines that are bent or flattened. They will restrict flow, which will slow hydraulic action and cause heat.

Replace hoses which show signs of wear, damage or weather cracked rubber.

Always use two wrenches when loosening and tightening hose or tubeline fittings.

WARRANTY

WARRANTY205

Farm King



WARRANTY**Limited Warranty****BASE LIMITED WARRANTY**

Farm King provides this warranty only to original retail purchasers of its products. Farm King warrants to such purchasers that all Farm King manufactured parts and components used and serviced as provided for in the Operator's Manual shall be free from defects in materials and workmanship for a period following delivery to the original retail purchaser of three (3) years. This limited warranty applies only to those parts and components manufactured by Farm King. Parts and components manufactured by others are subject to their manufacturer's warranties, if any.

100% Parts and Labor are covered for the first year.

100% Parts only, are covered for the second year.

50% Parts only, are covered for the third year.

Farm King will fulfill this limited warranty by, at its option, repairing or replacing any covered part that is defective or is the result of improper workmanship, provided that the part is returned to Farm King within thirty (30) days of the date that such defect or improper workmanship is, or should have been, discovered. Parts must be returned through the selling representative and the buyer must prepay transportation charges.

Farm King will not be responsible for repairs or replacements that are necessitated, in whole or part, by the use of parts not manufactured by or obtained from Farm King. Under no circumstances are component parts warranted against normal wear and tear. There is no warranty on product pump seals, product pump bearings, rubber product hoses, pressure gauges, or other components that require replacement as part of normal maintenance.

Farm King warrants that the following disc gang bearing parts used and serviced as provided for in the Operator's Manual shall be free from defects in materials and workmanship for an extended period following delivery to the original retail purchaser.

410WSS bearings are covered for three (3) years. Coverage for the 2nd and 3rd year (12-36 months) is limited to part replacement only. Labour is not included.

T2-215 bearings are covered for seven (7) years. Extended coverage (12-84 months) is limited to replacement of ball bearings and seals only. Labour and associated bearing parts are not included.

REPAIR PARTS LIMITED WARRANTY

Farm King warrants genuine Farm King replacement parts purchased after the expiration of the Farm King Limited Warranty, and used and serviced as provided for in the Operator's Manual, to be free from defects in materials or workmanship for a period of thirty (30) days from the invoice date for the parts. Farm King will fulfill this limited warranty by, at its option, repairing or replacing any covered part that is defective or is the result of improper workmanship, provided that the part is returned to Farm King within thirty (30) days of the date that such defect or improper workmanship is, or should have been, discovered. Such parts must be shipped to the Farm King factory at the purchaser's expense.

COMMERCIAL USE

Warranty for commercial (other than bona fide farmers), rental, or custom use is limited to 100% parts and labor for ninety (90) days.

WHAT IS NOT COVERED

Under no circumstances does this limited warranty cover any components or parts that have been subject to the following: negligence; alteration or modification not approved by Farm King; misuse; improper storage; lack of reasonable and proper maintenance, service, or repair; normal wear; damage from failure to follow operating instructions; accident; and/or repairs that have been made with parts other than those manufactured, supplied, and / or authorized by Farm King.

AUTHORIZED DEALER AND LABOR COSTS

Repairs eligible for labor under this limited warranty must be made by Farm King or an authorized Farm King dealer. Farm King retains the exclusive discretion to determine whether it will pay labor costs for warranty repairs or replacements, and the amount of such costs that it will pay and the time in which the repairs will be made. If Farm King determines that it will pay labor costs for warranty work, it will do so by issuing a credit to the dealer's or distributor's account. Farm King will not approve or pay invoices sent for repairs that Farm King has not previously approved. Warranty service does not extend the original term of this limited warranty.

Limited Warranty

WARRANTY REQUIREMENTS

To be covered by warranty, each new product must be registered with Farm King within thirty (30) days of delivery to original retail purchaser. If the customer decides to purchase replacement components before the warranty disposition of such components is determined, Farm King will bill the customer for such components and then credit the replacement invoice for those components later determined to be covered by this limited warranty. Any such replacement components that are determined not be covered by this limited warranty will be subject to the terms of the invoice and shall be paid for by the purchaser.

EXCLUSIVE EFFECT OF WARRANTY AND LIMITATION OF LIABILITY

TO THE EXTENT PERMITTED BY LAW, FARM KING DISCLAIMS ANY WARRANTIES, REPRESENTATIONS, OR PROMISES, EXPRESS OR IMPLIED, AS TO THE QUALITY, PERFORMANCE, OR FREEDOM FROM DEFECT OF THE COMPONENTS AND PARTS COVERED BY THIS WARRANTY AND NOT SPECIFICALLY PROVIDED FOR HEREIN.

TO THE EXTENT PERMITTED BY LAW, FARM KING DISCLAIMS ANY IMPLIED WARRANTIES OF MERCHANTABILITY AND FITNESS FOR A PARTICULAR PURPOSE ON ITS PRODUCTS COVERED HEREIN, AND DISCLAIMS ANY RELIANCE BY THE PURCHASER ON FARM KING'S SKILL OR JUDGMENT TO SELECT OR FURNISH GOODS FOR ANY PARTICULAR PURPOSE. THE PURCHASER'S ONLY AND EXCLUSIVE REMEDIES IN CONNECTION WITH THE BREACH OR PERFORMANCE OF ANY WARRANTY ON FARM KING'S PRODUCTS ARE THOSE SET FORTH HEREIN. IN NO EVENT SHALL FARM KING BE LIABLE FOR INCIDENTAL OR CONSEQUENTIAL DAMAGES (INCLUDING, BY WAY OF EXAMPLE ONLY AND NOT LIMITATION, LOSS OF CROPS, LOSS OF PROFITS OR REVENUE, OTHER COMMERCIAL LOSSES, INCONVENIENCE, OR COST OF REPLACEMENT OF RENTAL EQUIPMENT). IN NO EVENT SHALL FARM KING'S CONTRACT OR WARRANTY LIABILITY EXCEED THE PURCHASE PRICE OF THE PRODUCT. (Note that some states do not allow limitations on how long an implied warranty lasts or the exclusion or limitation of incidental or consequential damages, so the above limitations and exclusion may not apply to you.) This warranty gives you specific legal rights and you may also have other rights, which vary from state to state.

Farm King neither assumes nor authorizes any person or entity, including its selling representatives, to assume any other obligations or liability in connections with the sale of covered equipment, or to make any other warranties, representations, or promises, express or implied, as to the quality, performance, or freedom from defect of the components and parts covered herein. No one is authorized to alter, modify, or enlarge this limited warranty, or its exclusions, limitations and reservations.

Corrections of defects and improper workmanship in the manner, and for the applicable time periods, provided for herein shall constitute fulfillment of all responsibilities of Farm King to the purchaser, and Farm King shall not be liable in negligence, contract, or on any other basis with respect to the subject equipment.

This limited warranty is subject to any existing conditions of supply which may directly affect Farm King's ability to obtain materials or manufacturer replacement parts.

Buhler Industries Inc. reserves the right to make improvements in design or changes in specifications to its products at anytime, without incurring any obligation to owners of units previously sold.

ALPHABETICAL INDEX

ADDITIONAL OPERATING RECOMMENDATIONS	103	SERVICE SCHEDULE	109
AXLES	115	SERVICING T2-215 BEARINGS (IMPORTANT NOTES)	117
BASE GROUP	28	SPECIFICATIONS	195
BEARING HANGERS	113	STORAGE AND RETURN TO SERVICE ..	125
CLEANING THE TANDEM DISC	117	TRANSPORTING	104
DEPTH STOPS	81	TROUBLESHOOTING	107
EQUIPMENT DECALS AND SIGNS	23	WALKING BEAMS	118
EQUIPMENT IDENTIFICATION	10	WARRANTY REGISTRATION FORM	5
FIRE PREVENTION	16	WARRANTY	205
FRAME SPRING BUSHINGS	122	WING LIFT CYLINDER	117
GANG PATTERNS	82		
GANG SECTION	114		
GANG SECTIONS	64		
GENERAL ASSEMBLY INFORMATION ..	27		
GENERAL INFORMATION	129		
GENERAL INFORMATION	91		
HARDWARE TORQUE VALUES	200		
HITCH COMPRESSION SPRING	122		
HYDRAULIC CONNECTION SPECIFICATIONS	202		
HYDRAULIC SCHEMATIC (NARROW) ..	198		
HYDRAULIC SCHEMATIC (SUPER NARROW WING)	197		
HYDRAULIC SCHEMATIC (WIDE WING) .	199		
HYDRAULICS	45		
INITIAL SET-UP	94		
LEVELING CRANK	113		
LIGHT KIT	79		
LUBRICATION	110		
OPERATING THE TANDEM DISC	101		
OWNER'S INFORMATION	9		
PURGING / REPHASING HYDRAULIC SYSTEM	63		
ROCKSHAFT SPRING BUSHINGS	123		
SAFETY INSTRUCTIONS	13		
SAFETY SIGN (DECAL) INSTALLATION .	124		
SAFETY SIGN-OFF FORM	24		
SAFETY SIGNS (DECALS)	18		
SCRAPER BARS	123		

Farm King



www.farm-king.com

Farm King

5110 - 62nd Street
Vegreville, Alberta Canada, T9C 1N6
Ph.: 204.822.4467 | Fax: 204.822.6348
Toll Free: 888.524.1004
E-mail: info@buhler.com
www.farm-king.com

Equipment shown is subject to change without notice.
©2016 Buhler Trading Inc. Printed in Canada TSX:BU1

bühler | a division of Buhler Industries Inc.