

bühler

farm king

Conventional Auger Mover

Operator's and Parts Manual
FK375

2009

TABLE OF CONTENTS

DESCRIPTION	PAGE
WARRANTY POLICY	3
INTRODUCTION	4
SAFETY INSTRUCTIONS	5
GENERAL SAFETY INSTRUCTIONS	6
START-UP SAFETY	6
OPERATION SAFETY	6
TRANSPORT SAFETY	7
SERVICE AND MAINTENANCE SAFETY	7
STORAGE SAFETY	8
EXPLODED VIEW OF CONVENTIONAL AUGER MOVER	9
AUGER MOVER PARTS LIST	10
AUGER MOVER PARTS LIST	11
ASSEMBLY INSTRUCTIONS	12
RIGHT DRIVE WHEEL ASSEMBLY	13
EXPLODED VIEW OF DRIVE MOTORS	14
MOVER AXLE ASSEMBLY INSTRUCTIONS	15
MOVER FRAME ASSEMBLY INSTRUCTIONS	16
MOTOR STOP ASSEMBLY	17
WINCH AND OIL TANK EXPLODED VIEWS	18
HYDRAULIC TANK AND WINCH ASSEMBLY INSTRUCTIONS	19
HYDRAULIC PUMP, VALVE, AND HOSE ASSEMBLY	20
EXPLODED VIEW OF HYDRAULIC PUMP MOUNT	21
HYDRAULIC PUMP ASSEMBLY	22
AUGER MOVER OPERATION	23
BELT GUARD ASSEMBLY INSTRUCTIONS	27
CONVENTIONAL AUGER MOVER BELT GUARDS	28
SHIPPING KITS AND BUNDLE NUMBERS	29
NOTES:	30

WARRANTY POLICY

Buhler Manufacturing products are warranted for a period of twelve (12) months (90 days for commercial application) from original date of purchase, by original purchaser, to be free from defects in material and workmanship under correct, normal agricultural use and proper applications.

Buhler Manufacturing's obligations under this warranty shall be limited to the repair or exchange, at Buhler Manufacturing's option, of any Buhler Manufacturing product or part which proves to be defective as provided. Buhler Manufacturing reserves the right to either inspect the product at the buyer's location or have it returned to the factory for inspection.

The above warranty does not extend to goods damaged or subject to accident, abuse or misuse after shipment from Buhler Manufacturing's factory, nor to goods altered or repaired by anyone other than an authorized Buhler Manufacturing representative.

Buhler Manufacturing makes no Express Warranties other than those which are specifically described. Any description of goods, including any references and specifications in catalogues, circulars and other written material published, is for the sole purpose of identifying goods and shall conform to such descriptions. Any sample or model is for illustrative purposes only and does not create an Express Warranty that the goods conform to sample or model shown.

The purchaser is solely responsible for determining suitability of goods sold. This warranty is expressly in lieu of all other warranties expressed or implied. Buhler Manufacturing will in no event be liable for any incidental or consequential damages whatsoever. Nor for any sum in excess of the price received for the goods for which liability is claimed.

WARRANTY CLAIMS:

Warranty requests must be prepared on Buhler Manufacturing Warranty Claim Forms with all requested information properly completed. Warranty Claims must be submitted within a thirty (30) day period from date of failure repair.

WARRANTY LABOR:

Any labor subject to warranty **must** be authorized by Buhler Manufacturing. The labor rate for replacing defective parts, where applicable, will be credited at 100% of the dealer's posted shop rate. Defective parts will receive an extra 10% discount to assist with freight or other incidental costs.

GOVERNMENT LEGISLATION:

Warranty terms and conditions are subject to Provincial or State legislation.

IMPORTANT FACTS:

Buckets and Bucket Tines Carry No Warranty
Bent Spears Carry No Warranty
Snowblower Fan Shafts Carry No Warranty
Mower Blades Carry No Warranty
Portable Auger Parts Have Two (2) Year Warranty
Loader Parts Have Two (2) Year Warranty

IMPORTANT NOTE: This warranty does not apply to rentals

INTRODUCTION

The Buhler Farm King conventional auger mover is an option that attaches to an auger and allows you to transfer the weight from the intake onto a swivel yoke. This makes moving the auger and positioning it at a bin a much lighter task, which can be done by one person. There are two sizes available. The small mover fits 31', 36', 41', and 46' augers. The large mover fits 51', 56', and 61' augers.

Keep this manual handy for frequent reference. All new operators or owners must review the manual before using the equipment and at least annually thereafter. Contact your Buhler Dealer if you need assistance, information, or additional copies of the manual. Visit our website at www.buhler.com for a complete list of dealers in your area.

The directions left, right, front and rear, as mentioned throughout this manual, are as seen facing in the direction of travel of the implement.

SAFETY INSTRUCTIONS

Remember, **YOU** are the key to safety. Good safety practices not only protect you, but also the people around you. Make these practices a working part of your safety program. Be certain that everyone operating this equipment is familiar with the recommended operating and maintenance procedures and follows all the safety precautions. Most accidents can be prevented. Do not risk injury or death by ignoring good safety practices.

The alert symbol is used throughout this manual. It indicates attention is required and identifies hazards. Follow the recommended precautions.



The safety alert symbol means...

ATTENTION! BECOME ALERT! YOUR SAFETY IS INVOLVED!



CAUTION

The caution symbol indicates a potentially hazardous situation that, if not avoided, may result in minor or moderate injury. It may also be used to alert against unsafe practices.



WARNING

The Warning Symbol indicates a potentially hazardous situation that, if not avoided, could result in death or serious injury, and includes hazards that are exposed when guards are removed. It may also be used to alert against unsafe practices.



DANGER

The Danger Symbol indicates an imminently hazardous situation that, if not avoided will result in death or serious injury. This signal word is to be limited to the most extreme situations, typically for machine components that, for functional purposes, cannot be guarded.

GENERAL SAFETY INSTRUCTIONS

Have a first-aid kit available for use and know how to use it.

Have a fire extinguisher available, stored in a highly visible location, and know how to use it.

Wear appropriate protective gear. This list may include but is not limited to:

- Hard hat
- Protective shoes with slip resistant soles
- Protective glasses or goggles
- Heavy gloves
- Wet weather gear
- Hearing protection
- Respirator or filter mask

Read and understand the Operator's Manual and all safety signs before operating, servicing, adjusting, repairing, or unplugging the equipment.

Do not attempt any unauthorized modifications to your Buhler product as this could affect function or safety, and could affect the life of the equipment.

Inspect and clean the working area before operating.

Keep hands, feet, clothing, and hair away from moving parts.

Ensure bystanders are clear of the area before operating.

START-UP SAFETY

Do not let inexperienced operators or children run this equipment.

Place all tractor and machine controls in neutral before starting.

Operate only with ROPS and seatbelt equipped tractors.

Do not operate inside a building unless there is adequate ventilation.

Ensure all shields are in place and in good condition before operating.

Stay clear of PTO shaft and machine when engaging PTO.

The auger must be on a level surface and wheels free to move when raising or lowering. Everyone should be kept clear during these operations.

Make certain electric motors are grounded.

OPERATION SAFETY

Do not permit riders.

Do not wear loose fitting clothing during operation.

Empty the auger before moving to prevent upending.

Do not allow anyone other than the operator close to the Auger when in operation.

Never stand under the auger while raising or lowering.

When filling tall bins, tanks, or granaries, it is advisable to anchor the auger to the bin or building to prevent it from being tipped over by the wind or a sudden movement. Never operate a Conventional Auger with the intake end off the ground.

Never operate over 540 PTO rpm speed.

Never raise the intake end of the auger above waist high, as the balance shifts forward, and the auger will tip over.

Stay away from overhead obstructions and power lines during operation and transporting. Electrocution can occur without direct contact.

TRANSPORT SAFETY

Review Transport Safety instructions in tractor manual before moving.

Check with local authorities regarding transport on public roads. Obey all applicable laws and regulations.

Do not tow equipment that does not have brakes at speeds over 32km/h (20 mph).

Do not tow equipment that does not have brakes that, when fully loaded, has a mass (weight) over 1.5 t (3300 lb) and more than 1.5 times the mass (weight) of the towing unit.

Make sure the SMV (Slow Moving Vehicle) emblem and all the lights and reflectors that are required by the local highway and transport authorities are in place, are clean, and can be seen clearly by all overtaking and oncoming traffic.

Never have the equipment in operation during transport.

Always transport the Conventional Auger Mover in the transport position, carrying the weight of the auger mover on the safety chain.

Take extreme caution in maneuvering on or around tight corners so as not to catch the end of the auger on trees, buildings, power lines, etc.

The equipment should never be towed without the safety chain securely attached to the auger and the towing vehicle.

When moving the auger on the road, always use a red flag, or if absolutely necessary to move at night, accessory lights for adequate warning to operators of other vehicles.

Always travel at a safe speed.

Inflate transport tires to recommended pressure.

SERVICE AND MAINTENANCE SAFETY

Stop engine, set brake, remove ignition key, and wait for all moving parts to stop before servicing, adjusting, repairing, or unplugging.

Support the equipment with blocks or safety stands before working beneath it.

Follow good shop practices including

- Keep service area clean and dry
- Be sure electrical outlets and tools are properly grounded
- Use adequate light for the job

Use only tools, jacks, and hoists of sufficient capacity for the job.

Replace and secure all shields removed during servicing before operating.

Use heavy leather gloves to handle sharp objects.



Failure to follow proper procedures when mounting a tire on a wheel or rim can produce an explosion, which may result in serious injury or death.

STORAGE SAFETY

Store the unit in an area away from human activity.
 Do not permit children to play on or around the stored machine.
 Support the frame on stands and blocks to provide a secure base.
 When storing an auger, park it on level ground so that the bottom end will never be over its center of gravity.
 Block the wheels of the auger so that the auger will not move.
 When storing the auger, the intake end should be tied or weighted to prevent tipping.

WHEN ORDERING PARTS

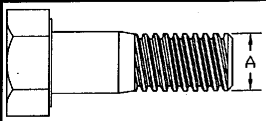
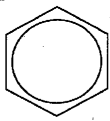
Always give your dealer the Model and Serial Number of your machine to assist him in ordering and obtaining the correct parts. Use the exploded view and tabular listing of the area of interest to exactly identify the required part.

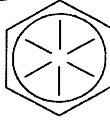
Bolt Torque						
						
Bolt Diameter	SAE2		SAE5		SAE8	
"A"	N.m	lb-ft	N.m	lb-ft	N.m	lb-ft
1/4"	8	6	12	9	17	12
5/16"	13	10	25	19	36	27
3/8"	27	20	45	33	63	45
7/16"	41	30	72	53	100	75
1/2"	61	45	110	80	155	115
9/16"	95	70	155	115	220	165
5/8"	128	95	215	160	305	220
3/4"	225	165	390	290	540	400
7/8"	230	170	570	420	880	650
1"	345	225	850	630	1320	970

EXPLODED VIEW OF CONVENTIONAL AUGER MOVER

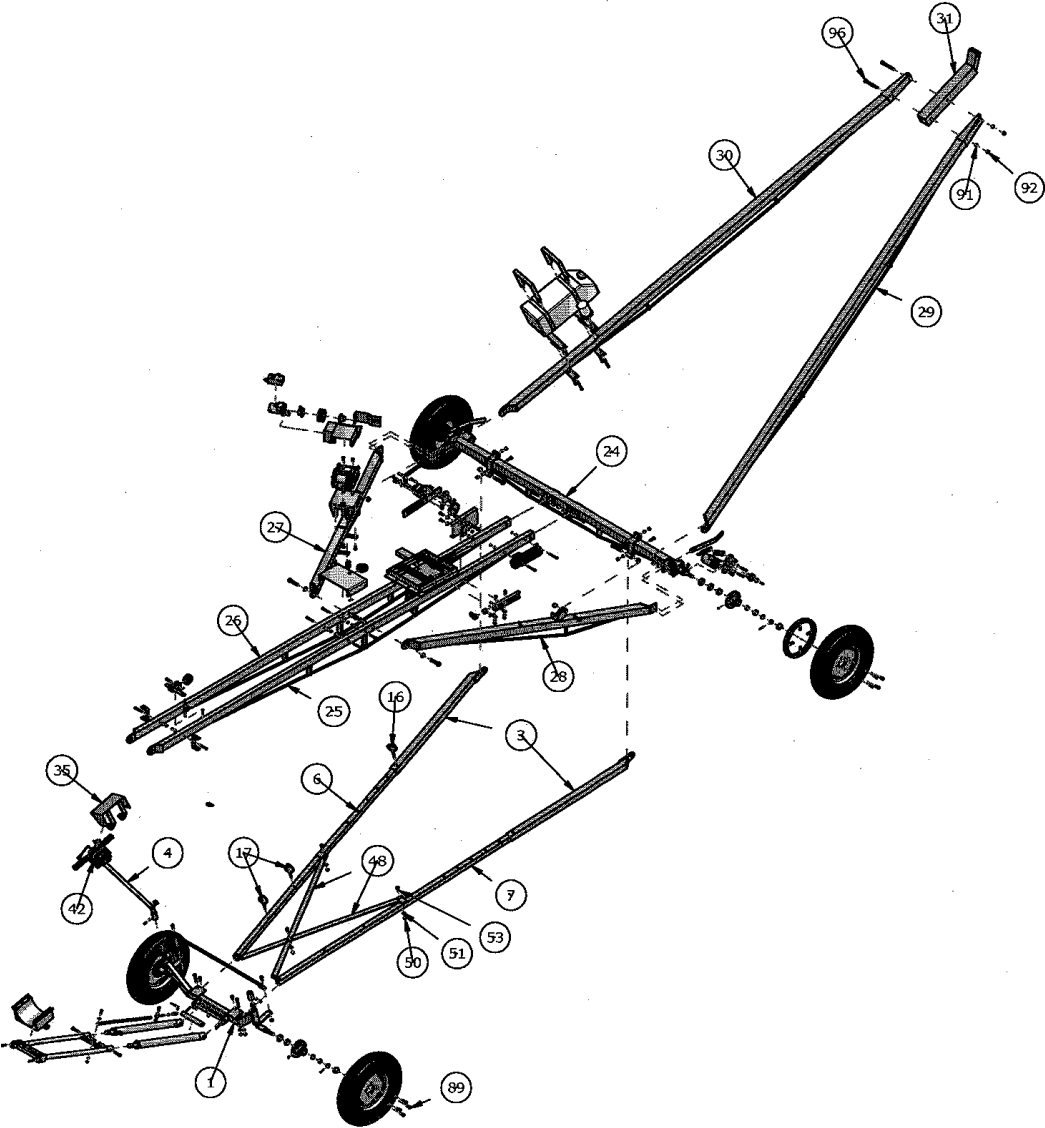

AUGER MOVER PARTS LIST

1	910160	AXLE WELDT (LG MVR)	1	65	910120	3/8" X 4" X 6 3/4" HYD MOT MT PL	2
	910106	AXLE WELDT (SM MVR)	1	66	910119	HYD MOT ARM	2
2	910161	LIFT ARM WELDT (LG MVR)	1	67	910271	3/8" X 2" X 4 1/2" TANK MT PL	2
	910107	LIFT ARM WELDT (SM MVR)	1	68	903392	1/4" X 1 1/4" X 9 1/8" CLEV HLDR	2
3	910162	UNDERCARR ADJMENT TUBE WELDT (LG MVR)	2	69	961846	1/2"ID X 3 1/2"OD X 1 1/8" CBLE PULLEY	2
	910108	UNDERCARR ADJMENT TUBE WELDT (SM MVR)	2	70	903413	8 1/4" X 19 1/2" WNCH BRKT	1
4	910163	VLE MT & STEERING HNDL WELDT (LG MVR)	1	71	903414	3/8" X 1 1/4" X 5 1/4" CONN PL	2
	910116	VLE MT & STEERING HNDL WELDT (SM MVR)	1	72	968430	OIL SEAL SE14X	2
5	910164	ADJABLE TUBE WELDT (LG MVR)	1	73	967208	INNER BEARING CONE (967208 (LM48548)	2
	910141	ADJABLE TUBE WELDT (SM MVR)	1	74	968403	5-BOLT HUB W/BEARING CUPS	2
6	910165	ADJMENT TUBE WELDT - L (LG MVR)	1	75	967900	1/4" GREASE FITTING	2
	910142	ADJMENT TUBE WELDT - L (SM MVR)	1	76	968406	OUTER BEARING CONE LM11949	2
7	910166	ADJMENT TUBE WELDT - R (LG MVR)	1	77	968405	BEARING CUP (LM11910)	2
	910143	ADJMENT TUBE WELDT - R (SM MVR)	1	78	9812416	3/4" SAE FLAT WASHER (BR)	2
8	25480	AUG CYL ASSY (LG MVR)	2	79	81834	3/4" SLOTTED HEX NUT	2
	25481	AUG CYL ASSY (SM MVR)	2	80	9812486	1/8" X 1 1/2" COTTER PIN (BR)	2
9	910091	CYL SPACER WELDT	1	81	968409	DUST CAP	2
10	910140	SUPPORT CLAMP WELDMENT	2	82	81638	1/2" BS FLAT WASHER (PL)	10
11	910257	HUB & STUB AXLE ASSY - L (LG MVR)	1	83	81624	1/2" X 2 1/4" HEX BOLT (PL)	2
	910215	STEER WELDT - L (SM MVR)	1	84	910204	CAST PINION GEAR	2
12	910261	HUB & STUB SHFT ASSY - R (LG MVR)	1	85	910196	RING GEAR CAST W/ SETSCREWS	2
	910144	STEER WELDT - R (SM MVR)	1	86	81593	3/8" LOCK WASHER (PL)	25
13	910195	10" MVR CLP WELDT	1	87	86171	3/8" X 1 1/4" HEX BOLT (PL)	7
14	910117	COUPLER WELDMENT	1	88	81592	3/8" HEX NUT (PL)	24
15	910115	ADJUSTMENT ROD WELDMENT	1	89	968404	1/2" X 1 1/4" WHEEL BOLT (PL)-INCLUDED W/ HUB	18
16	910238	HOSE GUIDE WELDT (1/2" BOLT)	1	90	84270	5/8" X 1 3/4" HEX BOLT (PL)	4
17	910239	HOSE GUIDE WELDT (3/8" BOLT)	2	91	81677	5/8" LOCK WASHER (PL)	9
18	971518	HYD MOTOR 101-1018	1	92	81676	5/8" HEX NUT (PL)	8
19	909169	MANIFOLD	1	93	81583	3/8" X 3" HEX BOLT (PL)	6
20	910202	10 MICRON OIL FILTER	1	94	961010	1/2" X 2 1/8" CLEV PIN	2
21	F253	TIRE MOUNTED 6.70	2	95	9812430	1/8" X 1" COTTER PIN (PL)	2
22	910139	HYDRAULIC WINCH GUARD WELDMENT	1	96	81674	5/8" X 5 1/2" HEX BOLT (PL)	2
23	910134	HYDRAULIC WINCH ADAPTOR WELDMENT	1	97	81669	5/8" X 3 1/2" HEX BOLT (PL)	2
24	962039	AXLE WELDT	1	98	86170	3/8" X 1" HEX BOLT PL	12
25	F0718	UNDERCARR WELDT - L	1	99	84000	3/8" FLAT WASHER (PL)	3
26	F8851	UNDERCARR WELDT - R	1	100	84346	3/4" X 2 1/2" HEX BOLT (PL)	2
27	903416	X TUBE WELDT - R	1	101	810640	5/16" X 2" HEX BOLT (PL)	2
28	962035	X TUBE WELDT - L	1	102	81569	5/16" LOCK WASHER PL	4
29	F8852	LIFT ARM WELDT - L	1	103	81568	5/16" HEX NUT PL	4
30	F8853	LIFT ARM WELDT - R	1	104	810149	3/4" X 3 1/2" HEX BOLT (PL)	2
31	962043	LIFT ARM EXT WELDT	1	105	81702	3/4" BS FLAT WASHER (PL)	2
32	910267	TANK STRAP WELDT	2	106	81700	3/4" HEX NUT (PL)	2
33	910272	TANK MT WELDT	1	107	812744	5/16" X 3 1/2" HEX BOLT (PL)	2
34	910273	TANK & OIL FILTER MT WELDT	1	108	81701	3/4" LOCK WASHER (PL)	2
35	910198	CTRL DISPLAY WELDT	1	109	81588	3/8" X 4 1/2" HEX BOLT (PL)	4
36	908010	MOT MT WELDT	1	110	81525	1/4" X 3/4" HEX BOLT (PL)	2
37	962060	IDLER MTG PL WELDT	1	111	81545	1/4" LOCK WASHER (PL)	2
38	961333	SWVL PULLEY HLDR WELDT	1	112	904590	1/4" X 4 1/4" X 5" HNGR MTG BRKT	2
39	961945	K2550 WINCH	1	113	961377	Ø1" X 10 1/2" HNGR SWVL SHFT	1
40	910131	MOTOR CONNECTOR WELDMENT	2	114	968412	INNER CUP (LM48510)	2
41	909277	MANUAL HOLDER 3 1/2" X 12"	1	115	84111	1/2" X 1 1/4" SQ HD SET SCREW (PL)	4
42	910275	VALVE MOUNT AND STEERING HANDLE	1	116	910126	HYDRAULIC PUMP TO MOTOR CONNECTOR	1
43	961375	HNGR WELDT	1	117	910213	HYD PUMP ARM	1
44	910130	PUMP HANDLE WELDMENT	1	118	910128	PUMP BELT GUARD MOUNT PLATE	1
45	910100	UPPER LIFT PIN	1	119	910129	PUMP BELT GUARD	1
46	910101	LOWER LIFT PIN	1	120	910127	PUMP BELT GUARD SPACER	1
47	910075	MOVER CLAMP PLATE	2	121	910123	PUMP BELT TENSIONER LINK PLATE	1
48	910152	1/4" X 1 3/4" X 60" X BRACE	2	122	910200	26004-LZD HYD PUMP	1
49	910214	TAPERED BEARING T126	2	123	910199	SGL GRV 4 1/2" SHEAVE C/W HUB	1
50	81636	1/2" HEX NUT (PL)	25	124	84289	5/8" X 3" HEX BOLT (PL)	1
51	81637	1/2" LOCK WASHER (PL)	22	125	81615	7/16" LOCK WASHER (PL)	4
52	87553	1/2" X 1 3/4" HEX BOLT (PL)	4	126	81614	7/16" HEX NUT (PL)	4
53	81620	1/2" X 1 1/4" HEX BOLT PL	5	127	81598	7/16" X 1 1/4" HEX BOLT (PL)	4
54	811796	1/2" 2 1/2" HEX BOLT (PL)	2	128	81578	3/8" X 1 3/4" HEX BOLT (PL)	2
55	84336	3/4" X 4" HEX BOLT (PL)	2	129	910245	HYD MOTOR 101-1011-009	2
56	812365	3/4" LOCK NUT (PL)	4	130	910179	STOPPER WELDT	1
57	81629	1/2" X 3 1/2" HEX BOLT (PL)	2	131	910180	MOT STOP FRAME WELDT	1
58	812037	Ø3/8" X 3/4" SQHDCUP SETSCREW (PL)	2	132	910181	SETSCREW WELDT	1
59	986045	3/8" JAM NUT (PL)	2	133	910175	1.017"ID X 1 1/2"OD X 1" MOT STOP ADJABLE PIPE	1
60	9812434	1/4" X 1 1/2" COTTER PIN (PL)	6	134	81544	1/4" HEX NUT (PL)	1
61	84277	1/2" X 1 1/2" HEX BOLT (PL)	5	135	81528	1/4" X 1 1/4" HEX BOLT (PL)	1
62	812364	1/2" LOCK NUT (PL)	2	136	811631	1/4" X 1 1/2" HEX BOLT GR5 (PL)	2
63	910203	10" X 10" X 25" HYD OIL TANK	1	137	Washer	1/4" FLAT WASH (PL)	2

AUGER MOVER PARTS LIST

#	PART #	DESCRIPTION	QTY
153	Double Chain		1
154	Chain Gear with Setscrews		2
155	905043	CLEVIS YOKE W/ PIN & COT PIN	1
156	910240	AXLE HLD R CHAIN	1
157	903590	CHAIN TGH TNR ROD WELDT	1
138	Spring		2
158	812363	3/8" LOCK NUT (PL)	3
159	81570	5/16" FL WASH (PL)	2
160	910212	OIL FILTER HEAD	1

ASSEMBLY INSTRUCTIONS**WHEEL DRIVE INSTALLATION INSTRUCTIONS**

1. Page 9: Jack up one end of the auger axle (#24) and remove the wheel and tire assembly.
2. Page 7: Take one of the wheel drive gears (#84) and place it into the inside of the rim with the gear facing out. Use a straight edge placed at several positions across the tire to line up the gear.
3. With the gear lined up, fasten it to the rim using four 5/16" x 1/2" socket set screws. These must be tightened in several stages switching from side to side so the gear stays in position. These must be securely tightened to prevent the gear from popping out under load. Bolt the rim back onto the auger.
4. Now take the drive assembly with the hydraulic motor and slide it onto the axle. The assemblies are left and right. The handle should face the outside of the axle and the drive gear should be facing down. The hydraulic ports on the motor should face up. It is **VERY IMPORTANT** the motor gear is parallel with the wheel drive gear and that both gears contact along their full length.
5. Tack the hydraulic motor arm (#66) on the drive assembly to the axle. Double check for alignment and weld solid.
6. Insert two 7/8" MORB x 9/16" MJIC 90° elbows (#7 hydraulic fittings) into the motor ports. Tighten so ends face center of the axle.
7. Repeat on the other wheel.
8. If the motor gear is not engaged far enough into the wheel drive gear, the bottom of the handle is slotted for adjustment.

RIGHT DRIVE WHEEL ASSEMBLY

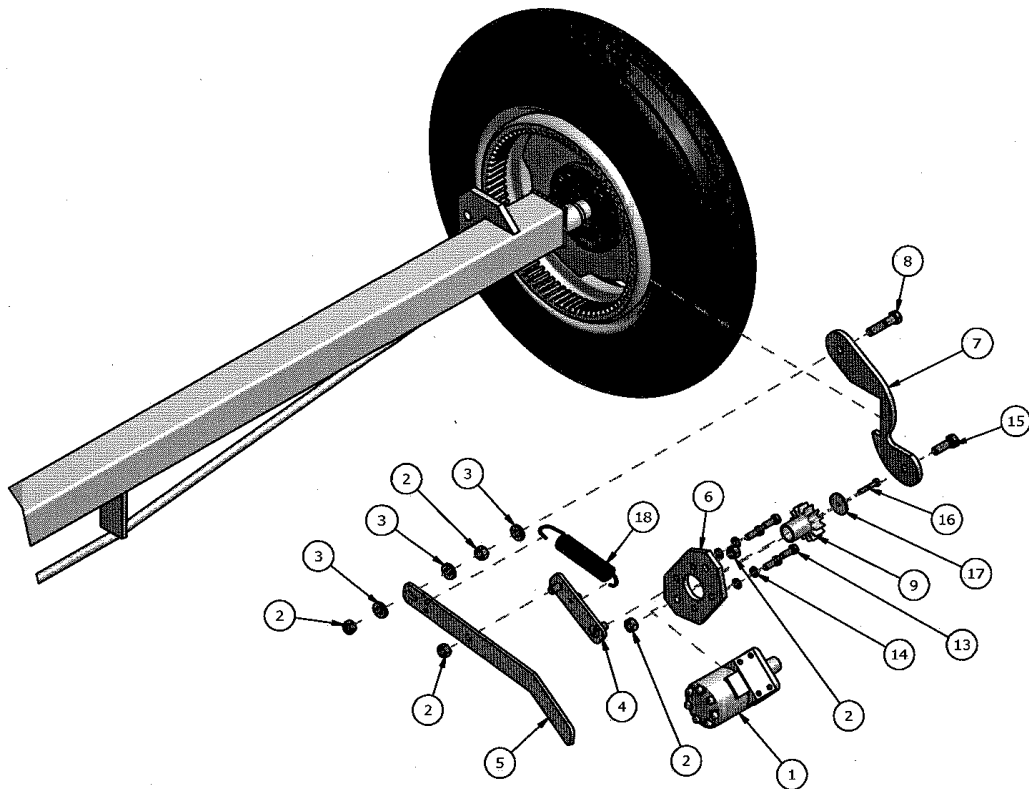

18	Spring		2
17	Washer	1/4" FLAT WASH (PL)	2
16	811631	1/4" X 1 1/2" HEX BOLT GR5 (PL)	2
15	84277	1/2" X 1 1/2" HEX BOLT (PL)	2
14	81593	3/8" LOCK WASHER (PL)	8
13	86170	3/8" X 1" HEX BOLT PL	8
12	81676	5/8" HEX NUT (PL)	1
11	81677	5/8" LOCK WASHER (PL)	1
10	84270	5/8" X 1 3/4" HEX BOLT (PL)	1
9	910204	CAST PINION GEAR	2
8	81624	1/2" X 2 1/4" HEX BOLT (PL)	2
7	910119	HYD MOT ARM	2
6	910120	3/8" X 4" X 6 3/4" HYD MOT MT PL	2
5	910121	MOTOR HANDLE	2
4	910131	MOTOR CONNECTOR WELDMENT	2
3	81638	1/2" BS FLAT WASHER (PL)	6
2	81636	1/2" HEX NUT (PL)	10
1	910245	HYD MOTOR 101-1011-009	2
#	PART #	DESCRIPTION	QTY

EXPLODED VIEW OF DRIVE MOTORS

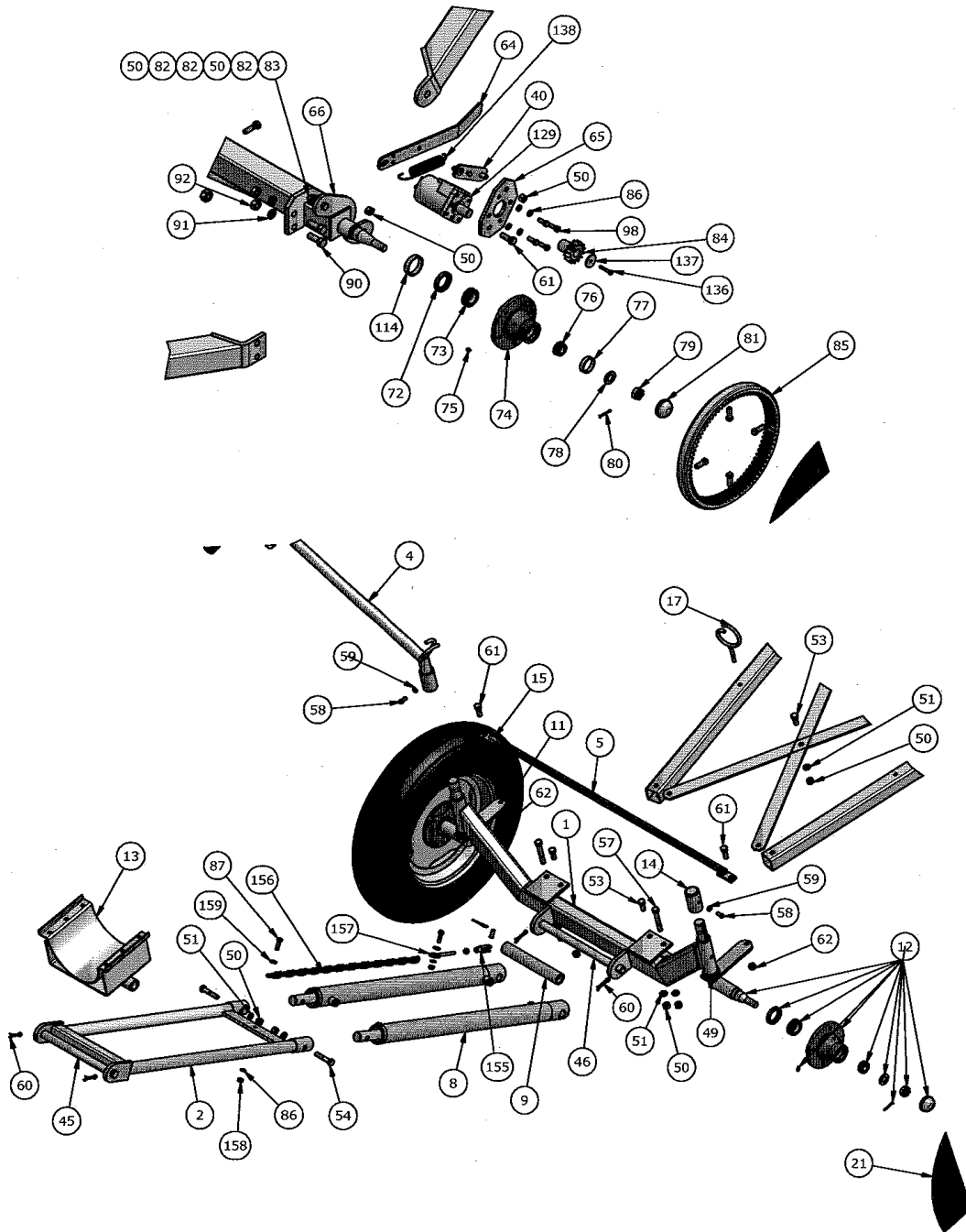

MOVER AXLE ASSEMBLY INSTRUCTIONS

1. Be sure to install the grease nipples in the tubes at both ends of the axle assembly before mounting the tires. Insert the left hand (#11) and the right hand (#12) hub and spindle assemblies through the tubes at the ends of the axle, check to see that they are turned as shown in the drawing.
2. The right hand spindle has a coupler (#14) pushed onto the shaft protruding through the sleeve. It is held in place by a 3/8" x 3/4" set screw and jam nut in the shaft groove.
3. Take the valve mount and steering handle weldment and insert it onto the shaft of the left hand spindle using a 1/4" x 2" key. Hold in place with a set screw and jam nut in the shaft groove.
4. Mount the wheels and tires on the spindle hubs using the nuts supplied with the hubs. Bolt the steering tube (#5) to the lever on the right hand spindle (#12) using a 1/2" x 1 1/2" bolt and lock nut. The other end of the tube has a threaded adjustment rod. Adjust the threaded rod until the wheels are parallel. Do not over tighten lock nuts because parts must turn freely.

MOVER FRAME ASSEMBLY INSTRUCTIONS

1. Slide the left and right adjustment tubes (#6 & #7) into the two outer tubes (#3). The connecting hole you use will vary with the length of the auger. For the small mover use the tubes fully extended on 46' augers and fully collapsed on 31' augers. Sizes between these lengths will use a hole between these two positions. For the large mover use the tubes fully extended on 61' augers and fully collapsed on 51' augers. Turn adjustment tubes so brace bracket is on the inside. The inner and outer tubes are joined by a hose guide weldment (#16) with a 1/2" bolt on the left hand side. A 1/2" x 3 1/2" bolt, lock washer and hex nut is used on the right hand side. Two additional hose guides with a 3/8" bolt (#17) are spaced along the left adjustment tube (#6).
2. Bolt the ends of the tube assemblies between the brackets welded to the side of the mover axle assembly (#1) using 1/2" x 3 1/2" bolts, lock washers and hex nuts. The two cross braces (#48) join the two tube assemblies. One end bolts to the axle and the other end to the welded bracket on the tube. Join where they cross. Use 1/2" x 1 1/4" bolts, lock washers and hex nuts at all five locations.
3. Loosely assemble the mover clamp plates (#47) and the support clamp weldments (#10) on the main auger axle using 1/2" x 3/4" bolts, lock washers and hex nuts. Space them so they are centered on the axle and about the same distance apart as the ends of the tube assemblies. The welded tube on the support clamp weldment is turned down and faces the inside of the auger. The ends of the axle tubes bolt to the outsides of the clamp tubes using a 3/4" x 4" bolt and lock nut. Tighten so this connection can still move freely. Verify that the two clamp assemblies are accurately centered and then tighten bolts.
4. Connect the two hydraulic cylinders (#8) to the mover axle (#1) using the lower lift pin (#46). The cylinders are turned with the ports facing in. The ends of the cylinders and a cylinder spacer weldment (#9) are fitted on the pin between two welded brackets on the mover axle. The lift arm weldment (#2) slides onto the ends of the cylinders and is held on by two 1/2" x 2 1/2" bolts, lock washers and hex nuts. The tube clamp weldment (#13) connects to the end of the lift arm with the upper lift pin (#45). Both pins are held in place by 1/4" x 1 1/2" cotter pins (#60).
5. Before bolting the clamp to the tube, extend the hydraulic cylinders about 1 1/2". This will make the tires for the mover lift when the cylinder is fully compressed for transport. Bolt the clamp to the tube using 3/8" x 2" bolts, lock washers and hex nuts. Clamp position will be checked when assembly is complete.
6. Connect the transport chain when the mover is lifted up in transport position. Bolt one end to the lift arm (#2) and the other end to the threaded chain tightener. Use 3/8" x 1 1/4" bolts, lock washers and hex nuts. Use the clevis and the threaded rod to adjust to the correct length when in transport position. DO NOT forget to remove this chain before using the mover.

MOTOR STOP ASSEMBLY

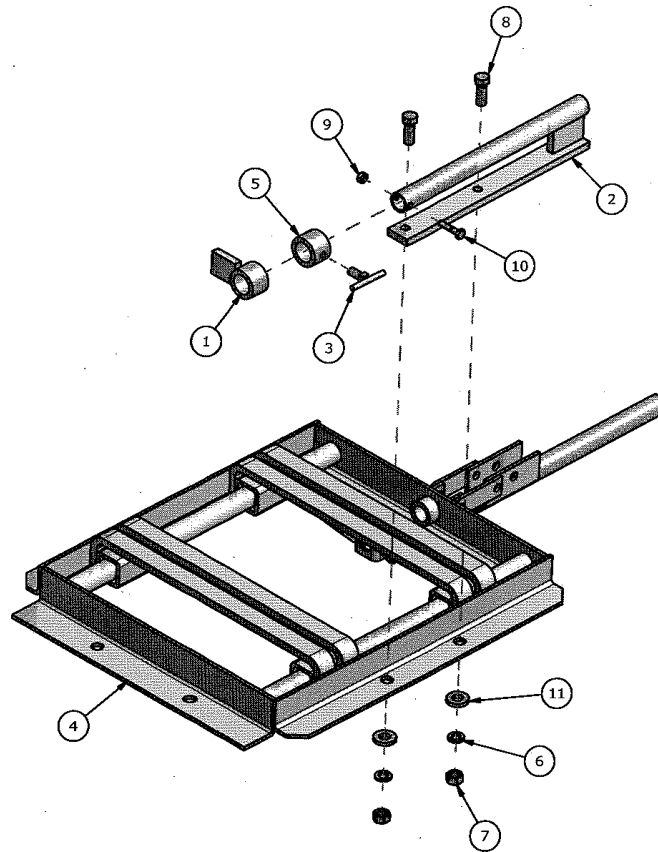

11	81638	1/2" BS FLAT WASHER (PL)	2
10	81528	1/4" X 1 1/4" HEX BOLT (PL)	1
9	81544	1/4" HEX NUT (PL)	1
8	81598	7/16" X 1 1/4" HEX BOLT (PL)	2
7	81614	7/16" HEX NUT (PL)	2
6	81615	7/16" LOCK WASHER (PL)	2
5	910175	1.017"ID X 1 1/2"OD X 1" MOT STOP ADJABLE PIPE	1
4	908010	MOT MT WELDT	1
3	910181	SETSCREW WELDT	1
2	910180	MOT STOP FRAME WELDT	1
1	910179	STOPPER WELDT	1
#	PART #	DESCRIPTION	QTY

WINCH AND OIL TANK EXPLODED VIEWS

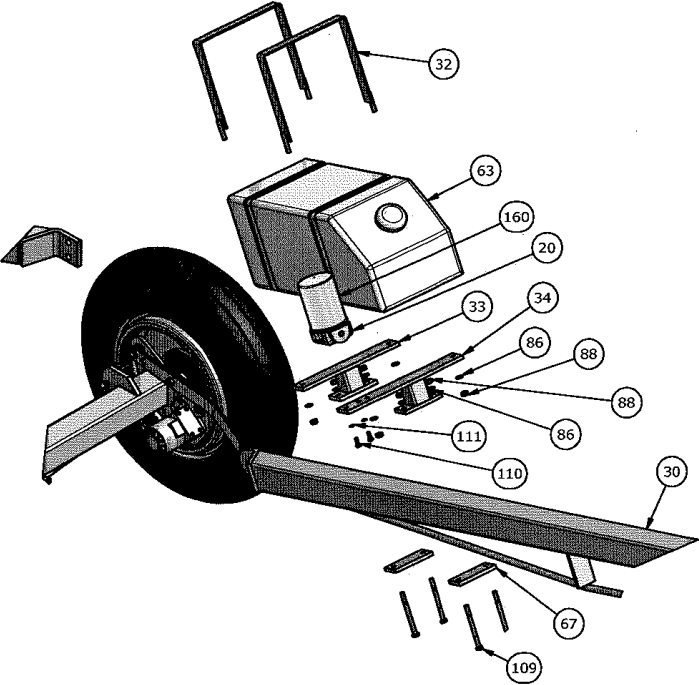
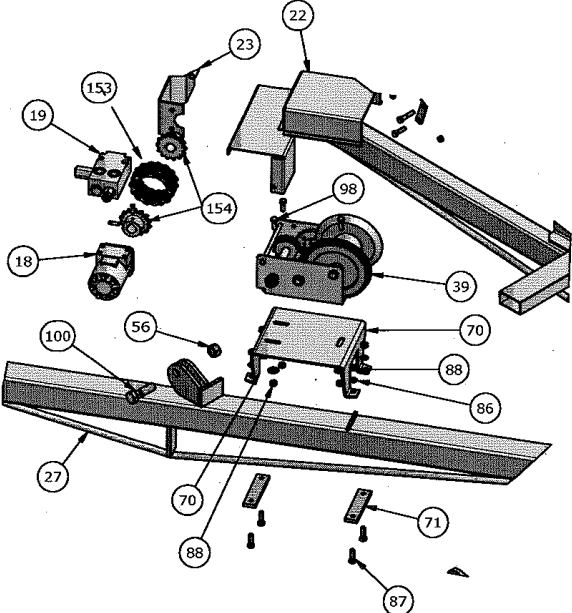

HYDRAULIC TANK AND WINCH ASSEMBLY INSTRUCTIONS

1. The hydraulic oil tank bolts to the right hand undercarriage arm just above the motor mount. Turn tank so filler cap faces up. Position so the 3/4" hose will be long enough to reach from the end of the tank to the hydraulic pump behind the gas motor. Fit the two tank strap weldments into the grooves on the tank and bolt on the two stands (#33 & #34). One stand (#34) has extra holes for mounting the oil filter. These holes face the outside of the auger. Use 3/8" lock washers and hex nuts. Bolt the stands to the undercarriage arm using two 4 1/2" long clamp plates (#67) and 3/8" x 4 1/2" bolts, lock washers and hex nuts.
2. The winch bracket (#70) should be in place on the auger before starting. The rest of the winch drive assembly can be assembled before bolting to the winch bracket. Remove the long bolt from the top corner of the winch and replace it after sliding it through the welded sleeve on the winch adaptor weldment (#23). Bolt the manifold (#19) to the hydraulic motor (#18) using four 5/16" x 2" socket head bolts. Join the winch shaft using a 3/16" sq. x 1" key and the hydraulic motor using a woodruff key in the motor with the chain coupler. Tighten set screws in coupler when in place. Bolt the winch adaptor weldment to the hydraulic motor using two 3/8" x 3/4" bolts and lock washers. The winch guard weldment (#22) bolts to the edge of the winch with a 1/4" x 3/4" bolt, lock washer and hex nut and to the motor with a 3/8" x 3/4" bolt and lock washer. To tighten the bolts on the chain coupler cover, first tighten one side and then turn the winch one half turn with a wrench to tighten the other side. Bolt this assembly to the winch bracket and attach the cable.

HYDRAULIC PUMP, VALVE, AND HOSE ASSEMBLY

1. Bolt the motor stop to the side of the motor mount. Slide on the stop tube with the set screw first (#133 & #132). Then slide on the stop weldment (#130). A 1/4" x 1 1/4" bolt and hex nut at the end stop them from sliding off. Bolt the pump assembly (#122) to the side of the gas motor using slots in the connector bar (#116).
2. Bolt the control valve (#42) to the top of the steering handle (#4) using 5/16" x 2 3/4" bolts, lock washers and hex nuts. The cover with the decal for control directions can be added after fittings and hoses are in place. The correct fittings are shown on the drawing labeled hydraulic fittings. Note that one of the ports has a ball valve. This valve acts as a safety mechanism so the winch cannot be accidentally activated. The winch has a pressure relief valve so the hoses must be connected to the correct ports. Check hydraulic system drawing to verify.
3. Install the rest of the fittings as shown on the hydraulic fittings drawing. The base for the oil filter holder will require 3/4" to 1/2" reducer bushings that are not shown on this drawing.
4. There are two separate drawings showing the hose connections for the small and the large mover. About half the hoses are equal lengths on both sizes of movers. Run the long hoses through the hose guides on the mover tubing. On some shorter sizes you will have to roll up excess length of hose. Use cable ties to fasten any hoses that hang down to the axle or mover tubing.

HYDRAULIC PUMP ASSEMBLY

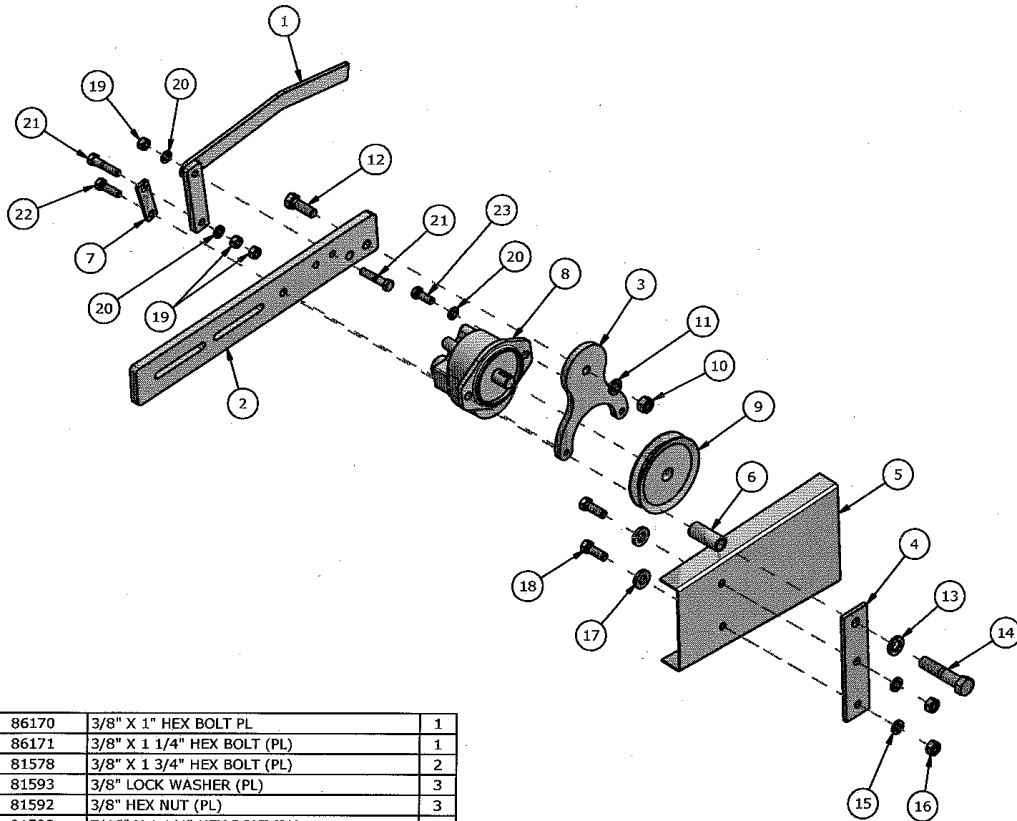

23	86170	3/8" X 1" HEX BOLT PL	1
22	86171	3/8" X 1 1/4" HEX BOLT (PL)	1
21	81578	3/8" X 1 3/4" HEX BOLT (PL)	2
20	81593	3/8" LOCK WASHER (PL)	3
19	81592	3/8" HEX NUT (PL)	3
18	81598	7/16" X 1 1/4" HEX BOLT (PL)	2
17	81638	1/2" BS FLAT WASHER (PL)	2
16	81614	7/16" HEX NUT (PL)	2
15	81615	7/16" LOCK WASHER (PL)	2
14	84289	5/8" X 3" HEX BOLT (PL)	1
13	81677	5/8" LOCK WASHER (PL)	1
12	84277	1/2" X 1 1/2" HEX BOLT (PL)	1
11	81637	1/2" LOCK WASHER (PL)	1
10	81636	1/2" HEX NUT (PL)	1
9	910199	SGL GRV 4 1/2" SHEAVE C/W HUB	1
8	910200	26004-LZD HYD PUMP	1
7	910123	PUMP BELT TENSIONER LINK PLATE	1
6	910127	PUMP BELT GUARD SPACER	1
5	910129	PUMP BELT GUARD	1
4	910128	PUMP BELT GUARD MOUNT PLATE	1
3	910213	HYD PUMP ARM	1
2	910126	HYDRAULIC PUMP TO MOTOR CONNECTOR	1
1	910130	PUMP HANDLE WELDMENT	1
#	PART #	DESCRIPTION	QTY

AUGER MOVER OPERATION

1. Once your fittings are tight you can fill your reservoir with hydraulic oil. Any hydraulic oil will work.
2. Tighten down your winch cable and make sure there are three full wraps around the drum before tension is added.
3. The relief valve bolted to the winch hydraulic motor should be adjusted before using, if required. The power is adjusted on the control screw on the side of the solenoid valve. The factory setting is 3 turns out. There should be just enough power to lift the empty intake auger off the ground. Remove the plug and adjust with an Allen wrench if required. The winch speed is adjusted with a control screw on the end of the solenoid valve. The factory setting is 3 1/2 turns out. If speed adjustment is required, loosen the hex nut on the threaded shaft and adjust with an Allen wrench as required. Lock the setting in place with the hex nut.

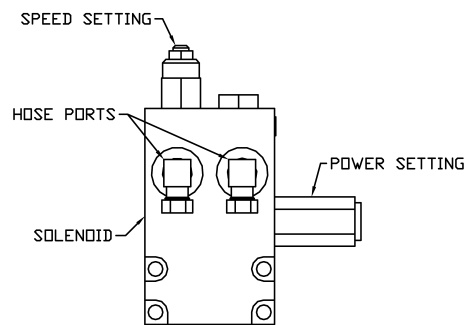

MD-20

4. Grease the sleeves on the wheel spindles.
5. Make sure all bolts are tight and pins are secure.
6. Check the air pressure in the tires.
7. Check engine oil.
8. Start the engine at a low rpm and then activate the control valve. If the direction of movement is not the same as shown on the valve cover decal, invert the hoses on that spool.
9. The wheel speed can be adjusted on the divider block at the center of the axle. Loosen nut and adjust with an Allen wrench.
10. Check all hydraulic fittings for leaks.
11. Lift cylinders slowly up and down to check for any binding in the hoses.
12. Always use safety chain when transporting. Do not forget to remove when using conventional auger mover.

Conventional Auger Mover (Hydraulic Fittings)		
ITEM	PART #	DESCRIPTION
1	910262	9/16" MORB x 9/16" MJIC 90° Elbow w/restrictor
2	887572	9/16" FJIC x 9/16" MJIC x 9/16" MJIC Tee
3	812304	9/16" MORB x 9/16" MJIC 45° Elbow
4	811414	3/4" MORB x 3/4" MJIC 90° Elbow
5	910247	3/8" Steel Ball Valve 200 WoG
6	812084	3/8" MNPT x 9/16" MJIC Adaptor Straight
7	812457	7/8" MORB x 9/16" MJIC 90° Elbow
8	886897	7/8" MORB x 3/4" MJIC Adaptor Straight
9	905392	3/4" MORB x 3/4" FORB 90° Elbow
10	812079	3/4" MORB x 1/2" SWFNPT Adaptor Straight
11	910249	9/16" FJIC x 3/8" MNPT Adaptor Straight

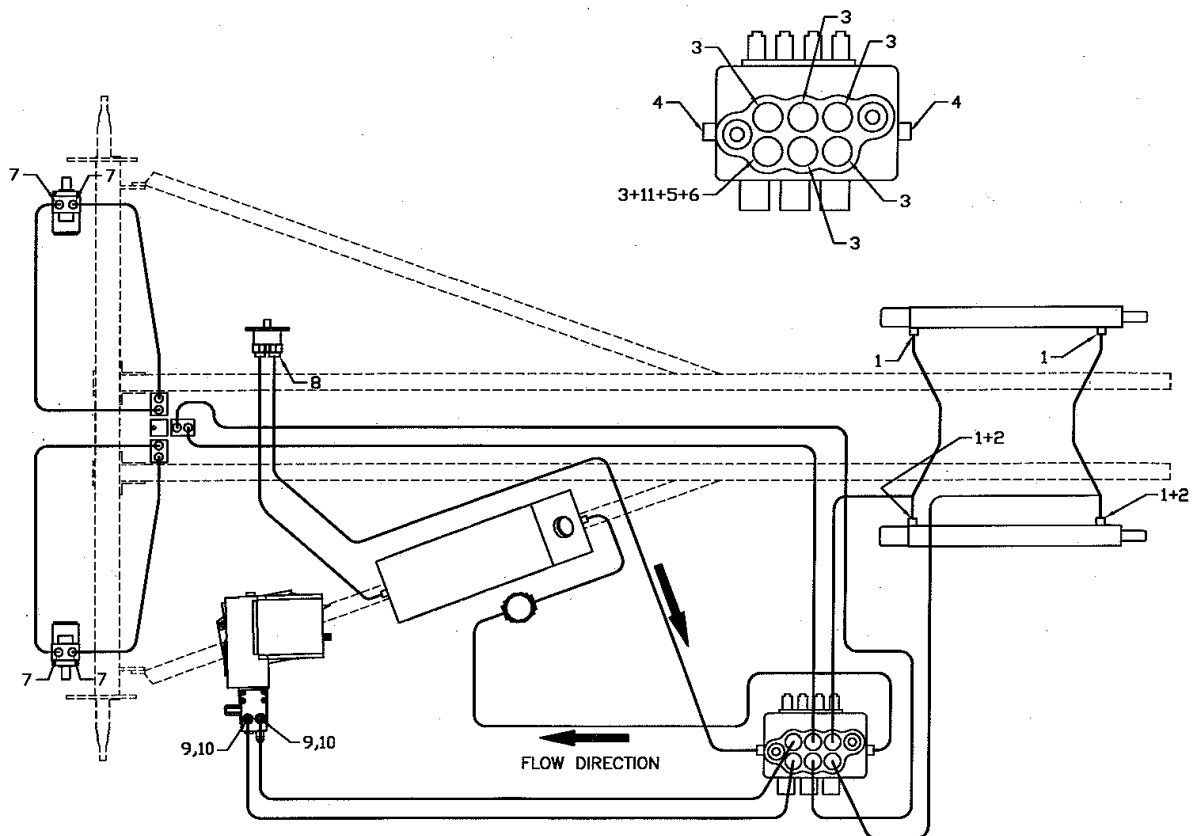

Conventional Auger Mover (Hydraulic Hoses) Small Mover		
ITEM	PART #	DESCRIPTION
1	910250	3/4" x 60" Hose 1.3" MORB x 3/4" SWMNPT
2	910251	3/4" x 24" Hose 3/4" SWMNPT x 1/2" MNPT
3	910260	1/2" x 198" Hose 1/2 MNPT x 3/4 SWFJIC
4	910205	1/2" x 192" Hose 3/4 SWFJIC x 3/4 SWFJIC
5	910206	3/8" x 192" Hose 9/16 SWFJIC x 1/2 SWMNPT
6		3/8" x 192" Hose 9/16 SWFJIC x 1/2 SWMNPT
7	910207	3/8" x 186" Hose 9/16 SWFJIC x 9/16 MORB
8		3/8" x 186" Hose 9/16 SWFJIC x 9/16 MORB
9	910208	3/8" x 60" Hose 9/16 SWFJIC x 9/16 SWFJIC
10	910258	3/8" x 78" Hose 9/16 SWFJIC x 9/16 SWFJIC
11	910209	3/8" x 18" Hose 9/16 SWFJIC x 9/16 SWFJIC
12		3/8" x 18" Hose 9/16 SWFJIC x 9/16 SWFJIC
13	910210	3/8" x 60" Hose 9/16 MORB x 9/16 SWFJIC
14		3/8" x 60" Hose 9/16 MORB x 9/16 SWFJIC
15	910211	3/8" x 48" Hose 9/16 MORB x 9/16 SWFJIC
16		3/8" x 48" Hose 9/16 MORB x 9/16 SWFJIC

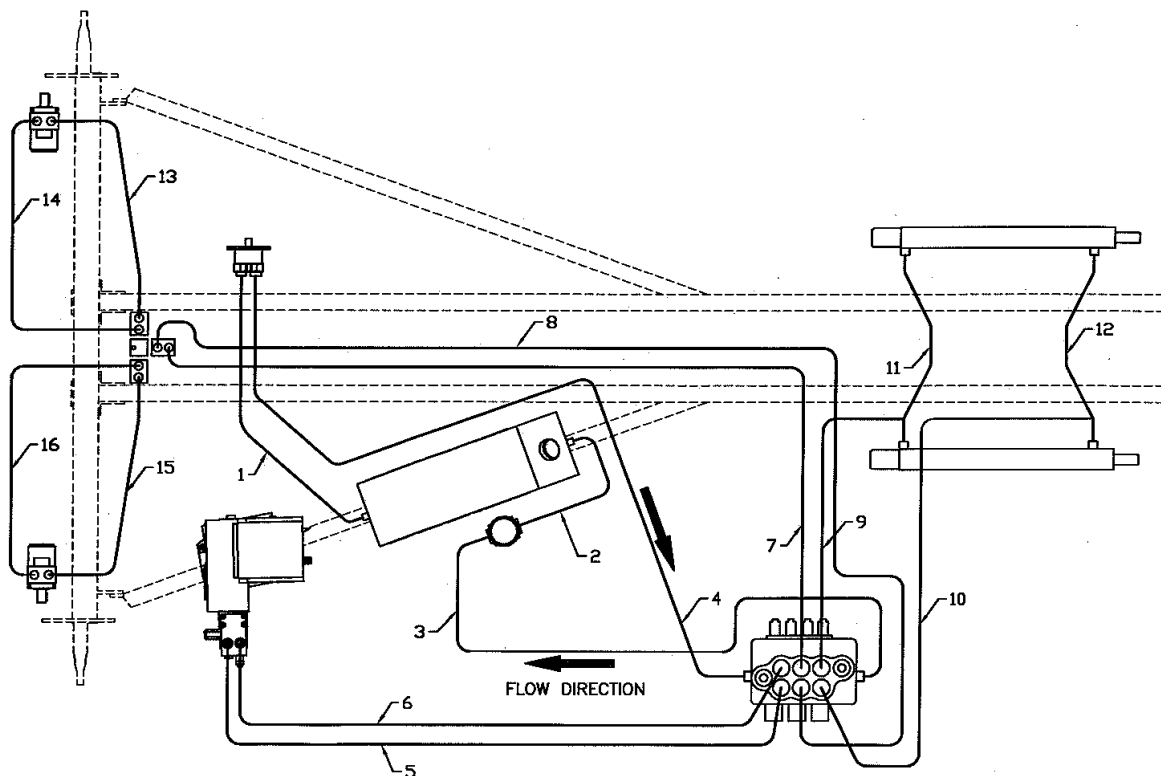

Conventional Auger Mover (Hydraulic Hoses) Big Mover		
ITEM	PART #	DESCRIPTION
1	910252	3/4" x 72" Hose 1.3" MORB x 3/4" SWMNPT
2	910251	3/4" x 24" Hose 3/4" SWMNPT x 1/2" MNPT
3	910253	1/2" x 288" Hose 1/2 MNPT x 3/4 SWFJIC
4	910254	1/2" x 342" Hose 3/4 SWFJIC x 3/4 SWFJIC
5	910255	3/8" x 258" Hose 9/16 SWFJIC x 1/2 SWMNPT
6		3/8" x 258" Hose 9/16 SWFJIC x 1/2 SWMNPT
7	910256	3/8" x 336" Hose 9/16 SWFJIC x 9/16 MORB
8		3/8" x 336" Hose 9/16 SWFJIC x 9/16 MORB
9	910208	3/8" x 60" Hose 9/16 SWFJIC x 9/16 SWFJIC
10	910258	3/8" x 78" Hose 9/16 SWFJIC x 9/16 SWFJIC
11	910209	3/8" x 18" Hose 9/16 SWFJIC x 9/16 SWFJIC
12		3/8" x 18" Hose 9/16 SWFJIC x 9/16 SWFJIC
13	910210	3/8" x 60" Hose 9/16 MORB x 9/16 SWFJIC
14		3/8" x 60" Hose 9/16 MORB x 9/16 SWFJIC
15	910211	3/8" x 48" Hose 9/16 MORB x 9/16 SWFJIC
16		3/8" x 48" Hose 9/16 MORB x 9/16 SWFJIC

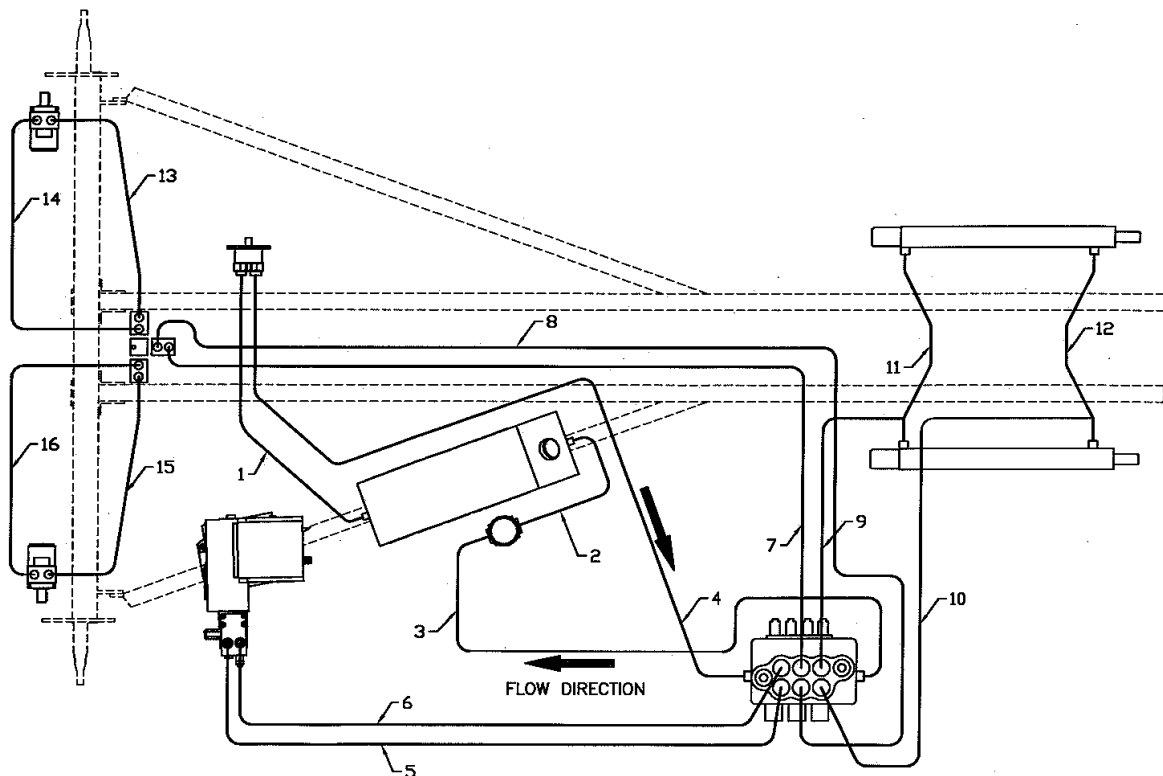

BELT GUARD ASSEMBLY INSTRUCTIONS

1. Mount the 12 inch guard (#2) to the auger. Bolt the belt guard adjustment plate (#7) to the inside edge of the guard using 3/8" x 3/4" bolt, lock washers and hex nuts. This plate should line up with the top and bottom of the guard. The two holes 4 7/8" apart face out with the four holes facing down.
2. Bolt the triangle welded to the top guard weldment (#1) to the adjustment plate. Pick holes that line up best with the belt. Use 3/8" x 1" bolts, lock washers and hex nuts. Bolt the bottom belt guard weldment (#4) to one of the four holes on the adjustment plate using the welded sleeve on the guard with a 3/8" x 4" bolt, lock washer and hex nut. Choose the hole that lines up best with the belt.
3. Join the two guard plates using the 7" adjustment plate (#6). Use 3/8" x 4 1/2" bolts, lock washers and hex nuts fitted through the welded sleeves on the guard plates. The small belt guard (#9) is held on with the same bolts.
4. Bolt the guard support arm to the welded bolt on one of the clamps using a 3/8" flat washer and lock nut. This location must swivel freely. Bolt clamps to the undercarriage arm so the guard support arm fits behind the adjustment plate (#7). Use 3/8" x 1 1/2" bolts, lock washers and hex nuts. Bolt arm to one of the holes at the back of the plate. Which hole is used will vary based upon the motor size. Use 3/8" x 1 1/2" bolt with a 1/4" thick washer between the arm and the plate. Use a 3/8" flat washer and lock nut on the outside.
5. The two belt guard covers (#10) are fitted over the weldments and held in place by two pins and clips on each guard.

CONVENTIONAL AUGER MOVER BELT GUARDS

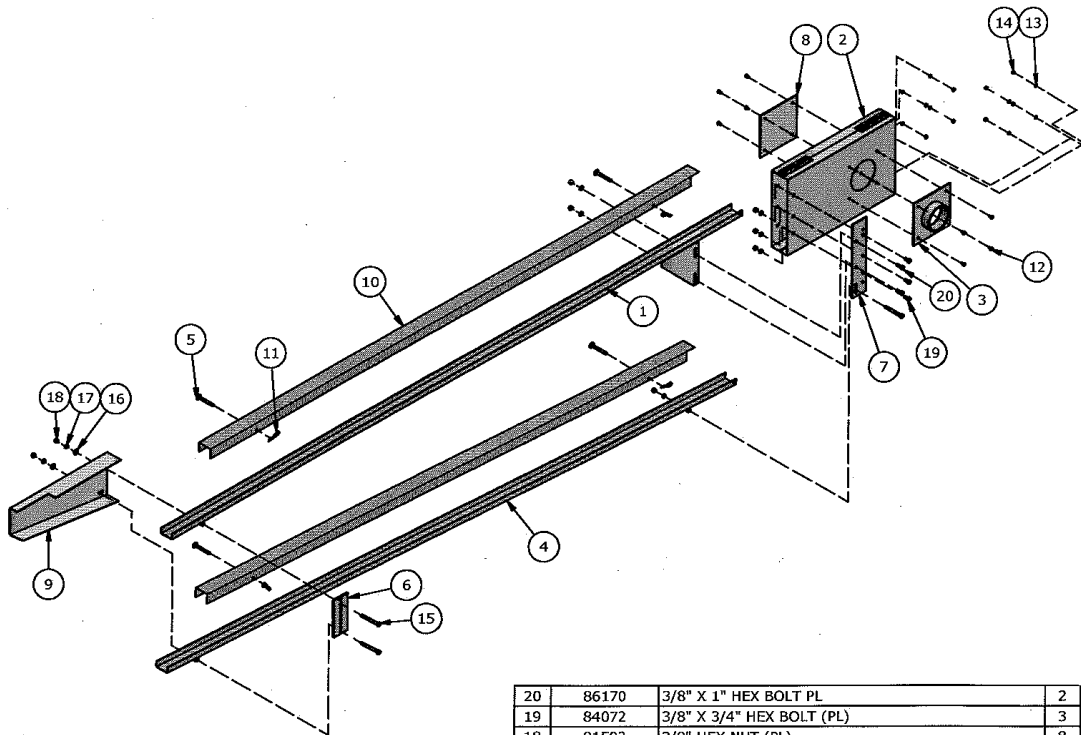

20	86170	3/8" X 1" HEX BOLT PL	2
19	84072	3/8" X 3/4" HEX BOLT (PL)	3
18	81592	3/8" HEX NUT (PL)	8
17	81593	3/8" LOCK WASHER (PL)	8
16	81570	5/16" FL WASH (PL)	2
15	81585	3/8" X 3 1/2" HEX BOLT (PL)	3
14	81544	1/4" HEX NUT (PL)	8
13	81545	1/4" LOCK WASHER (PL)	8
12	81523	1/4" X 1/2" HEX BOLT (PL)	8
11	12780	#7 HAIR PIN CLIP	4
10	910303	BELT GUARD 20GA X 6 X 105.75"	2
9	910308	BELT GUARD PLATE 12GA X 13.5 X 19"	1
8	961358	GUARD MOUNTING PLATE 10GA X 8 X 8"	1
7	910041	BELT BELT GUARD ADJUSTMENT PLATE 7GA X 3 X 14"	1
6	910037	BELT GUARD ADJUSTMENT PLATE 0.25 X 3 X 7"	1
5	910310	BELT GUARD COVER PIN WELDMENT	4
4	910307	BOTTOM BELT GUARD WELDMENT	1
3	961357	GUARD PLATE WELDMENT	1
2	961369	12" GUARD WELDMENT	1
1	910305	TOP BELT GUARD WELDMENT	1
#	PART #	DESCRIPTION	QTY

SHIPPING KITS AND BUNDLE NUMBERS

The following is a list of Kit numbers for this product and the Bundle Numbers, Descriptions, and Quantities for each kit.

C501	Conventional Auger Mover 7" x 46' & Under
C502	Conventional Auger Mover 8" x 46' & Under
C503	Conventional Auger Mover 8" x 51' & Over
C504	Conventional Auger Mover 10" x 46' & Under
C505	Conventional Auger Mover 10" x 51' & Over
C506	Conventional Auger Mover 13" x 46' & Under

NOTES:

DIVISION LOCATIONS

Farm King Division
301 Mountain Street S.
Morden, MB R6M 1X7
Ph.: (204) 822-4467
Fax: (204) 822-6348

Allied/Inland Division
1260 Clarence Avenue
Winnipeg, MB R3T 1T2
Ph.: (204) 284-6100
Fax: (204) 477-2325

B.I.I. Division
1330 43rd Street N.W.
Fargo, ND 58102
Ph: (701) 282-7014
Fax: (701) 282-5865

U.S. WAREHOUSES

AR, West Memphis
(870) 732-3132

GA, Stone Mountain
(770) 908-9439

ID, Meridian
(208) 887-6006

IN, Clarksville
(812) 284-3376

KS, Wichita
(316) 265-9577

MN, Lakeville
(952) 469-5267

MT, Billings
(406) 248-7771

ND, Bismarck
(701) 223-1886

ND, Fargo
(701) 282-7003

NE, Blair
(402) 428-8211

OH, Youngstown
(330) 793-0862

OR, Beaverton
(503) 641-1865

SD, Huron
(605) 352-8616

TX, Houston
(713) 928-2632

UT, Salt Lake City
(801) 972-4321

WI, Portage
(608) 742-1370

CANADIAN WAREHOUSES

B.C., Abbotsford
(604) 864-2665

AB, Edmonton
(780) 962-6991

SK, Regina
(306) 781-2300

ON, Woodstock
(519) 539-0435

QC, Dorion
(450) 455-4840

OFFSHORE WAREHOUSES

Burando Hill
Katanning
W. Australia
011-618-98-214422

Chihuahua, Mexico
011-52-158-90306

John Kerr Equipment Ltd.
Wilcoxholm Farm
Linthgow, W. Lothian
Scotland
011-441-506-842280

Skovde, Sweden
011-46-500-452651

Naestved, Denmark
011-45-557-29511

bühler
Buhler Manufacturing

301 Mountain Street S.
Morden MB.
R6M 1X7
Ph.: (204) 822-4467
Fax: (204) 822-6348
www.buhler.com

Printed in Canada