

AJ-401 LH PLUS

English version / MI_USA - 0117

EDITION N° 06/2011
Code: 507400



WARNING!

Read Operator's Manual before setting up, operating, or maintaining sprayer. Failure to follow safety precautions in this manual and in labels on the product could result in serious injury or death to the operator or bystanders.

Keep manual nearby for further reference. If manual is damaged or illegible, contact your Jacto dealer or Jacto at the address below for a replacement.

Operator's Manual



JACTO INC.
19217 SW 119th Ave
Tualatin, Oregon 97062
Tel.: (503) 885-8723
Fax.: (800) 511-3671
Toll Free: (800) 522-8610
E-mail: info@jacto.com
Home page: www.jacto.com

Introduction

Precautions.....Chapter 1



Assembling.....Chapter 2



Technical specifications.....Chapter 3



Operation and Adjustments.....Chapter 4



MaintenanceChapter 5



Warranty.....Chapter 6



The agrochemicals application is necessary to achieve higher and economical production.

However, since applying agrochemicals can present risks to humans, the environment and to crops, Jacto is concerned about helping users to use these sprayers in a proper, efficient, and safe way.

Therefore, read carefully and understand thoroughly this manual before operating this sprayer and keep it always at hand when handling this sprayer for quick consultation in case you are not quite sure of some operation or adjustment.

If you still have questions, contact your Jacto dealer.



ATTENTION!

The AJ-401 LH PLUS was developed exclusively for the chemical spray application. The AJ-401 LH PLUS sprayer manual refers only to instructions of use and maintenance of parts and components manufactured by Jacto. Read it carefully and follow strictly the instructions. Should your doubt persist, please contact your Jacto dealer.

> Identification plate

Your sprayer has a plate showing its model and serial number.

This information is very important so that Jacto can keep records of eventual modifications made on the material used and on its construction characteristics.

In requesting replacement parts or maintenance, always specify the model and serial number of your sprayer for prompt and efficient service.



JACTO is trademark registered by MÁQUINAS AGRÍCOLAS JACTO S.A.

JACTO RESERVES THE RIGHT TO CHANGE SPECIFICATIONS AND DESIGN WITHOUT PRIOR NOTICE.



Safety manual 9

Safety decals 10

Safety guidelines 13

Safety recommendations for transport 14

Recommendation to unload the equipment 15

Operational safety 16

Warning to assemble the components 17

Warning when using and filling the tank 18

Safety agrochemicals application 19

Maintenance safety 22



This chapter of the manual guides the operator to work safely with this equipment.

It is important to remember that this equipment was carefully developed so as to provide maximum efficiency with economy, easy operation and safety.

In order to accomplish this, be always aware to the information provided on the owner's manual. If any question comes up at anytime, please contact us.

The instructions on this manual are accompany with symbols which have the following interpretation:



ATTENTION: to inform potential risk's situations of accident, which demands constant attention from the operator.



NOTE: reminds or warnings.



OBSERVATION: warn or clarify certain instructions/situations.

To ignore the safety procedures, you are risking your life and all the people around you.

> Operator and owner's responsibilities

According to the standard NR31 - Safety and Healthy Regulation Standard in the Agriculture Work, the owner and the agriculture equipment's operator can cooperate with the chemical application safety, since they be aware of their responsibilities.

Operator's responsibilities

- To follow the determinations about safety procedures to accomplish with his activities.
- To operate the equipment within the limits and restrictions indicated in this manual.
- To read this manual and ensure to understand all the information prior to use the equipment.

Owner's responsibilities

- The equipment's owner must keep the owner's manual in a place of easy access to the operator when needed.
- It's the employer duty, always when in use of chemical, to provide the adequated EPI - Individual Protection Equipment, to take care of the EPI hygienization, to trainee the operator to require and make the EPI use.
- The employee must to replace or repair the equipment's components always when they present any defect that put in risk the a safety operation.
- The employee will be responsible for the operator's training to ensure a safe application.



Safety decals are placed on the equipment to reduce the risk of damages or accidents to the operator or to the equipment during the use.

Before operating the equipment, identify and understand the mean of all decals, through this page.

Keep them in good repair, clean and legible. Replace them immediately in case of damage by ordering them through the part numbers specified below.



ATTENTION: Lubrication point

P/N: 276220



ATTENTION: Read the operator's manual before operating the sprayer.

P/N: 379248



ATTENTION: Read the operator's manual before operating the sprayer.

P/N: 379230



ATTENTION: Obligatory use of protective mask.

P/N: 379115



ATTENTION: Risk of injuries. Keep away from the sprayer when it is running.

P/N: 379040



ATTENTION: Obligatory use of hearing protector.

P/N: 379123



ATTENTION: Risk of serious injuries. Keep away and do not make any kind of maintenance while the fan is in motion and the PTO is engaged.

P/N: 379057



P/N: 379065

ATTENTION: Risk of serious injuries. Keep all protection devices in its places.



P/N: 379008

ATTENTION: Risk of serious injuries. Do not make any operation on the PTO shaft if the PTO is engaged.



P/N: 379073

ATTENTION: Clean water tank for washing hands.



P/N: 379131

ATTENTION: Obligatory use of protective clothing.

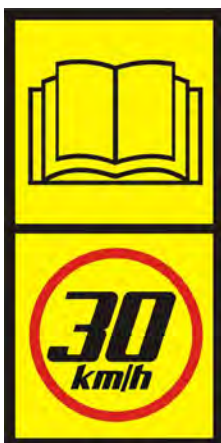

P/N: 379214

ATTENTION: Maximum speed allowed for the machine is 18.5 mph.



P/N: 379222

ATTENTION: This machine is not allowed in high-ways.



P/N: 169128

ATTENTION: Never operate the valve of the chemical rinse nozzle if the container is not duly positioned over the rinse nozzle.



P/N: 013169

Final test of the equipment.



ATTENTION: Do not get into the main tank of the sprayer.

P/N: 380014

		ATENÇÃO	ATTENTION	ATENCIÓN
	IMPLEMENTO TRAFECTOR	GARRETAS B = 30 cm 3 PONTOS B = 5 cm	MONTAR OS GARFOS CONFORME INDICADO EM 'A'. CASO SEJA NECESSARIO, CORTAR AS BARRAS DO CARDAN DEIXANDO FOLGAS CONFORME INDICADO EM 'B'.	MONTAR LAS HORQUILLAS SEGUN INDICADO EN 'A'. CASO SEA NECESARIO, CORTAR LAS BARRAS DEL CARDAN DEJANDO AFLGOS CONFORME EN 'B'.
		TRAILER B = 30 cm 3 POINT B = 5 cm	MOUNT THE FORKS AS INDICATED IN 'A'. IF NECESSARY, CUT THE PTO SHAFT AND SHIELD CAP, LEAVING CLEARANCES AS SHOWN IN THE FIGURE.	

Instructions to connect the PTO shaft

P/N: 428631



Identification plate

P/N: 047035



- Only qualified operators and with information's knowledge of the owner's manual that comes with the machine must operate the AJ-401 LH PLUS;

- Prior to initiate any operation, it's very important to be aware all the information in this manual. In case of doubts, please contact Jacto.

- Do not drink alcoholic drinks, sedative or stimulant before or during work.

- During the chemical handling, always use EPIs approved, recommended and adequated like: long sleeve coverall, water resistant, gloves, hat, boots, special mask with filter for each type of chemical. In case of doubt, please check the chemical label or get in contact with the chemical manufacture.

- When checking the machine's components that are in direct contact with the chemical, use EPIs approved and in accordance with the recommendation in the chemical label.



- If you're using cabin tractor and it has air filter system, clean up the shoes and take off the contaminated clothes. Keep them out of the cabin in a sealed place.

- If the tractor's manufacture recommends, use ear protector.

- Use breath facial protector (mask) approved, recommended and adequated if the chemical label requires the individual protection.

- Be aware. Keep away from places where there're obstacles like trees, rocks, bumps, electric post, etc.



- The use in different conditions and not recommended can compromise the equipment's integrity and components, failuring to warranty and exonerating the manufactory of any accident and consequences.

- Avoid to park the tractor in inclined places. If necessary, use block behind the tires when parked in inclined areas.



- Keep a step and handrail always clean; oil and grease can cause accidents.
- Do not use equipment if there is repair need in some key components. Make the repair previously.
- This equipment can cause accidents if used inept or irresponsibly.
- Do not hop on the machine when it's moving.

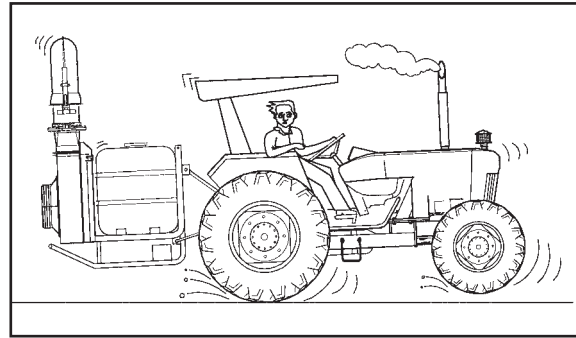

> Safety recommendations for transport

- Before initiate the transport, it's important that the track where the equipment will be transported be carefully studied and that the regulator body that regulates this type of transport be contacted about the law and legislation current.
- All freeways, roads and streets that have utilization characteristics for utilization that are influenced by natural's factors (clime, growing of a tree without mankind interference, etc.) and construction (used material, bridges height, electric post, lane width, etc). These characteristics must be carefully valued before the equipment transportation.
- In case doubt, do not make the transport. Contract a specific company for this type of job.
- Be sure that the chemical circuit was rinse and the tank is totally empty after rinse. The checmical leaking, as minimum it can be, may risk put in risk people's life, animals, envirolment.
- Wash outside the equipment after it's use. Even it looks clean, tje strps used to hold the equipment must not be reused to hold food, the straps may be polluted and pollute it.
- During the equipment strap process, make use EPIs. If necessary, make a combination of the required EPIs during the equipment load (i.e.: safety boots, gloves, helmets, etc.) with EPIs required for the chemical application. This combination will minimize the contamination risk.
- The equipment hold on the truck or trailer must be done by the tires and by the specific points (see illustration below). The hold must be made safety, since it can cause serious accident's risk.

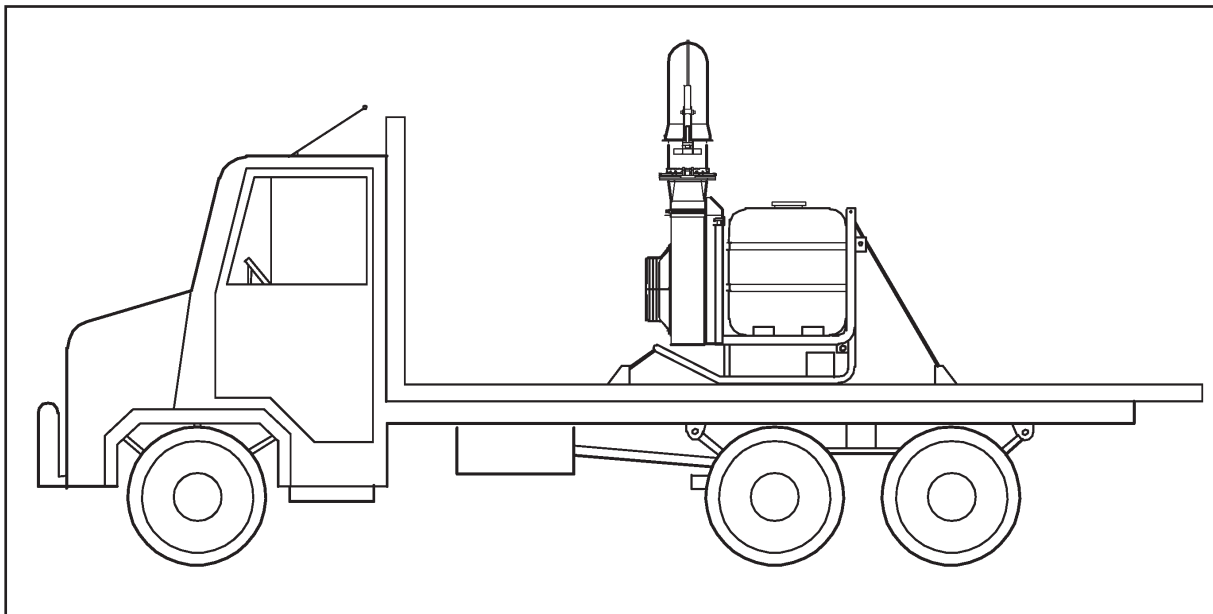



- Desengage the equipment from the tractor, hook the jack. Do not forget to install the safety chain in the traction bar.
- The unload must be in specific's places for this type of job. Do not make improvisation to unload the equipment.
- During the strap's remove that holds the equipment, make sure to use EPI. If the equipment is used use EPI to unload the equipment (i.e.: safety boots, gloves, helmet, etc.) with the EPIs used for spraying (i.e.: mask, gloves, etc.), to minimize the contamination risk and accident.
- To unload the equipment, use a tractor with capacity for this type of job. The tractor to be used must be according to its pull capacity and sprayer weight.
- Do not disassemble removable parts from the equipment such: PTO shaft, etc; before unloading the equipment from the truck or trailer and park in a safety area.
- After positioning the equipment in a safety area and far from electric post, hook up the jack and unhook the equipment from the tractor.

> Warning To Hook up the Equipment to the Tractor's Traction Bar

- Check the owner's manual prior to do this operation. The warning related to follow are recommended just for the J400 hook up too the tractors. Warning related to the use and component's adjustment of the tractor are its manufacture's responsibilities.
- The information related to the correct adjustment of the traction bar and the procedures to hook up the equipment the right way are exposed in chapter "ASSEMBLY" in this manual.
- The hook up operation of the equipment to the traction bar can be made for more than one person. In this case, the people involved must be aware of risks, trained, qualified and experienced this type of job.
- Avoid to stand on the tractor's way. If possible, hook up the equipment by yourself. Do not forget the safety chain in the traction bar.
- Before to get out of the tractor to do the hook up, activate the parking brake. Turn off the engine and remove the key from the ignition.
- After hooking it up, put on the jack on the working position and move the equipment to the place where the assembly will be made.

**ATTENTION!**

Ignoring the safety practices, you're risking your life and all of those around.

This manual contains important safety advices. Read it carefully, and be aware to any possibility of personal accident. Keep all the stickers on the machine and replace it, if necessary.

- The incorrect handling by unprepared personal can cause serious accident or fatal.
- Do not make adaptations or improvisations; they can compromise the equipment and risk your life.
- Do not allow children, elderly or animals close to the equipment during it uses, maintenance or even with the equipment stored.
- Keep hands, feet, loosen clothes and long hair far from moving parts.
- Before executing any type of service, adjustment or maintenance in your equipment, turn off the PTO shaft and the tractor's engine.
- If the equipment used, even if it was washed and seems to be clean, use all recommended EPIs for chemical handling.
- Do not touch PTO shaft, belts, fan or any other moving part of the equipment with the PTO shaft or tractor on.
- When unhook the machine, keep it in firm terrain, flat, and if the equipment has parking brake, activate it!
- Do not run the pump dry.
- Do not exceed 540 rpm at the PTO.
- Keep the machine always in perfect care.
- In all over the equipment were placed safety's stickers guiding about the risk of damage or accident that can happen to the operator or to the equipment.
- Request a JACTO representative during the technical delivery of the equipment for a proper assembly instructions, maintenance, warranty instructions to be carefully explained.
- **It is totally phrohibit the use of PTO shaft without the shield.**





> Warning to adjust and hook the PTO shaft into the tractor

- Check the tractor's owner's manual prior to do this operation.
- Turn off the tractor's engine, activate the parking brake and remove the key from the ignition, before to hook the tractor's PTO.
- Try to engage the PTO shaft into the tractor's PTO. In case it's necessary to adjust the PTO shaft's length, make use of specific EPIs for this operation: safety glass, gloves, boots, etc.
- When hooking the PTO shaft in the tractor, make sure to lock the safety pin.
- The instructions on how to adjust the PTO shaft's length correctly are in chapter 2 "ASSEMBLY" in this manual.
- After adjusting the length, clean and lubricate the PTO shaft's components. In this case, use protective gloves.
- **Never use the PTO shaft with no shield.**
- The PTO shaft will be adjusted for the specific use of the J400. It's not recommended to use the PTO shaft for other equipment.
- Do not make adaptations and PTO shaft reuse.
- Fix the safety chain from the PTO shaft shield in the tractor; this chain will avoid that the shield spin with it.
- Before to turn on the tractor's PTO, fill up the tank.

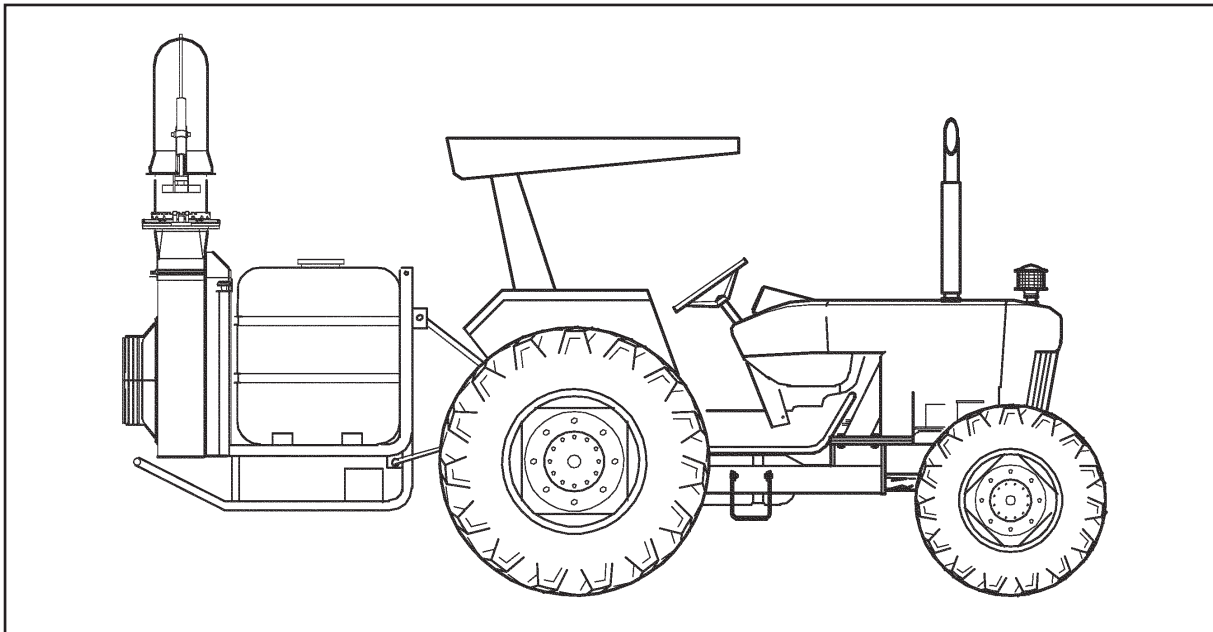



> Fresh water tank for hand's wash

- Fill up the fresh water tank for hand's wash only with clean water. The use of soap or solutions are prohibited.
- In any circumstance the water in this tank must be drank or used for other use.
- It's extremely important to keep that this tank always full.

> 105 Gallon tank

There're two ways to fill up the 105 gallon tank. The instructions for this operation are explained in chapter 4 "OPERATIONS AND ADJUSTMENTS" in this manual. The warning in to fill this tank are the following:

- For the filling of the 105 gallon tank, it's important that all personal involved use the indicated EPIs. It's important to read the chemical's label used. On the label you'll find many information about the product, warning, etc.
- Prior to initiate the fillinf, make sure that the drain cap is tight.
- Never remove the filling hose from the quick fitting, with the filling valve open. In case the valve is open, overflow can happen through the filling hose.
- The residuos exisiting in the hose must be removed with a bucket and returned to the tank. Do not leave residuos on the floor.
- Do not pollute water fountain. The sprayer filling with the filling unit must be used in an appropriated are for this.
- Avoid to get water from rivers, lakes, etc.
- Following these recommendations you'll save the enviroment.



1 · READ the operator's manual of the sprayer: To spray efficiently it is necessary to know the sprayer fully. This way, the chemical waste and the bad use of the equipment will be avoided, and the desired result will be obtained.

2 · Correct ADJUSTMENT of the sprayer: The adjustment of the sprayer is a simple operation. Only with the sprayer adjusted the best results will be reached.

3 · USE appropriate individual protective clothing: When handling chemicals or preparing the chemical mixture, use the protective individual clothing recommended by the agrochemical manufacturer. After spraying, take a shower and change the clothes. Wash the working clothes immediately and separately from other clothes to remove the chemical residues.

Wash at least 15 minutes with running water any part of the body that have touched agrochemicals. Remember that most of poisoning cases occur during the preparation of the chemical mixture when the chemical is still concentrated.

Do not wear or store into the cabin the protective individual clothing used to hand or prepare the chemical mixture in order to not contaminate the local.

Inside the cabin, use only hearing protector when operating the machine and/or spraying. When perceiving a contamination (smell of chemical) caused incautiously by open door or windows or entry of contaminated materials in the cabin, immediately use a proper and approved protective mask and contact your dealer.

Special protective masks with filters are only indicated if the chemical in use requires them.

4 · USE the sprayer in perfect conditions: Check if there is no leakage. If any, eliminate it. Leakage not causes only agrochemical waste but also irregular spraying and environment contamination.

5 · USE the appropriate nozzle: Each agrochemical has an appropriate nozzle for its application. The weather also has influence when choosing the nozzle. The spraying volume can vary from one chemical to another. Contact your chemical manufacturer to choose the ideal nozzle.



AJ-401 LH PLUS

Safety in agrochemicals application

6 · NEVER blow through nozzles, valves or pipelines by mouth. For this operation use protective gloves. All spraying equipment has agrochemicals residues. Never put spraying parts in touch with mouth. This is the quickest way to be poisoned. If it is necessary to clean the nozzles, use a nylon bristle brush (toothbrush).

7 · NEVER contaminate water sources. The sprayer must be filled in proper places or through vehicles (trucks, etc.) designed for this operation. Avoid using water from rivers, lakes, dams, streams, etc. PROTECT THE ENVIRONMENT.

8 · NEVER eat, drink or smoke when handling the chemical or spraying neither keep food next to the sprayed area.

9 · KEEP children, animals and unprotected people away from the sprayed area. Never allow that children or other unsolicited people remain in the areas of chemical handling or application.

10 · APPLY only the recommended rate: The application rates recommended by the manufacturers must be followed. They are result of many years of research. Any change in the application rate or error in calculating it can damage the crop or the environment. Never use chemicals on crops for which they are not recommended.

11 · NEVER spray when the wind is strong: The excessive wind can cause several problems. It prevents the agrochemical from reaching the target, thus causing bad distribution on the crop, besides blowing the sprayed chemical against water sources, animals and environment. Never spray if the wind speed is over 10 km/h. A good application can be obtained when the wind speed is between 3 and 7 km/h, the temperature is between 7 and 30 C and the relative humidity is over 55%.

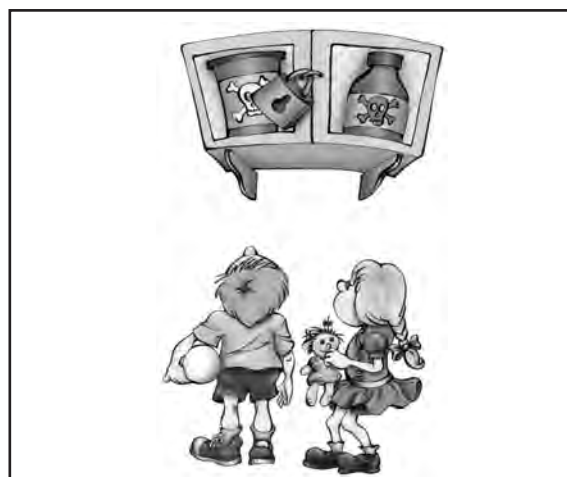
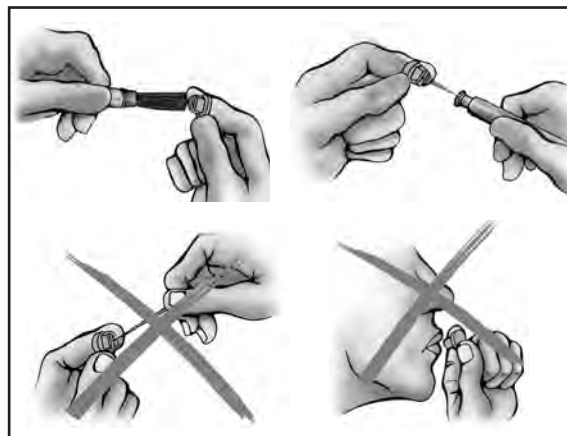



12 · RINSE the chemical containers before discarding them: After preparing the chemical mixture, rinse for around 30 seconds.

13 · NEVER reuse empty chemical containers: Even after rinsing the chemical containers many times, they still have residues. Never burn empty chemical containers. Make them useless by piercing their bottom and store them in a safe place until they are picked up for recycling.

14 · NEVER fill the sprayer up to the lid level: This way, you can avoid chemical leakage and the possible poisoning of the operator and contamination of the environment. Fill the tank up to the maximum level indicated by its level indicator.

15 · WHEN TRANSPORTING agrochemicals: Never transport them with food or animal's food, etc. Never buy leaking chemical containers. Never buy or use agrochemicals with expired validity. Never carry agrochemicals inside the cabin. In case of accident that causes leakage, take measures to prevent the agrochemical from reaching lakes or rivers. Inform the authorities and the agrochemical manufacturer.

16 · WHEN STORING: Build a masonry store for agrochemicals. Cover the ground with impermeable material. Use a platform to store agrochemical containers on. Keep in the store a drum with sand to absorb eventual leakages. Outside the store, install a tap and a shower for the sprayer operators.

17 · SYMPTOM of poisoning: Faints. Anxiety. Convulsions. Weakness, headache, indisposition, dizziness, different vision. Sickness, stomachache, diarrhea. Urine with different color and consistence. Eyes, nose and throat irritation. Cough and tears.

18 · FIRST aid: If the person vomits, keep him/her seated. Never give alcoholic drink or milk to poisoned people. Keep the person calm and comfortably positioned. Find the agrochemical label. Call a doctor.





The knowledge and the follow of recommendations in this manual minimize the cost of maintenance and increase the equipment lifetime.

- The maintenance job must be done by capable and qualified professionals. Even if the equipment has been rinsed, it's necessary the use of the following EPIs: long sleeve coverall, waterproof jacket, gloves, safety glasses, boots and specific mask with the appropriated filter.
- Use original parts, they guarantee a perfect operating of the equipment.
- Maintenance repair must be done with the equipment connected to the tractor, with the tires blocked and the tractor's engine and the PTO off.
- Do not improvise or use inappropriated when doing the equipment's maintenance.
- Filters and lubricate oils must be checked periodically and changed always when necessary or recommended.
- All maintenance labor in tubing or hydraulic's hoses must be done after removing the pressure from the circuit. Be caution during this type of maintenance.
- The identification of possible leakage must be done with paper, and never by hand.
- Being the equipment connected to the tractor and to the PTO, be carefull and stay away from the equipment's moving parts; they must be with it's protections. In case of doubt, call for technical assistance.

- If there's no possibility to do the maintenance with the tractor's engine off and out of the building, keep doors and windows wide open to circulate the air. The running of engines in closed areas produce toxic gas and can asfixiate the operator in minutes.
- It's prohibited to clean, lubricate and do maintenance with the machine running, except if it's required and in this case specials measures for protection and signage must be taken to avoid accident.
- The welding labor to booms, chassis or any metal part of the equipment, must be done only after removing the battery's cables from the tractor and tank drain and rinse.
- Always keep the stickers on the machine in perfect conditions. They provide important warning and recommendations.
- The removable protectors must be removed only for maintenance, lubrication or adjust purposes. They must be put back in place.
- The lubrication labor must be done by a qualified person. This procedure involves many risks like: slipery, contamination, etc. For this process, it's recommended to use gloves, safety glasses, boots. If the equipment is used, use facial breath protector (mask) appropriated.
- Do not get into the 105 gallons tank. If necessary call technical assistance.





Choosing the tractor03

Setting up the tractor04

Mounting the sprayer to the tractor.....05



Different working conditions lead us to adopt the following criterion for choosing the tractor that will drive the Jatão 2600 cannon sprayer.

- Check the sprayer weight on the identification plate.
- Check the tank capacity.
- Check in the technical specifications table the total power consumption required.

Example:

Sprayer weight = 507.15 lb
Tank capacity = 105 gallons
Total power consumption = 14.5 HP

> Choosing the tractor considering the power consumption

The tractor should have power (HP) at least 90% higher than the power required to run the sprayer.

Ex.: Power required by the sprayer = 14.5 HP

Tractor recommended: with minimum nominal power of 27.5 HP

> Choosing the tractor considering the lift capacity of the hydraulic system

The lift capacity of the tractor's hydraulic system must be higher than empty sprayer weight added to the weight equivalent to the tank capacity.

Ex: Empty sprayer weight = 507.15 lb

Tank capacity = 105 gal (approximately 882 lb)

Tractor recommended: with lift capacity of hydraulic system higher than 1,389.15 lb.



ATTENTION!

The figures above are specifically mentioned in order to direct you on how to proceed to choose the ideal tractor to which you are to mount your sprayer.



> Adjusting parts to hitch to the tractor's three-point suspension



ATTENTION!

The instruction below is an example of what should be done for properly hitching the sprayer to the tractor's three-point suspension. To exemplify we have used the Ford 4600 tractor. However, you should proceed as directed in the operator's manual of your tractor.

> Tie arm of the left bar

- To adjust the length of the left lift arm to the proper position, loosen the pin and turn the lower half (2) of the lift arm.



NOTE:

The grease fitting (1) should point up.

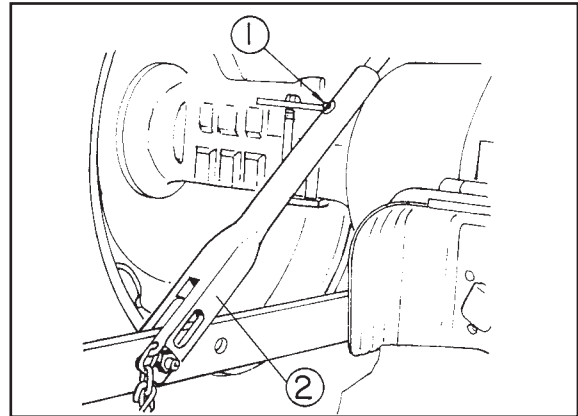

> Levelling box

- To adjust the transversal levelling of the sprayer, turn the crank (1) located on the levelling box.

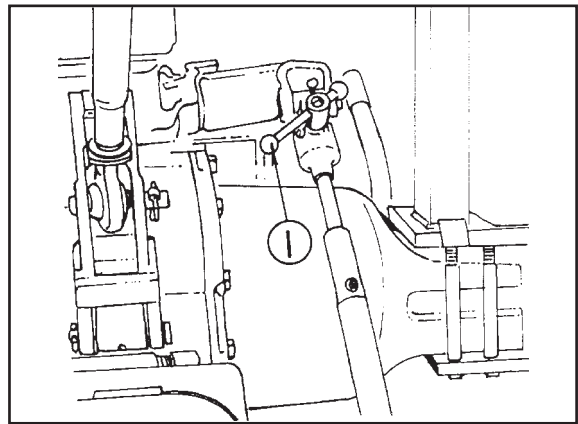

> Adjusting the third point

- Release the lock (1) and turn the sleeve (2) to adjust the length of the third point arm. During transport, fasten the plate of the third point bar to the pin (3) of the frame.

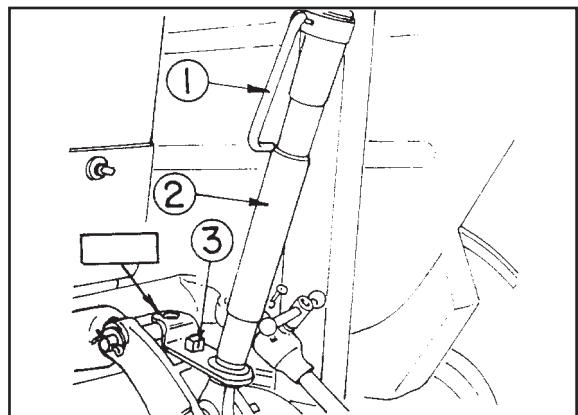



> Third point frame

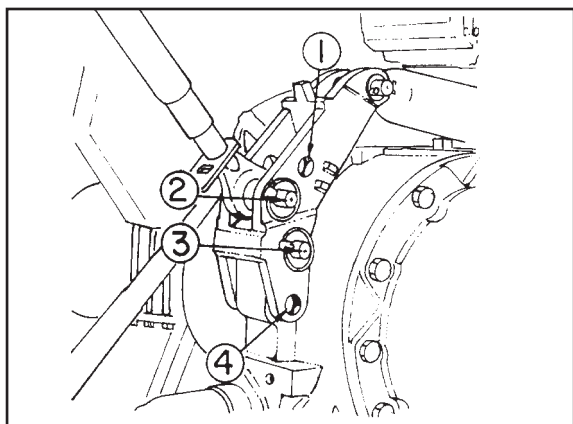

- The third point frame has two positions (1 and 2) to install the third arm and two positions (3 and 4) to install the frame lower pin.
- Thus there are four different positions for this assembly.

> Holes position

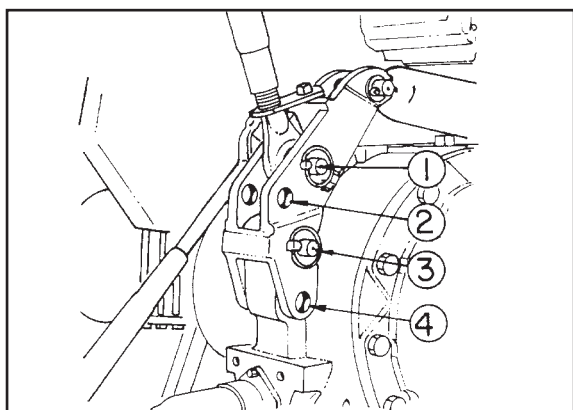

- The positions of the holes vary according to the duty to be done.

Third arm's position	Frame	Duty kind
Nº 1	Nº 4	Ultra-light
Nº 1	Nº 3	Light
Nº 2	Nº 4	Medium
Nº 2	Nº 3	Heavy

> Stabilizing chains

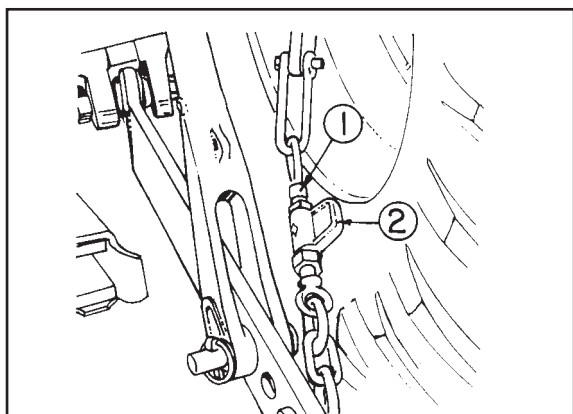

- The stabilizing chains should be installed to limit the lateral movement of the sprayer hitched to the three-point system.
- These chains should be adjusted according to the boom of the sprayer to be used. To adjust them, relieve the lock nut (1) and turn the adjusting nut (2), as necessary, and retighten the lock nut.



- Remove or pull the tractor's drawbar aside.

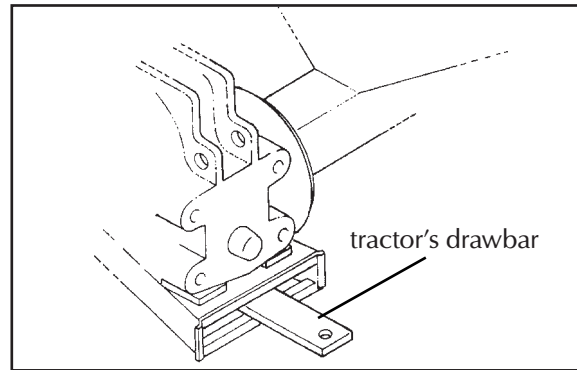

- Mount the sprayer to the tractor's three-point suspension and level it as shown in the figure beside.

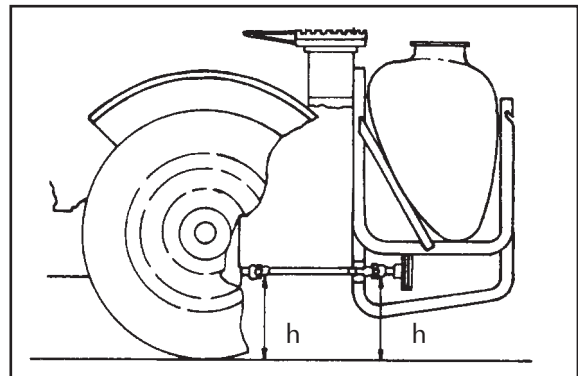

- Adjust the tractor's hydraulic lift lever so that the sprayer is not raised too high.

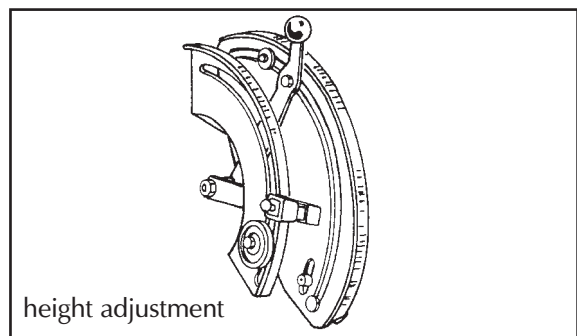

- Adjust the PTO shaft. If necessary, cut the male and female tubes so that, after connecting the sprayer, it has the overlaps recommended in the figure beside.

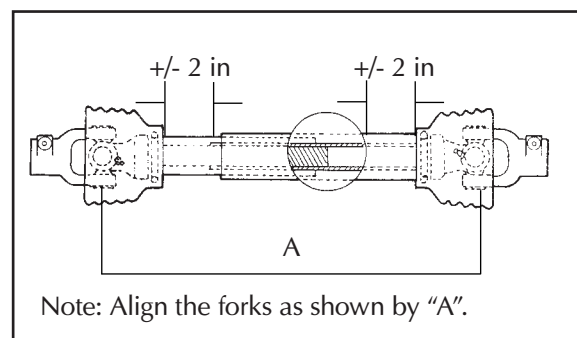
**ATTENTION!**

Before cutting the tubes, check for all possibilities of movement of the sprayer on the lift arms and third point.

Make sure the hitch pins locks are correctly installed.

For instructions in detail, refer to the section MAINTENANCE - PTO SHAFT.



Presentation - AJ-401 LH PLUS..... 03

Technical specifications 04

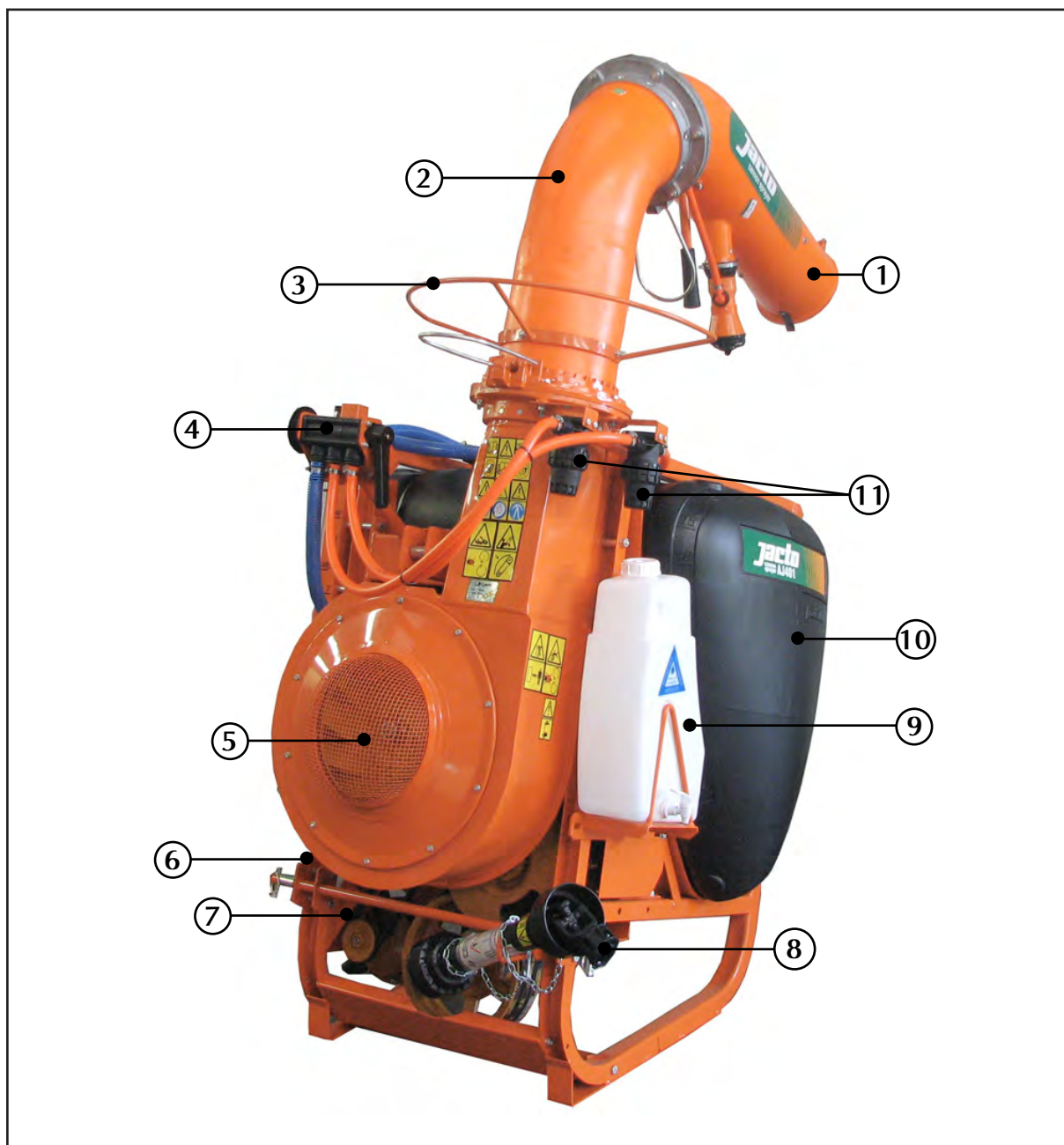

1 - Main spout

2 - Auxiliary spouts

3 - Spout adjustment handle

4 - Control valve

5 - Fan

6 - Filling unit

7 - Pump

8 - PTO Shaft

9 - Clean water tank

10 - Tank

11 - In-line filter



AJ-401 LH PLUS

Technical specifications

Model AJ-401 LH PLUS

Weight

Net weight 507 lb

Dimensions

Length..... 57 in

Width..... 45 in

Height..... 79 in

Tank

Material..... Polyethylene

Capacity..... 105 gallons

Clean water tank

Material..... Polyethylene

Capacity..... 3 gallons

Level indicator Level indicator with graduated scale

Pump

Model Centrifugal (single rotor)

Capacity..... 31 gpm

Rotation 3,628 rpm

Filter

Model in-line filter II

Mesh..... 80

Spray swath

Without wind..... 49 ft

With wind at 3 mph..... 82 ft

Fan

Rotation 3,630 rpm

Air speed..... 143 mph

Air volume 3,772 cfm

Power consumption 12.8 HP

Recommended maximum working speed 1.5 to 4 mph

Total power consumption 14.5 HP



Pump	03
Flow rate regulating valve	03
In-line filter.....	03
Spout	04
Nozzles.....	04
PTO Shaft.....	05
Clean water tank for washing hands	05
Spout cap.....	05
Fan housing cover	06
Filling unit	06
Spray application technology	07
Selecting the spray swath	09
Calibrating the sprayer (formula)	10
Determining the spout flow rate	11
Ultra low volume application	12
Ultra low and low volume application	12
Low, medium and high volume applications	14
Tractor path and spout inclination	16
Calibrating the sprayer (practical method)	17
Diluting the chemicals.....	18
Chemical container rinse.....	20
Triple wash of chemical containers.....	22



> Pump

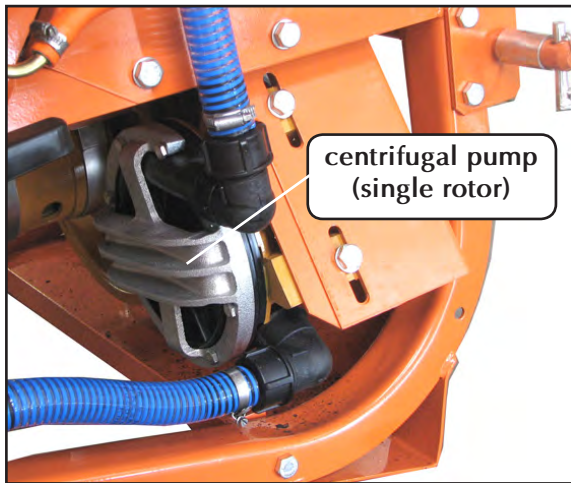

- The pumps mounted to Jacto cannon sprayers have flow rate ranging from 29.06 up to 39.63 gpm.

- These pumps can be single-stage (one rotor) or dual-stage (two rotors), as shown in the section PRESENTATION OF SPRAYER - TECHNICAL SPECIFICATIONS.

- The combination of a high flow rate pump with low power consumption allows the use of a powerful fan, making this cannon sprayer one of the most efficient unit as regards operational performance.

> Flow rate regulating valve

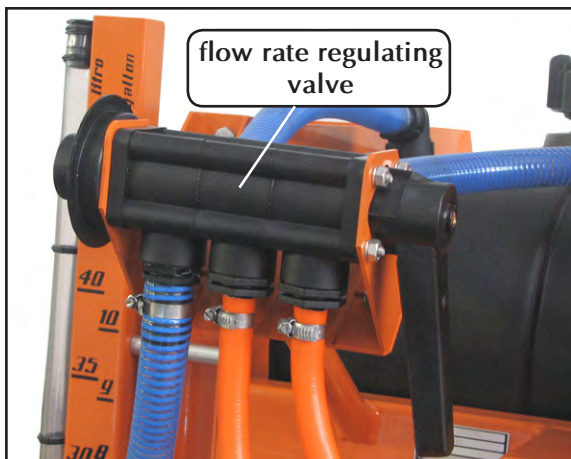

- This valve allow to calibrate your cannon sprayer by setting the lever within a scale from 0 to 4, giving flow rates ranging from 2.6 to 8.7 gpm.

> In-line filter

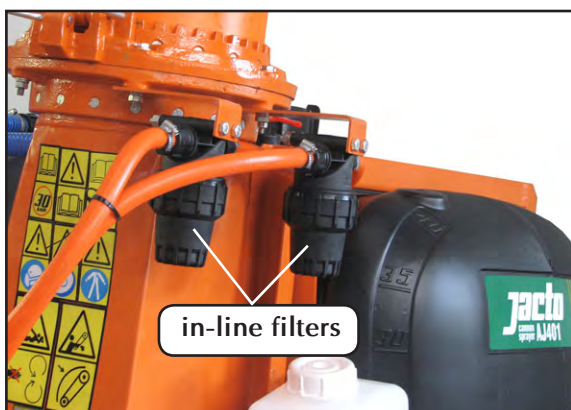

- This sprayer is equipped with two in-line filters: one for the main spout and one for the auxiliary rotary atomizer. These filters have 80 mesh and optimize the filtering of the chemical mixture flow to the nozzles.

Characteristics:

- Maximum working pressure150 psi
- Filtering element mesh80
- Hose fittingø 1/2"



> Assembling

- Make sure the pressure hose is connected in the direction indicated by the arrow embossed on the filter body.



ATTENTION!

- Clean the filter whenever filling the tank, or when necessary.
- Do not exceed the recommended pressure (150 psi).

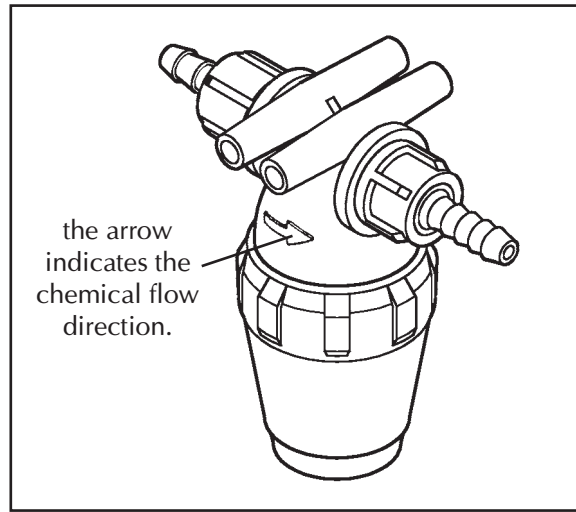

> Spout

- The main spout can be easily adjusted both vertically and horizontally. As the adjustment handle is located in a convenient position to the tractor's driver, it can be adjusted even during the application. In addition, it has an auxiliary rotary atomizer to cover the area close to the tractor, thus improving the quality of applications.

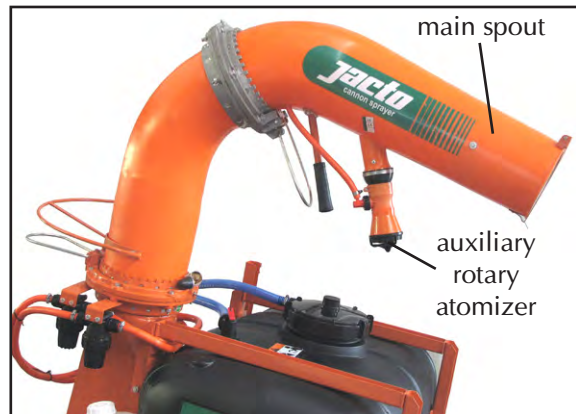

> Nozzles

- The job of the nozzles is to generate droplets and distribute them uniformly over the area being sprayed.
- Flow, size and distribution vary according to the air volume generated by the fan. Therefore, always work as directed in the operator's manual.





> PTO Shaft

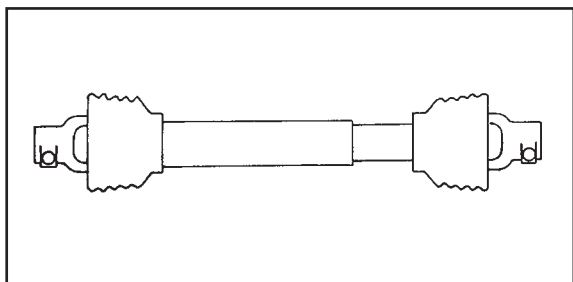

- The PTO shaft has plastic protection guards to prevent the rotating male and female tubes from touching the operator or his clothes, thus reducing the accidents, as well as from damaging the crop.

- Also, at the end that is connected to the sprayer there is a unlocking system to relieve overcharges in the transmission.

> Clean water tank for washing hands



- This is a 3 gallons plastic tank located in a place of easy access which must always be filled up with clean water for washing hands and other parts of body that have touched chemicals during the use of these products.



ATTENTION!

Non-drinkable water.
Only use the water from this tank to wash hands and other parts of the body that have touched chemicals.

> Spout cap



- This cap is designed to prevent insects or birds from making their nests in the spout. Unlock it before starting to spray; it will be kept open by the own air flow, without hindering the spray.

- After finishing the spray application, lock the cap again.



AJ-401 LH PLUS

Fan housing cover / Filling unit

> Fan housing cover

- This cover is specifically designed to allow to clean the fan housing; just unscrew it.

**ATTENTION!**

Always clean the fan housing before mounting the sprayer to the tractor to avoid any kind of damage.

- After cleaning, re-install the cover.

> Filling unit

- 1- Set the spout valve lever (1) to turn off.
- 2- Put 5.2 gallons of water in the tank.
- 3- Connect the filling unit hose (3) through quick fitting to the filling unit valve (2) and keep the filling unit (4) at the same height of the valve (2).
- 4- Set the lever of the filling unit valve (2) to the intermediate position so that the hose (3) is completely full of water.
- 5- Set the filling unit valve lever (2) to the working position.
- 6- Put the filling unit (4) in the clean water source.
- 7- Engage the PTO with 540 rpm.
- 8- Set the filling unit valve lever (2) to the filling position.
- 9- After filling, set the filling unit lever (2) back to the working position.

**ATTENTION!**

Only fill the sprayer's tank in places appropriate for this purpose or through appropriate vehicles (trucks, trailers, etc.). Do not collect water from rivers, lakes, dams, streams, brooks, etc. by using the sprayer's return system.

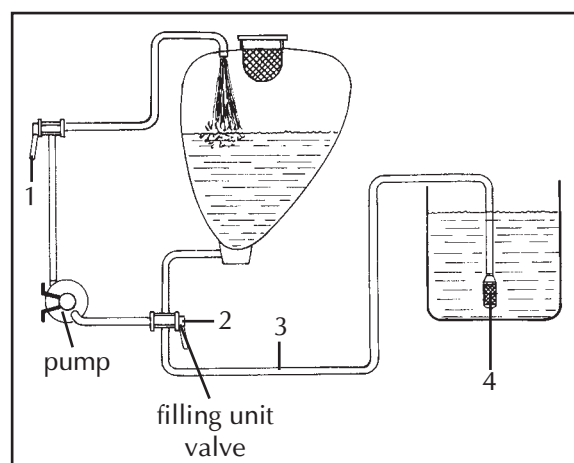
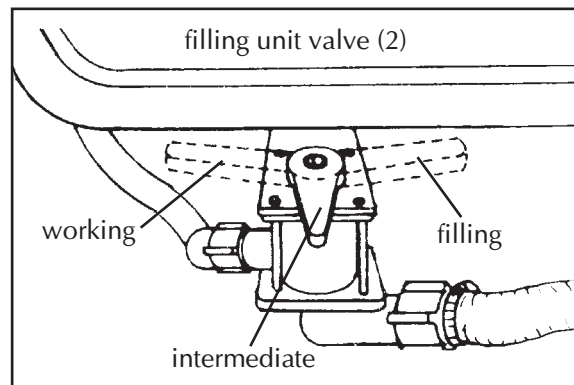
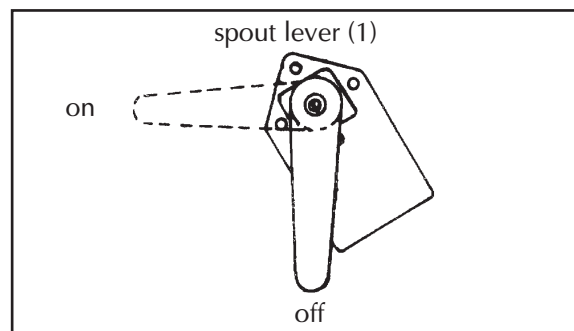



A successful spray application does not depend only on a good sprayer or correct use of the chemicals but also on factors to be determined in the field under specialized orientation.

Among these factors, some concepts should be part of a criterion of evaluation so that positive results may be attained within the pest control program.

- Ideal time
- Safety
- Good coverage
- Application rate
- Sprayer operational condition
- Well trained operator

> Ideal time

The ideal time for spraying should be chosen according to the chemical product characteristics, as well as to the field conditions:

- Infestation level of pests, diseases and weeds;

- Infection level of diseases;
- Growing stage of weeds;
- Weather conditions.

> Safety

When spraying your crops, you must make sure there will be no risk to people, animals and environment. Avoid spraying at hotter times, with humidity below 55% or under windy conditions.

Do not allow the operator to handle chemicals and spraying machinery without the proper individual protective clothing.

> Correct application rate

Any type of application requires that the rate be maintained during the whole spraying work. This will be possible when you have a good sprayer properly calibrated.

This calibration can be obtained through practical methods or formulas. Please refer to the section OPERATION AND ADJUSTMENTS - CALIBRATING THE SPRAYER.

> Good coverage

You have a good coverage when the whole target is sprayed with uniform distribution, with no risk to the environment and with good results in the pest control.

The application rate does not have influence on the treatment results. Therefore good coverages can be attained even with different rates, which may vary according to operational and regional factors.



ATTENTION!

Read carefully and follow strictly the instructions on the chemicals manufacturer's label. Always follow directions of a technician when handling and applying chemicals. Always make sure the sprayer is in good operational conditions before starting the spraying job and employ a well trained operator.



> **Improper conditions to spray**

- With strong wind and high temperature.

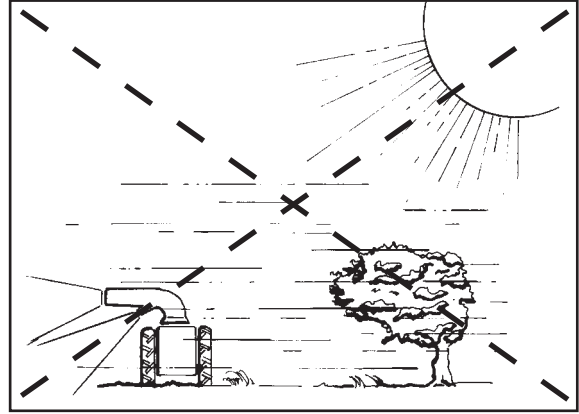

- Against the wind.

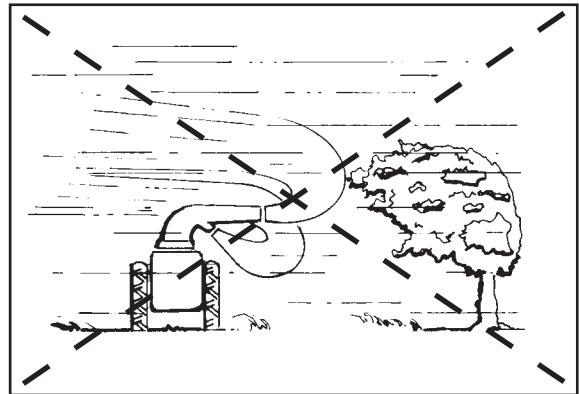

> **Proper conditions to spray**

- Cooler times of the day, that is, early in the morning or late in the afternoon.

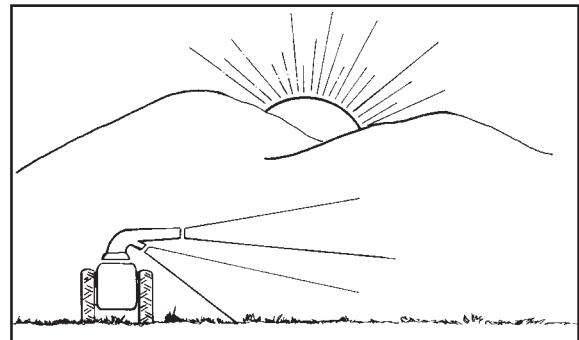

- Always with the (light) wind.

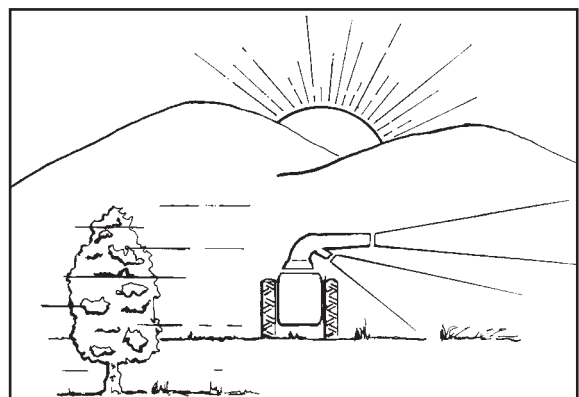



Chemicals	Spray swath (ft)	
	Work beginning	Maximum
Fungicides	50	82
Insecticides	65	100
Herbicides for pasture	50	100

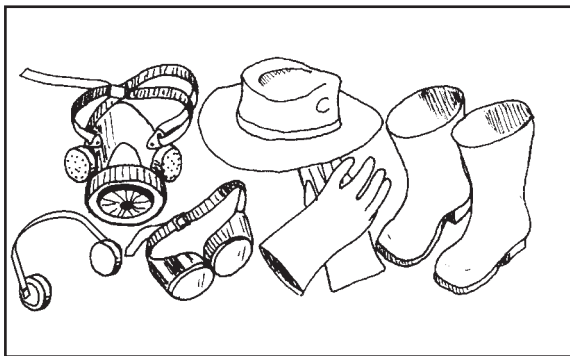

- Select the spray swath according to the plant growing stage, kind of pest or disease, chemicals to be applied and weather conditions.

- The table beside show some suggestions of spray swath. In course of the applications, the operator should determine the spray swath most appropriate to the working conditions.



ATTENTION!

- Always spray at cooler times of the day.
- The rotation of PTO must be 540 rpm.
- Spray with light wind (maximum of 6.214 mph).
- Make sure the swath determined is being sprayed.
- Always use appropriate individual protective equipment such as: working clothes, mask, gloves, etc.

**ATTENTION!**

The safety of people, animals and environment depends on correct spray applications. Therefore, we list below some operational procedures.

WHEN HANDLING THE CHEMICALS

- Follow strictly the instructions on the labels.
- Use individual protective equipment.
- Do not eat, drink or smoke.
- Choose a ventilated place.
- Wash with water and soap the parts of the body touched by chemicals.

WHEN HANDLING THE SPRAYER

- Check for the proper working conditions of the sprayer.
- Do not blow by mouth nozzles, valves or tubes.
- Do not spray against the wind.
- Do not spray in hotter times.
- Use individual protective clothing recommended.
- Do not eat, drink or smoke.

**NOTE:**

You are responsible for the success of the application.

> Calculating the spraying volume through formula

- The sprayer can be calibrated by obtaining the spraying volume through the following formula:

Spray volume (gpa)	Where: GPA - Spray volume (L/ha) GPM - Total nozzles flow rate S - Spray swath (ft) MPH - Tractor speed (mph) 495 - Conversion unit
$\text{GPA} = \frac{\text{GPM} \times 495}{\text{MPH} \times \text{S}}$	
Total nozzles flow rate	
$\text{GPM} = \frac{\text{GPA} \times \text{MPH} \times \text{S}}{495}$	

Example:

Spray volume = 16 gpa

Spray swath = 82 ft

Tractor speed = 2.5 mph

$$\text{GPM} = \frac{\text{GPA} \times \text{MPH} \times \text{S}}{495}$$

$$\text{GPM} = \frac{16 \times 2.5 \times 82}{495}$$

$$\text{GPM} = 6.6$$

**ATTENTION!**

The figures shown in the example above are illustrative only. The correct calibration must be done according to the recommendations of technician.

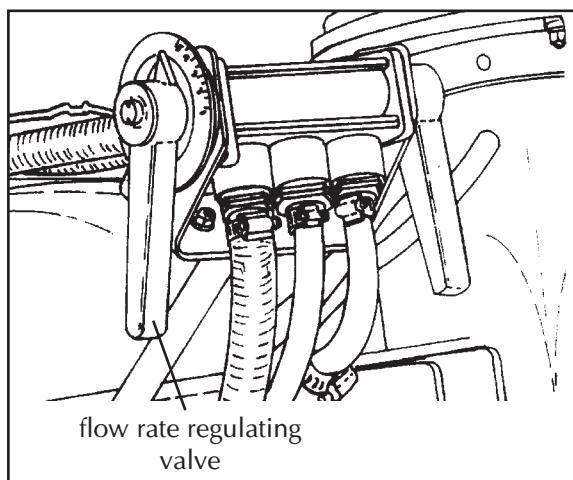

- Different flow rates can be obtained through the setting of the flow rate regulating valve.

> Procedure

- Choose an even ground and level both the sprayer and spout.
- Fill the tank and mark the water level.
- Set the flow rate regulating valve and run the tractor with 540 rpm at the PTO.
- Spray for one minute and again fill the tank up to the level previously marked and note the quantity of water sprayed.
- Repeat this operation several times and take the average.



ATTENTION!

TO INCREASE THE VOLUME:

- Raise the setting of the flow regulating valve.
- Reduce the spray swath.
- Reduce the tractor speed (keep 540 rpm at the PTO).

TO DECREASE THE VOLUME:

- Reduce the setting of the flow regulating valve.
- Extend the spray swath.
- Increase the tractor speed (keep 540 rpm at the PTO).

Calibrate the sprayer so as to achieve the best results without causing damage to the environment.



AJ-401 LH PLUS

Ultra low volume application

- Use:

Flow rate regulating valve setting	0	1,0	1,5	2,0
Flow rate gpm	0.08	0.11	0.15	0.21

Flow rate regulating valve setting	2,5	3,0	3,5	4,0
Flow rate gpm	0.36	0.41	0.42	0.42

**ATTENTION!**

The flow rates above were achieved with the product "Solvente UBV". The flow rate can vary according to the liquid viscosity. So to obtain more actual figures one recommends to determine the flow rate with the agro-chemical to be applied.

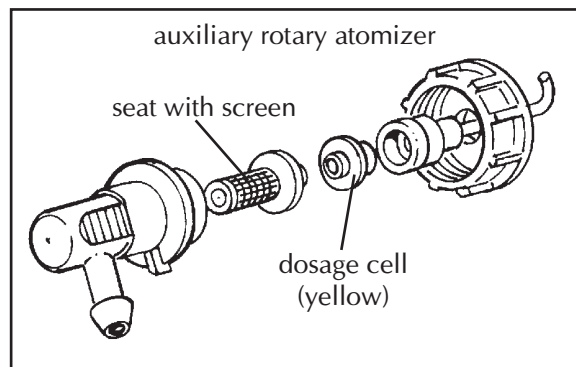
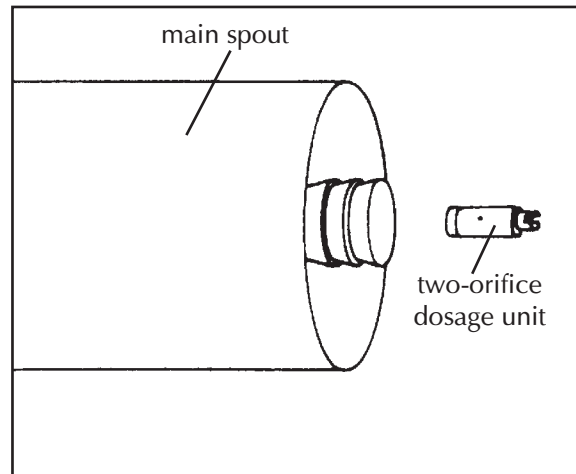
**> Checking the flow rate**

- Unfasten the rotary atomizers.
- Set the flow regulating in the desired position.
- Run the sprayer and collect the chemical flow in a container for one minute. Keep the rotary atomizers at the same level.
- The liquid collected will correspond to the flow rate of the rotary atomizers in liters per minute.

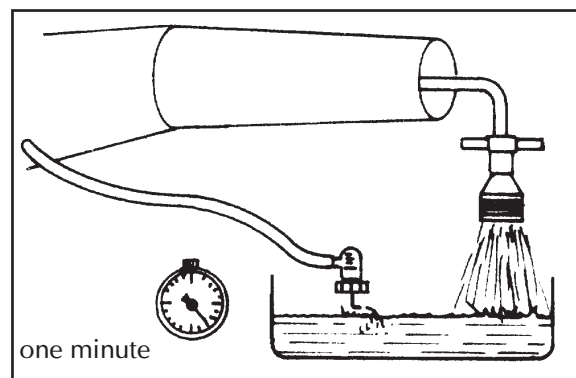
**> Ultralow and low volume application****How to use the table**

- Check the spray swath, tractor speed and spray volume wished.
- The number found in the intersection of the spray volume line with the tractor speed column will correspond to the total flow rate required.

- Next, check in the page before this the flow rate figure which is closest to the flow rate got in the table below to have the setting of the flow rate regulating valve.



Flow rate regulating valve setting	GPM	Spray swath (ft)													
		50							60						
		Tractor speed (mph)													
		1.5	2.0	2.5	3	3.5	4.0		1.5	2	2.5	3	3.5	4	
		Spray volume (gpa)													
0	0.09	0.6	0.4	0.3	0.3	0.2	0.2		0.5	0.4	0.3	0.2	0.2	0.2	
0.5	0.10	0.6	0.5	0.4	0.3	0.3	0.2		0.5	0.4	0.3	0.3	0.2	0.2	
1.0	0.11	0.7	0.5	0.4	0.4	0.3	0.3		0.6	0.5	0.4	0.3	0.3	0.2	
1.5	0.15	1.0	0.7	0.6	0.5	0.4	0.4		0.8	0.6	0.5	0.4	0.3	0.3	
2.0	0.21	1.4	1.1	0.8	0.7	0.6	0.5		1.2	0.9	0.7	0.6	0.5	0.4	
2.5	0.36	2.4	1.8	1.4	1.2	1.0	0.9		2.0	1.5	1.2	1.0	0.8	0.7	
3.0	0.41	2.7	2.0	1.6	1.4	1.2	1.0		2.3	1.7	1.4	1.1	1.0	0.8	
3.5	0.43	2.8	2.1	1.7	1.4	1.2	1.1		2.3	1.8	1.4	1.2	1.0	0.9	
4.0	0.43	2.8	2.1	1.7	1.4	1.2	1.1		2.3	1.8	1.4	1.2	1.0	0.9	

Flow rate regulating valve setting	GPM	Spray swath (ft)													
		75							100						
		Tractor speed (mph)													
		1.5	2	2.5	3	3.5	4		1.5	2	2.5	3	3.5	4	
		Spray volume (gpa)													
0	0.09	0.4	0.3	0.2	0.2	0.2	0.1		0.3	0.2	0.2	0.1	0.1	0.1	
0.5	0.10	0.4	0.3	0.3	0.2	0.2	0.2		0.3	0.2	0.2	0.2	0.1	0.1	
1.0	0.11	0.5	0.4	0.3	0.2	0.2	0.2		0.4	0.3	0.2	0.2	0.2	0.1	
1.5	0.15	0.6	0.5	0.4	0.3	0.3	0.2		0.5	0.4	0.3	0.2	0.2	0.2	
2.0	0.21	0.9	0.7	0.6	0.5	0.4	0.4		0.7	0.5	0.4	0.4	0.3	0.3	
2.5	0.36	1.6	1.2	0.9	0.8	0.7	0.6		1.2	0.9	0.7	0.6	0.5	0.4	
3.0	0.41	1.8	1.4	1.1	0.9	0.8	0.7		1.4	1.0	0.8	0.7	0.6	0.5	
3.5	0.43	1.9	1.4	1.1	0.9	0.8	0.7		1.4	1.1	0.8	0.7	0.6	0.5	
4.0	0.43	1.9	1.4	1.1	0.9	0.8	0.7		1.4	1.1	0.8	0.7	0.6	0.5	

> Example of reading

- Spray swath 75 ft
- Tractor speed 3.5 mph
- Spray volume..... 0.4 gpa
- Flow rate required 0.21 gpm
- Flow rate regulating valve setting 2.0

(according to the table in the page before this)



- Use:

Flow rate regulating valve		
Setting	Flow rate (gpm)	Time to empty the tank (min)
0	3.04	35
1,0	3.43	31
1,5	3.97	27
2,0	5.81	18
2,5	6.87	15
3,0	7.66	14
3,5	8.06	13
4,0	8.19	12

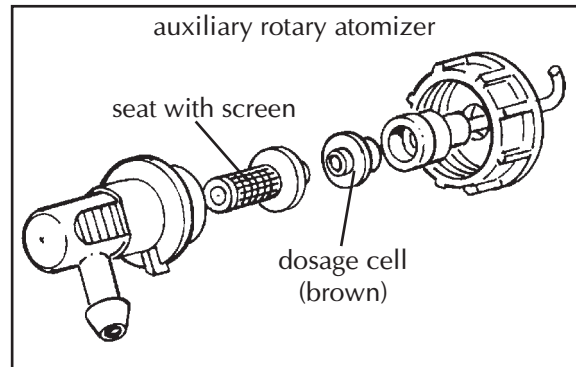
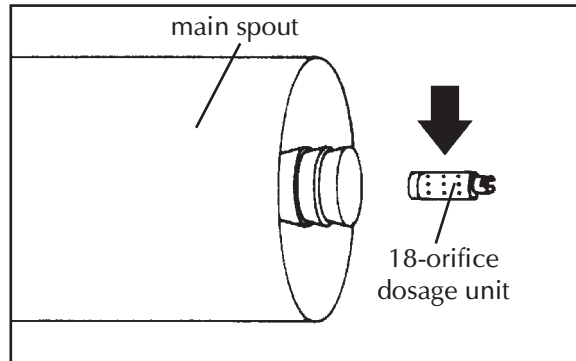



Flow rate regulating valve setting	GPM	Spray swath (ft)											
		50						60					
		Tractor speed (mph)											
		1.5	2.0	2.5	3	3.5	4.0	1.5	2	2.5	3	3.5	4
		Spray volume (gpa)											
0	3.04	20.1	15.0	12.0	10.0	8.6	7.5	16.7	12.5	10.0	8.4	7.2	6.3
0.5	3.17	20.9	15.7	12.6	10.5	9.0	7.8	17.4	13.1	10.5	8.7	7.5	6.5
1.0	3.43	22.6	17.0	13.6	11.3	9.7	8.5	18.9	14.1	11.3	9.4	8.1	7.1
1.5	3.97	26.2	19.7	15.7	13.1	11.2	9.8	21.8	16.4	13.1	10.9	9.4	8.2
2.0	5.81	38.3	28.8	23.0	19.2	16.4	14.4	32.0	24.0	19.2	16.0	13.7	12.0
2.5	6.87	45.3	34.0	27.2	22.7	19.4	17.0	37.8	28.3	22.7	18.9	16.2	14.2
3.0	7.66	50.6	37.9	30.3	25.3	21.7	19.0	42.1	31.6	25.3	21.1	18.1	15.8
3.5	8.06	53.2	39.9	31.9	26.6	22.8	19.9	44.3	33.2	26.6	22.2	19.0	16.6
4.0	8.19	54.1	40.5	32.4	27.0	23.2	20.3	45.0	33.8	27.0	22.5	19.3	16.9

Flow rate regulating valve setting	GPM	Spray swath (ft)											
		75						100					
		Tractor speed (mph)											
		1.5	2	2.5	3	3.5	4	1.5	2	2.5	3	3.5	4
		Spray volume (gpa)											
0	3.04	13.4	10.0	8.0	6.7	5.7	5.0	10.0	7.50	6.0	5.0	4.3	3.8
0.5	3.17	13.9	10.5	8.4	7.0	6.0	5.2	10.5	7.8	6.3	5.2	4.5	3.9
1.0	3.43	15.1	11.3	9.1	7.5	6.5	5.7	11.3	8.5	6.8	5.7	4.9	4.2
1.5	3.97	17.5	13.1	10.5	8.7	7.5	6.6	13.1	9.8	7.9	6.6	5.6	4.9
2.0	5.81	25.6	19.2	15.3	12.8	11.0	9.6	19.2	14.4	11.5	9.6	8.2	7.2
2.5	6.87	30.2	22.7	18.1	15.1	13.0	11.3	22.7	17.0	13.6	11.3	9.7	8.5
3.0	7.66	33.7	25.3	20.2	16.9	14.4	12.6	25.3	19.0	15.2	12.6	10.8	9.5
3.5	8.06	35.5	26.6	21.3	17.7	15.2	13.3	26.6	19.9	16.0	13.3	11.4	10.0
4.0	8.19	36.0	27.0	21.6	18.0	15.4	13.5	27.0	20.3	16.2	13.5	11.6	10.1

> Example of reading

- Spray swath 75 ft
- Tractor speed 3.5 mph
- Spray volume..... 11.0 gpa
- Flow rate required 5.81 gpm
- Flow rate regulating valve setting 2.0

(according to the table in the page before this)



AJ-401 LH PLUS

Tractor path and spout inclination

- The figures below show how to make the spray application and adjust the spout according to the tractor speed and wind direction.

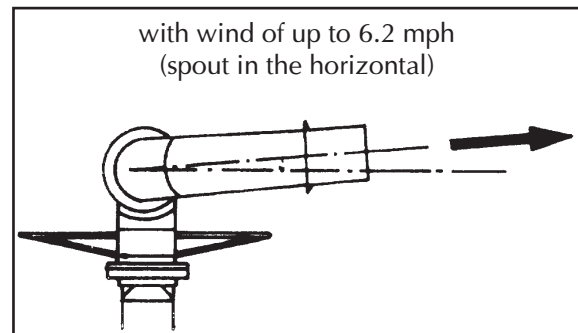
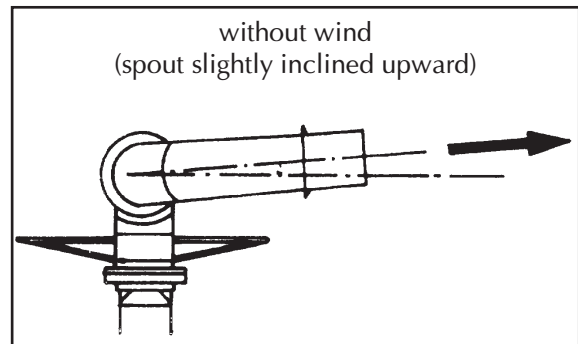
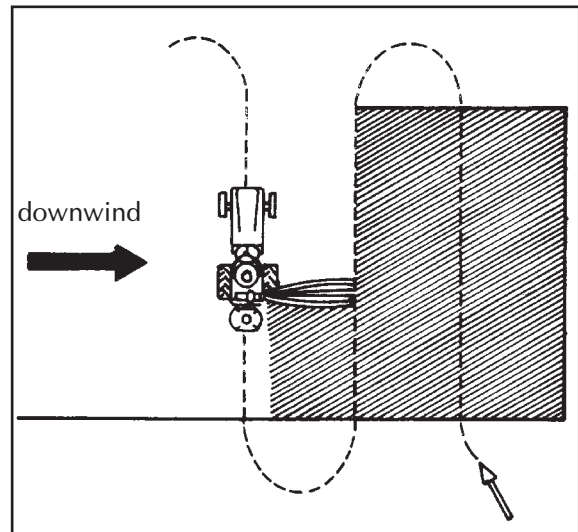

> Adjusting the auxiliary ducts

- Adjust the auxiliary ducts so that the spray covers the area close to the tractor to avoid failures in the application.



ATTENTION!

Turn off the spout before stopping or maneuvering the tractor.
Never spray against the wind.
Never spray with strong wind.
Never spray during the heat of the day.

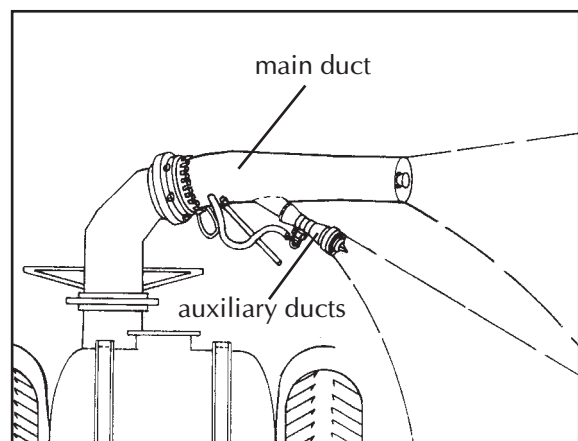



> Calibrating the sprayer through a practical method

Before calibrating the sprayer be sure:

- suction filter is clean.
- hoses are not twisted or bored.
- pressure regulator components (valve seat, valve and spring) are not worn or dirty.

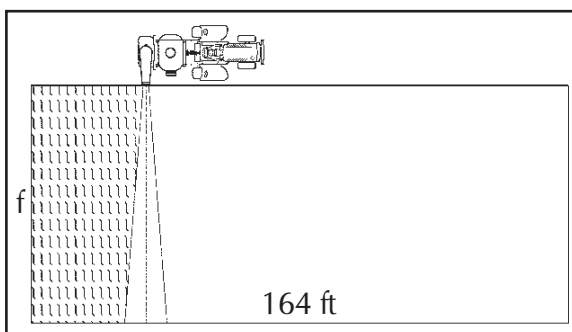
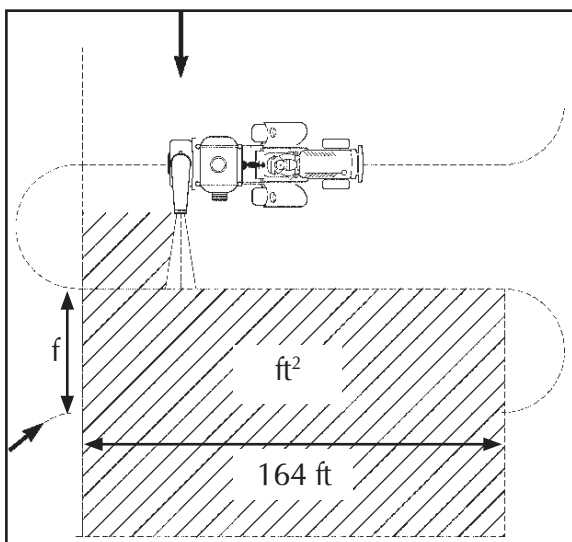
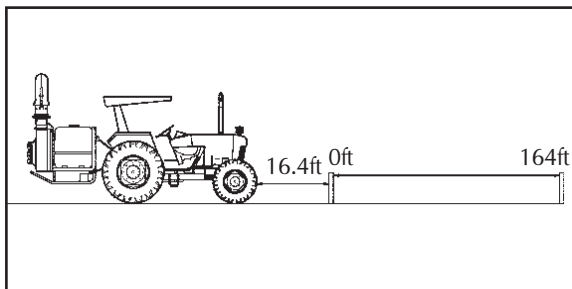

- pump is properly lubricated (oil level and grease) and has no leakage.
- nozzles are of the same model, not worn, with correct flow rate and with clean strainers.

ONCE ALL THE ITEMS CHECKED, START THE SPRAYER CALIBRATION.

- 1 - Mark off 164 feet on the ground to be sprayer.
- 2 - Fill up the sprayer.
- 3 - Start moving at least 16.4 feet before the initial mark.
- 4 - Engage the PTO at 540 rpm.
- 5 - Choose the working gear.
- 6 - Through the Masterflow valve, turn the spraying on.
- 7 - When the machine pass the first mark, start the stopwatch.
- 8 - When the machine pass through the second mark, stop the stopwatch.
- 9 - Note the time it takes the tractor to move 164 feet.
- 10 - On irregular ground, repeat this operation several times and take the average.
- 11 - Measure the application swath.
- 12 - With the sprayer parked on a flat surface, preference the same place where it was filled, complete the tank and measure the spent volume.
- 13 - Calculate the spray volume gallons per acre, through the formula:

$$GPA = \frac{Vol \times 43560}{A}$$

Where:
 GPA = spray volume (gallons per acre)
 Vol = volume spent in the sprayed area
 A = sprayed area (164 ft x spray swath (f) = ft²)

Example:
 Vol = 5 gallons
 A = 164 ft x 65 ft (s) = 10660 ft²

$$GPA = \frac{5 \times 43560}{10660} \quad GPA = 20.4$$



ATTENTION!

When the desirable volume is not reach, increase or decrease the flow, through the valve, or increase or decrease the speed.
 To increase or decrease the speed change gear.



ATTENTION!

To avoid damaging pump, do not run sprayer with less than 14 gallons of water in the tank.

Always use the following individual protective clothing when handling chemicals:

- Impermeable wide-brimmed hat
- Goggles
- Mask
- Long-sleeved working clothes
- Impermeable gloves
- Impermeable boots

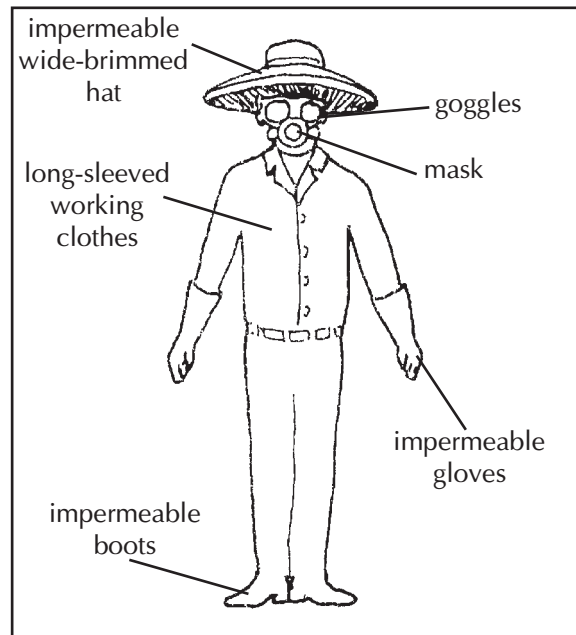

> **Preparing the chemical mixer**

- Read carefully the chemicals manufacturer's label.

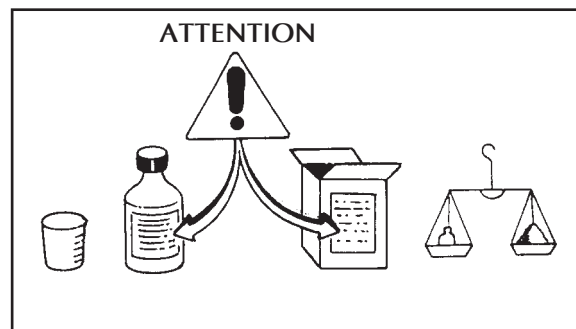

- Pour the chemicals into a bucket with little water and stir.

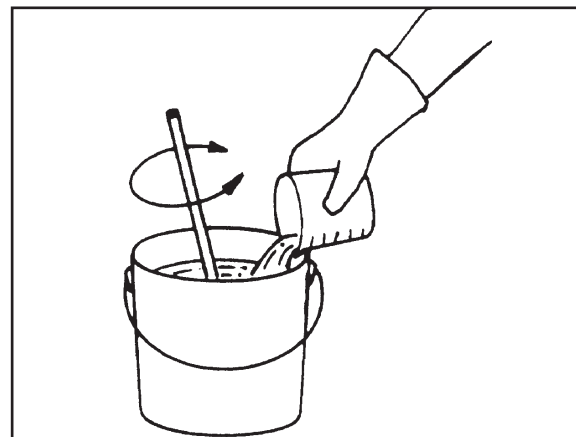

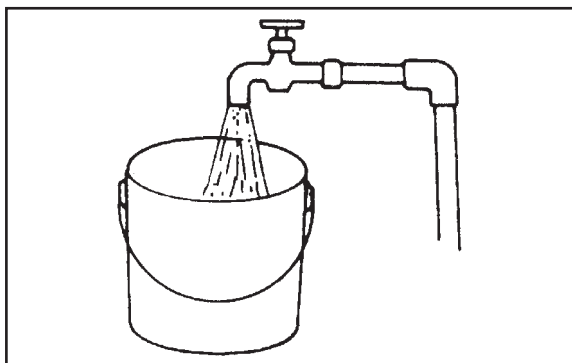

- Add water until filling the bucket up.
- Stir until the chemical and water are mixed.

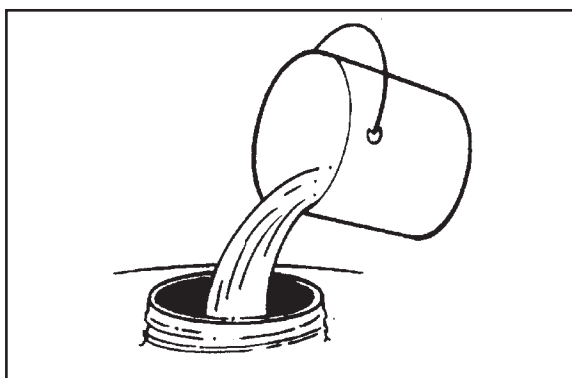

- Pour the solution into the sprayer's tank.
- Install the tank lid and make sure there is no leakage.



ATTENTION!

Always follow technical recommendations when handling chemicals.



AJ-401 LH PLUS

Chemical container rinse

- The chemicals are packaged in appropriate containers for each type of product.
- After emptying the containers, they must be discarded in a safety way, in order not to poison the man and the environment.
- It is very important, before any discard of empty containers, to remove the residues of the product that are stuck inside it and make it useless by piercing it.
- Metal, plastic and glass containers must be rinsed for decontamination.
- To facilitate this important operation, Jacto has installed on its trailed sprayers a suitable device that rinses internally the containers with pressurized water, eliminating most of the residues.

> Procedures

- Fill the chemical tank up to approximately 50% of its capacity.
- Pour the chemical into the tank.
- Engage the tractor PTO.

**ATTENTION!**

The relief lever (1) of the chemical control must be set to allow the chemical return to the tank (off) and the suction filter valve must be with the arrow turned to the main tank. Use the recommended protective clothing for this operation.

- Hold the chemical container over the rinse nozzle and pull the directional valve lever to wash inside the container.

**NOTE:**

With the chemical container over the rinse nozzle, make circular movements to reach all internal walls of the chemical container with the water jet for around 30 seconds.

- Fill up the sprayer tank with water.

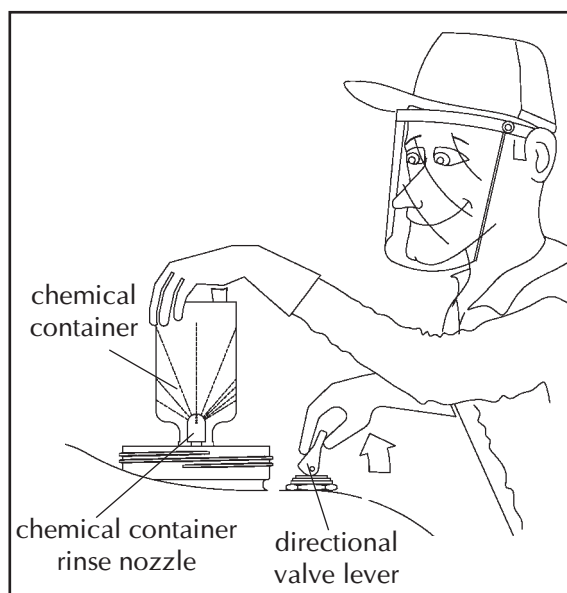
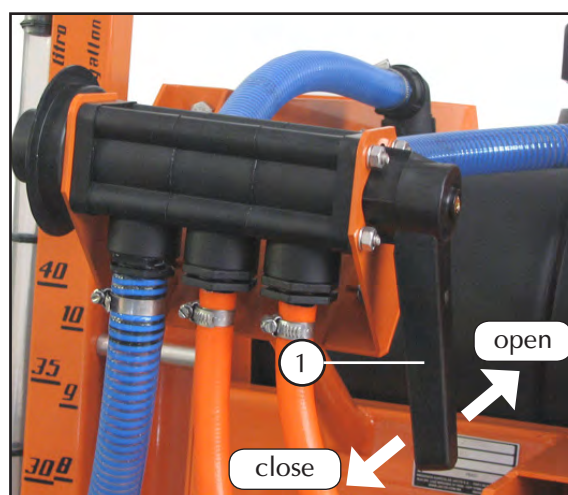
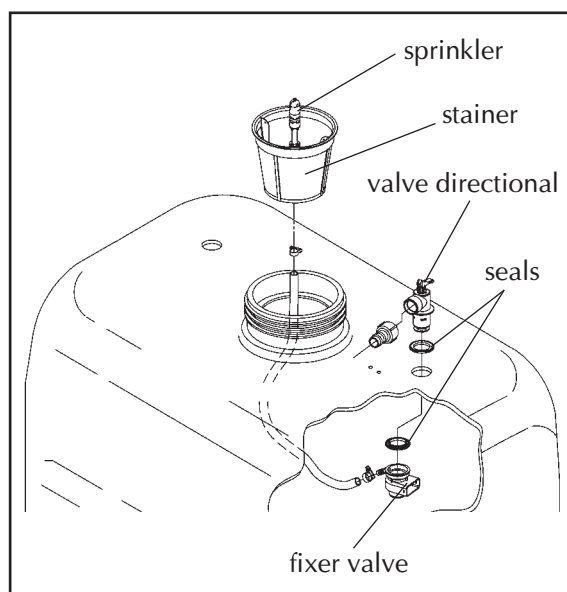

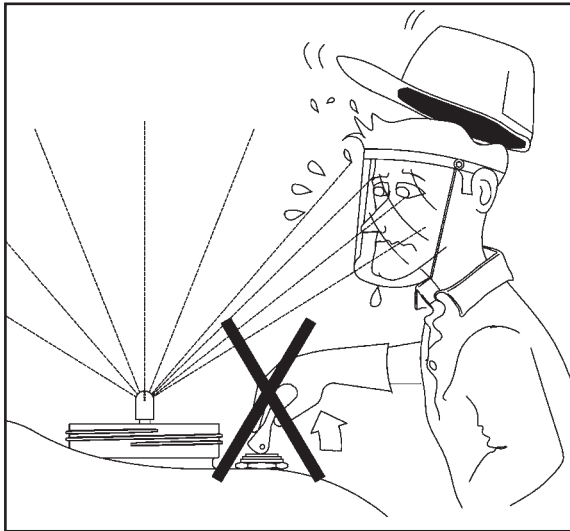

ATTENTION!

Never pull the directional valve without the chemical container over the container rinse nozzle. After rinsing the chemical container, wash it for the last time.

> Washing the chemical container

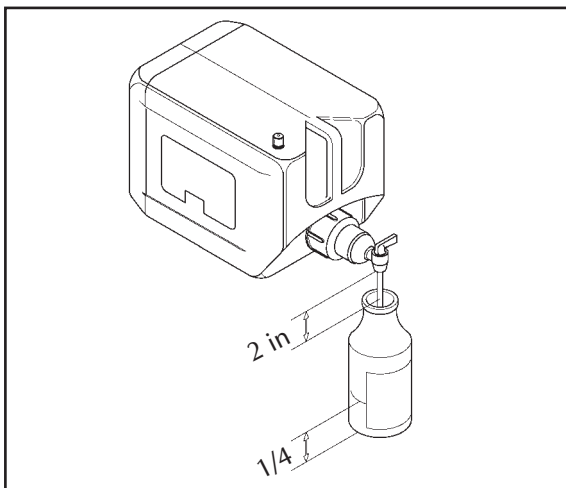

NOTE:

To keep from contaminating the water and the clean water tank tap during the filling of the chemical container, hold the container at least 1.96 in away from the tap and fill the chemical container with water up to 1/4, as shown.



- Fill the chemical container with water up to 1/4. Fit the container cap and tight it enough to avoid leakage during the agitation.
- Shake the container strongly in all ways (horizontal and vertical), for approximately 30 seconds to remove the residues that are attached to the inside of the container.
- Take the container cap off and carefully pour the rinse water into the spray tank.
- Keep holding the container over the spray tank opening until it is completely empty.
- Next, pierce the side of the container so it can't be used anymore. But do not damage the label which identifies the chemical that was inside.



ATTENTION!

Always use appropriate individual protective equipment such as: working clothes, mask, gloves, etc.



After washing the chemical container with the mixture, it is necessary to make the triple wash of the chemical containers as follows:

- Always use individual protective clothing.

**ATTENTION!**

This equipment does not have auxiliary tank to wash chemical containers. The liquid used is the mixture from the tank.

- Fill the container with clean water up to 1/4, fit the container cap and tight it enough to avoid leakage during the agitation.
- Agitate the container strongly in all ways during approximately 30 seconds to remove the residues that are stuck to the container internal walls.
- Take the container cap off and carefully pour the rinse water into the chemical mixer.
- Repeat this operation twice more.
- Make the container useless by piercing with a pointed instrument the container bottom. This way, their labels are not damaged for identification purposes.

**ATTENTION!**

The useless containers can be stocked temporarily in an appropriate place, until final destination.





ADDITIONAL INFORMATION

1- In case of mid and large sized container (13.20, 26.5 and 53 gallons), after washing with the appropriate volume and fitting the cap, roll it on the ground during approximately 30 seconds.

2- In the upright position complete the agitation by moving back and forth for approximately 30 seconds. Empty the container by repeating the same operation to pour the chemical into the spray tank.

Repeat this operation twice more. Make the container useless at the end of the TRIPLE WASH.

Source: ANDEF - ASSOCIAÇÃO NACIONAL DE DEFESA VEGETAL





Guidelines03

Components.....03

Lubrication points.....04

Belt tension.....05

Operations table.....06

Recommended lubricants.....08

Conventional PTO shaft.....09

Winter storage 11

Trouble-shooting 12

General care..... 13

Cleaning and storage 14



- After the first working hours, check if the bolts, nuts, clamps on the tanks, wheel and axle are well installed. Retighten them if necessary.
- Daily, after finishing the spray application, put clean water in the tank, remove the nozzles and run the sprayer till empty.
- Clean and reinstall the nozzles.
- Clean the main filter.
- Rinse off the inside and outside of the sprayer.

- Take off and wash the individual protective clothing separated from other clothes.
- Take a shower with plenty of water and soap and change your clothes.
- These procedures will avoid future problems caused by strainer, nozzle and tube obstructions and prolong the sprayer's life, as well as protect yourself.



ATTENTION!

Never wash sprayers or individual protective equipment in or close to rivers, lakes, streams, brooks, dams, etc.

Always stop the sprayer and turn off the tractor's engine before any kind of maintenance.

> Components - In-line filter

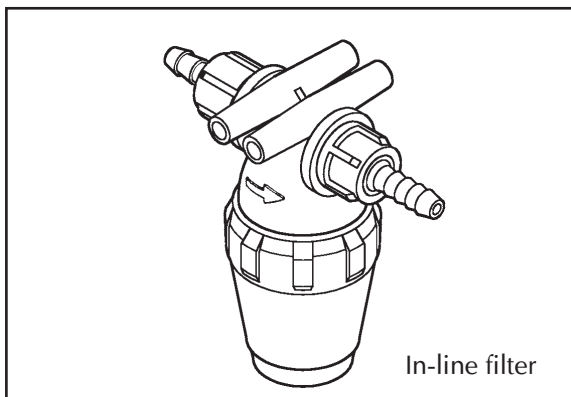

- The frequency of filter cleaning depends on the quality of water and type of chemicals applied.
- Clean the filter when filling the tank or whenever necessary.

> Main spout

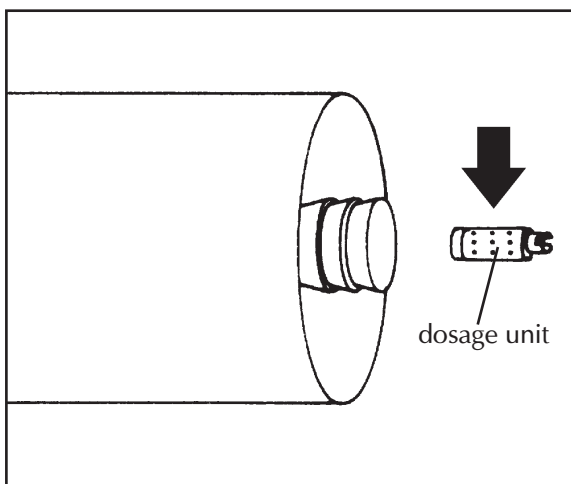

- Remove the dosage unit from the spout daily or whenever necessary.



> Auxiliary rotary atomizer

- Clean the parts of the auxiliary rotary atomizer daily or whenever necessary.

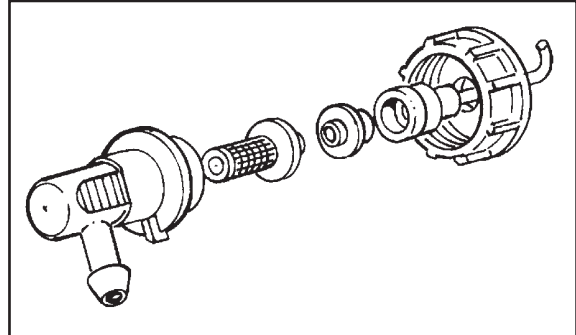

> PTO Shaft

- Lubricate daily.

For instruction in detail, please refer to the section MAINTENANCE - PTO SHAFT.

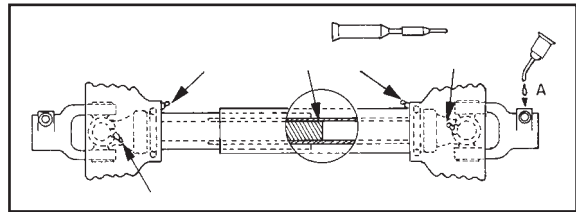

ATTENTION!

Before using the equipment for the first time, clean and lubricate every point of the PTO shaft, as shown in the picture above, with Lithium-based grease NGLI-2 (for further information about the greases, refer to the lubrication table).

> Spout flanges

- Lubricate daily.

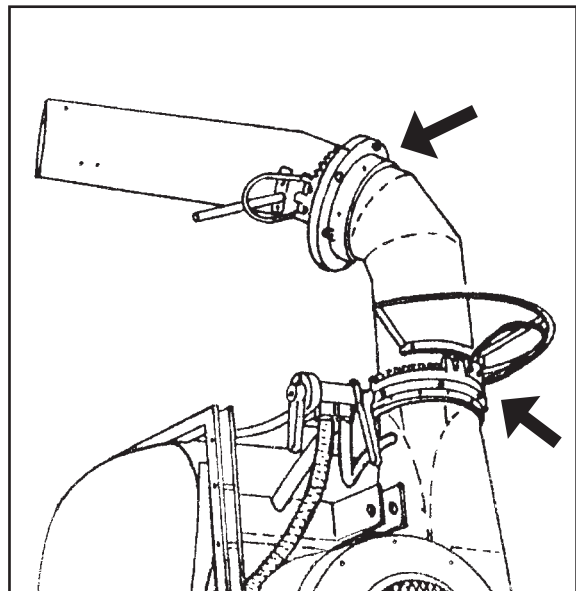



ATTENTION!

Always stop the machine and turn off the tractor before any and all kind of maintenance and use appropriate protective clothing, such as: gloves, boots, goggles, etc.

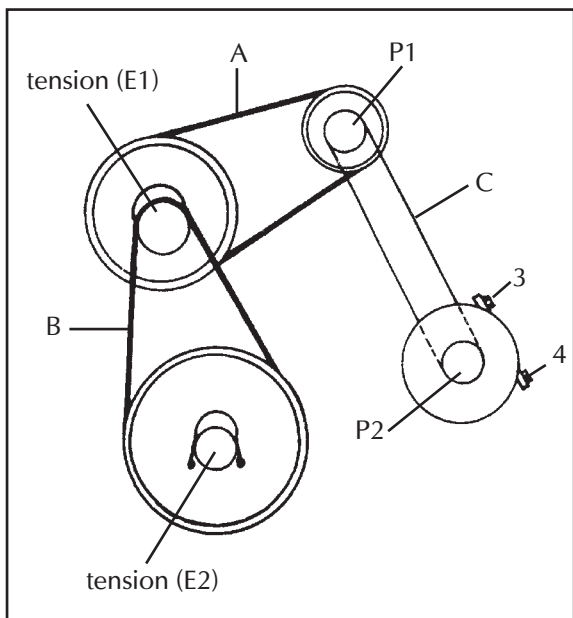
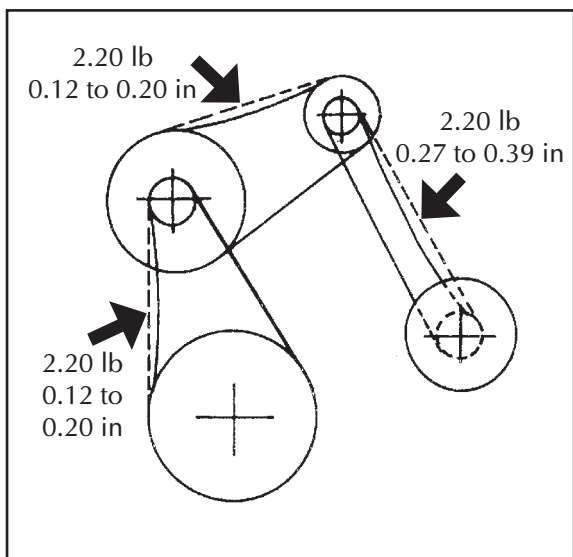

- Check the belts tension periodically. To stretch them proceed as follows:

PROCEDURE

1 - FAN BELT (A)

- Loosen the nut of the tension belt (E2) and slacken the belt (B).
- Loosen (E1) and turn it until obtaining the tension recommended.
- Tighten the nut of the tension belt (E1).
- Turn (E2) until obtaining the tension recommended for the belt (B).
- Tighten the nut of the tension belt (E2).

2 - DRIVE PULLEY BELT

- Loosen the nut of the tension belt (E2) and turn it until obtaining the tension recommended. Tighten the belt nut.

3 - PUMP BELT (C)

- Loosen the screws (3) e (4).
- Slide the pump until obtaining the tension recommended.
- Retighten the screws (3) and (4), observing the alignment of the pulleys (P1) and (P2).



OPERATIONS TABLE	FREQUENCY									
	receiving the sprayer	using the sprayer for the first time	spraying	whenever filling the tank	every day or every 10h	first 30h	every 100h	every 500h or annually	every 1000h	every 2000h
Strictly follow all information contained in this operator's manual.	•									
Check if all components are intact.	•									
Check the components of accessories box.	•									
Require trained person to instruct about assembling, operating and servicing components and accessories.	•									
Clean and lubricate every point of the PTO shaft.		•								
Check if the threee-point hitch pins and cotter pins are original.		•								
Check if the hitch pins have cotter pins.		•								
Check the overlaps of the PTO shaft.		•								
Remove the tractor's drawbar		•								
Adjust the control valve position to avoid impacts while turning.		•								
Check if the grease fittings are filled.		•								
Retighten teh tank nuts and lug nuts.		•								
Use individual protective clothing.			•							
Do not work at high speeds.			•							
Do not spray against the wind.			•							
Take care with electricity supply cables.			•							
Do not eat, drink or smoke while spraying.			•							
After spraying, dispose of all protective clothing and take a shower.			•							
Clean the in-line filters.				•						
If necessary, clean the dosage unit and the auxiliary rotary.				•						



OPERATIONS TABLE	FREQUENCY									
	receiving the sprayer	using the sprayer for the first time	spraying	whenever filling the tank	every day or every 10h	first 30h	every 100h	every 500h or annually	every 1000h	every 2000h
Clean the dosage unit and the auxiliary rotary.					•					
Check the grease fittings and joint pins.					•					
Wash the inside and outside of the sprayer.					•					
Check for damage on the paint and repaint.					•					
Check for chemical leakage and stop it.					•					
Store the sprayer in a dry, ventilated and indoor place.					•					
Retighten the tank nuts and lug nuts.						•				
Remove the covers of the PTO shafts, clean and wash the parts, lubricate and mount the drive shaft.						•				
Tighten the belts.							•			
Clean the inside and outside of the sprayer, and paint the parts subject to corrosion with lubricating oil.							•			
Service the pump.								•		
Retighten the tank nuts and lug nuts.								•		
Replace the belts of the equipment.									•	
Replace the bearings of the drive transmission.										•
Replace the bearings of the driven transmission.										•
If necessary, replace the pressure gauge.										•



RECOMMENDED LUBRICANTS				
COMPONENTS	TYPE	SPECIFICATION	RECOMMENDED PRODUCT	QUANTITY
PTO shaft and spout flanges	grease	Lithium base grease NLGI-2	Multigrak EP-2 (Texaco) MobilGrease 77 (Mobil Oil) Lubrax GMA-2 (Petrobrás) Beacon EP-2 (Esso) and similar products	daily

- The presentation order of the recommended products does not imply preference for any brand or product.



> Use, maintenance, disassembly and assembly of PTO shaft with guard



ATTENTION!

Always stop the sprayer and turn off the tractor engine before servicing the pto shaft. All kind of maintenance on the pto shaft must be done with the use of appropriate protective clothing, such as: gloves, boots, goggles, etc.

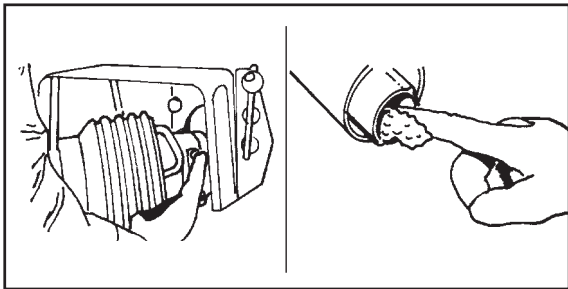

1° - Connecting

- Check the PTO shaft length.
- Adjust the length by cutting the tubes and protection guards proportionately.

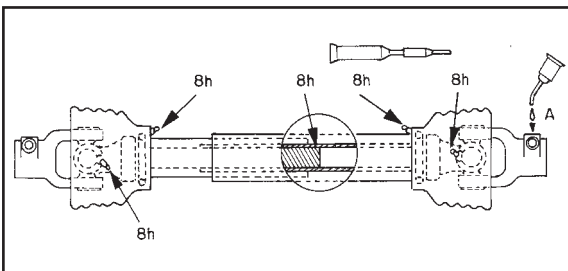

OBSERVATION

File and remove all burrs.

- Lubricate the bars male and female.
- Connect the PTO shaft and install the safety chain.

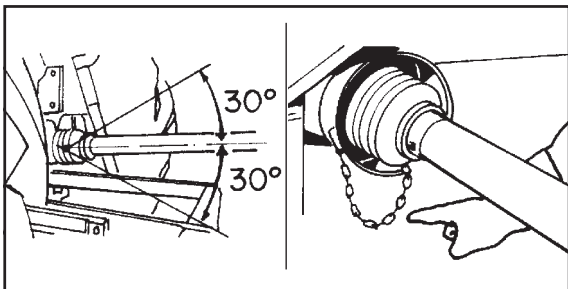

OBSERVATION

Leave some slack on the chain considering angular movements.

- Disengage the PTO when making sharp turns.



ATTENTION!

Only operate with pto shaft equipped with protection guards.



2° - Servicing

a) Disassembling

- 1- Remove the lock screw.
- 2- Turn the guard cone until the indicated position.
- 3- Pull the guard cone.
- 4- Remove the sliding ring.

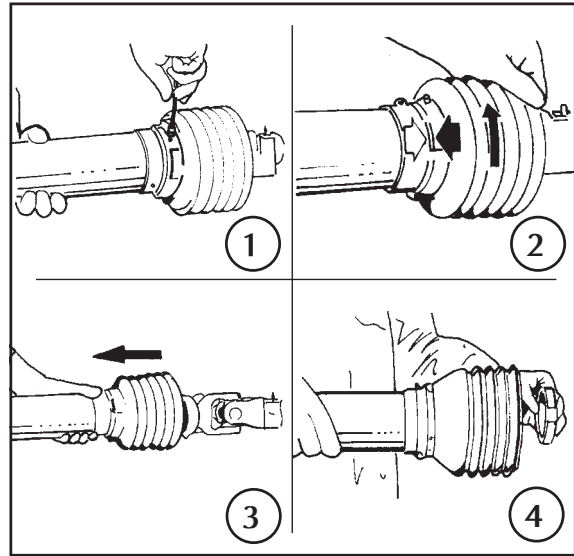

b) Assembling

- 5- Clean and lubricate the male and female tubes.
- 6- Install the sliding ring into the fitting with the grooves pointing toward the tube.
- 7- Install the protection guards.
- 8- Turn the guard cone until the indicated position.
- 9- Install the lock screw.

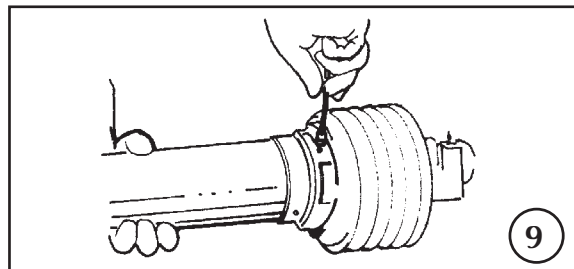
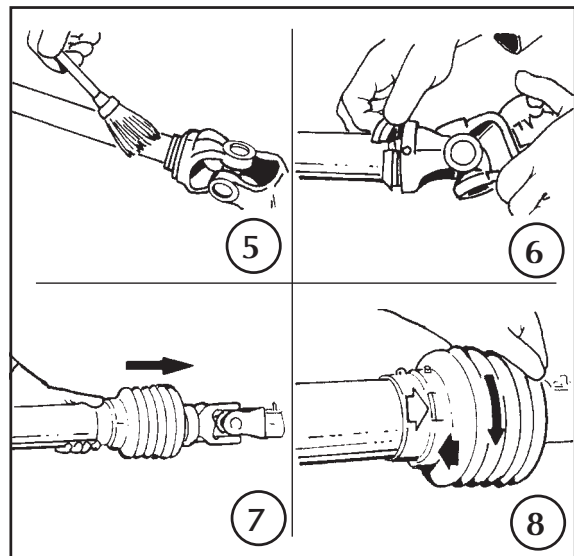



ATTENTION!

In regions where temperatures drop to 32° Fahrenheit or less, the water accumulated in the pump can freeze and cause serious damage.

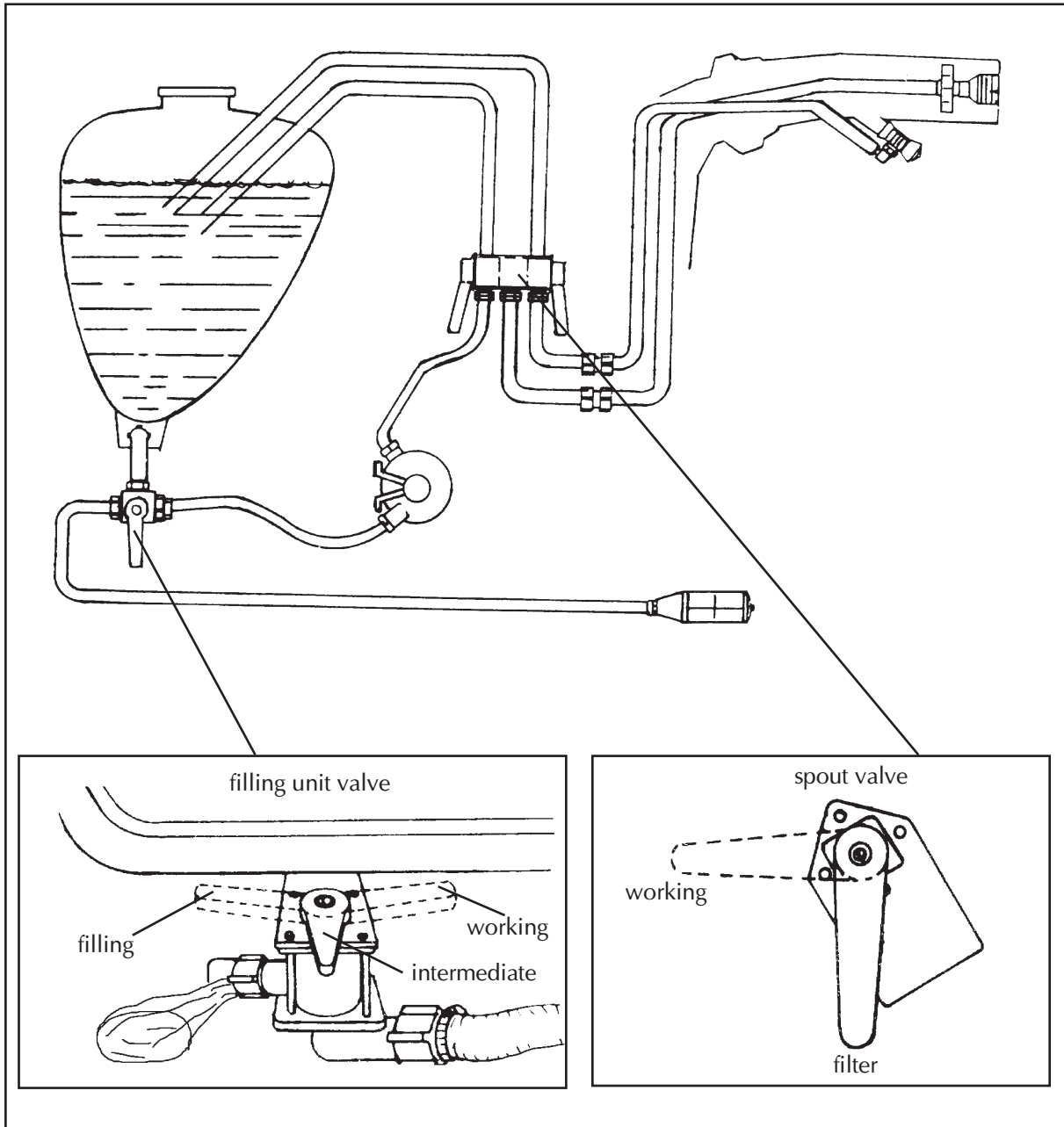

> Procedures

- Empty the tank completely by removing the drain plug and setting the filling valve to the intermediate position.
- Set the control valve lever to turn on so that the water in the circuit flows.
- Check visually if the tank and other components were drained.
- Repeat this operation after every spraying day during the winter.

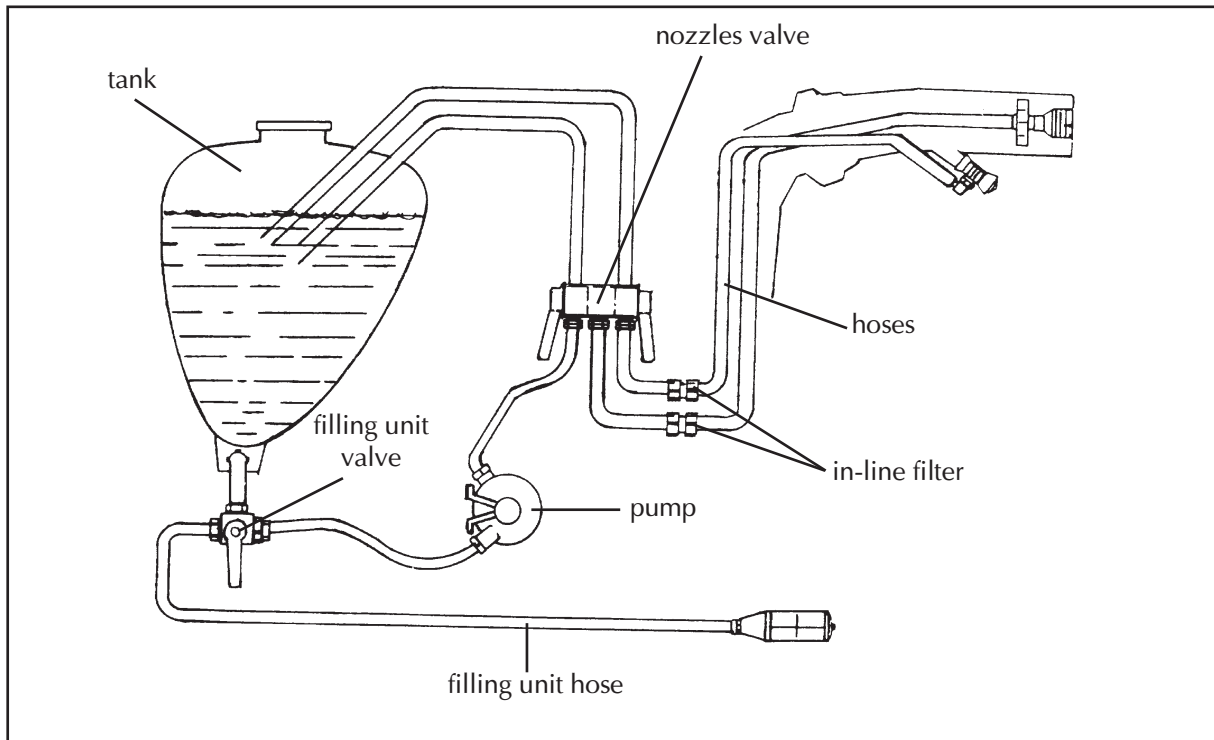

> Problems, causes and corrections

a. Total lack of pressure

INDICATION: No liquid flow.

PROBLABE CAUSES	CORRECTIONS
1. Lack of water.	Fill up the tank.
2. Clogged tank outlet.	Check for impurities in the tank.
3. Dirty filter.	Open the filter shut off valve. If it continues, take the filter cover out and check for impurities in the water flow.
4. Air entering the system.	Verify if all of the connections of the system are well tightened and with o-ring. If it continues, check for damage on the hoses. Replace them if necessary.
5. Pump seal damaged.	Replace the mechanical seal.
6. Position of the filling unit valve lever.	Check if it is set to the working position.

b. Deficient pressure

PROBLABE CAUSES	CORRECTIONS
1. Low PTO rpm.	Increase the PTO rpm to 540.
2. Air entering the system.	See item a-4 above.
3. Pump.	See item a-5 above.



> Handling agricultural sprayers and chemicals

- We warn the owners and users that the UN-REASONABLE USE of this sprayer and chemicals applied may cause damage to people, properties, animals and environment.
- Read carefully and understand thoroughly this manual and the recommendations of the chemicals manufacturers.
- Follow strictly the instructions for proper use of this sprayer and chemicals to ensure more safety and efficiency when spraying your crops.

> After spraying



ATTENTION!

Avoid leaving chemical mixture residues in the tank. For the last pass, prepare the chemical solution in enough quantity to spray the remaining of the crop.

Always follow proper technical guidance.

- Empty completely the tank and wash thoroughly the sprayer in a proper decontamination place.
- Wash the inside and outside of the sprayer with clean water and detergent.
- Disassemble and clean each nozzle assembly with fine brush, water jet or compressed air.
- Dry, lubricate and store the sprayer in a dry and covered place.
- Repaint the damaged metallic parts to prevent corrosion.
- Spray the mettalic parts with lubricating oil to prevent corrosion.
- Take off and wash the individual protective clothing separately from other clothes.



ATTENTION!

Operating this SPRAYER without following the instructions may result in serious injury or death.



- After finishing the work, fill up the tank with clean water (50% of its capacity), remove the nozzles and filters in appropriate place and run the system until draining all the water in order to clean the chemical circuit. Clean the suction filter, the nozzle filters and the nozzles using clean water, neutral detergent and nylon bristle brush (toothbrush). This operation must be made with the use of individual protective clothing (gloves, masks, etc.) and in places where there is no risk of contaminating people, animal, water sources, houses, etc.
- Repaint the damaged parts to prevent corrosion.
- Wash the sprayer externally with clean water and in places where there is no risk of contaminating the environment.
- Store the sprayer in a closed, dry and ventilated place.
- Do not store the sprayer together with foods for people or animals that can be contaminated.
- Do not store the sprayer together with chemicals and fertilizers that can cause corrosion of the sprayer.
- Spray the mettalic parts with a proper protection product or lubricating oil. Do not spray plastic or rubber parts such as tires, nozzle holders, etc. with any kind of solution.
- Make all necessary repairs to maintain the sprayer in good conditions for the next use.

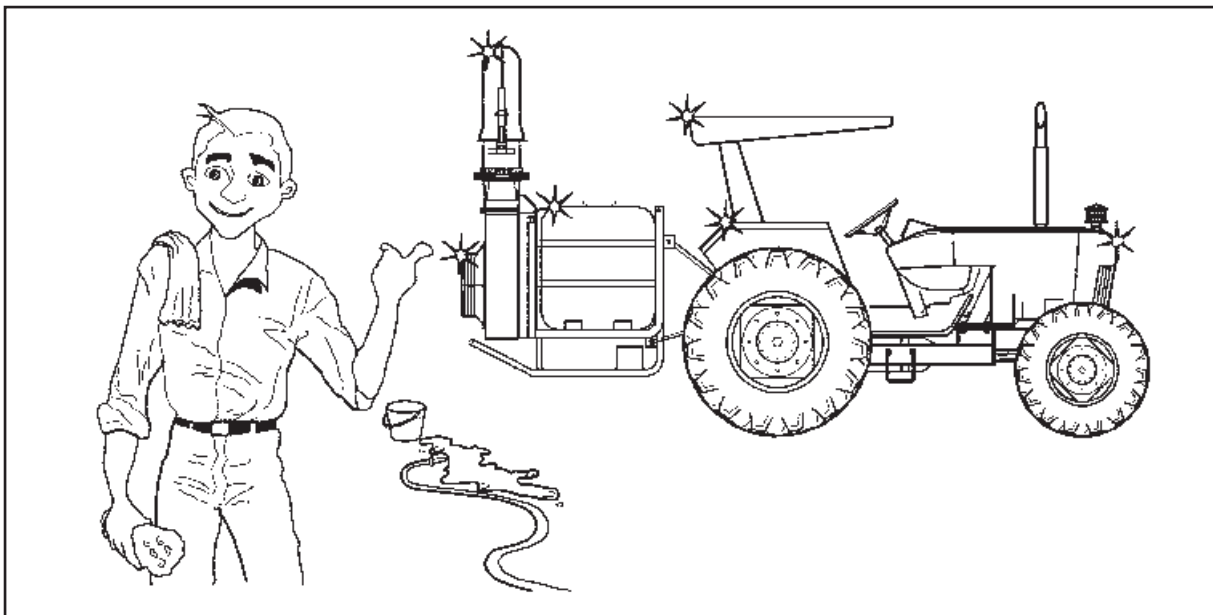

> After cleaning, store the sprayer in a closed, dry and ventilated place





Statement of limited warranty3

Technical inspections registration4



Máquinas Agrícolas Jacto S.A. warrants the equipment described herein and agrees to repair or replace parts and components which, under normal operation and wear, following the technical recommendations, show defects in material or workmanship.

WARRANTY PERIOD: One (1) year from the purchase date by the original retail purchaser.

WARRANTY APPLICATION: Jacto or its authorized representative shall honor this warranty, if any part or component shows confirmed defect in workmanship.

IT SHALL BE UNDERSTOOD THAT THE REPLACEMENT OF COMPLETE COMPONENTS SUCH AS PUMPS, CONTROL VALVES, ENGINES, TRANSMISSIONS, HYDRAULIC PISTONS AND SIMILAR ONES SHALL ONLY BE PERFORMED IN CASE THAT THE DEFECT CANNOT BE REPAIRED BY REPLACING PARTS AND/OR PIECES OF THE COMPONENT.

> This warranty is null and void if:

- Equipment is not used in accordance with the INSTRUCTION MANUAL, overwork or accidents.
- Improper preventive maintenance or performed by unauthorized people.
- Modification of the equipment in any way from the original design.
- Change, damage, or loss of the product identification plate.

- Utilization of parts and components not supplied by JACTO.

PRODUCT REGISTRATION CARD MUST BE COMPLETED BY THE ORIGINAL RETAIL PURCHASER, AND RETURNED TO JACTO DEALER WITHIN 30 DAYS OF PURCHASE DATE.

> Warranty exclusions:

- Parts considered as normal maintenance such as: filtering elements, belts, hoses, nozzles, pistons, pressure gauges, as well as usual maintenance, adjustments, retightening, lubrication and painting.
- Parts which show wear or tear due to use, UNLESS THEY SHOW DEFECTS IN WORKMANSHIP, ASSEMBLY OR MATERIAL.
- Hydraulic, lubricating oils and grease.

- Injuries of personal or material nature to the user, owner, or third parties.
- Additional charges resulting from paralyzation and repair of the equipment.
- Freight charges, pick up and delivery charges.
- Damages of any nature resulting from action of gases or liquids used in the equipment.

> General information

- Defective parts replaced under warranty period shall be property of JACTO.
- Eventual delays in performing services do not confer to the owner the right to indemnity or to extension of the warranty period.
- JACTO reserves the right to change its products or to interrupt manufacturing the equipment.
- THIS LIMITED WARRANTY shall be understood by its expressed terms, and no one in anyway subject to JACTO shall be authorized to modify or amplify the conditions prescribed herein.
- In case of need for warranty request, call for the authorized dealer supplying all information required for a prompt compliance. Do not forget the identification of the equipment, total hours of work, and the noticed defect.

FOR THIS WARRANTY TO BECOME EFFECTIVE the Product Registration Card found in the Instruction Manual must be filled in and returned to your Jacto dealer. THIS CARD MUST BE SIGNED BY THE ORIGINAL RETAIL PURCHASER, INDICATING THAT HE HAS READ AND UNDERSTOOD ALL SAFETY AND OPERATIONAL INSTRUCTIONS IN THE MANUAL. FURTHER THE RETAILING DEALER HAS EXPLAINED TO THE ORIGINAL RETAIL PURCHASER ALL SAFETY INSTRUCTIONS. IN NO CASE WILL WARRANTY BE SUPPLIED UNTIL THIS CARD, PROPERLY COMPLETED AND SIGNED, IS ON FILE WITH JACTO RETAILING DEALER.



PRODUCT REGISTRATION CARD

Invoice number _____ Date ____/____/____

Retailing delaeer _____

Phone _____ City _____ State _____

Sprayer _____ Model _____

Series _____ Sprayer No. _____ Pump No. _____

Original retail purchaser _____

Adress _____ Phone _____

City _____ State _____

Purchase date by the original retail purchaser ____/____/____

The warranty is in force as of this date ____/____/____

Retail purchaser signature _____

Original retail purchaser's copy



PRODUCT REGISTRATION CARD

Invoice number _____ Date ____/____/____

Retailing delaeer _____

Phone _____ City _____ State _____

Sprayer _____ Model _____

Series _____ Sprayer No. _____ Pump No. _____

Original retail purchaser _____

Adress _____ Phone _____

City _____ State _____

Purchase date by the original retail purchaser ____/____/____

The warranty is in force as of this date ____/____/____

Retail purchaser signature _____

URGENT
RESPOND WITHIN 30 DAYS
FIRST CLASS POSTAGE REQUIRED