

# bühler inland

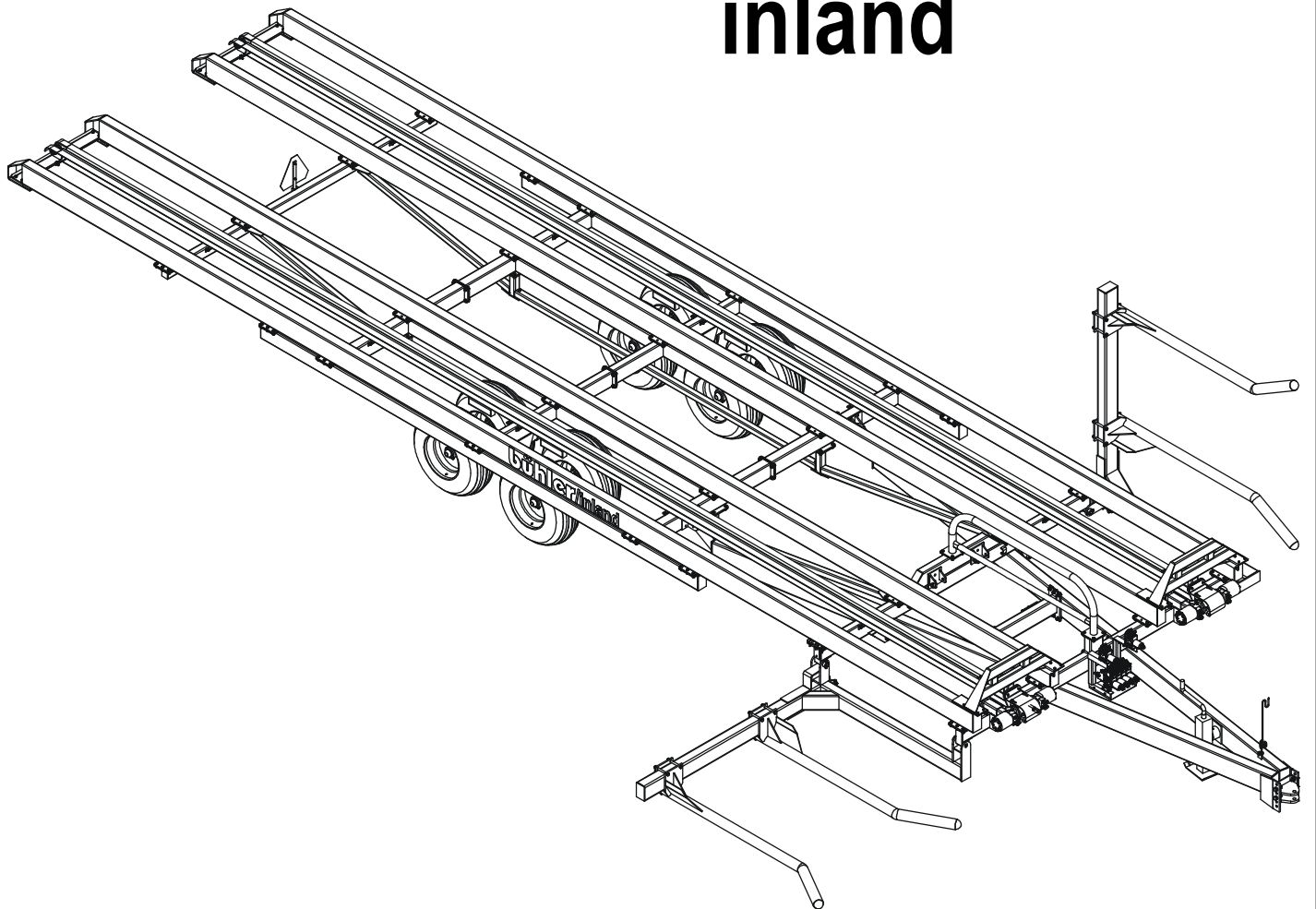

## Model 2500

For serial number 08BM2500001 and later

## Operator's and Parts Manual

Bale Carrier

P4186

04/08

## INLAND WARRANTY POLICY

Buhler Manufacturing products are warranted for a period of twelve (12) months (90 days for commercial application) from original date of purchase, by original purchaser, to be free from defects in material and workmanship under correct, normal agricultural use and proper applications.

Buhler Manufacturing's obligations under this warranty shall be limited to the repair or exchange, at Buhler Manufacturing's option, of any Buhler Manufacturing product or part which proves to be defective as provided. Buhler Manufacturing reserves the right to either inspect the product at the buyer's location or have it returned to the factory for inspection.

The above warranty does not extend to goods damaged or subject to accident, abuse or misuse after shipment from Buhler Manufacturing's factory, nor to goods altered or repaired by anyone other than an authorized Buhler Manufacturing representative.

Buhler Manufacturing makes no Express Warranties other than those, which are specifically described. Any description of goods, including any references and specifications in catalogues, circulars and other written material published, is for the sole purpose of identifying goods and shall conform to such descriptions. Any sample or model is for illustrative purposes only and does not create an Express Warranty that the goods conform to sample or model shown.

The purchaser is solely responsible for determining suitability of goods sold. This warranty is expressly in lieu of all other warranties expressed or implied. Buhler Manufacturing will in no event be liable for any incidental or consequential damages whatsoever. Nor for any sum in excess of the price received for the goods for which liability is claimed.

### **WARRANTY CLAIMS:**

Warranty requests must be prepared on Buhler Manufacturing Warranty Claim Forms with all requested information properly completed. Warranty Claims must be submitted within a thirty (30) day period from date of failure repair.

### **WARRANTY LABOR:**

Any labor subject to warranty **must** be authorized by Buhler Manufacturing. The labor rate for replacing defective parts, where applicable, will be credited at 100% of the dealers posted shop rate. Defective parts will receive an extra 10% discount to assist with freight or other incidental costs.

### **GOVERNMENT LEGISLATION:**

Warranty terms and conditions are subject to Provincial or State legislation.

### **IMPORTANT FACTS:**

**Buckets and Bucket Tines Carry No Warranty**

**Bent Spears Carry No Warranty**

**Snowblower Fan Shafts Carry No Warranty**

**Mower Blades Carry No Warranty**

**Portable Auger Parts Have Two (2) Year Warranty**

**OPERATORS AND PARTS MANUAL****Table of Contents**

<b>Description</b>	<b>Page</b>
TERMINOLOGY AND DECAL LOCATIONS ILLUSTRATIONS.....	2
GENERAL SPECIFICATIONS.....	3
INTRODUCTION.....	4
Serial Decal Location.....	4
Warranty Registration.....	4
SAFETY.....	5
General Safety Notes.....	5
Safety Decals.....	7
Important Precautions.....	8
PRE OPERATION CHECKLIST.....	9
OPERATION.....	10
Attaching Bale Carrier to Tractor.....	10
Attaching Bale Carrier Controls to Tractor.....	10
Carrier Controls Operation.....	12
Loading Bales.....	12
Bale Pusher Operation.....	14
Transporting 2500 Bale Carrier.....	14
Unloading.....	15
LUBRICATION.....	16
Pivot Points.....	16
Roller Chain.....	16
Carrier Beams.....	16
MAINTENANCE.....	17
Fasteners.....	17
Hydraulic System.....	18
Hydraulic Fitting Torques.....	18
Chain.....	19
Wheels/Tires.....	19
Storage.....	20
APPENDIX LIST.....	21
APPENDIX A ASSEMBLY INSTRUCTIONS.....	22
APPENDIX B HYDRAULIC ASSEMBLY.....	26
APPENDIX C ELECTRICAL ASSEMBLY.....	51
APPENDIX D GENERAL ASSEMBLY.....	55
CHECKLIST.....	79
Predelivery.....	79
Customer Delivery.....	79

### TERMINOLOGY AND DECAL LOCATIONS ILLUSTRATION

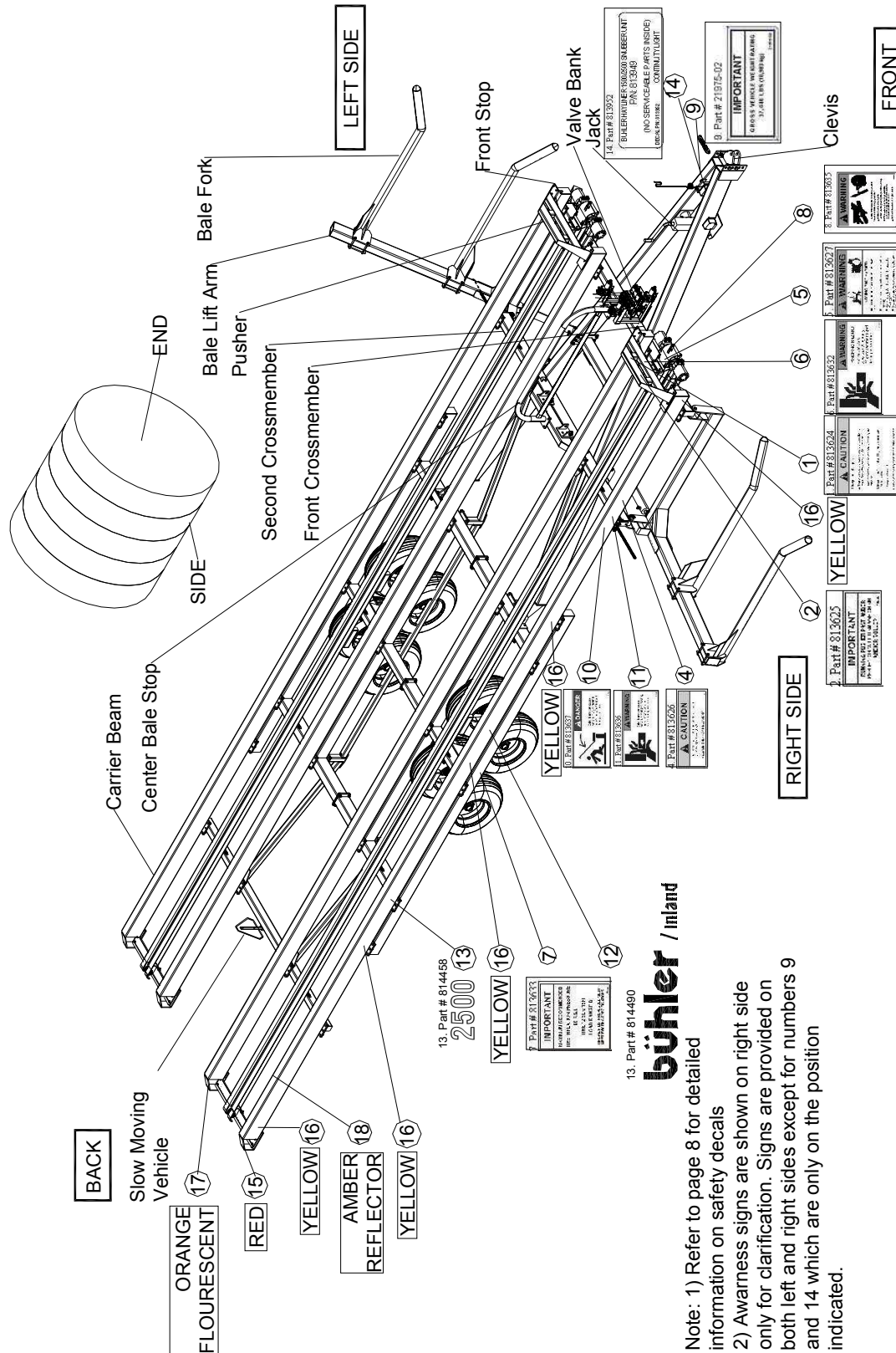

Note: 1) Refer to page 8 for detailed information on safety decals  
 2) Awareness signs are shown on right side only for clarification. Signs are provided on both left and right sides except for numbers 9 and 14 which are only on the position indicated.

**GENERAL SPECIFICATIONS:****Dimensions:**

- Length: 45' (13.7 m)
- Deck Length: 37' (11.3 m)
- Width: 12' 9" (3.9 m)
- Weight (empty): 9,587 LB (4349 kg)
- Drawbar Vertical Load (empty): 2395 LBF (10653 N)
- GVW: 37440 LB (16983 kg)

**Capacity:**

- Total bale payload: 28065 LB (12731 kg)
- Bales up to 6' (1.8 m) diameter maximum to 4' (1.2 m) diameter minimum
- Hay crop, small grains, and flax straw
- Sixteen 4' (1.2 m) wide bales
- Fourteen 5' (1.52 m) wide bales

**Tires:**

- 8-12.5L x 15 FI - 12 ply, Load Range F, Farm Hwy Service tire
- Six bolt heavy duty hubs with twine guards
- Walking beam axle design

**Control Handle:**

- Power: 12v
- Fuse: 15 amp (surge protection provided on machine)

**Hydraulics:**

- Two remote tractor hydraulics circuits required for operation
- Closed-center hydraulic standard.
- In-field configuration is required for open-center or load-sensing tractors
- Two lift cylinders with restrictor
- Two tilt cylinders with restrictor
- Four 22.2 cu. inch (363.79 cu cm) hydraulic motors
- See Appendix B for details on hydraulic components

**Tractor:**

- Size: 100 hp (75kW) recommended
- Weight: As per ASAE specification ASAE S365.4 the tractor must weight 25000 LB (11340 kg) to adequately handle a GVW of 37440 LB (16983 kg)
- Maximum loaded towing speed 20 mph (32 km/h)

## INTRODUCTION

**CAUTION:** Your 2500 Bale Carrier requires a recommended minimum 100 hp (75kw) tractor. The maximum loaded transportation speed of 20 mph (32 km/h) and 37440 LB (16983 kg) must not be exceeded.

This manual has been provided as information regarding the specifications, safe operation and maintenance of your agricultural 2500 Bale Carrier. Read and understand this manual and the tractor manual prior to operating to obtain the best use of operating your 2500 Bale Carrier. Keep this manual for reference and to forward to new operators and owners. Contact your local Buhler Inland dealer if you require any assistance, information or additional manuals.

Your new bale carrier is designed to retrieve, transport, and unload a wide range of round bales. Sizes that can be accommodated range from 4' (1.2 m) diameter to 6' (1.8 m) diameter in a variety of hay crops as well as small grain and flax straw.

### Serial Decal Location

The serial decal is located on the left side of the front crossmember. Please record the serial number in the space provided for future reference. The serial decal will provide the model and date of manufacture of the Bale Carrier and will be required to obtain correct replacement parts and complete warranty claims.

For your records, record  
Serial Number here: \_\_\_\_\_

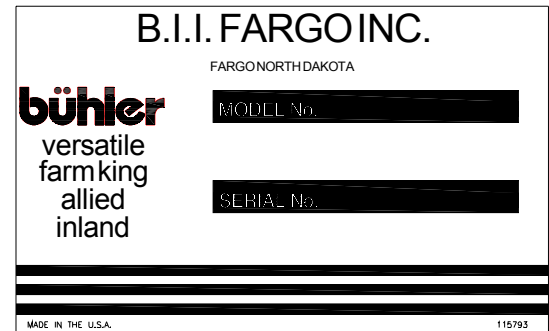

### Warranty Registration

The warranty registration and delivery report **MUST** be completed within thirty (30) days of delivery to validate the warranty.

## SAFETY

Read and understand all the safety messages listed in this manual. For your safety and the safety of others near the machine, learn how to control and operate your 2500 Bale Carrier properly. It is your responsibility to inform subsequent operators and owners of these precautions.

### General Safety Notes

- ✓ Keep young children away from machinery and bales at all times.
- ✓ Be aware that accidents often happen when the operator is tired or in a hurry to get finished. Take the time to consider the safest way. Never ignore warning signs of fatigue.
- ✓ Keep hands, feet, clothing and hair away from moving parts. Never attempt to clear obstructions or objects from a machine while the engine is running.
- ✓ Keep all shields in place. Never alter or remove safety equipment.
- ✓ Do not attempt to clear any blockage or reach into the 2500 Bale Carrier with your arm or leg unless the tractor engine is stopped.
- ✓ Do not load bales of sizes not out lined in the specifications section
- ✓ Use proper lighting and safety warnings when transporting equipment on public roads and during darkness. The slow moving vehicle emblem must be visible. Check with your local law enforcement agency for specific requirements.
- ✓ Provide a first-aid kit for use in case of emergencies.
- ✓ The safety information in this manual does not replace safety codes, insurance needs, or laws governing your area. Be sure your machine meets the standards set by these regulations.
- ✓ Keep a fire extinguisher with the machine. be sure the extinguisher is properly maintained and be familiar with its proper use.
- ✓ Wear close-fitting clothing and cover long hair. Never wear dangling items such as scarves or bracelets.
- ✓ Remember that YOU are the key to safety. Good safety practices protect you and the people around you.
- ✓ Follow all safety messages in the manual and on safety signs located on the machine.
- ✓ It is your responsibility to read and understand this manual completely before operating the bale carrier.

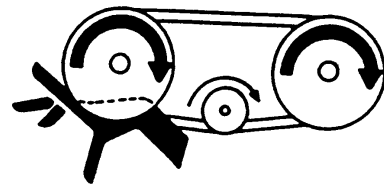

- ✓ Never leave the tractor unattended while the 2500 Bale Carrier is hooked up, always shut tractor off and remove key before leaving the tractor seat. A child or even a pet could engage an idling machine.
- ✓ Keep the 2500 Bale Carrier on solid ground, rocks and holes can be dangerous for operation and movement.
- ✓ Prior to use, check to ensure the attachment is properly hitched.
  
- ✓ Improper use of the 2500 Bale Carrier and tractor can cause serious injury or death.
- ✓ Never operate 2500 Bale Carrier with frayed or damaged hoses or leaking fittings. A burst could cause one or more hydraulic components to behave erratically causing serious injury or loss of life.
- ✓ Operate 2500 Bale Carrier only while seated in the tractor seat.
- ✓ Do not load bales improperly, always load according to the manual's operation procedures.
- ✓ If for some reason you feel the tractor tipping immediately lower lift arms.
- ✓ Do not raise lift arms to extreme heights while tractor is on an incline. Be alert for terrain changes and adjust accordingly.
- ✓ Allow for 2500 Bale Carrier and tractor length when turning.
- ✓ Do not overload the GVW of 37 440 LB (16983 kg) and when loaded keep the speed below 20 mph (32 km/h).
- ✓ Before allowing anyone to operate the machine, for however a short time or distance, make sure they have been instructed in its safe and proper use.
- ✓ Review the manual and all safety related items with all operators annually. correct other operators not using recommended procedures before an accident occurs.
- ✓ When assembling, operating and servicing machinery, wear all the protective clothing and personal safety devices that could be necessary for the job at hand.
- ✓ Never work beneath a raised lift arm unless it is securely supported. The control handle can be moved or a hydraulic leak could cause the arm to drop resulting in serious injury or death.
- ✓ Use only service and repair parts made or approved by the equipment manufacturer. substituted parts may not meet strength, design, or safety requirements.
- ✓ Do not modify the machine. Unauthorized modifications may impair the function and/or safety and affect machine life.
  
- ✓ Keep the area used for servicing machinery clean and dry. Wet or oily floors are slippery. Wet spots can be dangerous when working with electrical equipment. Be sure all electrical outlets and tools are properly grounded.
- ✓ Keep machinery clean. Straw and chaff on hot surfaces are a fire hazard. Do not allow oil or grease to accumulate on service platforms, ladders or controls. Clean machines before storage.
- ✓ Never use gasoline, naphtha or any volatile material for cleaning purposes. These materials may be toxic and/or flammable.
- ✓ When storing machinery, cover sharp or extending components to prevent injury from accidental contact.





## Safety Decals

The *Terminology And Decal Location Illustration* shows the approximate location and detail of safety decals. To install safety decals ensure the installation area is clean and dry. Decide on the exact position before you remove the backing paper. Remove the smallest portion of the split backing paper and align over the specified area. Carefully press in place. Slowly peel back the remaining paper and smooth the remaining portion in place. Small air pockets can be pierced with a pin and smoothed out. Keep all decals clean and replace any that are damaged or missing. Replacement decals are available from you local dealer. The following pictorials indicate important precautions to be used during the operation of the 2500 Bale Carrier.

1. Part # 813624



2. Part # 813625



3. Part # 21867



4. Part # 813626



5. Part # 813627



6. Part # 813632

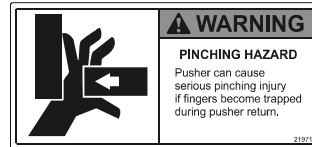

7. Part # 813633



8. Part # 813635



9. Part # 21975-02

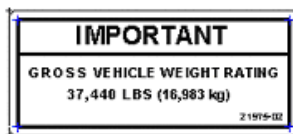

10. Part # 813637



11. Part # 813636

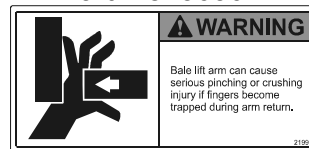

12. Part # 814490

# bühler / inland

13. Part # 814458

# 2500

14. Part # 813952

BUHLER BALE CARRIER 1500/2500 SNUBBER UNIT  
P/N: 813949  
(NO SERVICEABLE PARTS INSIDE)  
DECAL PN: 813952 CONTINUITY LIGHT

15. Part # 967053

RED REFLECTIVE

17. Part # 813631

ORANGE FLUORESCENT

16. Part # 967055

YELLOW REFLECTIVE

18. Part # 813628

AMBER REFLECTIVE

19. Part # A7017-00

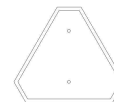

## Important Precautions

The alert symbol is used throughout this manual. It indicates attention is required and identifies hazards and alerts you that your safety is involved. Follow the recommended precautions.

---

 **CAUTION** Indicates a potentially hazardous situation, which may result in injury. It may also be used to alert against unsafe practices.

---

---

 **WARNING** The warning symbol indicates a potentially hazardous situation, which could result in death or serious injury and includes hazards that are exposed when guards are removed. It may also be used to alert against unsafe practices.

---

---

 **DANGER** The danger symbol indicates an imminently hazardous situation, which will result in death or serious injury. This signal word is limited to the most extreme situations, typically for machine components, which for functional purposes, cannot be guarded

---

**PRE-OPERATION CHECKLIST**

---

**⚠ CAUTION** Make sure the tractor has a 100 hp (75 kw) or greater rating and a mass of 25000 LB (11340 kg). Make sure the drawbar is capable of supporting the 2500 Bale Carrier empty or loaded.

---

**⚠ WARNING** The tractor must be equipped with an approved Roll over Protection Structure (ROPS) and safety belts to help prevent personal injury or death caused by tractor roll over.

---

To ensure safe and proper operation of the 2500 Bale Carrier, inspect the following items prior to operation and daily thereafter. Refer to operation, lubrication and maintenance sections for detailed instructions.

- ✓ Prior to first use verify that the 2500 Bale Carrier has been properly assembled and that the operator understands the safety, operating, and maintenance requirements.
- ✓ Check for missing fasteners and replace if necessary. Refer to maintenance section for details.
- ✓ Check and maintain proper tire pressure of 90 psi (620 kpa).
- ✓ Check for loose wheel bolts. Bolts must be torqued to 125 ft LB (170 Nm).
- ✓ Clean 2500 Bale Carrier of any foreign material that may have accumulated from previous run.
- ✓ Lubricate all points requiring daily lubrication.
- ✓ Check chain tension and adjust if necessary with front sprocket adjusting bolt (approximately 6" (15 cm) of upward slack). This is verified by raising the chain by hand.
- ✓ Ensure top surface of bale carrier beams are properly coated with a graphite coating to reduce bale friction while pushing bales back.
- ✓ Ensure that the tractor used to pull the 2500 Bale Carrier is in working order according to the tractor manual.
- ✓ Verify the 2500 Bale Carrier is properly coupled to the tractor with the safety chain.
- ✓ Inspect all safety reflective decals, slow moving vehicle decals and lights where applicable.
- ✓ Inspect the hydraulic system on the 2500 Bale Carrier and your tractor for leaks or any other damage.
- ✓ Ensure the control handle actions reflect the movements of the 2500 Bale Carrier.
- ✓ Inspect all electrical connections to ensure proper function of the machine
- ✓ Ensure transport safety chain is disengaged from bale lift arm and stored on chain lug located on second cross member. Failure to do so may cause damage to lift arm.

**OPERATION**

---

**⚠ CAUTION** Prior to operation ensure the operator has read and understands the safety requirements of the 2500 Bale Carrier. Ensure the pre-operation checks have been completed prior to operation.

---

**1. Attaching Bale Carrier To Tractor**

---

**⚠ CAUTION** Shut off tractor, engage parking brake and remove key before working around 2500 Bale Carrier. Refer to tractor manual for tractor parking procedures.

---

---

**⚠ CAUTION** Use only the drawbar to couple the 2500 Bale Carrier to the tractor. Ensure drawbar is capable of handling the 2500 Bale Carrier load. The tractor must have a minimum mass of 25000 LB (11340 kg) and recommended 100 hp (75 kw).

---



- Using the tongue jack, raise tongue to align with hitch pin, adjust clevis position as necessary to level the carrier beams.
- Position tractor and secure with locking type drawbar pin (not supplied). Use an approved hitch pin with a mechanical retainer.
- Route safety chain around the hitch clevis, around drawbar support and back hook. Refer to tractor manual for further drawbar instructions.
- Do not use intermediate support on drawbar as attaching point.
- Store safety chain off the ground when not in use. If safety chain is damaged in any way, contact your dealer for a replacement.
- For serial number **08BM2500001** and later, open-center valve is a factory-installed feature
  - **Note:** The bale carrier is factory-configured to operate with tractors having CLOSED-CENTER hydraulic systems (page 27).
- **For tractors with OPEN-CENTER or LOAD-SENSING hydraulic systems, refer to the configuration on pages (29, 46 and 47).**

**2. Attaching Bale Carrier Controls To Tractor**

- Bale raise and push functions are controlled by the 2500 Bale Carrier valve. Pressure and tank are supplied by two hoses complete with black hydraulic tip covers. The retract hose is designated with a check valve and ensures proper flow through the valve. Connect tank hose to retract circuit and extend hose to opposite extend port see *Appendix B* for schematic.
- The tilt function is controlled by the tractor's remote valve. Extension and retraction are supplied by two hoses complete with red hydraulic tip covers.
- Connect control handle harness to the machine harness. Connection is made at the snubber unit by matching the appropriate socket and plug.

- The power required to operate the 2500 Bale Carrier is supplied by the tractor's 12-volt electrical system. Connect the red wire to the tractor positive and green to tractor ground. Connection may be made via tractor accessory plug or alternate method. The 15 amp fuse must be used on the positive wire as supplied.
- Verify 2500 Bale Carrier operation matches 2500 Bale Carrier control handle decal.

### 3. Carrier Control Operation

- To begin 2500 Bale Carrier operation engage the remote hydraulic valve in the extension position. Lock valve in detent. Valve to remain constantly on during operation.
- The control handle is fitted with one (1) rocker switch and four (4) momentary contact rocker switches. They function as follows:
  - **PUSHER SPEED:** Select  (HIGH) to operate pusher motors in series at high speed or  (LOW) to operate in parallel at low speed. Torque is increased at low speed and pushes bales with more force.
  - **RH PUSHER:** Depress and hold RH PUSHER FWD to move right forward. Depress and hold RH PUSHER BACK to move right pusher back.
  - **LH PUSHER:** Depress and hold LH PUSHER FWD to move left pusher forward. Depress and hold LH PUSHER BACK to move left pusher back.
  - **RH LIFT ARM:** Depress and hold RH LIFT ARM UP to raise right lift arm. Depress and hold RH LIFT ARM DN to lower right lift arm.
  - **LH LIFT ARM:** Depress and hold LH LIFT ARM UP to raise left lift arm. Depress and hold LH LIFT ARM DN to lower left lift arm.
- To operate raise / lower tilt function engage the remote hydraulic valve in the extension position to raise the tilt deck and engage the retract position to lower the deck.

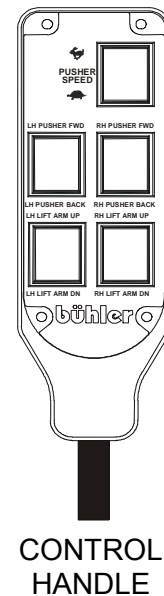

### 4. Loading Bales

**⚠ WARNING** Make sure area is clear before lowering bale lift arms. Failure to do so could result in injury or death.

- The right bale lift arm is used to load bales onto the right side of the carrier while the left bale lift arm is used to load bales onto the left side of the carrier.
- Align the tractor and 2500 Bale Carrier as indicated in the pictoral for pick up method used. Slowly approach the bale at 5 mph (8 km/h) while loading. When bale is properly captured begin to raise the bale.
- To balance the 2500 Bale Carrier, alternate bale picking sides.
- The 2500 Bale Carrier is designed to load bales with one of three options. Refer to the appropriate section on the next page for your option loading instructions. Instructions for the fork positions are provided in appendix A.

**NOTE:** Before loading bale the pusher must be at the front of the carrier deck.

- The **Fixed Pick Up Arm** requires the operator to drive at 90° to the baling direction. The bales are loaded “End On”. The bale is loaded onto the carrier deck by depressing and holding LH or RH LIFT ARM UP until the bale rolls off the pickup arm and onto the carrier beams.
- The **Bale Deflector** attached to the fixed pick up arm allows the bales to be picked up from either “End On” or “Side On.” The deflector rotates the bale 90° before it is lifted up onto the carrier. Forward travel is used to rotate the bale. Approach the bale so that the outer end of the bale rides up on the bale deflector as the loading arm moves under the bale.

To pickup bales that are placed “End On,” drive so the inner arm of the loading fork is against the inner edge the bale. The bale will then be loaded onto the carrier in the same direction as it was picked up. Continue to load using fixed arm instrucionts.

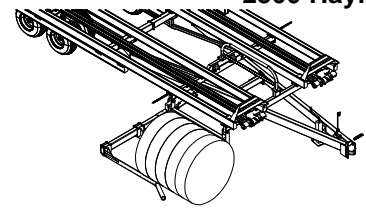

FIXED PICK UP ARM

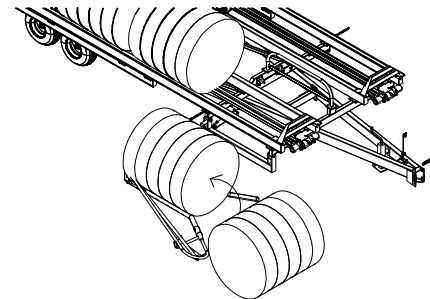

BALE DEFLECTOR

---

**NOTE:** The bale should be contacted about 12” (30 cm) from its outer end when using the bale deflector. Contacting the bale further to the inside may result in damage to the deflector, bale lift arm or bale.

---

- The **Rotating Pick Up Arm (RPU)** loads bales “side on”. The lift arm starts in the lowered position. Drive forward until the forks are positioned around the ends of the bale with the inside stationary fork as close as possible to the bale. Depress and hold LH or RH LIFT ARM UP. The bale is then squeezed on end until the pressure matches the sequence valve setting that rotates and raises the bale.

When the bale is raised above the beam release by depressing LH or RH arm down. This releases the bale and returns the RPU to the ready state for the next bale. Refer to the assembly instructions for adjusting RPU’s settings.

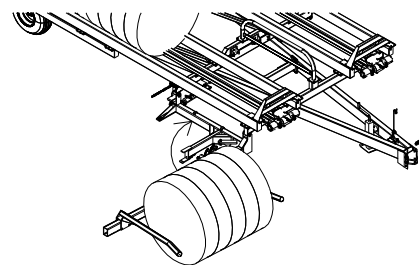

RPU LOADING BALE

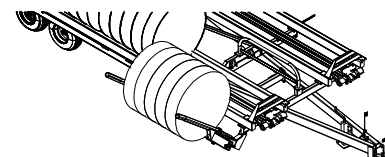

RPU RAISING BALE

## 5. Bale Pusher Operation

**⚠ CAUTION** To avoid misbalanced loads the operator is only required to push back one bale length to prepare for the next bale.

**NOTE:** Lower loading arm before operating the pusher.

- Depress and hold LH or RH PUSHER BACK and move bales far enough to the rear to provide room to load the next bale.
- Return pusher all the way to the front by depressing and holding LH or RH PUSHER FWD.
- Hi speed / Low torque mode is recommended for normal use.
- Low speed / High torque mode is for heavier payloads or situations where bales are wet or resist sliding.

## 6. Transporting 2500 Bale Carrier

**⚠ WARNING** Do not tow over 20 mph (32 km/h) when loaded. Turn on flashing lights when transporting on public roadways. Obey local regulations regarding road transport. Raise bale lift arm and use the safety chain when transporting. Ensure the lift arm chain latch is used to prevent the safety chain from dislodging or loosening.

- Do not transport if end bale is overhanging beams. Beam should extend beyond last bale for a minimum of 2' (61 cm).
- Raise left and right lift arms prior to transport. Always engage lift arm safety chains when transporting on public roadways or when not in field. Lock chain in position with latch provided.
- Monitor the condition and position of bales that are being transported.
- Slow speed when transporting over bumps or rough terrain.

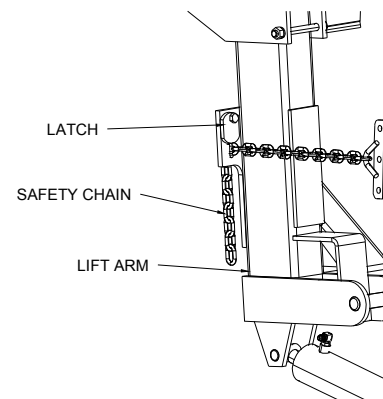

LIFT ARM SAFETY CHAIN  
ILLUSTRATION



## 7. Unloading

**⚠ DANGER** Make sure area is clear before unloading. Failure to do so could result in serious injury or death.

**NOTE:** Left or right decks can be unloaded individually or together. However, the pusher moves faster and has more torque when operated individually. Do not run pushers all the way to the end, the resulting shock load may cause damage to chain and drive.

- Extend tilt cylinder to raise carrier beams by engaging the tractor's extension hydraulics.
- Depress and hold LH and/or RH PUSHER BACK switch to push the bales off the carrier beam.
- Once the rear bale has been pushed off the carrier, slowly drive forward while pushing the bales back (unloading) to keep all bale ends in contact.
- When amber reflector on inside of the carrier beam becomes visible stop the pusher. The reflector is approximately 26" (66cm) from the end of the beam.
- Slowly drive forward to unload the last bale. Retract the tilt cylinder to lower the beam and begin the next loading cycle.
- Return PUSHER to the front of the 2500 Bale Carrier to prepare for the next cycle.

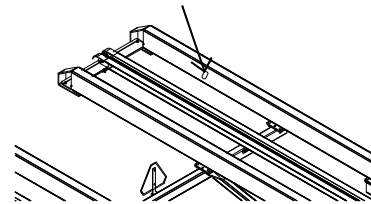

AMBER REFLECTOR  
LOCATION

## LUBRICATION

**⚠ CAUTION** Place all controls in neutral, stop engine, set parking brake and remove ignition key before inspecting, servicing, adjusting or repairing the 2500 Bale Carrier.

**⚠ CAUTION** Ensure the 2500 Bale Carrier tires and hitch are securely block. Otherwise, verify the 2500 Bale Carrier is properly coupled to the drawbar on a tractor with a minimum mass of 25000 LB (11340 kg).

### Pivot Points

- Lubricate 2500 Bale Carrier bushings and pivots every eight hours of average operation with high-grade grease at all fitting locations. Select grease based on the expected outside temperature range. Lithium, Molybdenum and synthetic greases are preferred. Use the tractor hour meter as a guide. Increase lubrication intervals for extreme use or adverse conditions. Each pivot should be lubricated until grease is visible at pin. The fixed arm carrier has 16 lubrication points and the RPU carrier has 18 points. Refer to the illustrations below for locations.

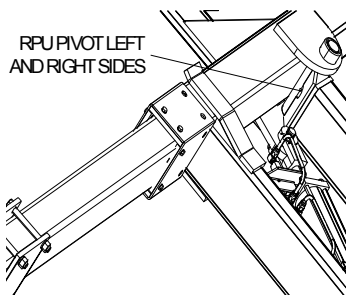

RPU LUBRICATION ILLUSTRATION

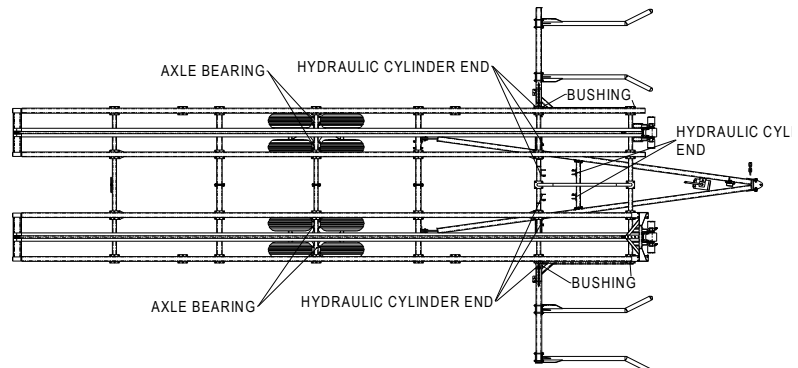

LUBRICATION ILLUSTRATION

### Roller Chain

- Manually brush an SAE lubricant while chain is stationary.
- Lubricate the chains every time bolt torque maintenance is performed.

### Carrier Beams

- Apply a graphite coating such as Slip Plate™ to the carrier beams as required to ensure a smooth push back operation.
- Follow application instructions as provided by the coating manufacturer.
- At the end of the season apply a coating to prevent rust on the carrier beams.

## MAINTENANCE

**⚠ CAUTION** Place all controls in neutral, stop engine, set parking brake, remove ignition key and wait for all moving parts to stop before servicing, adjusting or repairing the 2500 Bale Carrier.

**⚠ CAUTION** Ensure the 2500 Bale Carrier tires and hitch are securely block. Otherwise, verify the 2500 Bale Carrier is properly coupled to the drawbar on a tractor with a minimum mass of 25000 LB (11340 kg).

**NOTE:** Service intervals should be increased when operating in extreme or difficult conditions.

### 1. Fasteners

- Inspect all bolt torques after first use and 50 hours thereafter.
- Periodically inspect for broken or missing fasteners. Replace with fasteners of similar size and equivalent grade.
- The table below lists the correct torque values for various bolts and cap screws used on the bale carrier. Tighten all bolts to specified values unless otherwise noted.

BOLT DIAMETER "A"	BOLT TORQUE					
	SAE 2		SAE 5		SAE 8	
	lb-ft	N.m	lb-ft	N.m	lb-ft	N.m
1/4"	6	8	9	12	12	17
5/16"	10	13	19	25	27	36
3/8"	20	27	33	45	45	63
7/16"	30	41	53	72	75	100
1/2"	45	61	80	110	115	155
9/16"	70	95	115	155	165	220
5/8"	95	123	160	215	220	298
3/4"	155	225	290	390	400	540
7/8"	170	230	420	570	650	880
1"	225	305	630	850	970	1320
<b>LOCATION</b>					<b>lb-ft</b>	<b>N.m</b>
WHEEL HUB BOLTS					125	170
ALL CARRIAGE BOLTS					33	45

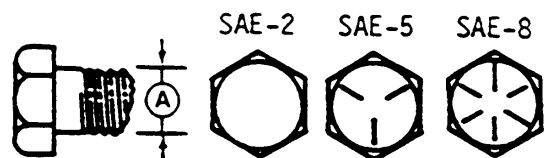

## 2. Hydraulic System

**⚠ WARNING** Escaping fluid under pressure can have sufficient force to penetrate the skin, causing serious personal injury. Before repairing, adjusting, or disconnecting lines, be sure to relieve all pressure.

**⚠ WARNING** Never operate the 2500 Bale Carrier with frayed or damaged hoses or leaking fittings. A burst would cause the lift arm to drop suddenly and result in serious injury or death and cause damage to the loader or tractor.

- Before applying pressure to the system, be sure all connections are tight and the lines, pipes, and hoses are not damaged.
- Wear proper hand and eye protection when searching for leaks. Use a piece of wood or cardboard instead of hand to check for leaks.
- Maintain all components in good working order.
- If injured by escaping fluid, see a doctor at once. Serious infection or toxic reaction can develop if proper medical treatment is not administered immediately.
- Regularly check the fluid level in the tractor reservoir and follow the maintenance procedures in the tractor Operator's Manual.
- Regularly inspect cylinders, hoses and fittings for leaks, crimps and abrasions or other signs of wear and tear or impending failure.
- Ensure hoses do not bind or stretch during operation. Always keep hoses tied or supported to prevent rubbing against sharp areas or being pinched. We suggest using tie wraps to support hoses.
- Replacement hoses must have a working pressure of 3000 psi (20685 kpa) or higher.

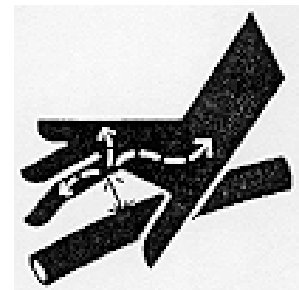
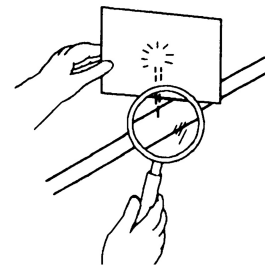

## 3. Hydraulic Fitting Torques

Dash Size	Thread Size	Jam Nut or Straight		SAE 37° (JIC)	
		ORB Fitting Torque		Swivel Nut Torque	
		(ft-lbs)	(NM)	(ft-lbs)	(NM)
-04	7/16-20	14-16	20-22	10-11	13-15
-05	1/2-20	18-20	24-27	13-15	18-20
-06	9/16-18	24-26	33-35	17-19	23-26
-08	3/4-16	50-60	68-78	34-38	47-52
-10	7/8-14	72-80	98-110	50-56	69-76
-12	1-1/16-12	125-135	170-183	70-78	96-106
-14	1-3/16-12	160-180	215-245	80-90	110-122
-16	1-5/16-12	200-220	270-300	94-104	127-141
-20	1-5/8-12	210-280	285-380	124-138	169-188
-24	1-7/8-12	270-360	370-490	156-173	212-235

#### 4. Chains

- Check for proper chain tension and sprocket alignment after first use and every 50 hours thereafter.
- Turn the front sprocket adjusting bolt clockwise until there is approximately 6" (15 cm) of upward slack in the chain at the center of the track. Clockwise increases tension and counter clockwise reduces tension.
- Proper chain tension may be verified by raising the chain by hand.
- See lubrication section for further maintenance instructions.

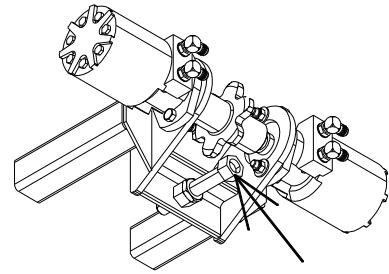

FRONT ADJUSTING  
BOLT

#### 5. Wheels / Tires

- Inspect hub bolts after first use and 50 hrs thereafter. Hub bolts must be torqued to 125 ft-lb (170 Nm).
- Thread-locking compound such as Loctite 242 is recommended for the hub bolts.
- Ensure that dust caps are firmly in place.
- Check tire pressure regularly: 90 psi (620 kpa).
- The wheel bearings should be inspected and re-packed annually with a SAE multi purpose type grease. If hub is supplied with grease fitting, grease every 500hrs.
- Air valve should face away from the hub.

## 6. Storage

---

**⚠ CAUTION** Place all controls in neutral, stop engine, set parking brake and remove ignition key before inspecting, servicing, adjusting or repairing the 2500 Bale Carrier.

---

**⚠ CAUTION** Ensure the 2500 Bale Carrier tires and hitch are securely block. Otherwise, verify the 2500 Bale Carrier is properly coupled to the drawbar on a tractor with a minimum of 25000 LB (11340 kg).

---

### Start of Season

- Clean and inspect the bale carrier when taking it out of storage. Ensuring that the bale carrier is in optimum condition at the start of the season reduces the chances of a costly breakdown during the season.
- Clean and inspect chains and chain rollers for excessive wear or stiffness. Check for proper adjustment and alignment.
- Lubricate entire bale carrier. Ensure that all grease fittings are in place and taking grease properly.
- Operate the bale carrier for a short time. Check that all moving parts are operating freely. Check for hydraulic leaks.
- Inspect and repack wheel bearings with a SAE multi purpose type grease.
- Replace and secure safety shields. Review safety regulations.
- Check all bolts for tightness. Replace lost or worn bolts.
- Check that tires are properly inflated.
- Review the Operator's Manual.

### During The Season

- At the end of each day of operation park the bale carrier in a clean, dry, sheltered area.
- Lubricate areas requiring daily lubrication.
- Remove any build up of hay or straw.

### End Of Season

- Replace worn or damaged parts and replace if necessary. To avoid costly delays contact your dealer for replacement parts before the start of the next season.
- Store the bale carrier in a clean, dry, sheltered area.
- Replace all missing or broken bolts with bolts of similar size and grade.
- Clean the baler carrier thoroughly. Dirt draws moisture that rusts metal.
- Repaint chipped or worn areas. Paint is available from your dealer.
- Clean chains and brush with SAE light machine oil (or equivalent) to prevent rust.
- Repaint the top of the carrier beams with a graphite paint such as Slip Plate™ to prevent rust.

**APPENDIX LIST**

<b>Description</b>	<b>Appendix</b>
Assembly Instructions.....	<b>A</b>
Hydraulic Assembly.....	<b>B</b>
Electrical Assembly.....	<b>C</b>
General Assembly.....	<b>D</b>

**APPENDIX A****Assembly Instructions****Table of Contents**

<b>Description</b>	<b>Page</b>
Taillight Assembly.....	23
Center Bale Stop.....	23
Fixed Lift Arm.....	23
Bale Deflector Arm Assembly.....	24
RPU Assembly.....	24



**⚠ CAUTION** Make sure area is clear of obstructions, well lit, and has sufficient room for safe assembly. Do not work underneath raised assembly.

**⚠ CAUTION** Ensure the carrier's tires and hitch are securely blocked. Otherwise, verify the 2500 Bale Carrier is properly coupled to the drawbar on a tractor with a minimum of 25000 LB (11340 kg).

### 1. Tail Light Assembly

Refer to carrier final assembly drawing in Appendix D.

- Remove all required hardware from parts box.
- Ensure taillights are installed correctly, refer to illustration.
- Connect the tail light wiring harnesses to their appropriate connections.
- Connect main lighting plug to tractor.
- Test by verifying correct lamps illuminate when signalling and braking.

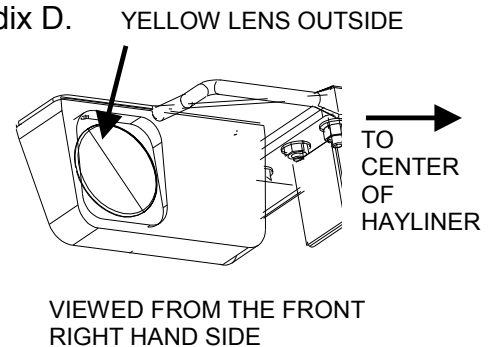

### 2. Centre Bale Stop

- Remove the hardware that is attached to the center bale stop and place center bale stop bar on bolt plates in the position shown at the beginning of the manual. Torque the provided hardware to the specifications listed on the bolt chart. Tie wrap the hydraulic hoses that run to the lift and tilt cylinders under the roll bar.

**NOTE:** Hydraulic Assembly methods and layouts are common to the right and left sides. Only one side of each component is shown in this manual.

**⚠ CAUTION** Stay clear of the arms when testing a finished assembly. Ensure during assembly to keep your entire body out from underneath parts that are being attached to the main frame.

### 3. Fixed Lift Arm

- Remove lift arm pivot pins that are installed on the 2500 Bale Carrier.
- Thoroughly lubricate all pins involved in the assembly with a SAE multi purpose grease.
- Align arm to pivots with open end of arm facing forward and reinstall pins with hardware provided and torque to specifications called for in the bolt chart.
- Remove the lift cylinder pin from the arm.

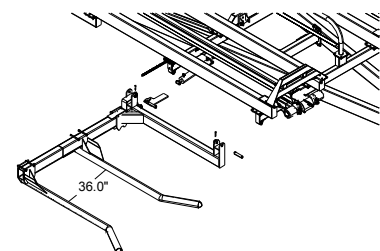

FIXED LIFT ARM ATTACHMENT

- Align the lift cylinder rod and reinstall the pin.
- Adjust the outside bale fork to be positioned at the end of the lift arm and the inner bale fork about 36" (91 cm) from the end.
- Recheck all hardware so that every bolted connection on the lift arm is torqued according to the specifications of the bolt chart.
- Approach the bale and inspect to ensure the spacing of the forks is accurate.
- For first operation, cycle the lift arm slowly with a bale and inspect just before lifting bale from ground.
- Finish the cycle and observe how the bale transits from the forks to the carrier beam. If transition is smooth with minimum bale binding, assembly is completed. If not, adjust the forks to a different location and try until loading is smooth.

### 4. Bale Deflector Arm Assembly

- Remove all hardware that is included with the deflector assembly.
- Remove the two top bolts from outer fork on lift arm.
- Maintain the spacing of the forks if already preset. If not, set spacing as described in the fixed pick up arm assembly section.
- Insert the coned end of the deflector onto the end of the outer fork.
- Align the bolt holes from the removed bolts on the outer fork and the end of the deflector attachment.
- Insert hardware supplied with the deflector the same way the hardware was installed before the attachment was added. Torque all hardware according to the bolt chart and tighten the set screws on the cone also according to the chart.
- During first bale lift, cycle slowly and watch for excessive flexing or movement of the deflector. If movement is detected, stop cycle and re-torque all hardware involved.

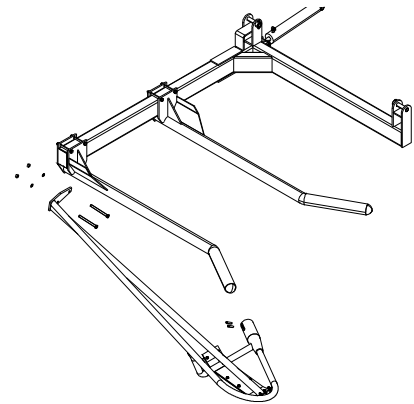

BALE DEFLECTOR ATTACHMENT  
ASSEMBLY LAYOUT

### 5. RPU Assembly

- Remove the lift cylinder pin from the RPU arm.
- Remove lift cylinder and install Pilot Check assembly (see Appendix B)
- Remove lift cylinder and install Pilot Check a assembly (see Appendix B)

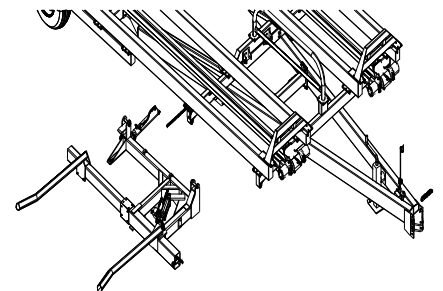

RPU ATTACHMENT  
ASSEMBLY LAYOUT

- Reinstall cylinder at base end only.
- Lubricate all pins involved in RPU attachment with a SAE multi purpose grease
- Align arm to pivots with open end of arm facing away from the 2500 Bale Carrier and reinstall pins with hardware provided and torque to specifications called for in the bolt chart.
- Align the lift cylinder rod and reinstall the pin.
- Adjust the outside bale fork to be positioned at the end of the lift arm and the inner bale fork 6" (15 cm) to 8" (20 cm) bigger than the size of bale that is being loaded.
- Install the hydraulics according to the way the hydraulic assembly Appendix B calls for.
- Recheck all hardware so that every bolted and hydraulic connection on the lift arm is torqued according to the specifications of the torque charts.
- Depress lift arm up. The RPU cycle should begin with a squeeze action, then lift and rotate. After rotation is complete the lift continues until the bale is above the carrier beams.
- Release LIFT ARM UP when bale is above the carrier beam. Depress LIFT ARM DN to release the bale and return to ground level ready for the next bale.
- For the first operation, cycle the lift arm slowly with the bale and observe the RPU operation.
- Approach the bale slowly; once the bale is captured in the forks press the lift switch. The bale is squeezed until the pressure in the sequence valve which is preset at 1800 PSI (12400 KPA) has been achieved.
- If bale is not held in between the forks increase the sequence valve pressure by turning the setscrew clockwise. Refer to the *RPU Rotate Cylinder* drawing for adjustment location of the setscrew. Verify that the fork spacing is accurate and refer to the drawing on this page for fork adjustments.
- The lift and rotate sequence won't begin until the clamp pressure is met within the sequence valve.
- When the clamp pressure is met, the lifting action should start before the rotating action to minimize bale damage from the moving ground.
- To increase lift prior to rotate turn the restrictor knob clockwise. Refer to the *RPU Rotate Cylinder* drawing for more information.
- Continue to raise the bale until it is positioned above the carrier beam.
- To release the bale, press lift arm down.
- Finish the cycle and observe how the bale transits from the forks to the carrier beam. If transition is smooth with minimum bale binding, assembly is completed. If not, adjust the forks to a different location and try until loading is smooth.

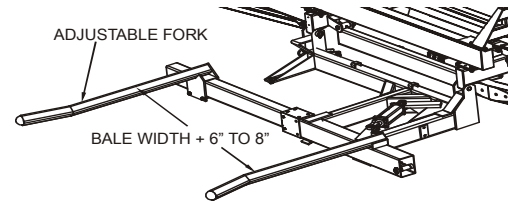

ROTATING PICK UP ARM

**APPENDIX B****Hydraulic Assembly**

---

**NOTE:** 1) Hydraulic Assembly methods and layouts are common to the right and left sides. Only one side of each component is shown in this manual.  
 2) Seal Kits and Service Parts are only listed in the parts lists and are not indicated on the illustrations.

---

**Table of Contents**

<b>Description</b>	<b>Page</b>
Carrier Hydraulic Assembly Schematic.....	27
Valve Bank Assembly.....	29
FPS Directional Valve Bank Assembly.....	31
Series Parallel Valve (Low and High Speed).....	32
Hydraulic Return Line Assembly.....	33
Hydraulic Pressure Line Assembly.....	34
Carrier Tilt Assembly.....	35
Fixed Pick Up Cylinder Assembly.....	36
Carrier Tilt Cylinders Hydraulic 3/8 line.....	37
Pusher Motor Assembly.....	38
Carrier Hydraulic Assembly Hardware.....	39
Fixed Pick Up Arm Hydraulic Assembly Schematic.....	40
RPU Hydraulic Assembly.....	41
RPU Squeeze Cylinder.....	42
RPU Lift Cylinder.....	43
Pilot Check Valve Assembly.....	44
RPU Rotate Cylinder.....	45
Open-Center Configuration Schematic.....	46
Open-Center Valve Assembly.....	47
2500 Bale Carrier Hydraulic Schematic.....	49

Carrier Hydraulic Assembly Schematic (Part # A7000-04) - Standard Configuration

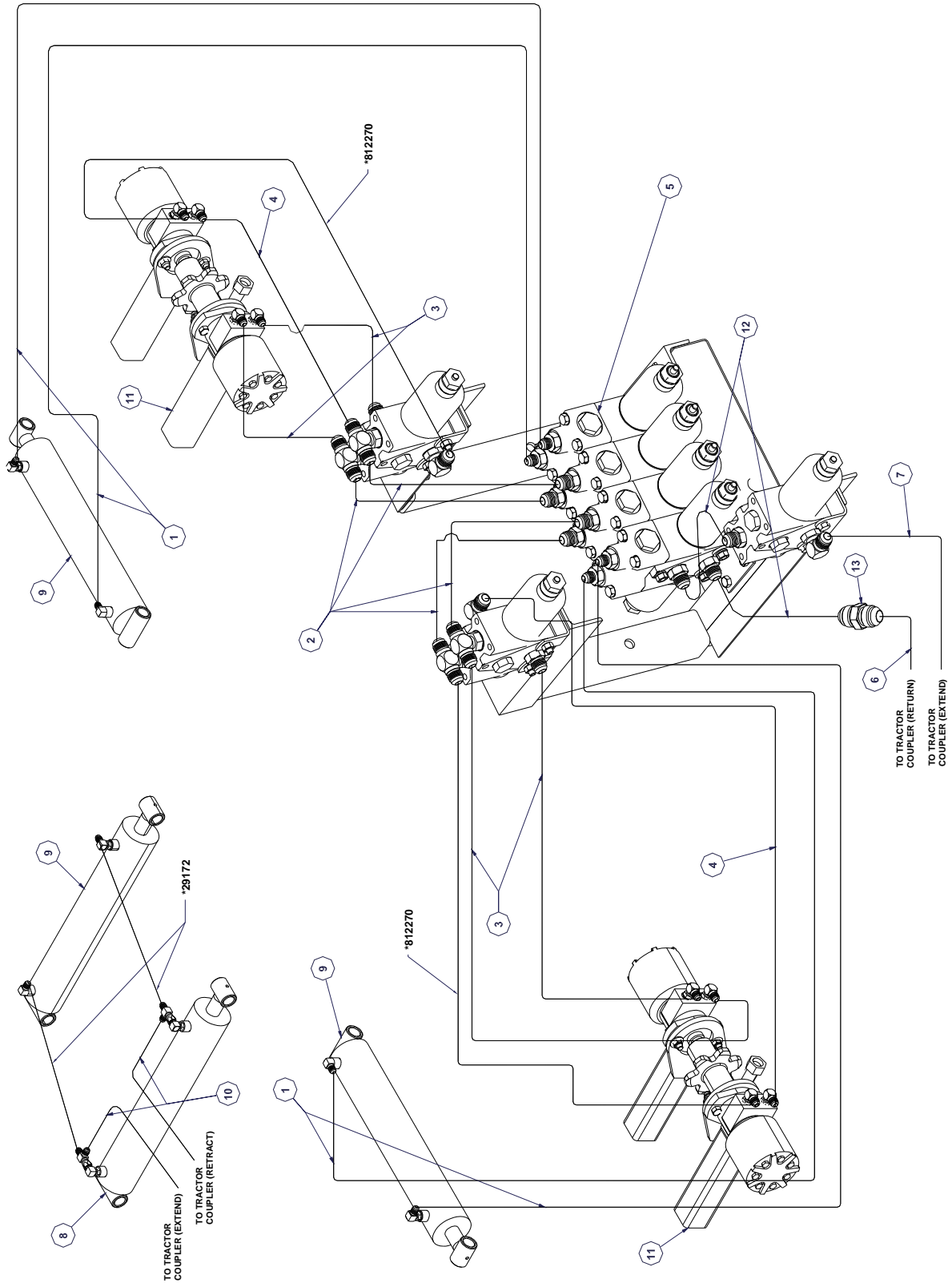

**Carrier Hydraulic Assembly (Part # A7000-04)  
Standard Configuration**

<b>Item</b>	<b>Component Part #</b>	<b>Description</b>	<b>Qty</b>
1	115169	HOSE 3/8 X 132 9/16 SWFJIC X SWFJIC	4
2	29108	HOSE 1/2 X 16 3/4 SWFJIC X SWFJIC	4
3	29110	HOSE 1/2 X 32 3/4 SWFJIC X SWFJIC	4
4	29176	HOSE 1/2 X 54 3/4 SWFJIC X SWFJIC	2
5	A7005-00	VALVE BANK ASSEMBLY	1
6	A7010-00	HYD ASSY 1/2 X 130 RETURN LINE	1
7	A7011-00	HYD ASSY 1/2 X 130 PRESSURE LINE	1
8	A7012-00	TILT ASSY 3.0 X 16.0 CYLINDER	1
9	A7013-00	TILT ASSY LIFT ARM CYLINDER	3
10	A7014-00	TILT ASSY CYLINDER 3/8 HYDRAULIC LINE	2
11	A7007-00	PUSHER MOTOR ASSEMBLY	2
12	29105	HOSE 1/2 X 28 3/4 SWFJIC	2
13	886704	ADAPTOR STR. 3/4 MJIC	1

**Note: All items marked with (\*) are not supplied on the main assembly.**

## Valve Bank Assembly (Part # A7005-00) Open-Center Configuration

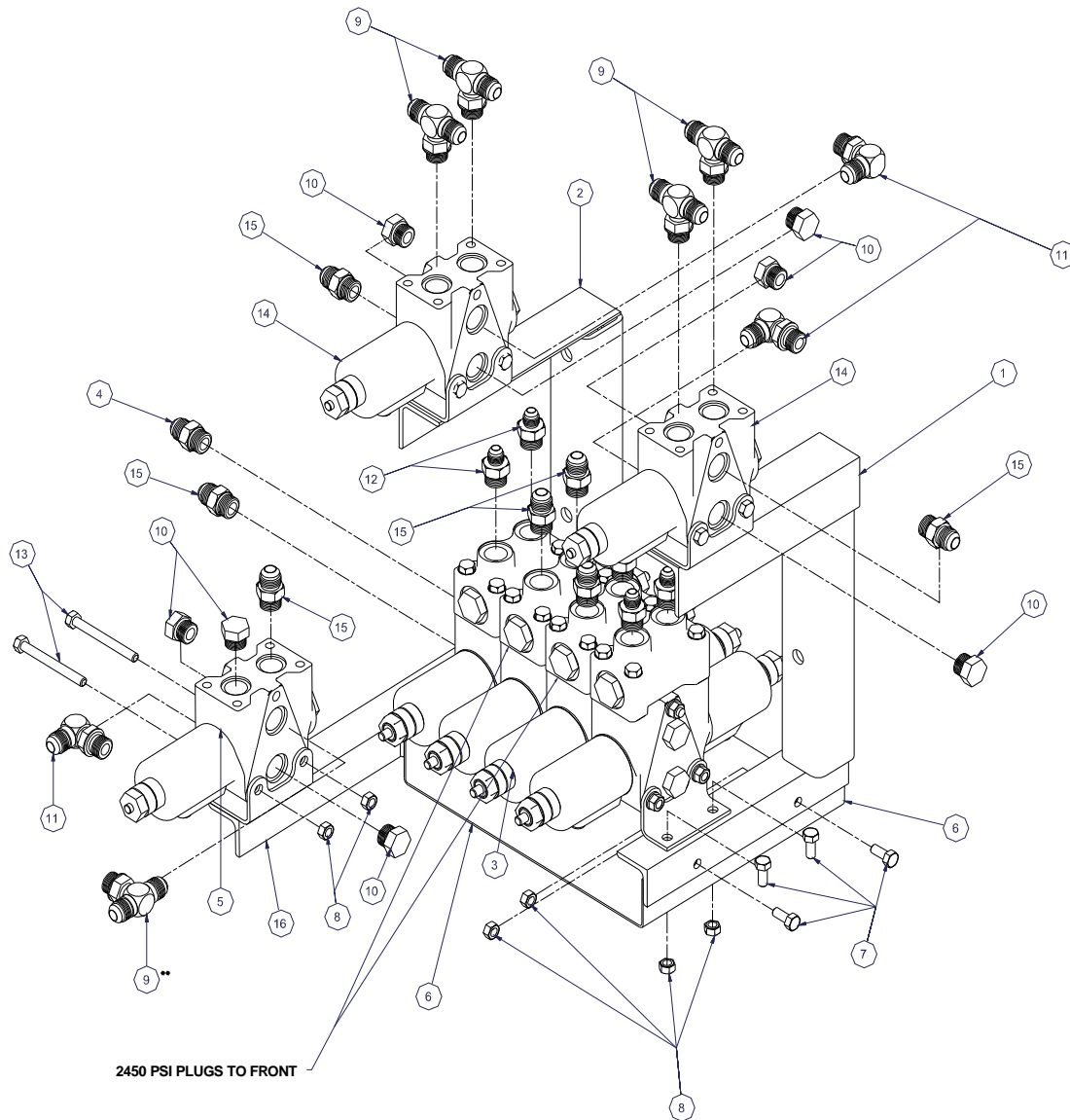

**(\*\*) To be used only with OPEN-CENTER configuration.**

**Valve Bank Assembly (Part # A7005-00)  
Open-Center Configuration**

Item	Component Part #	Description	Qty
1	C7041-00	VALVE BANK MOUNT WELDMENT LH	1
2	C7042-00	VALVE BANK MOUNT WELDMENT RH	1
3	B7009-00	FPS DIRECTIONAL VALVE ASSY (22214)	1
4	E2781-00	FLOW RESTRICTOR 0.25 DIA	1
5	A7016-00	OPEN-CENTER VALVE ASSY	1
6	E7050-00	PAN / VALVE BANK	1
7	81549	BOLT HEX 0.313NC X 0.75 GR5PL	8
8	812362	NUT LOCK (STEEL) 0.313NC GRBPL	15
9	813667	TEE RUN 1/2 MJIC X 3/4 MORB	5
10	812081	PLUG 3/4 MORB STL 721-FS0-08	7
11	811414	ELBOW 90 3/4 MORB X 3/4 MJIC	3
12	812107	ADAPTOR STR 3/4 MORB X 9/16 MJIC	4
13	810582	BOLT HEX 0.313NC X 3.00 GR5PL	6
14	B7010-00	SERIES/PARALLEL VALVE (2-SPEED)	2
15	812080	ADAPTOR STR 3/4 MORB X 3/4 MJIC	8
16	C7043-00	OPEN CENTER MOUNT WELD'T	1



**FPS Directional Valve (Part # B7009-00)**

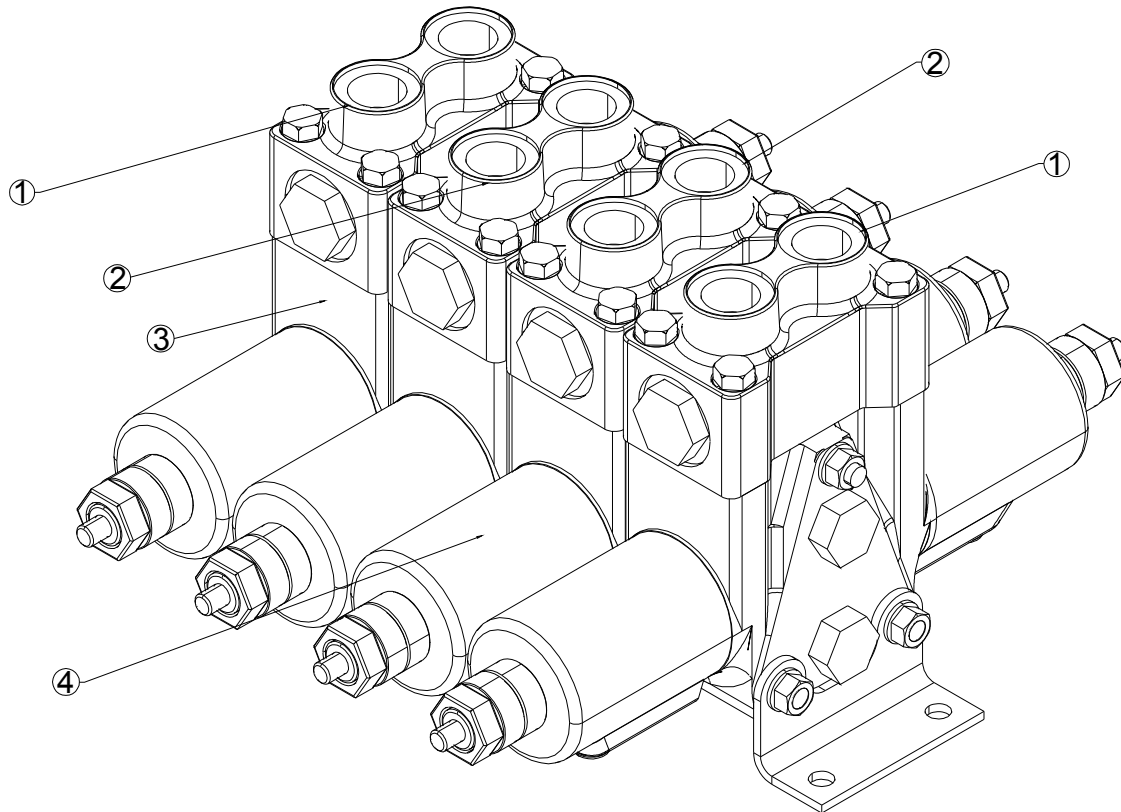

**B7009-00 FPS Valve Service Parts**

Item	Component Part #	Description	Qty
1	22208-02	MV4-17 LOCK VALVE	2
2	22149	CROSS OVER RELIEF VALVE BALE CARRIER SET @ 800 / 2450 PSI	2
3	22208-01	MVA-17 SPOOL SECTION	4
4	22208-04	C07-12TD COIL	8
5	X2684	SEAL KIT VALVE BANK (ITEM NOT VISIBLE)	4
6	813842	BOLT KIT VALVE (4) BANK	1

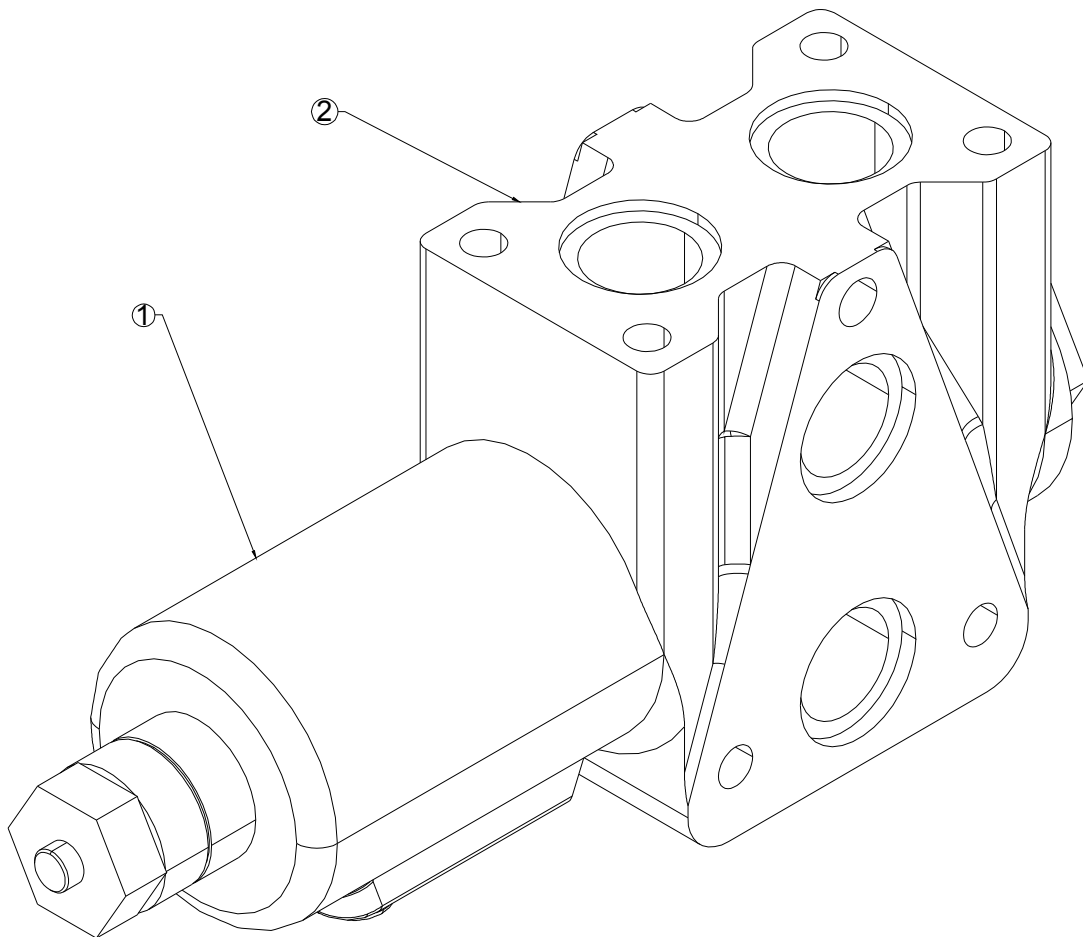
**Series/Parallel Valve Low and High Speed (Part # B7010-00)****B7010-00 Parallel Valve Service Parts**

Item	Component Part #	Description	Qty
1	22083-03	C07-12TD COIL	1
2	22083-01	SERIES PARALLEL VALVE (LOW & HIGH SPEED)	1
3	X2684	SEAL KIT VALVE BANK (ITEM NOT VISIBLE)	1

## Hydraulic Return Line Assembly (Part # A7010-00)

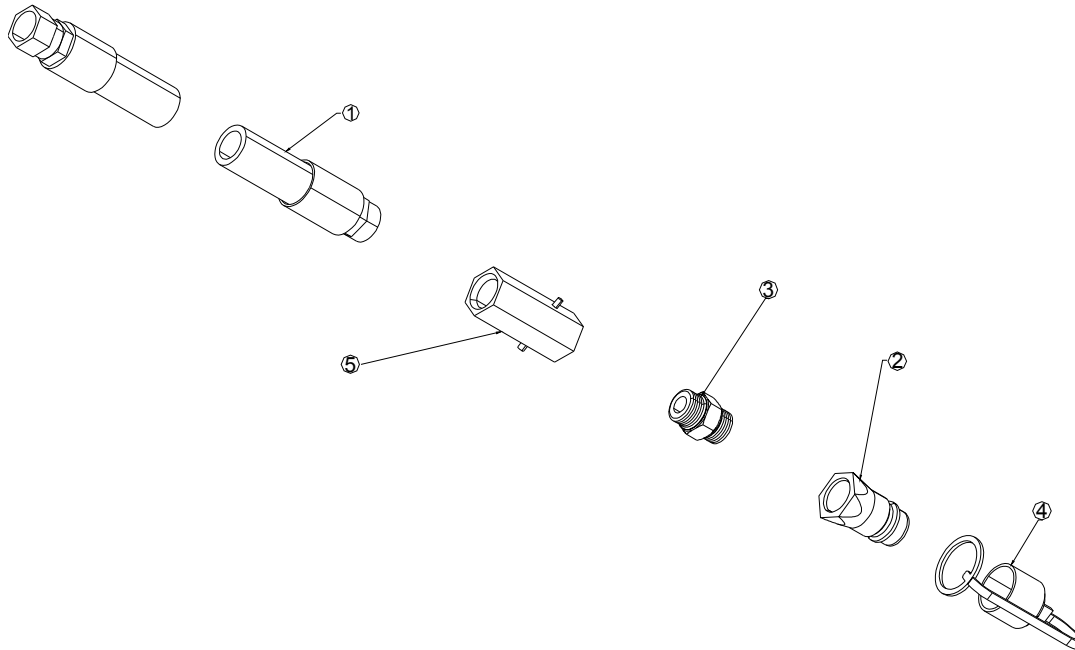

Item	Component Part #	Description	Qty
1	29170	HOSE 1/2 X 130 3/4 MORB X 3/4	1
2	812841	MALE TIP 0.5 BODY 0.75 ORB	1
3	813119	ADAPTOR STR 3/4 MORB X 3/4 MORB	1
4	813305	DUST CAP 0.5 BLACK	1
5	813666	VALVE CHECK 3/4 ORB LINE	1

## Hydraulic Pressure Line Assembly (Part # A7011-00)

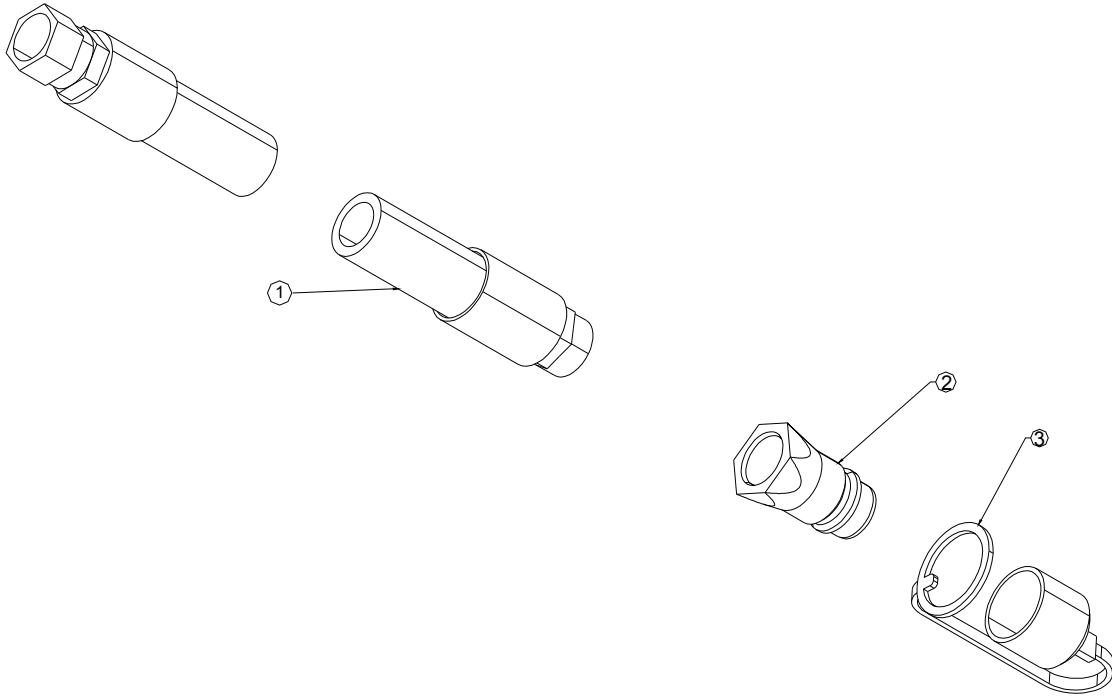

Item	Component Part #	Description	Qty
1	29170	HOSE 1/2 X 130 3/4 MORB X 3/4	1
2	812841	MALE TIP 0.5 BODY 0.75 ORB	1
3	813303	DUST CAP 0.5 RED	1

**Carrier Tilt Assembly (Part # A7012-00)**

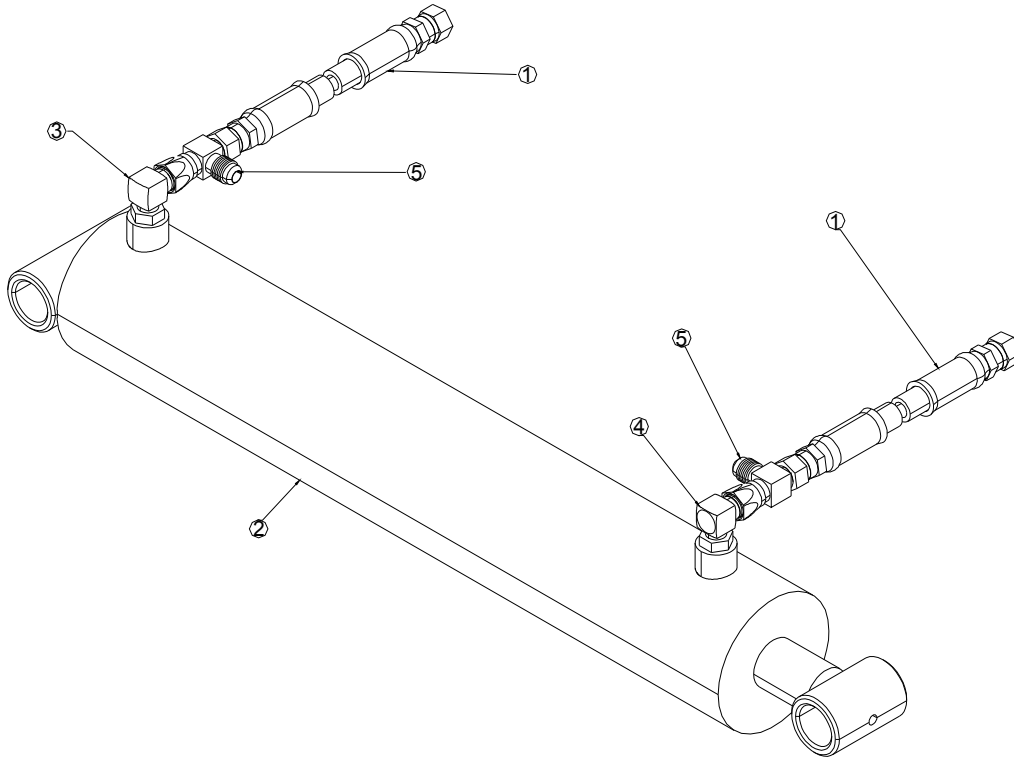

Item	Component Part #	Description	Qty
1	29172	HOSE 3/8 X 18 9/16 SWFJIC X SWFJIC	2
2	22510	CYLINDER 3.0 DIA X 16 INLAND	1
3	813640	ELBOW 90 9/16 MORB ADJ 9/16 MJIC	1
4	E2872-00	ELBOW RESTRICTOR MALE 90°	1
5	887572	TEE 9/16 MJIC X 9/16 SWFJIC	2

**22510 Cylinder 3.0 Diameter Service Parts**

Component Part #	Description	Qty
813407	LOCKNUT 1.00 NF	1
X2504	SEAL KIT FOR ITEM 22510	1
24957	TUBE WELDMENT 3.0 DIA	1
115519	SHAFT WELDMENT 1.50 X 22.63	1
24958	HEAD PLATE 3.0 X 1.50	1

**Fixed Pick Up Cylinder Assembly (Part # A7013-00)**

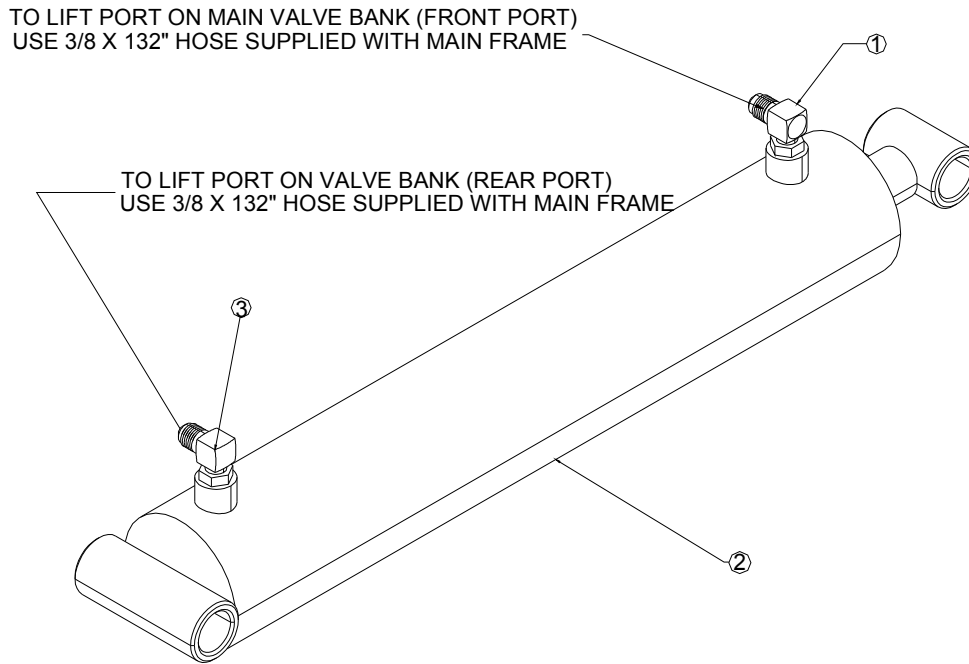

Item	Component Part #	Description	Qty
1	813640	ELBOW 90 9/16 MORB ADJ X 9/16 MJIC	1
2	22510	CYLINDER 3.0 DIA X 16 INLAND	1
3	E2872-00	RESTRICTOR ELBOW MALE 90	1

**22510 Cylinder 3.0 Diameter Service Parts**

Component Part #	Description	Qty
813407	LOCKNUT 1.00 NF	1
X2504	SEAL KIT FOR ITEM 22510	1
24957	TUBE WELDMENT 3.0 DIA	1
115519	SHAFT WELDMENT 1.50 X 22.63	1
24958	HEAD PLATE 3.0 X 1.50	1

## Carrier Tilt Cylinders Hydraulic 3/8 Line (Part # A7014-00)

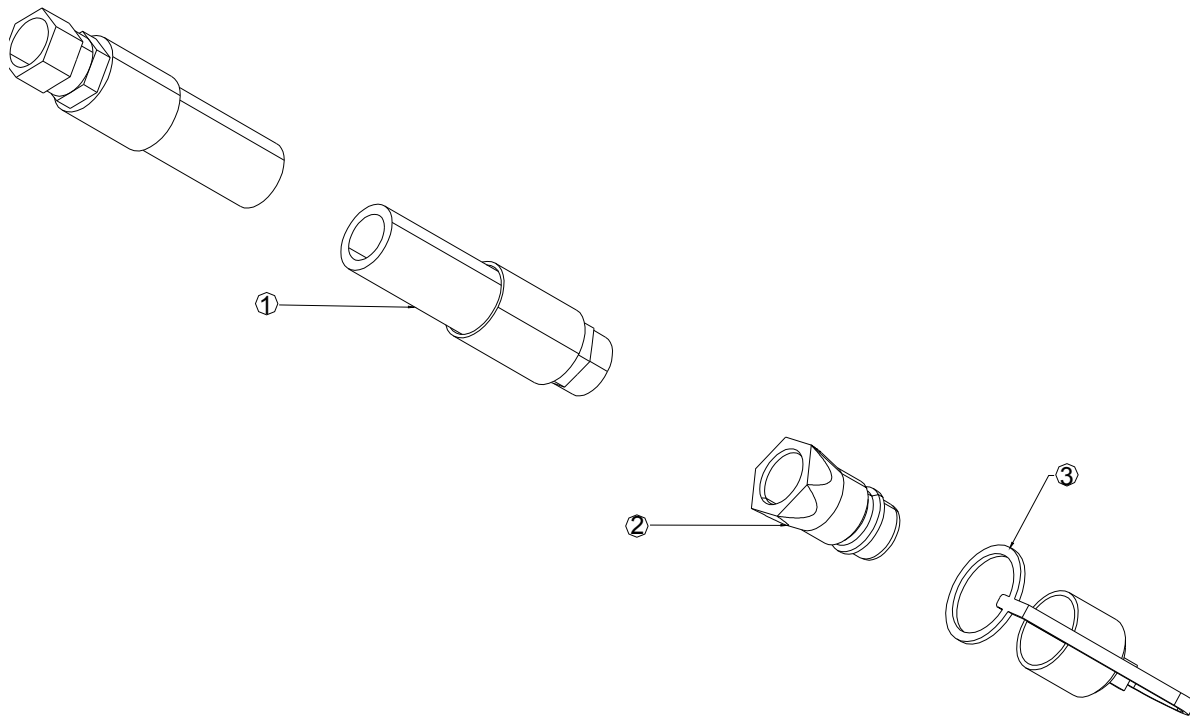

Item	Component Part #	Description	Qty
1	29173	HOSE 3/8 X 216 9/16 SWFJIC X 3/4 MORB	1
2	812841	MALE TIP 0.5 BODY 0.75 ORB	1
3	813303	DUST CAP 0.5 RED	1

**Pusher Motor Assembly (Part # A7007-00)**

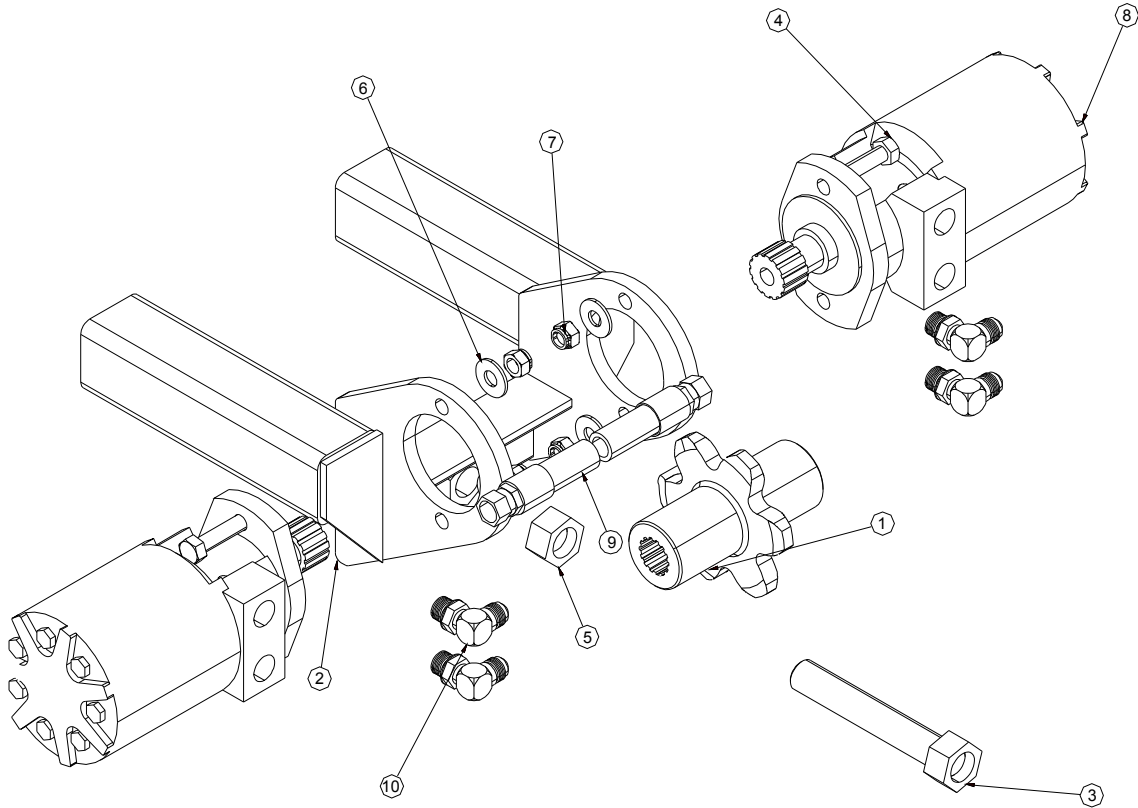

Item	Component Part #	Description	Qty
1	C7031-00	SPROCKET DRIVE WELDMENT	1
2	C7030-00	MOTOR 22.2 CU MT WELD	1
3	C2768-00	SPROCKET ADJUSTING BOLT FRONT 1NC	1
4	967275	BOLT HEX 0.500 NC X 2.00 GR8PL	4
5	84051	NUT HEX JAM 1.00 NC GR2	1
6	84048	WASHER 0.500 FLAT SAE BS PL	4
7	813663	NUT LOCK (STEEL) 0.500 NC GRCPL	4
8	B2799-00	MOTOR 22.2 CU PAINT YELLOW	2
9	812270	HOSE 1/2 X 48 3/4 SWFJIC X 3/4 SWFJIC	1
10	811416	ELBOW 90 7/8 MORB X 3/4 MJIC	4

**B2799-00 Motor Service Parts**

Component Part #	Description	Qty
X2725	SEAL KIT FOR B2799-00	1



## Carrier Hydraulic Assembly Hardware (Part # A7000-04)

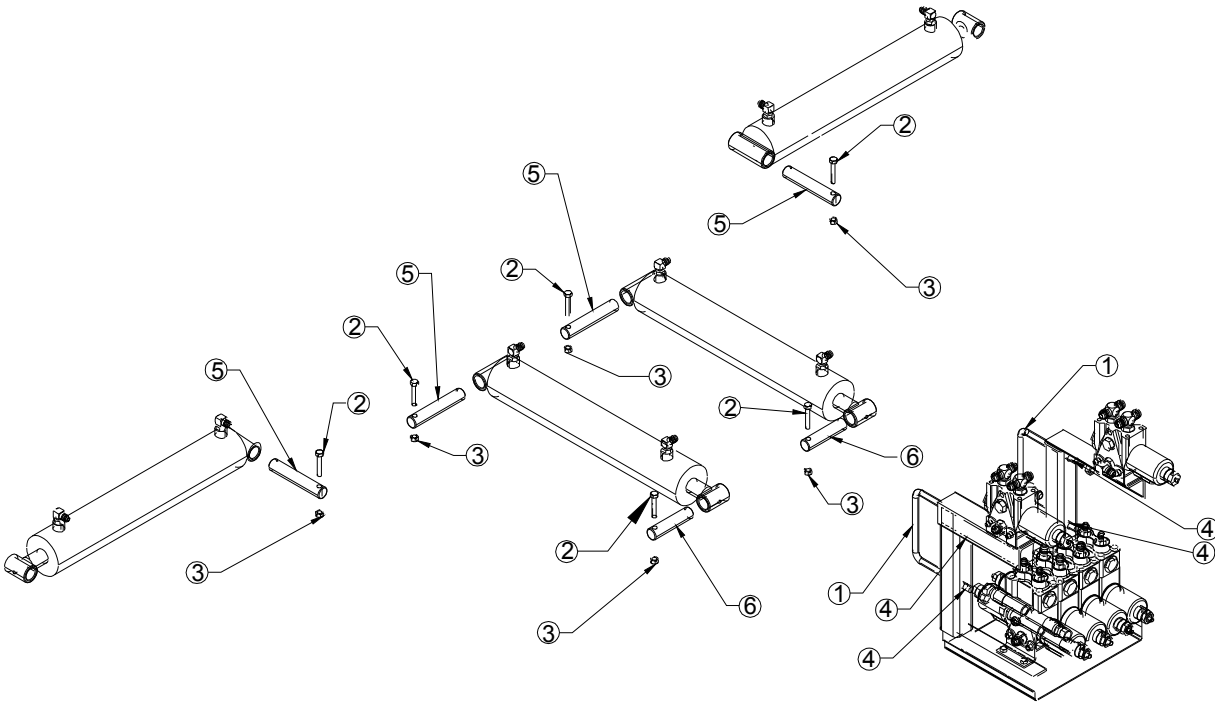

Item	Component Part #	Description	Qty
1	E7049-00	VALVE MT / U BOLT BALE CARRIER 0.5 NC	2
2	811795	BOLT HEX 0.375 NC X 2.00 GR5PL	6
3	812363	NUT LOCK (STEEL) 0.375 NC GRBPL	6
4	812364	NUT LOCK (STEEL) 0.500 NC GRBPL	4
5	E1932-00	CYL PIN 1 DIA X 5 9/16 C1045	4
6	E2345-00	CYL PIN 1 DIA X 4.5	2

**Note:** Open-Center Valve is not shown.

Fixed Pick Up Arm Hydraulic Assembly Schematic (Part # A2300-86)

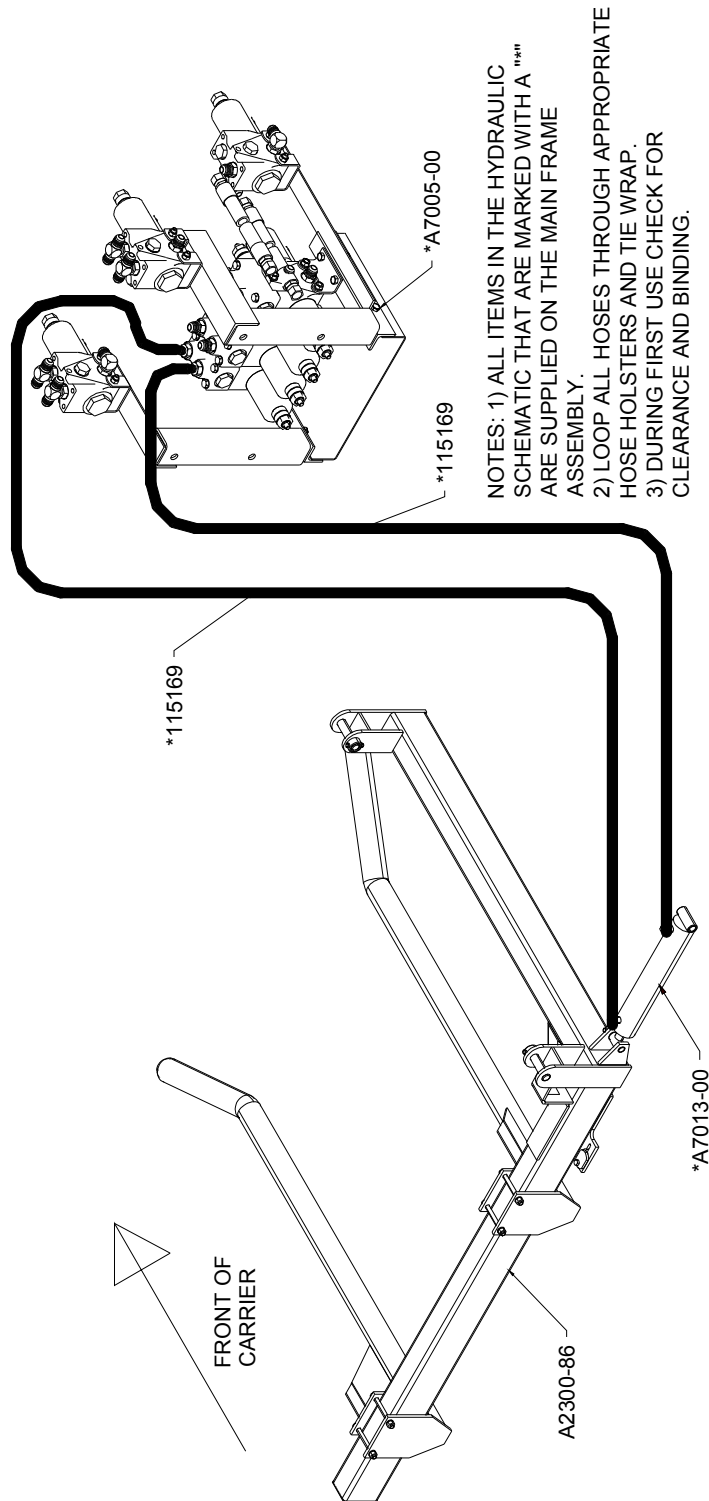

Hydraulic RPU Assembly Schematic (Part # A2400-34) (Optional)

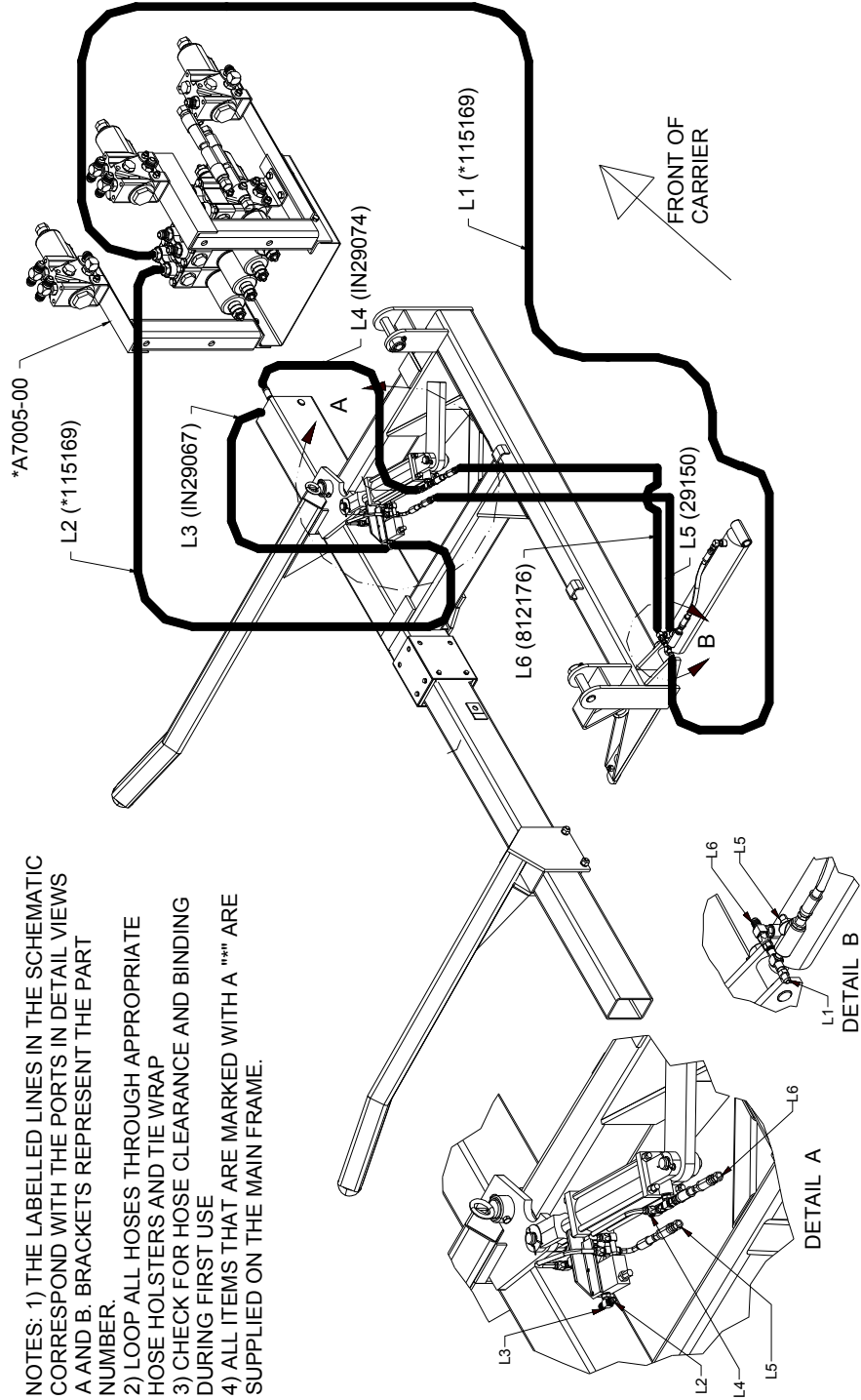

- NOTES: 1) THE LABELLED LINES IN THE SCHEMATIC CORRESPOND WITH THE PORTS IN DETAIL VIEWS A AND B. BRACKETS REPRESENT THE PART NUMBER.
- 2) LOOP ALL HOSES THROUGH APPROPRIATE HOSE HOLSTERS AND TIE WRAP
- 3) CHECK FOR HOSE CLEARANCE AND BINDING DURING FIRST USE
- 4) ALL ITEMS THAT ARE MARKED WITH A "\*" ARE SUPPLIED ON THE MAIN FRAME.

RPU Squeeze Cylinder (Part # A2400-35)

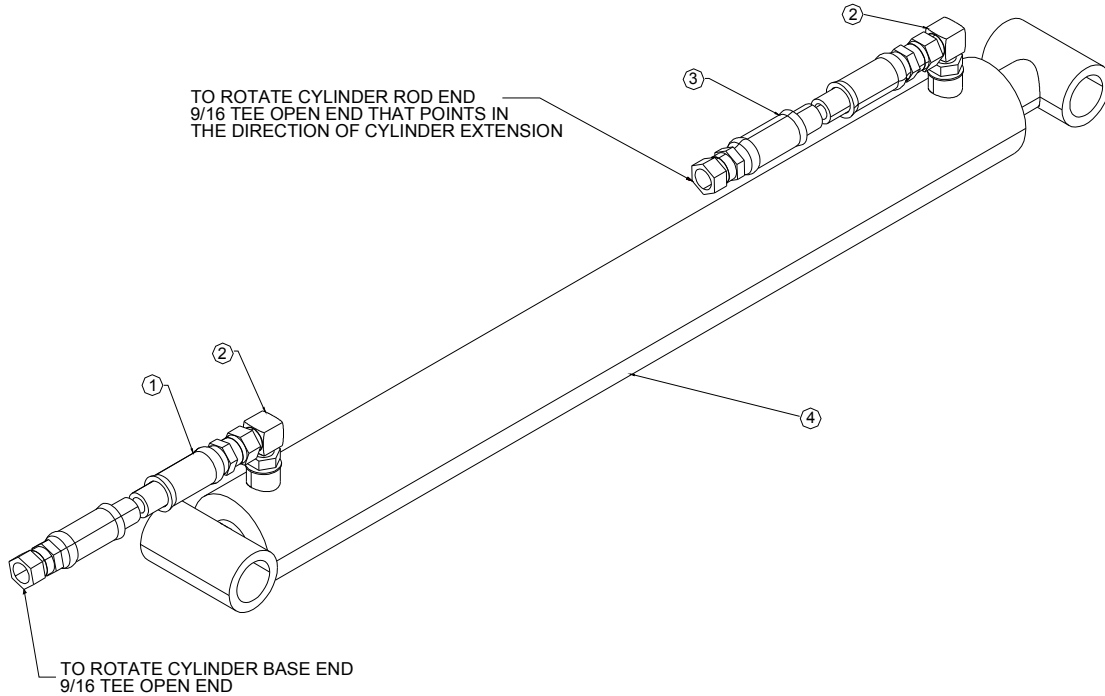

Item	Component Part #	Description	Qty
1	IN29074	HOSE 3/8 X 60 9/16 SWFJIC	1
2	813640	ELBOW 90° 9/16 MORB ADJ X 3/8	2
3	IN29067	HOSE 3/8 X 68 9/16 SWFJIC	1
4	24367	CYLINDER 2.0 X 18.0 INLAND	1

24367 Cylinder 2.0 Diameter Service Parts

Component Part #	Description	Qty
811843	NOT GREASE NIPPLE 90 DEGREES	1
X1348	SEAL KIT FOR 24367 2.0 DIA CYLINDER	1
83224	BACKUP WASHER 1.75 ID X 2.00 OD	1
812655	0.875 UNF LOCKNUT	1
144521	2.00 DIA PISTON HALF (NARROW)	1
114520	2.00 DIA PISTON HALF (WIDE)	1
24366	2.00 DIA TUBE WELDMENT	1
115042	SHAFT WELDMENT 1.25 DIA X 24.125 LG	1
24516	2.00 DIA HEAD PLATE	1

## RPU Lift Cylinder (Part # A2400-37 Assembled To Existing 22510 Cylinder)

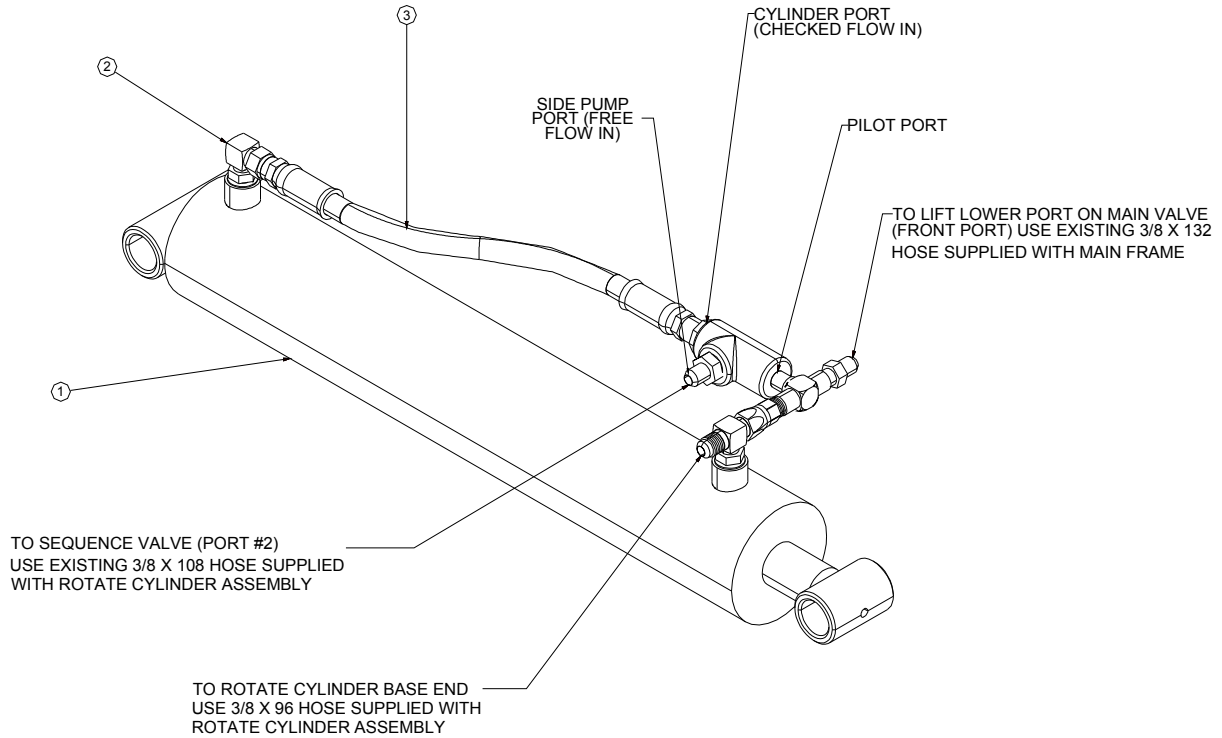

Item	Component Part #	Description	Qty
1	22510	CYLINDER 3.0 DIA X 16 INLAND	1
2	E2872-00	RESTRICTOR ELBOW MALE 90°	1
3	A2400-37	PILOT CHECK VALVE ASSEMBLY	1

### 22510 Cylinder 3.0 Diameter Service Parts

Component Part #	Description	Qty
813407	LOCKNUT 1.00 NF	1
X2504	SEAL KIT FOR ITEM 22510	1
24957	TUBE WELDMENT 3.0 DIA	1
115519	SHAFT WELDMENT 1.50 X 22.63	1
24598	HEAD PLATE 3.0 X 1.50	1

## Pilot Check Valve Assembly (Part # A2400-37)

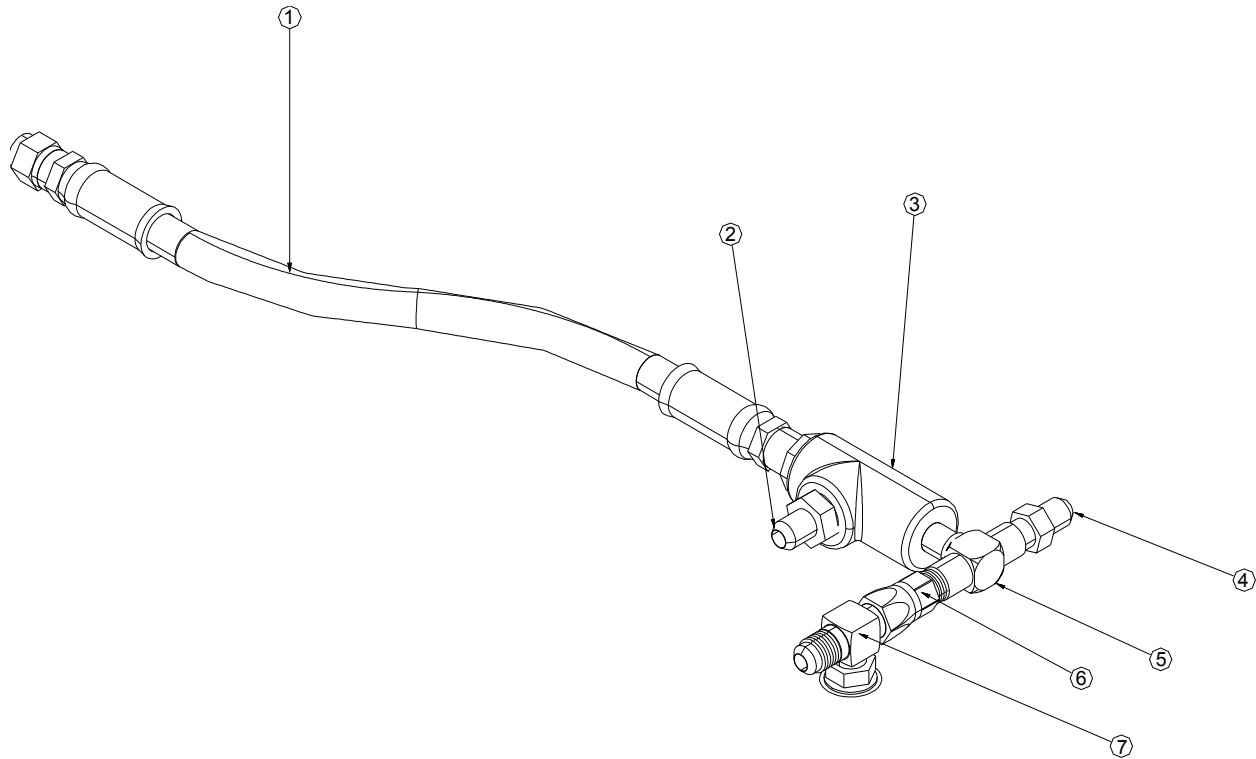

Item	Component Part #	Description	Qty
1	IN29098	HOSE 3/8 X 14 3/8 FNPT X 9/16 SWFJIC	1
2	29043	ADAPTOR STR 9/16 MJIC X 3/8 MNPT	1
3	22203	PILOT CHECK VALVE PC-37	1
4	29020	CONNECTOR 9/16 MJIC X 1/4 MNPT	1
5	29023	TEE 1/4 FNPT RUN X 1/4 MNPT	1
6	29039	ADAPTOR STR 1/4 MNPT X 9/16 FJIC	1
7	29015	TEE 9/16 MJIC RUN X 9/16 MORB	1

## RPU Rotate Cylinder (Part # A2400-36)

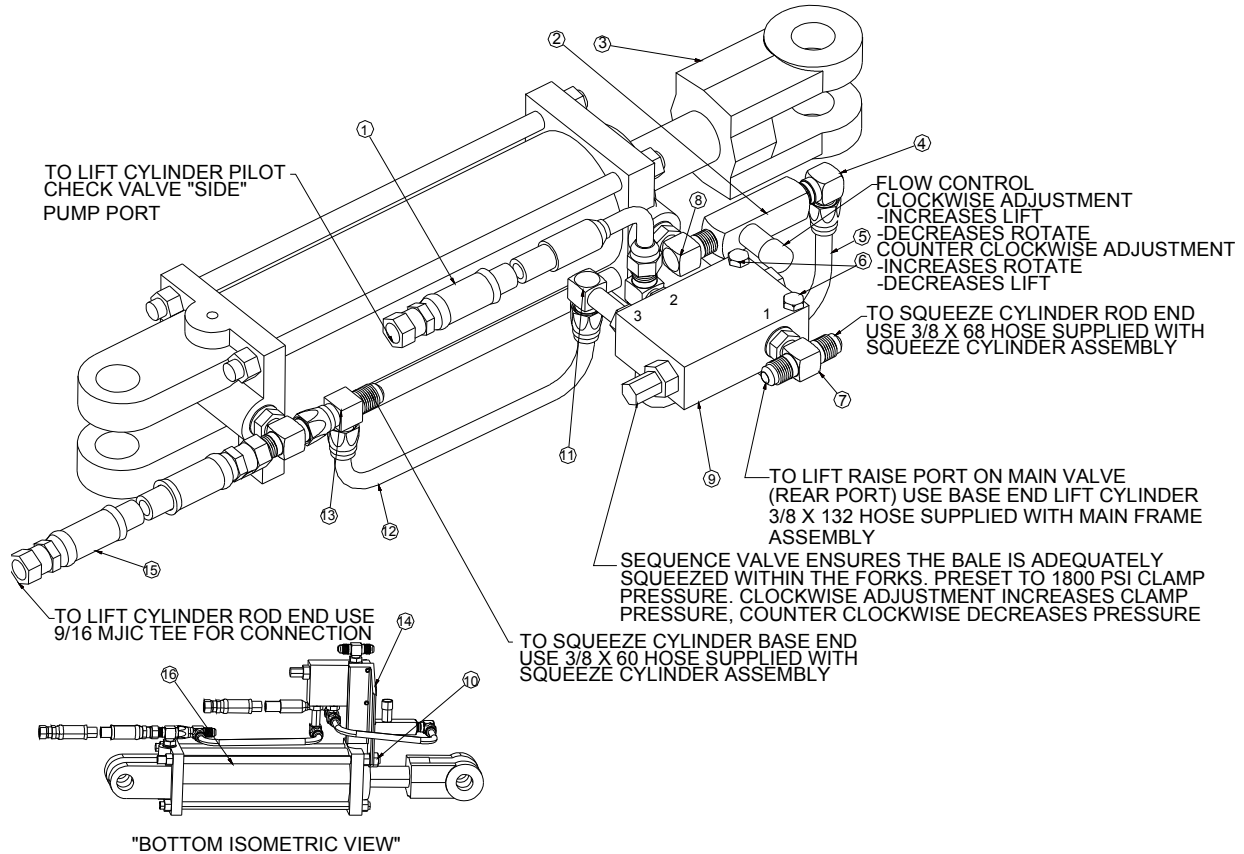

Item	Component Part #	Description	Qty
1	29150	HOSE 3/8 X 108 9/16 SWFJIC X 3	1
2	29149	RESTRICTOR ONE WAY ADJ PARKER	1
3	22060	3 X 8 TIE ROD CYLINDER	1
4	29016	ELBOW 90 1/4 MNPT X 9/16 MJIC	1
5	20877	PRESSURE LINE / SEQUENCE TUBE	1
6	811631	BOLT HEX JAM 0.500 NC GR2PL	2
7	29015	TEE 9/16 MJIC RUN X 9/16 MJIC	3
8	29022	ELBOW 90 1/4 MNPT X 9/16 MORB	1
9	22075	SUN SEQUENCE VALVE SET 1800 psi	1
10	984077	NUT HEX JAM 0.500 NC GR2PL	1
11	29047	ELBOW 90 9/16 MORB X 3/8 MJIC LG	1
12	813691	SEQUENCE VALVE VENT TUBE	1
13	887572	TEE 9/16 MJIC X 9/16 SWFJIC	1
14	E2430-00	SEQUENCE VALVE HOLDER	1
15	812176	HOSE 3/8 X 96 9/16 SWFJIC X 3	1
16	E2478-00	HYDRAULIC CYLINDER TIE ROD	1

## 22060 Cylinder 3.0 Diameter Service Parts

Component Part #	Description	Qty
22060-02	SEAL KIT FOR 22060 CYLINDER	1

Open-Center Configuration Schematic

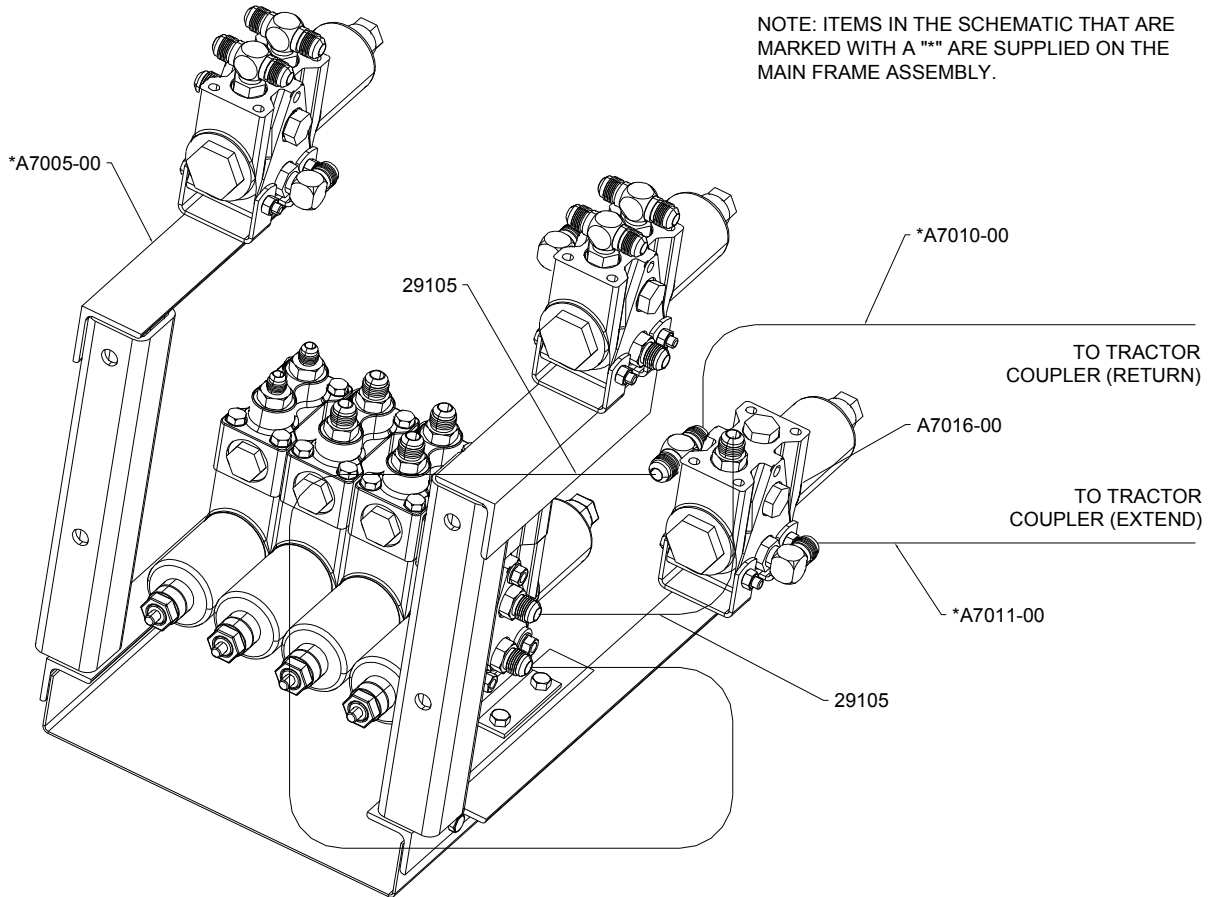



Open-Center Valve (Part # A7016-00)  
Open-Center Configuration

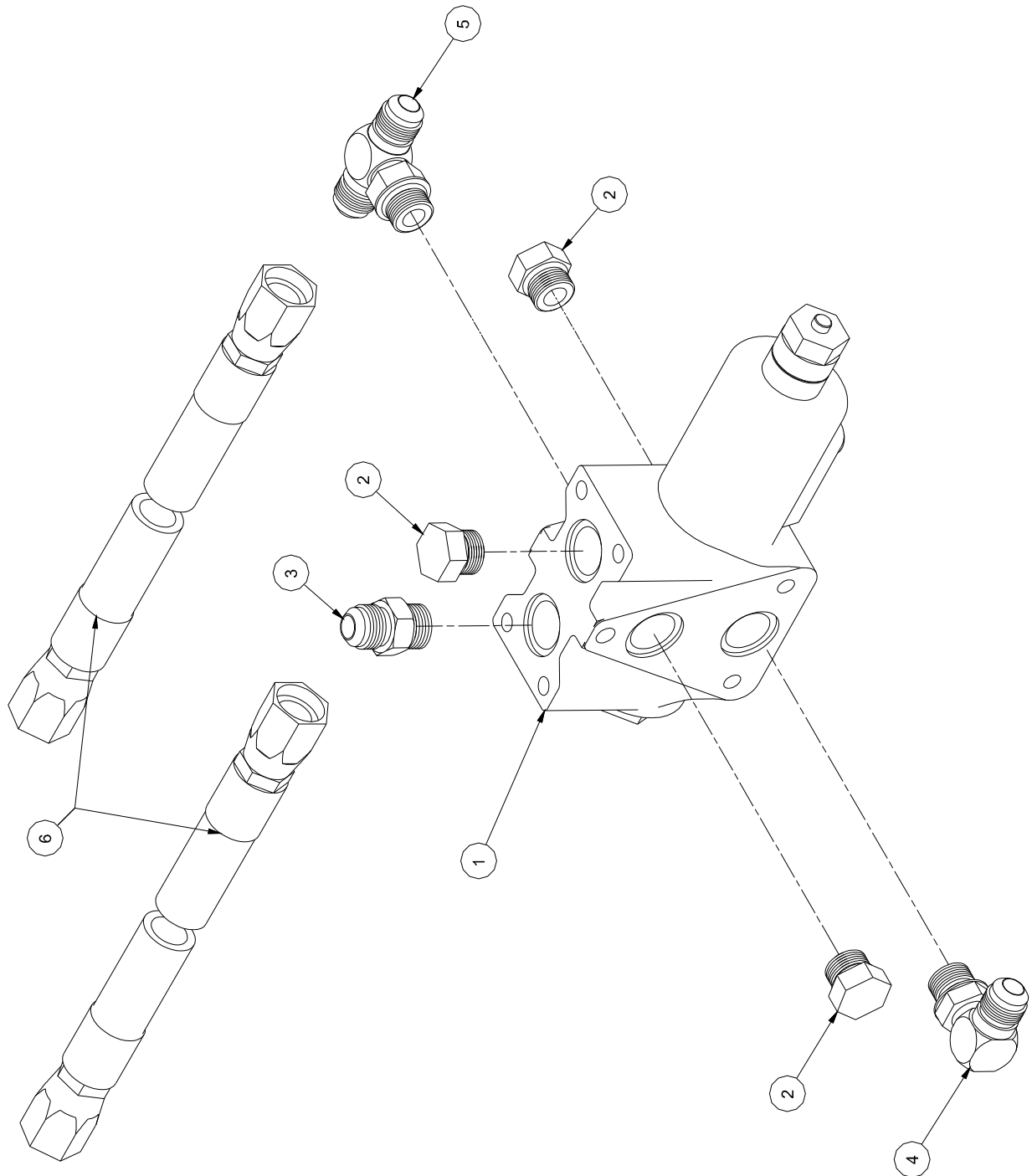

**Open-Center Valve (Part # A7016-00)  
Open-Center Configuration**

Item	Component Part #	Description	Qty
1	B7010	SERIES/PARALLEL VALVE	1
2	812081	PLUG 3/4 MORB STL 721-FS0-08	3
3	812080	ADAPTOR STR 3/4 MORB X 3/4 MJIC	1
4	811414	ELBOW 90 3/4 MORB X 3/4 MJIC	1
5	813667	TEE RUN 3/4 MJIC X 3/4 MORB	1
6	29105	HOSE 1/2 X 28 - 3/4 SWFJIC	2

**B7010-00 Parallel Valve Service Parts**

Component Part #	Description	Qty
22083-03	C07-12TD COIL	1
22083-01	SERIES/PARALLEL VALVE (LOW & HIGH SPEED)	1
X2684	SEAL KIT VALVE BANK	1

### 2500 Bale Carrier Hydraulic Schematic

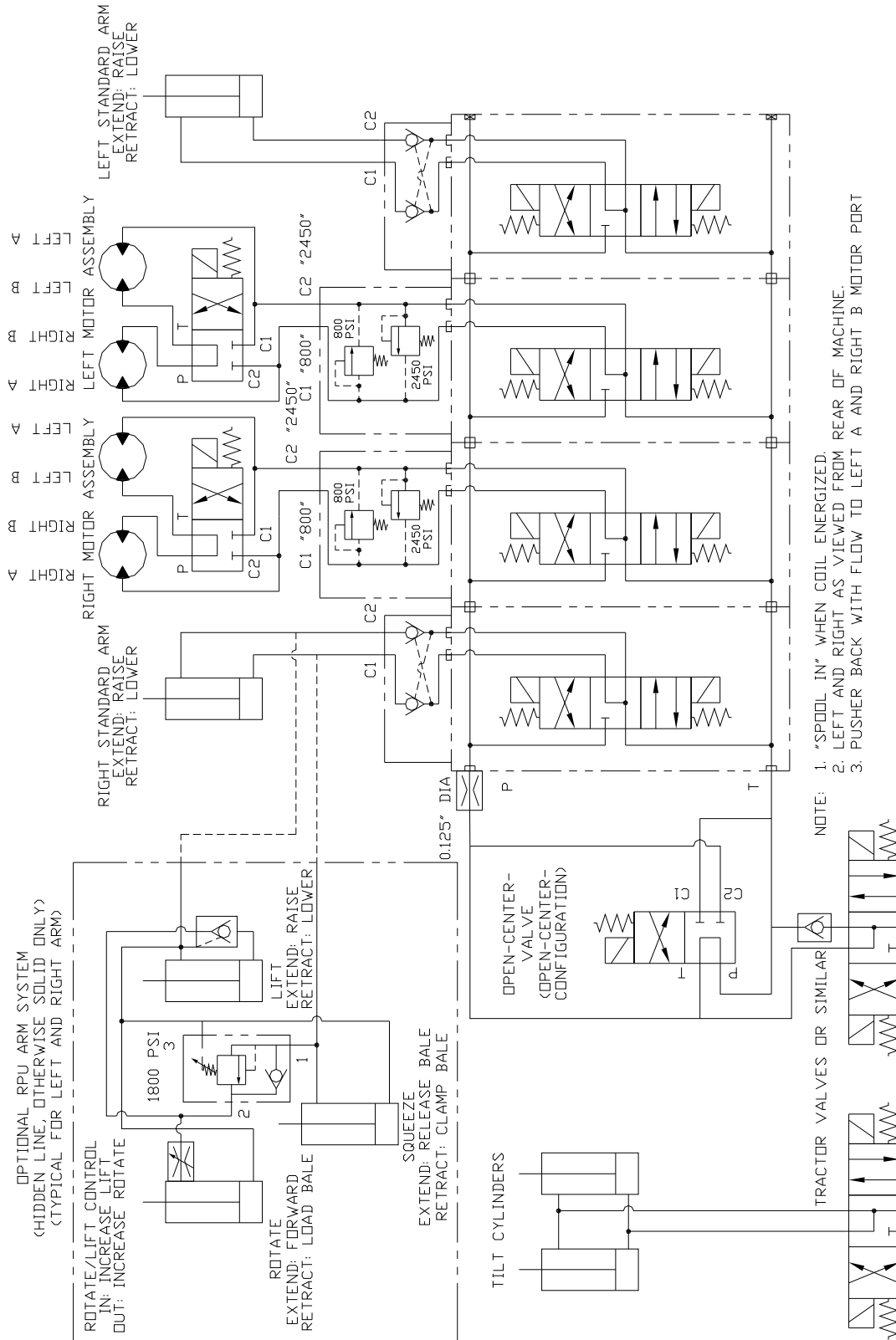



**APPENDIX C****Electrical Assembly**

---

**⚠ WARNING** Read and understand the safety messages listed in the 2500 Bale Carrier operator manual. Shut off all power to unit before inspecting, servicing, adjusting or repairing the 2500 Bale Carrier.

---

**⚠ WARNING** For proper operation of the Snubber, power must be supplied to the RED power wire from the control handle. Ensure that there is a 15 amp fuse in place to protect this circuit. Verify prior to installing Snubber. Incorrect wiring will result in electrical failure.

---

**NOTE:** The snubber unit is designed to protect the momentary control switches. The snubber minimizes coil voltage discharge during the de-energizing of the valve solenoid coils. There are no serviceable parts within the unit. Ensure that all electrical connections are clean and dry. Test the 2500 Bale Carrier and view to see if the hydraulic system is operating correctly. If any wires are damaged or cut, the schematic on the next page will assist in repair and maintenance. All wire is 18 gage.

---

**Table of Contents**

<b>Description</b>	<b>Page</b>
Electrical Schematic.....	52
Electrical Assembly .....	53

### Electrical Schematic

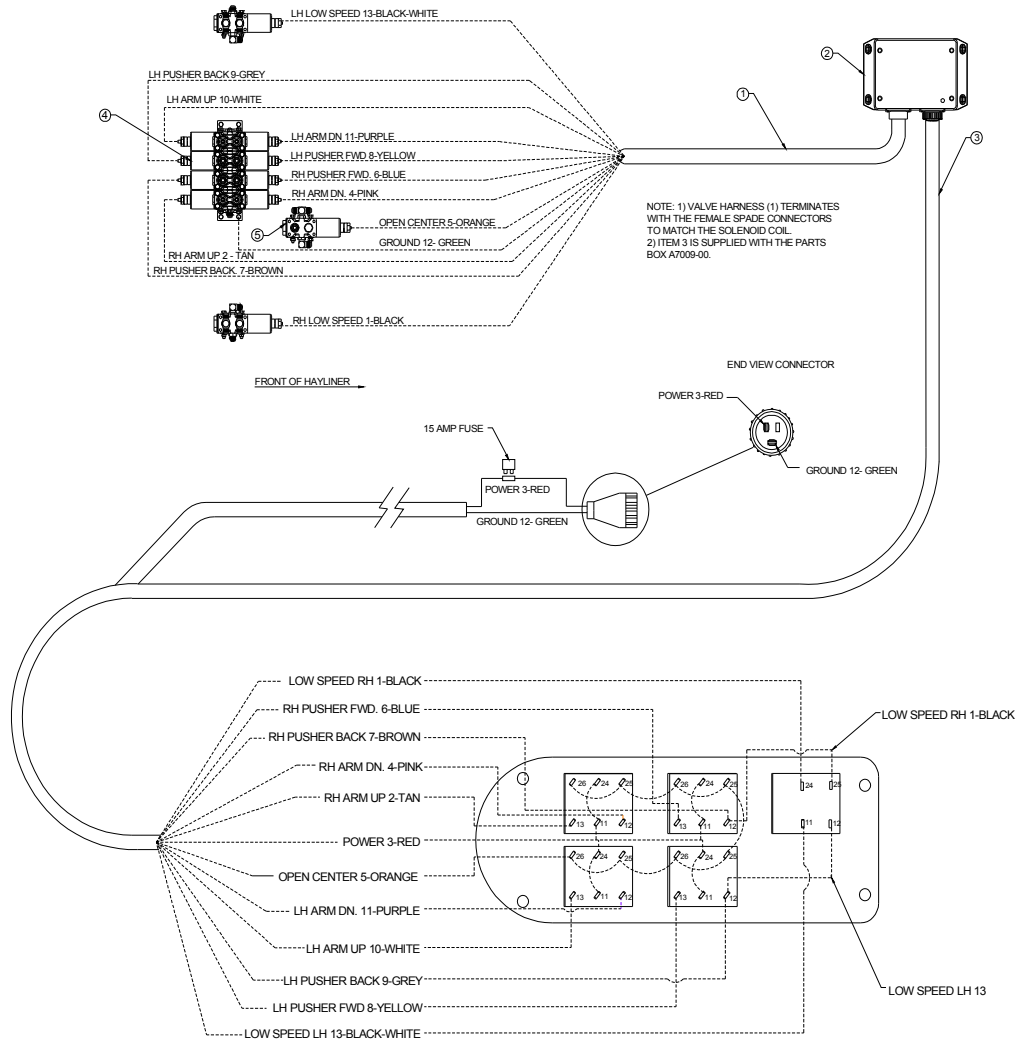

Item	Component Part #	Description	Qty
1	A7022-02	MACHINE HARNESS 2500 BALE CARRIER	1
2	813949	SNUBBER UNIT	1
3	A7022-00	CONTROL HANDLE HARNESS ASSEMBLY	1
4	A7005-00	VALVE BANK ASSEMBLY	1
5	A7016-00	OPTIONAL OPEN CENTER KIT	1

## Control Handle Assembly (Part # I20055)

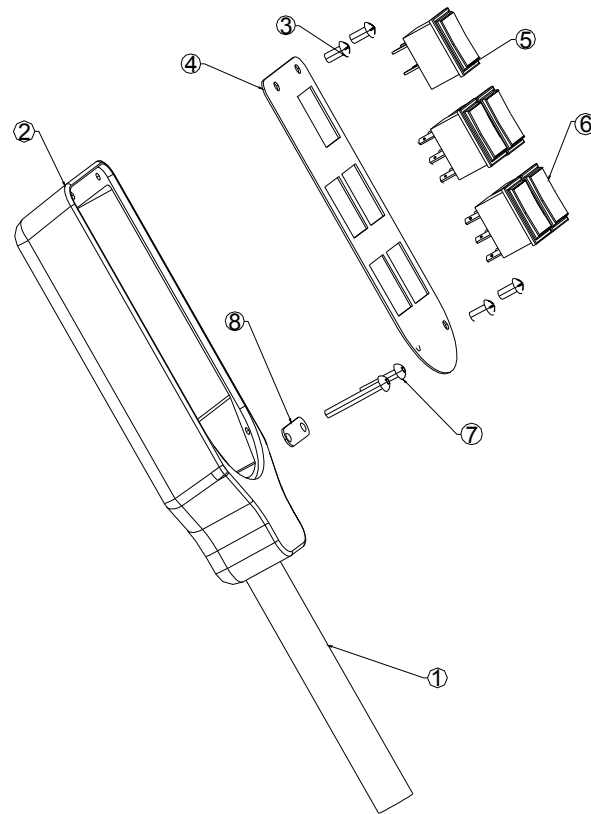

Item	Component Part #	Description	Qty
1	A7022-01	CONTROL HANDLE WIRES 2500 BALE CARRIER	1
2	22105	CONTROL HANDLE	1
3	813539	8-32 X 3/8 TRUSS HEAD MACHINE SCREW	4
4	INE22106	SWITCH COVER PLATE	1
5	813779	ROCKER SWITCH ON / OFF	1
6	814445	ROCKER SWITCH ON / OFF MOMENTARY	4
7	813540	8-32 X 1/2 ROUND HEAD MACHINE SCREW	2
8	INE22105-01	WIRE CLAMP PLATE	1





**APPENDIX D****General Assembly****Table of Contents**

<b>Description</b>	<b>Page</b>
Carrier Final Assembly.....	56
Carrier Initial Assembly.....	58
Tandem Axle Assembly.....	60
Tire Assembly.....	61
Tandem Axle Assembly.....	62
Hub Assembly.....	63
Pusher Assembly.....	64
Roller / Chain Guide Assembly.....	65
Fixed Pick Up Arm Assembly.....	66
RPU Assembly.....	70
Bale Deflector Assembly.....	74
Slow Moving Vehicle Sign Assembly.....	78

Carrier Final Assembly (Part # A7000-04)

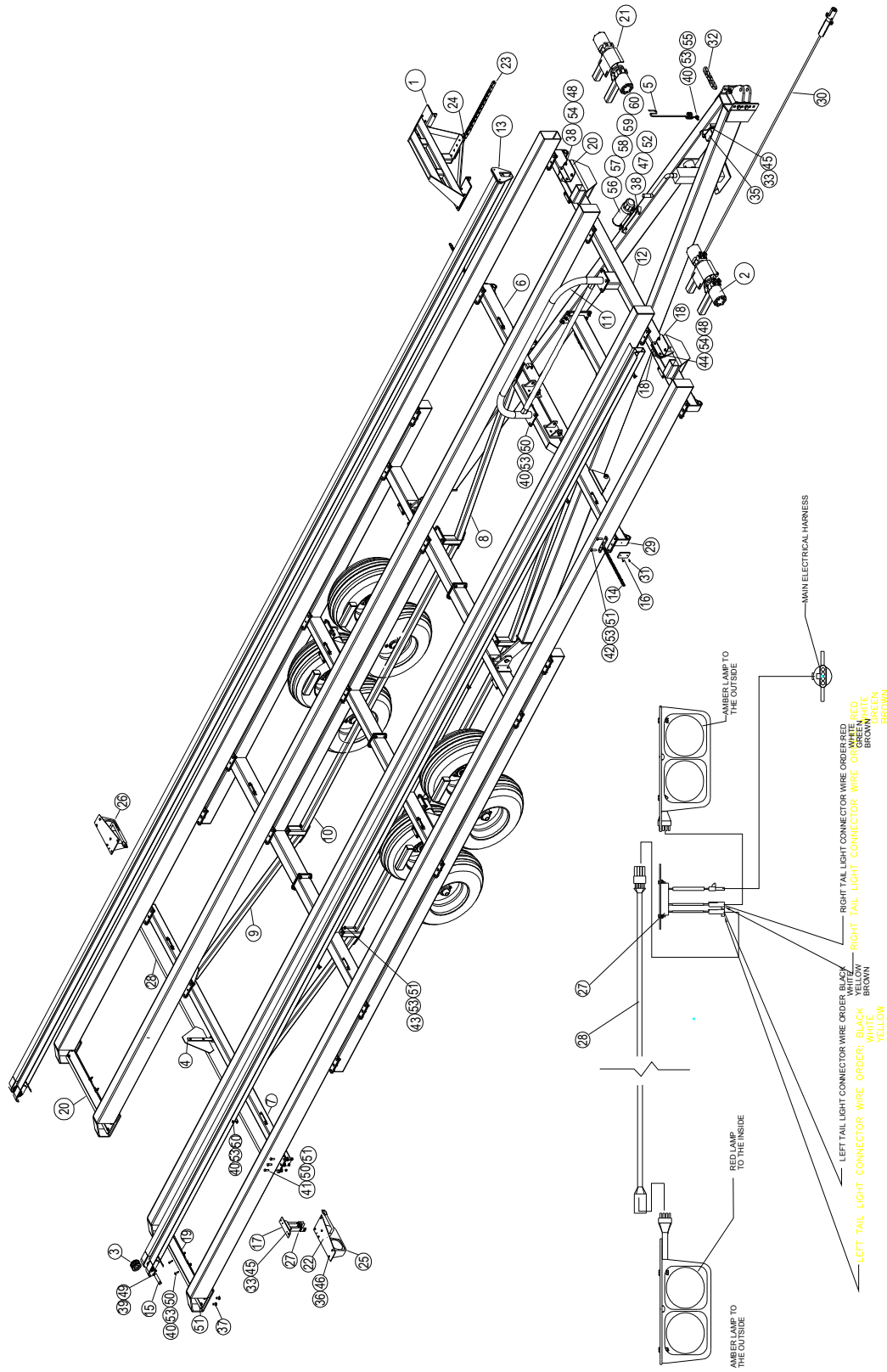

AS VIEWED FROM BACK OF TRAILER

### Carrier Final Assembly (Part # A7000-04)

Item	Part #	Description	Qty
1	A7006-00	PUSHER ASSEMBLY	2
2	A7007-00	MOTOR MOUNT ASSEMBLY	2
3	A7008-00	ROLLER / CHAIN GUIDE ASSEMBLY	2
4	A7017-00	SLOW MOVING VEHICLE ASSEMBLY	1
5	B2363-00	HOSE HOLDER	1
6	C7007-01	SECOND CROSSMEMBER WELDMENT	1
7	C7012-00	REAR CROSSMEMBER WELDMENT	1
8	C7034-00	FRONT BRACE WELDMENT	2
9	C7035-00	REAR BRACE WELDMENT	2
10	C7036-00	CENTER BRACE WELDMENT	2
11	C7048-00	ROLL BAR	1
12	C7054-01	FRONT CROSSMEMBER WELDT	1
13	C7057-01	CHAIN GUIDE WELDT	2
14	C8010-00	SAFETY CHAIN WELDMENT	2
15	E2345-00	CYL PIN / 1.0" X 4 1/4"	2
16	E2413-00	ARM CUSHION	2
17	E2937-00	PLATE 1500/2500 LIGHTING KIT	1
18	E7040-00	CUSHION / PUSHER STOP	2
19	INE7003-01	REAR CHAIN PLATE CROSSMEMBER	2
20	INE7038-00	MOUNTING BRACKET / SHIELD	2
21	INE7039-00	SHIELD / CHAIN DRIVE	2
22	INE7045-00	LIGHT BRACKET PLATE	2
23	52955-456	C2080H ROLLER CHAIN ( 76' PER PUSHER )	152'
24	813643	C2080H CONNECTOR LINK HD	6
25	814195	DUAL LAMP w/BRAKE LH/H RH/V	1
26	814196	DUAL LAMP w/BRAKE RH/H LH/V	1
27	814193	ENHANCED AG LIGHTING MODULE	1
28	814197	EXTENSION HARNESS 114" LG	1
29	813646	GREASE FITTING 1/4 NF DRIVEN	4
30	814198	MAIN HARNESS 48FT LONG 7 PIN PLUG	1
31	813602	RIVET 1/4" X 3/4" FLHD	4
32	813641	SAFETY CHAIN 30M GVW	1
33	813958	SCREW MACH #8-32 X 0.75	6
34	99053	SLIP PLATE BEAM COATING ( NOT VISIBLE)	1 QT.
35	813949	SNUBBER UNIT 1500/2500 BALE CARRIER	1
36	81527	BOLT HEX 0.25NC X 1.00 GR 5 PL	8
37	812217	BOLT CARRIAGE 0.500NC X1.25GR5 PL	8
38	81549	BOLT HEX 0.313NC X 0.75GR5 PL	8
39	811795	BOLT HEX 0.375NC X 2.00GR5 PL	2
40	81620	BOLT HEX 0.500NC X 1.25GR5 PL	41
41	967274	BOLT HEX 0.500NC X 1.50GR8 PL	55
42	967275	BOLT HEX 0.500NC X 2.00GR8 PL	19
43	81629	BOLT HEX 0.500NC X 3.50GR5 PL	4
44	81552	BOLT HEX 0.313 NC X 1.25 GR5PL	4
45	812537	NUT LOCK (NYLOCK) #8-32 STEEL	6
46	81922	NUT LOCK (NYLOCK) 0.25NC GRB PL	8
47	84541	NUT LOCK (NYLON) 0.313NC GRB PL	4
48	812362	NUT LOCK (STEEL) 0.313NC GRB PL	8
49	812363	NUT LOCK (STEEL) 0.375 GRB PL	2
50	812364	NUT LOCK (STEEL) 0.500NC GRB PL	41
51	813663	NUT LOCK (STEEL) 0.500NC GRC PL	86
52	81546	WASHER FLAT STD 0.313 HS PL	1
53	84048	WASHER FLAT SAE 0.500 BS PL	122
54	81570	WASHER FLAT STD 0.375 HS PL	8
55	813581	WASHER FLAT 1.5 X 0.531 X 0.25 PL	1
56	909277	MANUAL HOLDER	1
57	P4186	OPERATOR'S & PARTS MANUAL	1
58	814433	WARRANTY REGISTRATION SHEET	1
59	814449	GOODYEAR TIRE WORKMANSHIP WARRANTY (700-862-905-128)	1
60	814450	GOODYEAR TIRE STUBBLE WARRANTY (700-862-905-129)	1

Carrier Initial Assembly (Part # A7000-04)

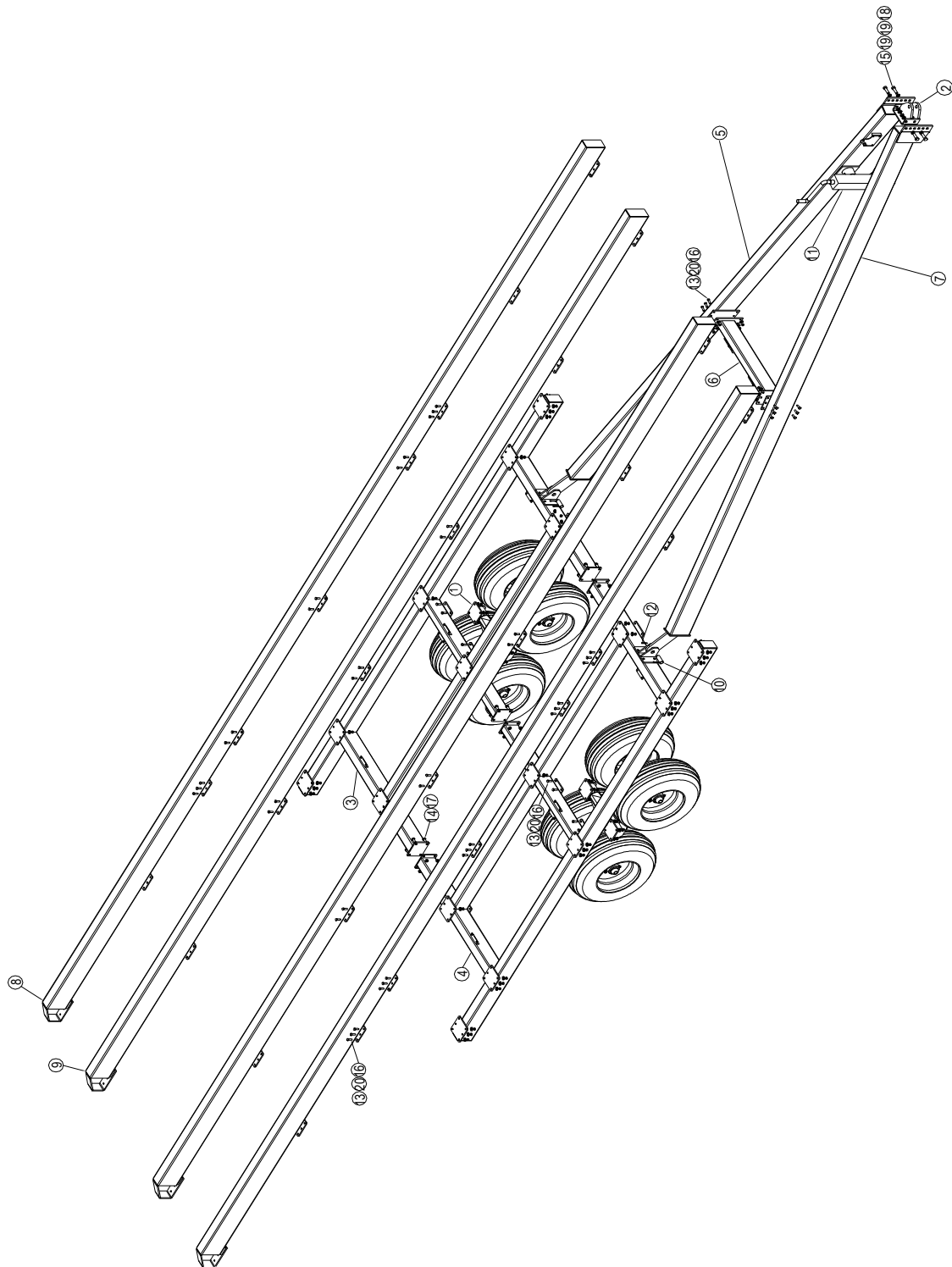

## Carrier Initial Assembly (Part # A7000-04)

Item	Component Part #	Description	Qty
1	A7004-00	TANDEM AXLE ASSEMBLY	2
2	C2369-00	HITCH CLEVIS WELDMENT	1
3	C7000-01	LEFT SUBFRAME	1
4	C7001-01	RIGHT SUBFRAME	1
5	C7006-00	LEFT HITCH BEAM WELDMENT	1
6	C7008-00	HITCH CROSSMEMBER WELDMENT	1
7	C7016-00	RIGHT HITCH BEAM WELDMENT	1
8	C7055-00	OUTER CARRIER BEAM	2
9	C7056-00	INNER CARRIER BEAM	2
10	E2348-00	HITCH BEAM PIN	2
11	813685	5 TON SCREW JACK	1
12	81207	COTTER PIN 0.188 X 2.00 POL	4
13	967274	BOLT HEX 0.500NC X 1.50GR8 PL	100
14	813053	BOLT HEX 0.625NC X 1.50GR8 PL	12
15	813515	BOLT HEX 0.750NC X 2.50GR8 PL	4
16	813663	NUT LOCK (STEEL) 0.500NC GRC PL	100
17	813731	NUT LOCK (STEEL) 0.625NC L9 PL	12
18	813648	NUT LOCK (STEEL) 0.750NC GRC PL	4
19	813590	WASHER FLAT 1.25X0.781X0.25 PL	8
20	84048	WASHER FLAT SAE 0.500 BS PL	100

**Tandem Axle Assembly (Part # A7004-00)**

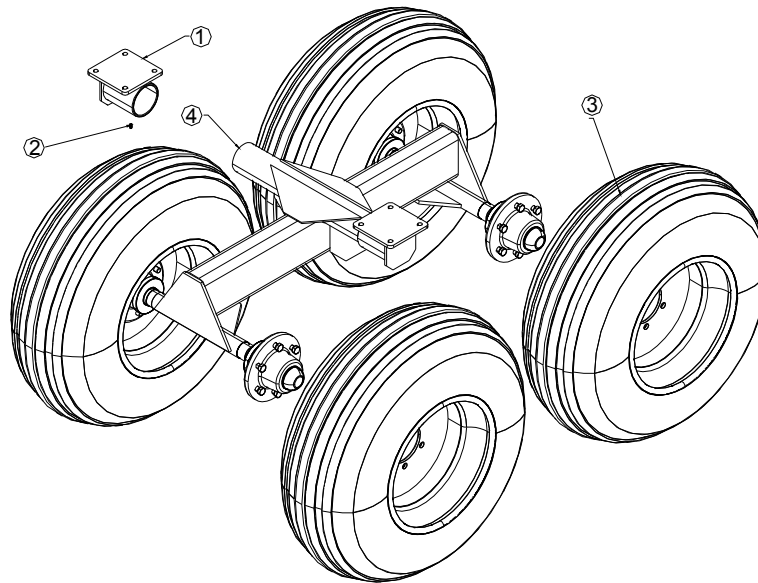

Item	Component Part #	Description	Qty
1	C2322-00	AXLE BEARING WELDMENT	2
2	813646	GREASE ZERK 1/4" SELF TAPPING	2
3	B2700-03	TIRE ASSEMBLY	4
4	B2722-00	TANDEM AXLE 2500/4000 BALE CARRIER	1

## Tire Assembly (Part # B2700-03)

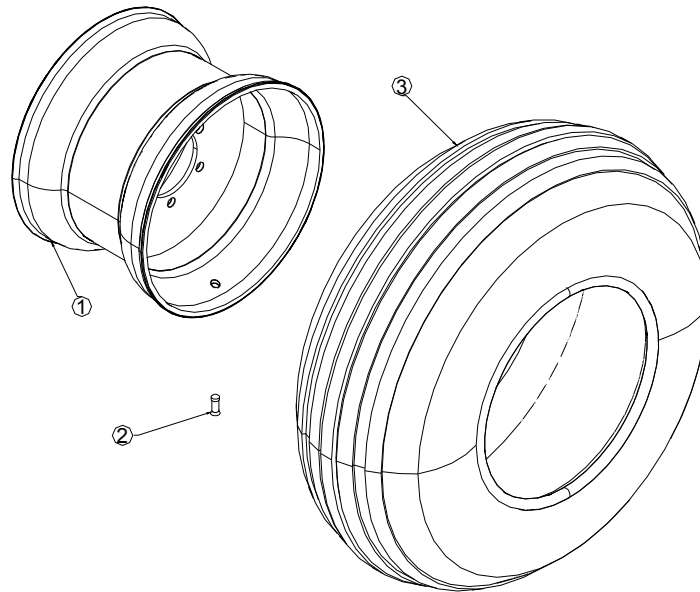

Item	Component Part #	Description	Qty
1	813655	15 X 10lb X 6 BOLT P65 RIM	4
2	813656	TR-416-MS VALVE STEM WITH CAP	1
3	813657	TIRE 12.5 X 15FI 12 PLY RANGE F FARM HWY TIRE	1

**Tandem Axle Assembly (Part # B2722-00)**

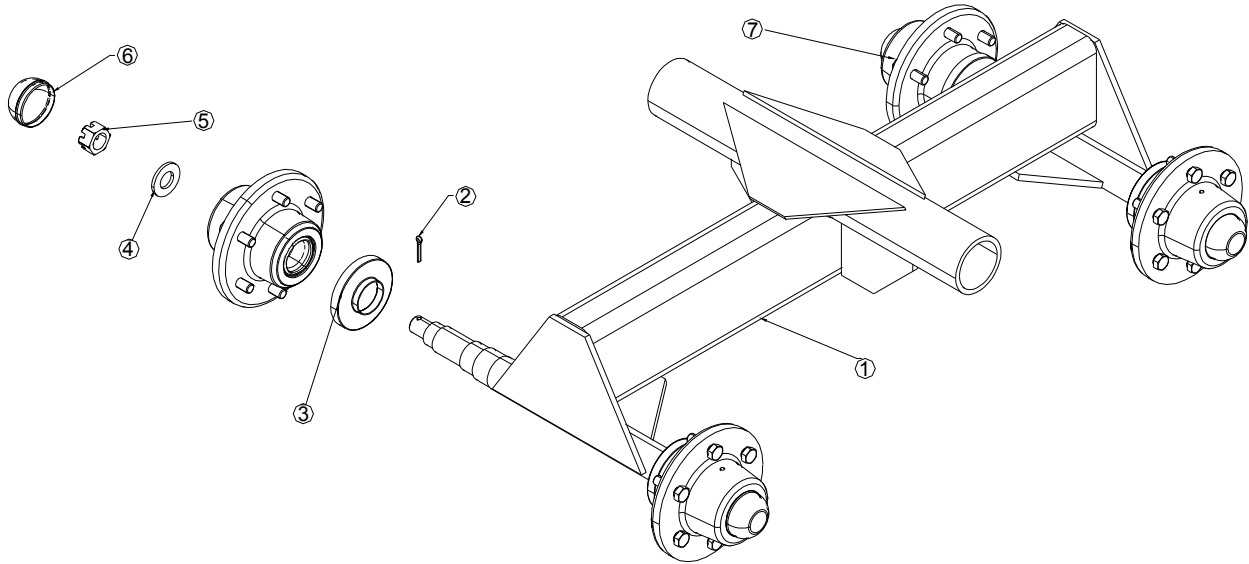

4

Item	Component Part #	Description	Qty
1	C2722-00	TANDEM AXLE WELDMENT	1
2	81206	3/16" X 1-1/2 " COTTER PIN BLACK	4
3	813649	DUST SHIELD	4
4	813651	WASHER FLAT 1-1/32" X 2" X .188" BLK.	4
5	813673	NUT CASTLE 1.00 NF	4
6	813650	DUST CAP	4
7	C2339-00	HUB ASSEMBLY	4



## Hub Assembly (Part # C2339-00)

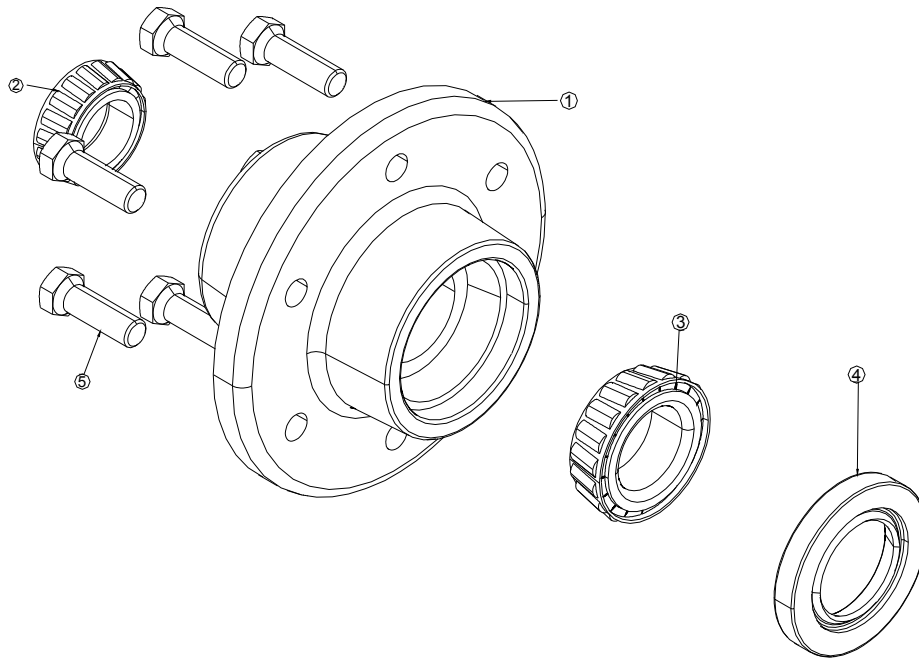

Item	Component Part #	Description	Qty
1	813652	6 BOLT WHEEL HUB	1
2	967205	BEARING CONE OUTER	1
3	967208	BEARING CONE INNER	1
4	967204	OIL SEAL SAE-30	1
5	813653	9/16" HUB BOLT	6

Pusher Assembly (Part # A7006-00) \*\*

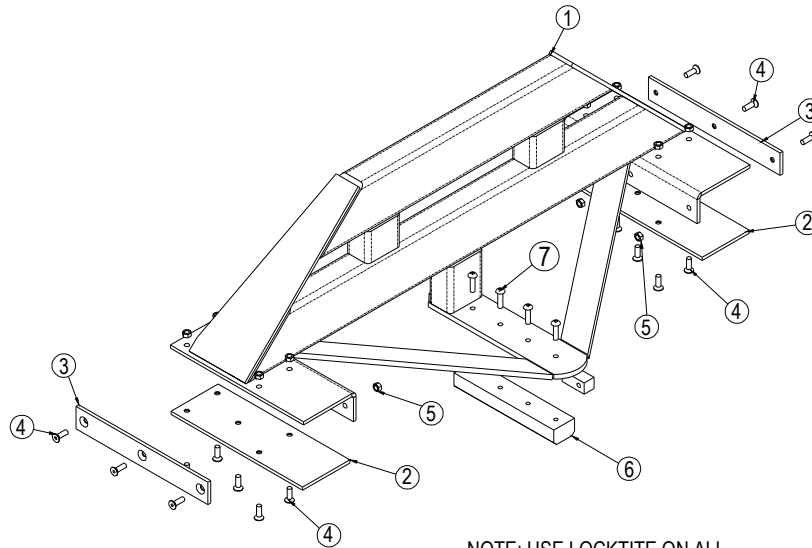

NOTE: USE LOCKTITE ON ALL BRASS SCREWS

Item	Component Part #	Description	Qty
1	C7027-00	PUSHER	1
2	E2749-00	TOP SLIDER	2
3	E2750-00	SIDE SLIDER	2
4	813558	SCREW MACH M8 X 20 FLHD BRASS	16
5	813561	NUT HEX M8 BRASS	16
6	E7032-00	CENTER SLIDER	1
7	813644	SCREW MACH 0.313NC X 1.25 RDHD	4

(\*\*) Note: Two pushers are installed.

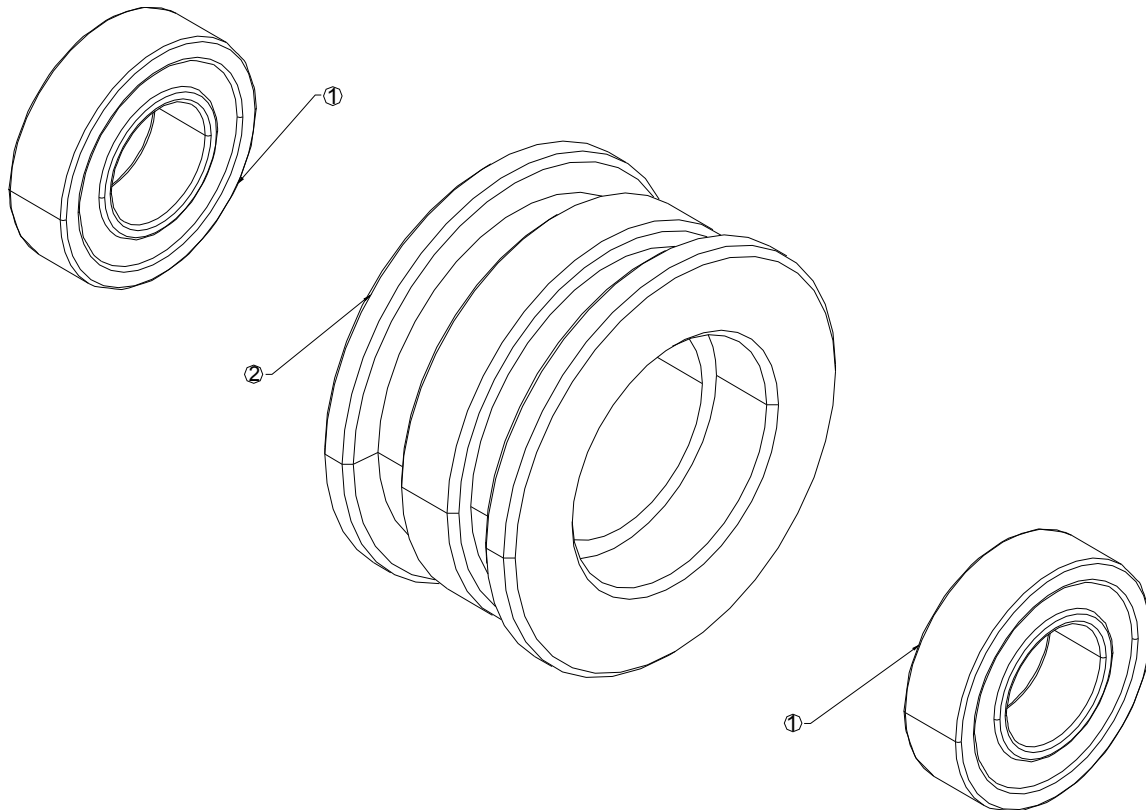
**Roller / Chain Guide Assembly (Part # A7008-00)**

Item	Component Part #	Description	Qty
1	813645	BEARING / 6205LLU/25.4/3E	2
2	INE7037-00	ROLLER / CHAIN GUIDE	1

Fixed Pick Up Arm Assembly LH Side (Part # A2300-86)

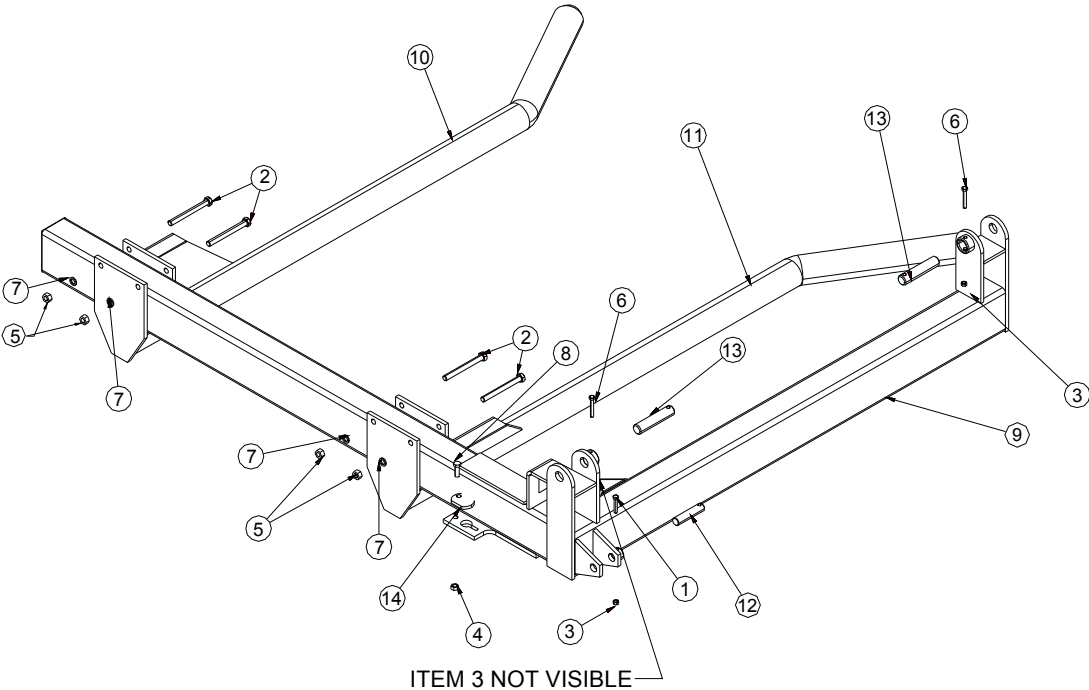

**Fixed Pick Up Arm Assembly LH Side (Part # A2300-86)**

<b>Item</b>	<b>Component Part #</b>	<b>Description</b>	<b>Qty</b>
1	811795	BOLT HEX 0.375 NC X 2.00 GR5PL	1
2	812087	BOLT HEX 0.625 NC X 6.00 GRBPL	4
3	812363	NUT LOCK (STEEL) 0.375 NC GRBPL	3
4	812364	NUT LOCK (STEEL) 0.500 NC GR5PL	1
5	813509	NUT HEX 0.625 NC GR5PL	4
6	81581	BOLT HEX 0.375 NC X 2.50 GR5PL	2
7	81677	WASHER LOCK 0.625 PL	4
8	84277	BOLT HEX 0.500 NC X 1.50 GR5PL	1
9	C2315-00	LIFT ARM LEFT BALE	1
10	C2329-00	FORK BALE LEFT ASSEMBLY	1
11	C2330-00	FORK BALE RIGHT ASSEMBLY	1
12	E2345-00	PIN CYLINDER 1.0 DIA X 4.5	1
13	E2445-00	PIN LIFT ARM 1.25 DIA C1045 CR	2
14	INE2485-00	CHAIN LATCH LIFT ARM	1

## Fixed Pick Up Arm Assembly RH Side (Part # A2300-87)

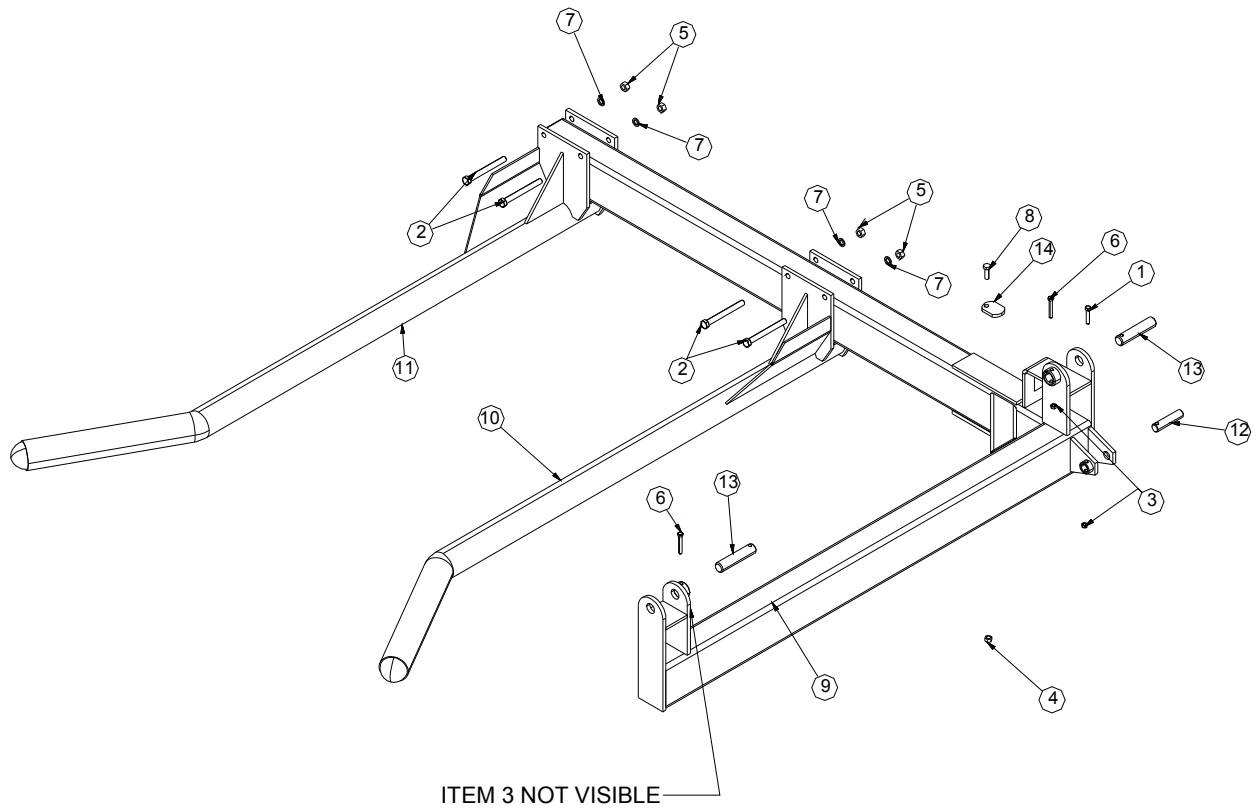

**Fixed Pick Up Arm Assembly RH Side (Part # A2300-87)**

<b>Item</b>	<b>Component Part #</b>	<b>Description</b>	<b>Qty</b>
1	811795	BOLT HEX 0.375 NC X 2.00 GR5PL	1
2	812087	BOLT HEX 0.625 NC X 6.00 GRBPL	4
3	812363	NUT LOCK (STEEL) 0.375 NC GRBPL	3
4	812364	NUT LOCK (STEEL) 0.500 NC GR5PL	1
5	813509	NUT HEX 0.625 NC GR5PL	4
6	81581	BOLT HEX 0.375 NC X 2.50 GR5PL	2
7	81677	WASHER LOCK 0.625 PL	4
8	84277	BOLT HEX 0.500 NC X 1.50 GR5PL	1
9	C2316-00	LIFT ARM RIGHT BALE	1
10	C2329-00	FORK BALE LEFT ASSEMBLY	1
11	C2330-00	FORK BALE RIGHT ASSEMBLY	1
12	E2345-00	PIN CYLINDER 1.0 DIA X 4.5	1
13	E2445-00	PIN LIFT ARM 1.25 DIA C1045 CR	2
14	INE2485-00	CHAIN LATCH LIFT ARM	1

RPU Assembly LH Side (Part # A2400-34)

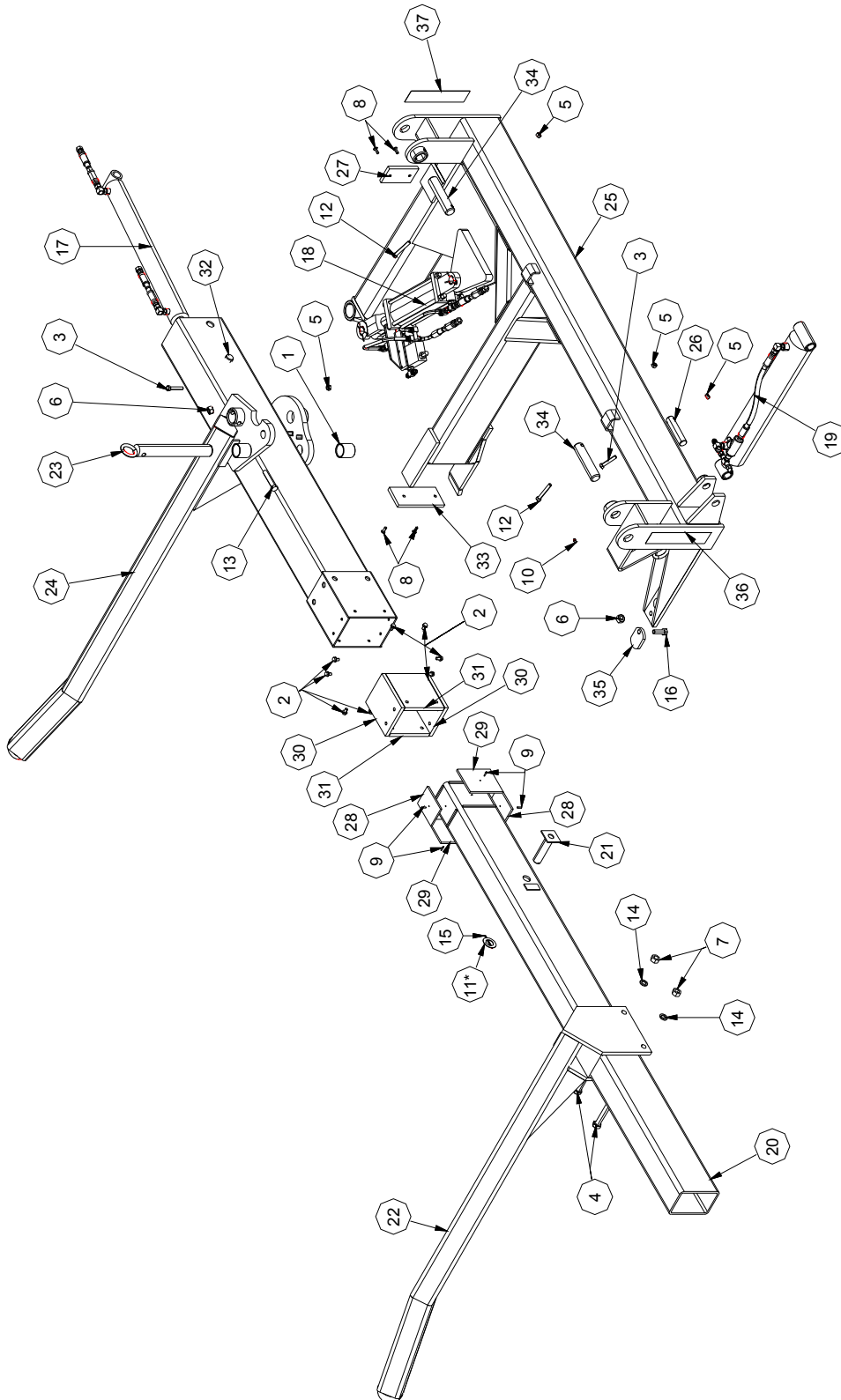



**RPU Assembly LH Side (Part # A2400-34)**

ITEM	COMPONENT PART#	DESCRIPTION	QTY
1	20252	BUSHING 1.75OD x 1.5ID x 1.75	2
2	810215	SCREW SELF TAP 0.313 NC X 0.50	8
3	811795	BOLT HEX 0.375NC X 2.00 GR5 PL	2
4	812087	BOLT HEX 0.625NC X 6.00 GRBPL	2
5	812363	NUT LOCK (STEEL) 0.375 GRB PL	4
6	812364	NUT LOCK (STEEL) 0.500NC GRB PL	2
7	813509	NUT HEX 0.625 NC GR5PL	2
8	813602	RIVET 1/4 X 3/4 FLATHEAD	4
9	813611	PIN SPRING 0.125 DIA X 0.625 LONG	4
10	813646	GREASE FITTING 1/4 NF DRIVEN	1
11*	813795	WASHER FLAT 1.031 X 1.75 X 0.031	1
12	81581	BOLT HEX 0.375NC X 2.50 GR5PL	2
13	81626	BOLT HEX 0.500NC X 2.75 GR5PL	1
14	81677	WASHER LOCK 0.625 PL	2
15	81978	COTTER PIN 0.125 X 2.00 POL	1
16	84277	BOLT HEX 0.500NC X 1.50 GR5PL	1
17	A2400-35	SQUEEZE CYLINDER ASSEMBLY RPU	1
18	A2400-36	ROTATE CYLINDER ASSEMBLY RPU	1
19	A2400-37	PILOT CHECK VALVE ASSY RPU	1
20	C2417-00	SLIDING ARM RPU	1
21	C2423-00	PIN SQUEEZE CYLINDER RPU	1
22	C2428-00	FORK ADJUSTABLE RPU LH	1
23	C2695-00	PIN HINGE RPU	1
24	C2696-00	LH STATIONARY ARM RPU	1
25	C2697-00	LIFT ARM RPU, LH	1
26	E2345-00	PIN CYLINDER 1.0 DIA X 4.5	1
27	E2413-00	ARM CUSHION RUBBER BELTING	1
28	E2419-00	ARM SLIDING TOP AND BOTTOM PAD	2
29	E2420-00	ARM SLIDING SIDE PAD	2
30	E2421-00	STATIONARY ARM TOP AND BOTTOM RPU PAD	2
31	E2422-00	ARM STATIONARY SIDE RPU PAD	2
32	E2424-00	PIN SQUEEZE CYLINDER CLEVIS	1
33	E2429-00	ARM STATIONARY CUSHION RPU	1
34	E2445-00	PIN LIFT ARM 1.25 DIA C1045CR	2
35	E2485-00	CHAIN LATCH LIFT ARM	1
36	967053	DECAL REFLECTIVE 2 X 9 RED	1
37	967055	DECAL REFLECTIVE 2 X 9 AMBER	1

Note: 1. Item #11 is used as needed.

RPU Assembly RH Side (Part # A2400-32) (Optional)

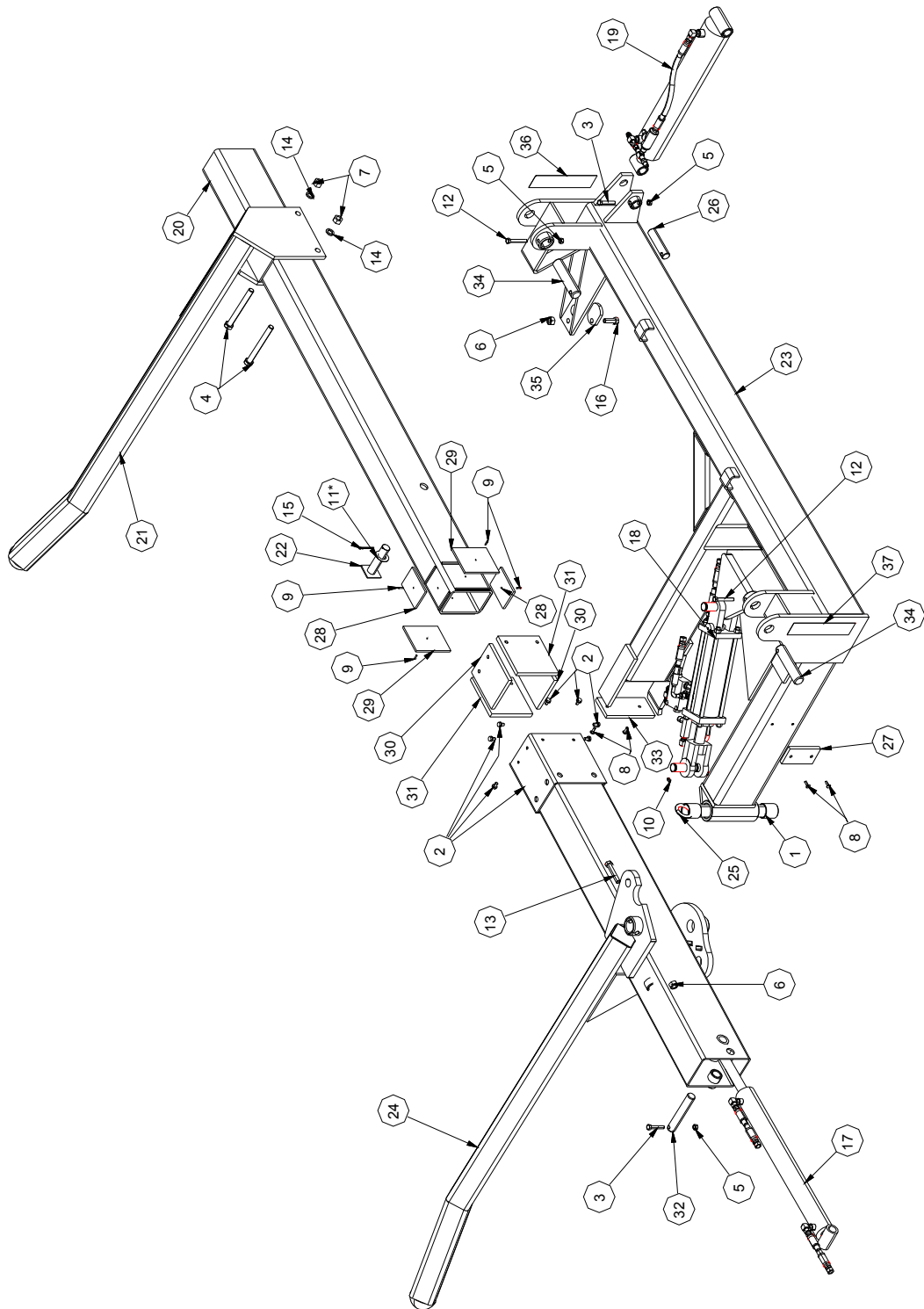

**RPU Assembly RH Side (Part # A2400-32) (Optional)**

ITEM	Component part #	DESCRIPTION	QTY
1	20252	BUSHING 1.75OD x 1.5ID x 1.75	2
2	810215	SCREW SELF TAP 0.313 NC X 0.50	8
3	811795	BOLT HEX 0.375NC X 2.00 GR5 PL	2
4	812087	BOLT HEX 0.625NC X 6.00 GRBPL	2
5	812363	NUT LOCK (STEEL) 0.375 GRB PL	4
6	812364	NUT LOCK (STEEL) 0.500NC GRB PL	2
7	813509	NUT HEX 0.625 NC GR5PL	2
8	813602	RIVET 1/4 X 3/4 FLATHEAD	4
9	813611	PIN SPRING 0.125 DIA X 0.625 LONG	4
10	813646	GREASE FITTING 1/4 NF DRIVEN	1
11*	813795	WASHER FLAT 1.031 X 1.75 X 0.031	1
12	81581	BOLT HEX 0.375NC X 2.50 GR5PL	2
13	81626	BOLT HEX 0.500NC X 2.75 GR5PL	1
14	81677	WASHER LOCK 0.625 PL	2
15	81978	COTTER PIN 0.125 X 2.00 POL	1
16	84277	BOLT HEX 0.500NC X 1.50 GR5PL	1
17	A2400-35	SQUEEZE CYLINDER ASSEMBLY RPU	1
18	A2400-36	ROTATE CYLINDER ASSEMBLY RPU	1
19*	A2400-37	PILOT CHECK VALVE ASSY RPU	1
20	C2417-00	SLIDING ARM RPU	1
21	C2418-00	FORK ADJUSTABLE RH RPU	1
22	C2423-00	PIN SQUEEZE CYLINDER RPU	1
23	C2499-00	LIFT ARM RIGHT	1
24	C2694-00	RH STATIONARY ARM RPU	1
25	C2695-00	PIN HINGE RPU	1
26	E2345-00	PIN CYLINDER 1.0 DIA X 4.5	1
27	E2413-00	ARM CUSHION RUBBER BELTING	1
28	E2419-00	ARM SLIDING TOP AND BOTTOM PAD	2
29	E2420-00	ARM SLIDING SIDE PAD	2
30	E2421-00	STATIONARY ARM TOP AND BOTTOM RPU PAD	2
31	E2422-00	ARM STATIONARY SIDE RPU PAD	2
32	E2424-00	PIN SQUEEZE CYLINDER CLEVIS	1
33	E2429-00	ARM STATIONARY CUSHION RPU	1
34	E2445-00	PIN LIFT ARM 1.25 DIA C1045CR	2
35	E2485-00	CHAIN LATCH LIFT ARM	1
36	967053	DECAL REFLECTIVE 2 X 9 RED	1
37	967055	DECAL REFLECTIVE 2 X 9 AMBER	1

Note: 1. Item #11 is used as needed.  
 2. Item #19 is an existing part installed on carrier.

Bale Deflector Assembly LH (Part # A2400-17)

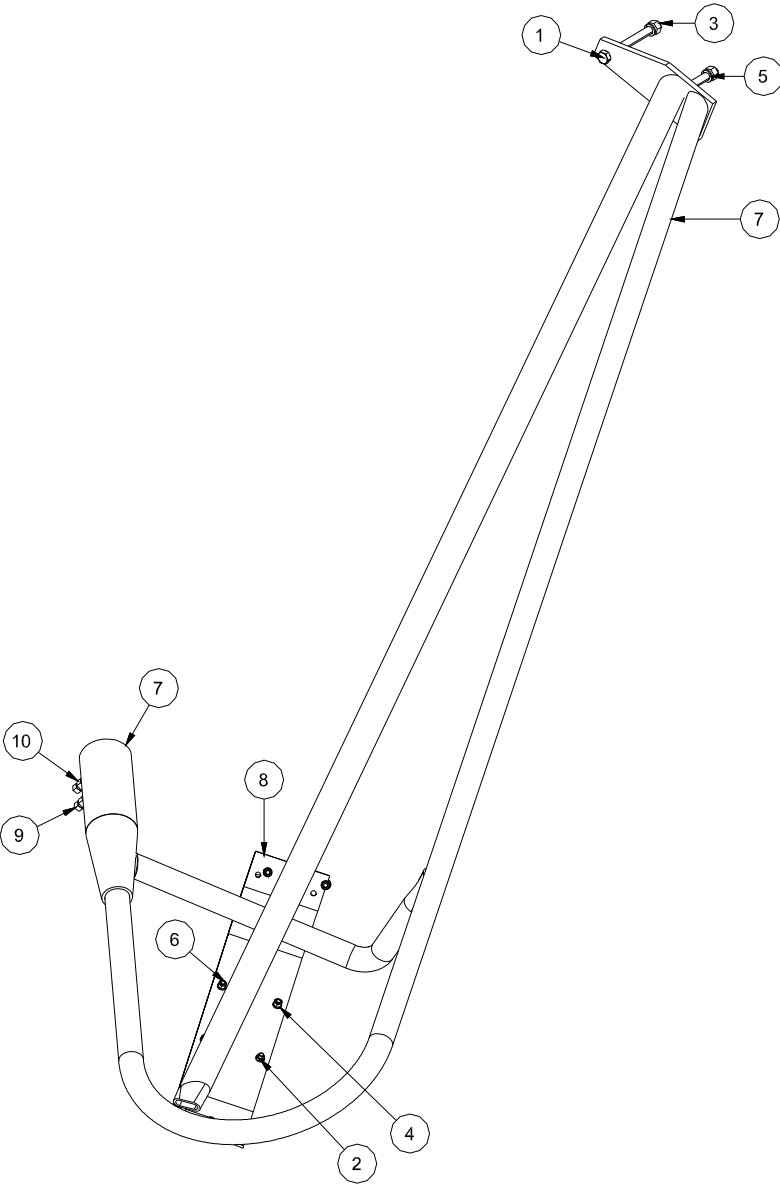

**Bale Deflector Assembly LH (Part # A2400-17)**

<b>Item</b>	<b>Component Part #</b>	<b>Description</b>	<b>Qty</b>
1	812076	BOLT HEX 0.625 NC X 6.50 GR5PL	2
2	813507	NUT HEX 0.375 NC GR5PL	9
3	813509	NUT HEX 0.625 NC GR5PL	2
4	81593	WASHER 0.375 LOCK PL	9
5	81677	WASHER LOCK 0.625 PL	2
6	81914	BOLT CARR 0.375 NC X 1.00 GR5PL	9
7	C2452-00	BALE DEFLECTOR LH MAIN FRAME	1
8	E2456-00	SKID COVER LH UHMW POLY	1
9	813547	SET SCREW SQHDCUP 0.500 NC	2
10	813508	NUT HEX 0.500NC GR5PL	2

Bale Deflector Assembly RH (Part # A2400-16)

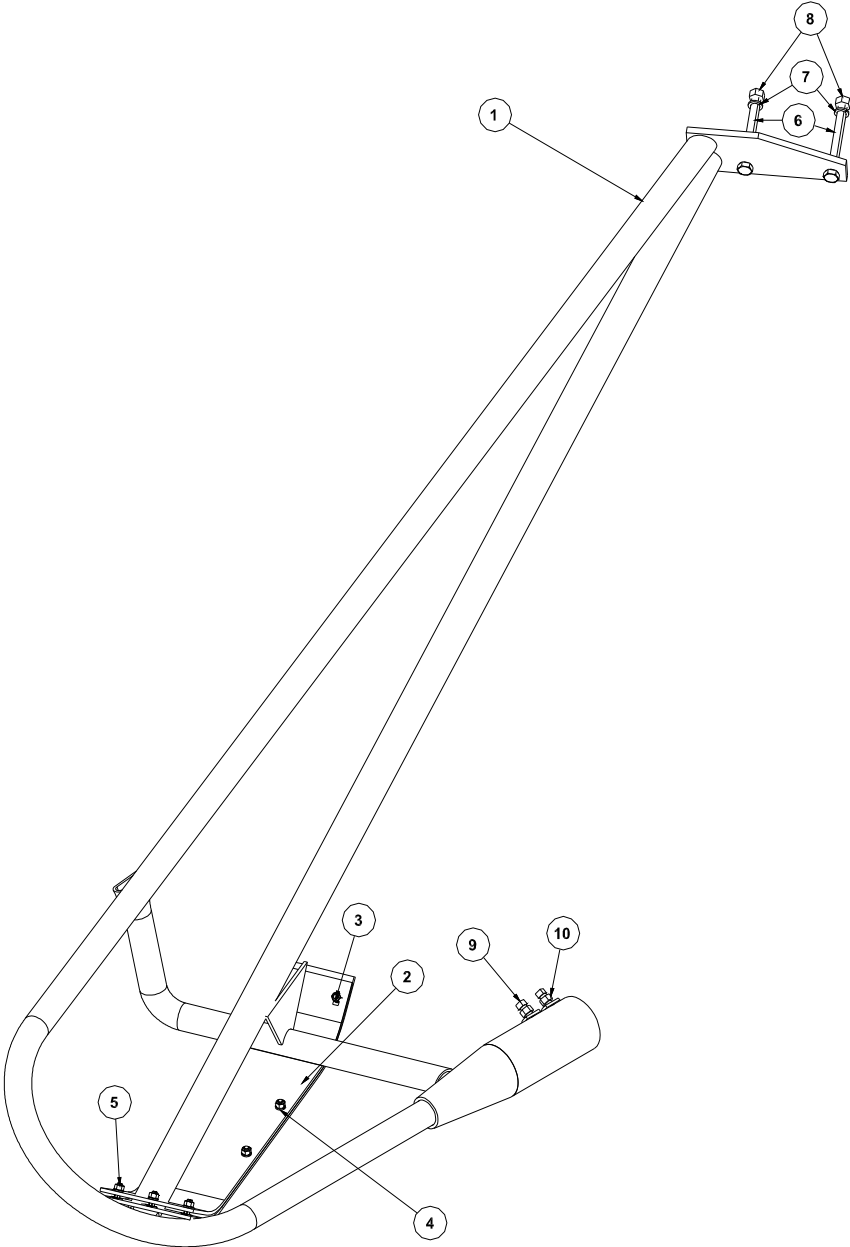

**Bale Deflector Assembly RH (Part # A2400-16)**

<b>Item</b>	<b>Component Part #</b>	<b>Description</b>	<b>Qty</b>
1	C2451-00	BALE DEFLECTOR RH MAIN FRAME	1
2	E2453-00	SKID COVER RH UHMW POLY	1
3	81914	BOLT CARR 0.375 NC X 1.00 GR5PL	9
4	81593	WASHER 0.375 LOCK PL	9
5	813507	NUT HEX 0.375 NC GR5PL	9
6	812076	BOLT HEX 0.625 NC X 6.50 GR5PL	2
7	81677	WASHER LOCK 0.625 PL	2
8	813509	NUT HEX 0.625 NC GR5PL	2
9	813547	SET SCREW SQHDCUP 0.500 NC	2
10	813508	NUT HEX 0.500 NC GR5PL	2

**Slow Moving Vehicle Sign Assembly (Part # A7017-00)**

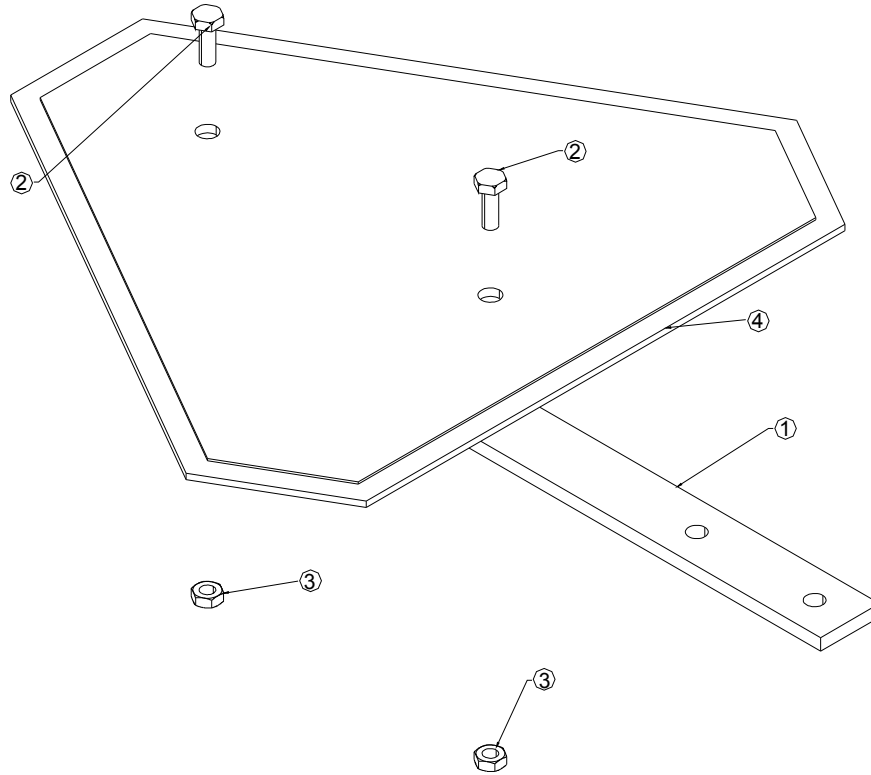

Item	Component Part #	Description	Qty
1	E2795-00	DECAL MOUNT SLOW MOVING VEHICLE SIGN	1
2	81525	BOLT HEX 0.25 NC X 0.75 GR5PL	2
3	84498	NUT LOCK (STEEL) 0.25 GRBPL	2
4	967066	SLOW MOVING VEHICLE DECAL	1



**CHECKLIST****Pre-delivery**

---

- Verify Hardware Torque
- Verify Rear Wheel Bolt Torque
- Verify Tire Pressure
- Inspect Bearing Seals
- Inspect All Lubrication Points
- Inspect Chain Drives
- Inspect Hydraulic Hoses and Electrical Harnesses

Dealer Representative: \_\_\_\_\_

Date: \_\_\_\_\_

**Customer Delivery**

---

- Review safety procedures regarding 2500 Bale Carrier operation and maintenance.
- Review *Operator's and Part's Manual*.
- Review proper operating procedures.
- Review general adjustment and setup procedures.
- Review chain tensioning procedures.
- Review importance of regular lubrication.
- Discuss road and highway transportation requirements and regulations.
- Review front hitch height.

Dealer Representative: \_\_\_\_\_

Date: \_\_\_\_\_

NOTES PAGE

## DIVISION LOCATIONS

Inland Division  
1260 Clarence Avenue  
Winnipeg, Manitoba R3T 1T2  
Ph.: (204) 661-8711  
Fax: (204) 654-2503

Allied Division  
1260 Clarence Avenue  
Winnipeg, Manitoba R3T 1T2  
Ph.: (204) 661-8711  
Fax: (204) 654-2503

Farm King Division  
301 Mountain Street S.  
Morden MB.  
R6M 1X7  
Ph.: (204) 822-4467  
Fax: (204) 822-6348

B.I.I. Division  
1330 43<sup>rd</sup> Street N.W.  
Fargo, ND 58102  
Ph: (701) 282-7014  
Fax: (701) 282-5865

## CANADIAN WAREHOUSES

B.C., Abbotsford  
(604) 864-2665

AB, Edmonton  
(403) 962-6991

SK, Regina  
(306) 781-2300

ON, Woodstock  
(519) 539-0435

ON, Jasper  
(613) 283-1758

QC, Dorion  
(450) 455-4840

## U.S. WAREHOUSES

AR, West Memphis  
(870) 732-3132

GA, Stone Mountain  
(770) 908-9439

IA, Lakeview  
(712) 657-8585

ID, Meridian  
(208) 887-6006

IN, Clarksville  
(812) 284-3376

KS, Wichita  
(316) 265-9577

MN, Lakeville  
(952) 469-5267

MT, Billings  
(406) 248-7771

ND, Bismarck  
(701) 223-1886

ND, Fargo  
(701) 282-7003

NY, Syracuse  
(315) 463-5276

OH, Youngstown  
(330) 793-0862

OR, Portland  
(503) 234-0378

SD, Huron  
(605) 352-8616

TX, Houston  
(713) 928-2632

UT, Salt Lake City  
(801) 972-4321

WI, Portage  
(608) 742-1370

## OFFSHORE WAREHOUSES

Burando Hill  
Katanning  
W. Australia  
011-618-98-214422

Chihuahua, Mexico  
011-52-158-90306

John Kerr Equipment Ltd.  
Wilcoxholm Farm  
Linlithgow, W. Lothian  
Scotland  
011-441-506-842280

Skovde, Sweden  
011-46-500-452651

Naestved, Denmark  
011-45-557-29511

# bühler

Buhler Manufacturing *"a partnership"*

1260 Clarence Avenue  
Winnipeg, Manitoba R3T 1T2  
Ph.: (204) 661-8711  
Fax: (204) 654-2503  
Toll Free: 888-524-1003  
E-mail: [info@buhler.com](mailto:info@buhler.com)  
[www.buhler.com](http://www.buhler.com)

Printed in U.S.A.