

Farm King

OPERATOR AND PARTS MANUAL

Fertilizer Applicator

Model 1840



042017

88670897

TABLE OF CONTENTS

Manufacturer’s Statement: For technical reasons, Buhler Industries Inc. reserves the right to modify machinery design and specifications provided herein without any preliminary notice. Information provided herein is of descriptive nature. Performance quality may depend on soil fertility, applied agricultural techniques, weather conditions and other factors.

INTRODUCTION7

SAFETY13

ASSEMBLY27

OPERATION37

MAINTENANCE63

PARTS IDENTIFICATION79

SPECIFICATIONS201

WARRANTY213

ALPHABETICAL INDEX217

Farm King



WARRANTY REGISTRATION FORM

This form must be filled out by the dealer and signed by both the dealer and the customer at the time of delivery.

Customer Name:	Dealer Name:		
Customer Address:	Dealer Address:		
City:	Prov / State:	City:	Prov / State:
Postal / Zip Code:	Phone:	Postal / Zip Code:	Phone:

Fertilizer Applicator Model:	Serial Number:	Delivery Date:
------------------------------	----------------	----------------

I have thoroughly instructed the buyer on the above described equipment which review included the Operator and Parts Manual content, equipment care, adjustments, safe operation and applicable warranty policy.

Dealer Inspection Report

<input type="checkbox"/>	Toolbar Moves Up / Down Freely
<input type="checkbox"/>	Inner And Outer Wings Fold / Extend Freely
<input type="checkbox"/>	Wheel Bolts Are Tight
<input type="checkbox"/>	Monitors Function Correctly
<input type="checkbox"/>	Hydraulic / Application Hoses And Fittings Tight
<input type="checkbox"/>	All Fasteners Are Tight
<input type="checkbox"/>	Lubricate Machine
<input type="checkbox"/>	Check Tire Pressure

Safety

<input type="checkbox"/>	All Lights And Reflectors Installed
<input type="checkbox"/>	All Lights And Reflectors Cleaned And Working
<input type="checkbox"/>	Safety Chain On Hitch
<input type="checkbox"/>	All Decals Installed
<input type="checkbox"/>	Guards And Shields Installed And Secure
<input type="checkbox"/>	Review Operating And Safety Instructions
<input type="checkbox"/>	Check For Hydraulic Leaks

Date:	Dealer Rep. Signature:
-------	------------------------

The above equipment and Operator And Parts Manual have been received by me and I have been thoroughly instructed as to care, adjustments, safe operation and applicable warranty policy.

Date:	Customer / Owner's Signature:
-------	-------------------------------

Remove this Warranty Registration Form from the Operator And Parts Manual. Make two copies of the form. Send original Warranty Registration Form to Farm King. Give one copy to the customer and the dealer will keep one copy.

Farm King



INTRODUCTION

This Operator And Parts Manual was written to give the owner / operator instructions on the safe operation, maintenance and part identification of the Farm King equipment. **READ AND UNDERSTAND THIS OPERATOR AND PARTS MANUAL BEFORE OPERATING YOUR FARM KING EQUIPMENT.** If you have any questions, see your Farm King dealer. This manual may illustrate options and accessories not installed on your Farm King equipment.

OWNER'S INFORMATION9
 Serial Number Location9
 Manual Storage9

EQUIPMENT IDENTIFICATION10
 Component Location10

Farm King



OWNER’S INFORMATION

Thank you for your decision to purchase a Farm King 1840 Fertilizer Applicator. To ensure maximum performance of your equipment, it is mandatory that you thoroughly study the Operator And Parts Manual and follow the recommendations. Proper operation and maintenance are essential to maximize equipment life and prevent personal injury.

Operate and maintain this equipment in a safe manner and in accordance with all applicable local, state, and federal codes, regulations and / or laws. Follow all on-product labeling and instructions.

Make sure that all personnel have read this Operator And Parts Manual and thoroughly understand safe and correct operating, installation and maintenance procedures.

Farm King is continually working to improve its products. Farm King reserves the right to make any improvements or changes as deemed practical and possible without incurring any responsibility or obligation to make any changes or additions to equipment sold previously.

Although great care has been taken to ensure the accuracy of this publication, Farm King makes no warranty or guarantee of any kind, written or expressed, implied or otherwise with regard to the information contained within this manual. Farm King assumes no responsibility for any errors that may appear in this manual and shall not be liable under any circumstances for incidental, consequential or punitive damages in connection with, or arising from the use of this manual.

Keep this manual available for frequent reference. All new operators or owners must review the manual before using the equipment and annually thereafter. Contact your Farm King Dealer if you need assistance, information, or additional copies of the manual. Visit our website at www.farm-king.com for a complete list of dealers in your area.

The directions left, right, front and rear, as mentioned throughout this manual, are as viewed by the operator sitting in the tractor seat while towing the applicator.

Serial Number Location

Please enter the model and serial number in the space provided for easy reference.

Figure 1

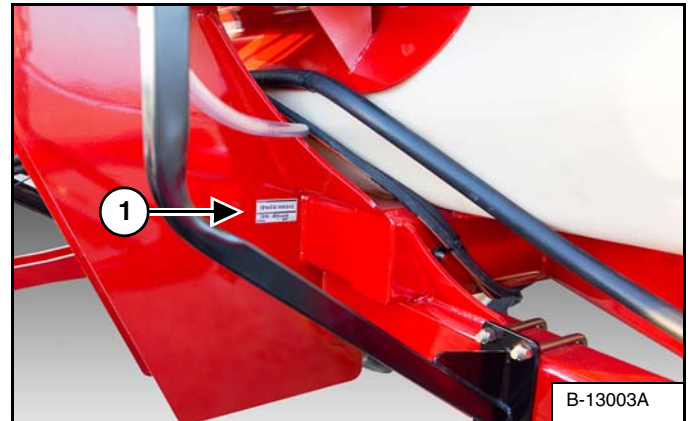

Model Number: _____

Serial Number: _____

The serial number plate (Item 1) [Figure 1] is located on the left side of the hitch frame, directly above the toolbar.

Always use your serial number when requesting information or when ordering parts.

Manual Storage

Figure 2

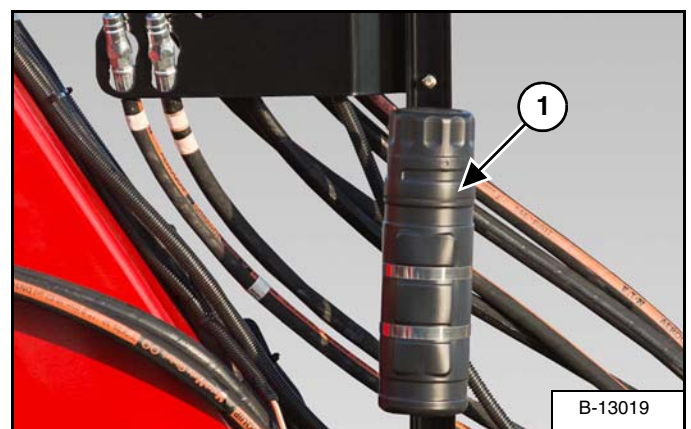

The operator and parts manual and other documents can be stored in the canister (Item 1) [Figure 2] located behind the hitch on the front of the fertilizer applicator.

EQUIPMENT IDENTIFICATION

Component Location

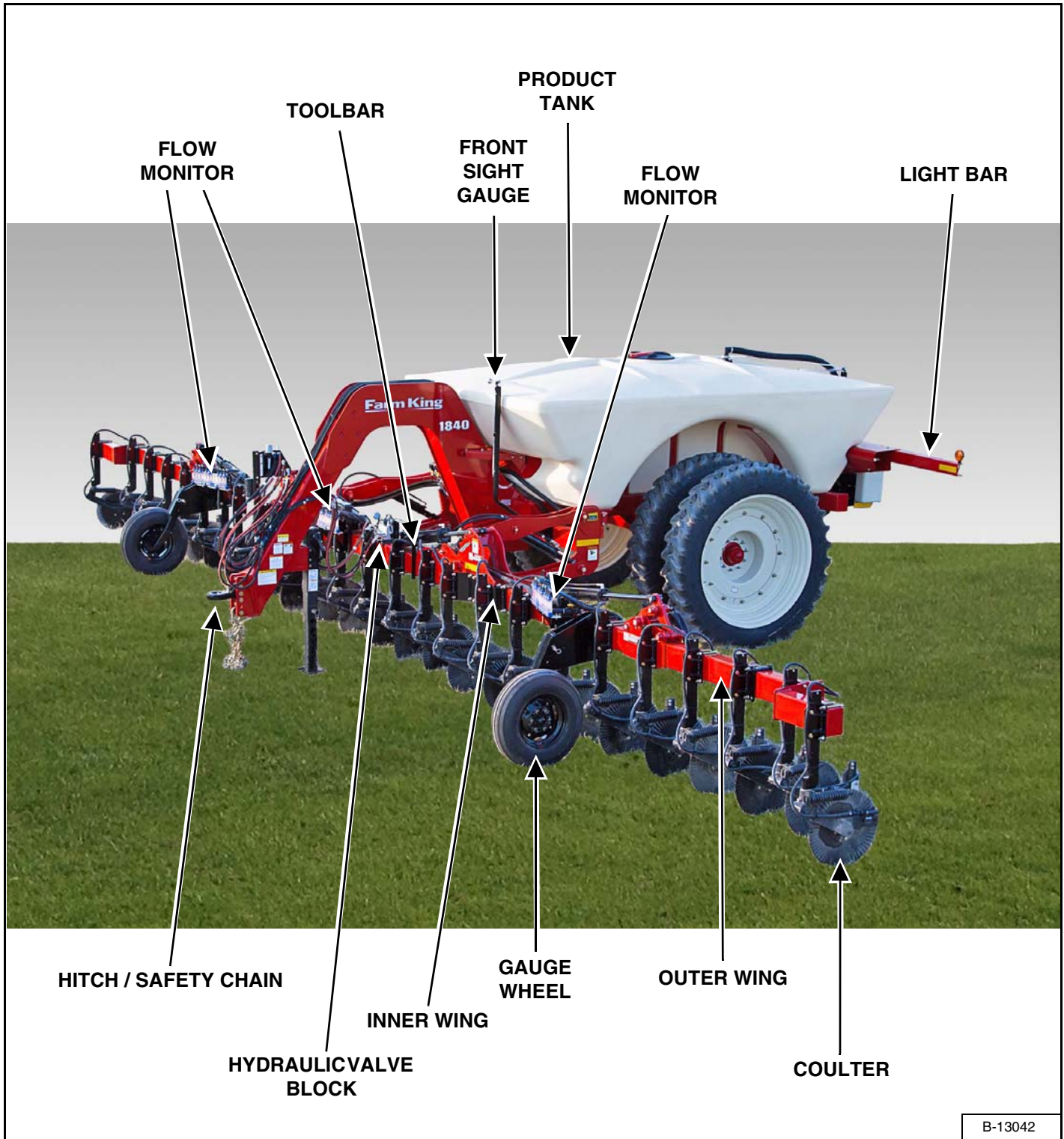

B-13042

Component Location

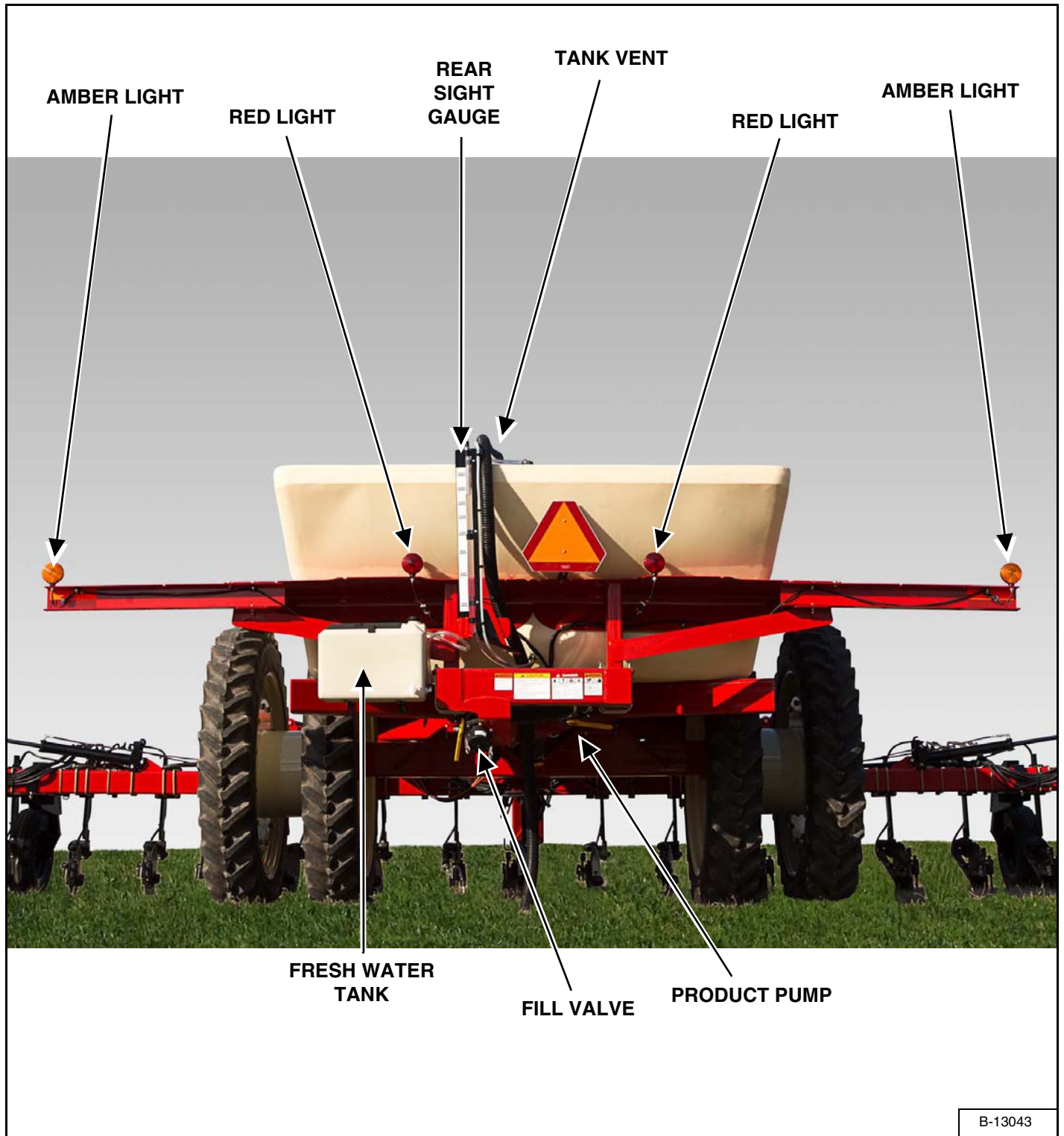

Farm King



SAFETY

SAFETY INSTRUCTIONS15
 Safe Operation Is The Operator’s Responsibility15
 Safe Operation Needs A Qualified Operator15
 Use Safety Rules16
 Transport Safety17
 Machine Requirements And Capabilities17

FIRE PREVENTION18
 Maintenance18
 Operation18
 Starting18
 Electrical18
 Hydraulic System18
 Fueling18
 Spark Arrester Exhaust System18
 Welding And Grinding19
 Fire Extinguishers19
 Rules For Safe Use Of Chemicals20

SAFETY SIGNS (DECALS)21

EQUIPMENT DECALS AND SIGNS24

SAFETY SIGN-OFF FORM25

Farm King



SAFETY INSTRUCTIONS

Safe Operation Is The Operator’s Responsibility

	<p>Safety Alert Symbol</p>
<p>This symbol with a warning statement means: “Warning, be alert! Your safety is involved!” Carefully read the message that follows.</p>	



CAUTION

The signal word **CAUTION** on the machine and in the manuals indicates a potentially hazardous situation which, if not avoided, may result in minor or moderate injury. It may also be used to alert against unsafe practices.



DANGER

The signal word **DANGER** on the machine and in the manuals indicates a hazardous situation which, if not avoided, will result in death or serious injury.



WARNING

The signal word **WARNING** on the machine and in the manuals indicates a potentially hazardous situation which, if not avoided, could result in death or serious injury.



IMPORTANT

This notice identifies procedures which must be followed to avoid damage to the machine.

Safe Operation Needs A Qualified Operator



WARNING

Operators must have instructions before operating the machine. Untrained operators can cause injury or death.

For an operator to be qualified, he or she must not use drugs or alcohol which impair alertness or coordination while working. An operator who is taking prescription drugs must get medical advice to determine if he or she can safely operate a machine and the equipment.

A Qualified Operator Must Do The Following:

Understand the Written Instructions, Rules and Regulations

- The written instructions from Farm King include the Warranty Registration, Dealer Inspection Report, Operator And Parts Manual and machine signs (decals).
- Check the rules and regulations at your location. The rules may include an employer’s work safety requirements. Regulations may apply to local driving requirements or use of a Slow Moving Vehicle (SMV) emblem. Regulations may identify a hazard such as a utility line.

Have Training with Actual Operation

- Operator training must consist of a demonstration and verbal instruction. This training is given by the machine owner prior to operation.
- The new operator must start in an area without bystanders and use all the controls until he or she can operate the machine safely under all conditions of the work area. Always fasten seat belt before operating.

Know the Work Conditions

- Clear working area of all bystanders, especially small children and all obstacles that might be hooked or snagged, causing injury or damage.
- Know the location of any overhead or underground power lines. Call local utilities and have all underground power lines marked prior to operation.
- Wear tight fitting clothing. Always wear safety glasses when doing maintenance or service.

Use Safety Rules

- Read and follow instructions in this manual and the tractor's Operators Manual before operating.
- Read chemical manufacturers warnings, instructions and Procedures before starting and follow them exactly.
- Under no circumstances should young children be allowed to work with this equipment.
- This equipment is dangerous to children and persons unfamiliar with its operation.
- If the elderly are assisting with work, their physical limitations need to be recognized and accommodated.
- Check for overhead and / or underground lines before operating equipment (if applicable).
- In addition to the design and configuration of equipment, hazard control and accident prevention are dependent upon the awareness, concern, prudence and proper training of personnel involved in the operation, transport, maintenance and storage of equipment.
- Check that the equipment is securely fastened to the tractor / towing vehicle.
- Make sure all the machine controls are in the NEUTRAL position before starting the machine.
- Operate the equipment only from the operator's position.
- Operate the equipment according to the Operator And Parts Manual.
- When learning to operate the equipment, do it at a slow rate in an area clear of bystanders, especially small children.
- DO NOT permit personnel to be in the work area when operating the equipment.
- The equipment must be used ONLY on approved tractors / transport vehicles.
- DO NOT modify the equipment in any way. Unauthorized modification may impair the function and / or safety and could affect the life of the equipment.
- Stop tractor engine, place all controls in neutral, set park brake, remove ignition key and wait for all moving parts to stop before servicing, adjusting, repairing, unplugging or filling.
- DO NOT make any adjustments or repairs on the equipment while the machine is running.
- Keep shields and guards in place. Replace if damaged.
- Keep hands, feet, hair and clothing away from all moving parts.

Transport Safety

- Do not exceed 20 mph (32 kph). Reduce speed on rough roads and surfaces.
- Comply with state and local laws governing highway safety and movement of machinery on public roads.
- The use of flashing amber lights is acceptable in most localities. However, some localities prohibit their use. Local laws should be checked for all highway lighting and marking requirements.
- Do not transport with fluid in the tank.
- Lower the toolbar onto the “Red” transport stops to reduce the overall height before transporting.
- Always install transport locks, pins or brackets before transporting.
- Always yield to oncoming traffic in all situations and move to the side of the road so any following traffic may pass.
- Always enter curves or drive up or down hills at a low speed and at a gradual steering angle.
- Never allow riders on either tractor or equipment.
- Keep tractor / towing vehicle in a lower gear at all times when traveling down steep grades.
- Maintain proper brake settings at all times (if equipped).

Machine Requirements And Capabilities

- Fasten seat belt securely. If equipped with a foldable Roll-Over Protective Structure (ROPS), only fasten seat belt when ROPS is up and locked. DO NOT wear seat belt if ROPS is down.
- Machine’s three-point hitch must be equipped with sway bars or chains.
- Stop the machine and engage the parking brake. Install blocks in front of and behind the rear tires of the machine. Install blocks underneath and support the equipment securely before working under raised equipment.
- Keep bystanders clear of moving parts and the work area. Keep children away.
- Use increased caution on slopes and near banks and ditches to prevent overturn.
- Make certain that the Slow Moving Vehicle (SMV) emblem is installed so that it is visible and legible. When transporting the equipment, use the flashing warning lights (if equipped) and follow all local regulations.
- Operate this equipment with a machine equipped with an approved Roll-Over Protective Structure (ROPS). Always wear seat belt when the ROPS is up. Serious injury or death could result from falling off the machine.
- Before leaving the operator’s position:
 1. Always park on a flat level surface.
 2. Place all controls in neutral.
 3. Engage the parking brake.
 4. Stop engine.
 5. Wait for all moving parts to stop.
- Carry passengers only in designated seating areas. Never allow riders on the machine or equipment. Falling off can result in serious injury or death.
- Start the equipment only when properly seated in the operator’s seat. Starting a machine in gear can result in serious injury or death.
- Operate the machine and equipment from the operator’s position only.
- The parking brake must be engaged before leaving the operator’s seat. Rollaway can occur because the transmission may not prevent machine movement.

FIRE PREVENTION



Maintenance

The machine and some equipment have components that are at high temperatures under normal operating conditions. The primary source of high temperatures is the engine and exhaust system. The electrical system, if damaged or incorrectly maintained, can be a source of arcs or sparks.

Flammable debris (leaves, straw, etc.) must be removed regularly. If flammable debris is allowed to accumulate, it can cause a fire hazard. Clean often to avoid this accumulation. Flammable debris in the engine compartment is a potential fire hazard.

The operator's area, engine compartment and engine cooling system must be inspected every day and cleaned if necessary to prevent fire hazards and overheating.

All fuels, most lubricants and some coolant mixtures are flammable. Flammable fluids that are leaking or spilled onto hot surfaces or onto electrical components can cause a fire.

Operation

The Farm King machine must be in good operating condition before use.

Check all of the items listed on the service schedule under the 8 hour column. (See "SERVICE SCHEDULE" on page 67.)

Do not use the machine where exhaust, arcs, sparks or hot components can contact flammable material, explosive dust or gases.

Starting

Do not use ether or starting fluids on any engine that has glow plugs. These starting aids can cause explosion and injure you or bystanders.

Use the procedure in the tractor's operator's manual for connecting the battery and for jump starting.

Electrical



Check all electrical wiring and connections for damage. Keep the battery terminals clean and tight. Repair or replace any damaged part or wires that are loose or frayed.

Battery gas can explode and cause serious injury. Do not jump start or charge a frozen or damaged battery. Keep any open flames or sparks away from batteries. Do not smoke in battery charging area.

Hydraulic System

Check hydraulic tubes, hoses and fittings for damage and leakage. Never use open flame or bare skin to check for leaks. Hydraulic tubes and hoses must be properly routed and have adequate support and secure clamps. Tighten or replace any parts that show leakage.

Always clean fluid spills. Do not use gasoline or diesel fuel for cleaning parts. Use commercial nonflammable solvents.

Fueling



Stop the engine and let it cool before adding fuel. No smoking! Do not refuel a machine near open flames or sparks. Fill the fuel tank outdoors.

Spark Arrester Exhaust System

The spark arrester exhaust system is designed to control the emission of hot particles from the engine and exhaust system, but the muffler and the exhaust gases are still hot.

Check the spark arrester exhaust system regularly to make sure it is maintained and working properly. Use the procedure in the machine's Operator And Parts Manual for cleaning the spark arrester muffler (if equipped).

Welding And Grinding

Always clean the machine and equipment, disconnect the battery, and disconnect the wiring from the machine controls before welding. Cover rubber hoses, battery and all other flammable parts. Keep a fire extinguisher near the machine when welding.

Have good ventilation when grinding or welding painted parts. Wear dust mask when grinding painted parts. Toxic dust or gas can be produced.

Dust generated from repairing nonmetallic parts such as hoods, fenders or covers can be flammable or explosive. Repair such components in a well ventilated area away from open flames or sparks.

Fire Extinguishers

Know where fire extinguishers and first aid kits are located and how to use them. Inspect the fire extinguisher and service the fire extinguisher regularly. Obey the recommendations on the instructions plate.

Rules For Safe Use Of Chemicals

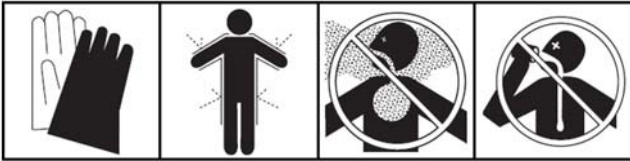

CHEMICAL HAZARD

To prevent serious injury or death:

WEAR PERSONAL PROTECTIVE EQUIPMENT

- Do not allow chemical or solution to touch skin. Some chemicals can be absorbed through the skin.
- Wear rubber gloves and protective gear at all times.

DON'T BREATHE VAPOR

- Avoid chemical splash and vapor. Keep others away.
- Do not breathe vapor.
- Wear proper respirator when working with chemicals.
- Chemicals can be toxic.

DON'T INGEST CHEMICAL

- If in eyes or mouth, read manufacturer's instructions and follow them exactly.
- Seek immediate medical attention.
- A poison control number is usually inside the front cover of your telephone book.

-
- Always read the label before using chemicals. Follow instructions from chemical manufacturer on how to select, use and handle each chemical. Note protection information each time before opening the container.
 - Verbal warnings must be given if written warnings cannot be understood by workers.

- Do not spill chemicals on skin or clothing. If chemicals are spilled, remove contaminated clothing immediately and wash skin (and clothing) thoroughly with soap and water. Wash hands and face with soap and water and change clothing after spraying. Wash clothing each day before reuse.
- The product tank and system should be emptied of chemical mixture and flushed with clean water before servicing the spray system or spray components. Clean machine of all chemical residue before servicing.
- Keep all chemical lines, fittings and couplers tight and free of leaks before starting and operating.
- Rinse the applicator off before leaving the fertilized field. Never contaminate the farmyard or drainage system with applicator rinse.
- Avoid inhaling chemicals. When directed on the label, wear protective clothing, face shield or goggles.
- Never smoke while applying or handling chemicals.
- Cover food and water containers when applying chemicals around livestock or pet areas.
- If symptoms of illness occurs during or shortly after chemical application, call a physician or go to a hospital immediately.
- Follow label directions and advise to keep residues on edible portions of plants within the limits permitted by law.
- Keep chemicals out of the reach of children, pets and unauthorized personnel. Store them outside of the home, away from food and feed and lock them in a secure area.
- Keep bystanders away from spray drift.
- Always store chemicals in original containers and keep them tightly closed. Never keep them in anything but the original container. Read labels for hazards about chemical reaction with certain types of metals.
- Always dispose of empty containers according to manufacturer's directions.

SAFETY SIGNS (DECALS)

Follow the instructions on all the signs (decals) that are on the equipment. Replace any damaged signs (decals) and be sure they are in the correct locations. Equipment signs are available from your Farm King equipment dealer.

Front Left Side Of Hitch

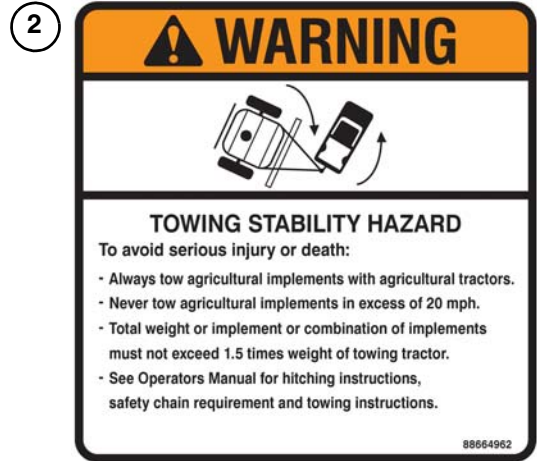

p/n 88664962



p/n 88665017



p/n 88664936



p/n 88664875

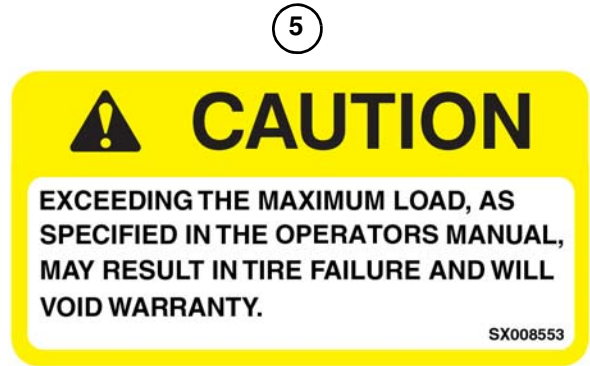

p/n SX008553

Rear Of Chassis Frame (Rear Of Machine)



Pivot Points On Outer Wings (Front and Back)



1



p/n 88665016

2



p/n 88664875

1



p/n SX002439

3



p/n 88665018

4



p/n 88664936

Pivot Points On Inner Wings (Front and Back)



1



p/n SX002439

2



p/n 88663026

EQUIPMENT DECALS AND SIGNS

NOTE: All safety related decals are shown in the Safety Signs Section. (See "SAFETY SIGNS (DECALS)" on page 21.)

Check and replace any worn, torn, hard to read or missing decals on your equipment.

Part Number 88670177

1840

Part Number 910601

Farm King

Part Number SX17-5910 (Amber)



Part Number SX17-5915 (Red)



Part Number SX17-5920 (Day Orange)



Part Number SXJD5403



Part Number 88670094

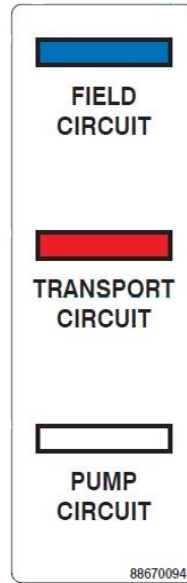

Part Number 88665331

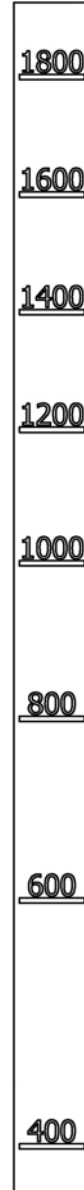

Farm King



ASSEMBLY

COMPONENT INSTALLATION29

- Preparing For Assembly29
- Coulter Installation32
- Gauge Wheel Installation33
- Supply Hose Installation33
- Coulter Injector Alignment34
- Coulter Knife Alignment34
- Orifice Installation (Coulters / Knives)35
- Tip Installation (Coulters / Injectors)35
- Slow Moving Vehicle Sign Installation36
- Spray Controller Console Installation36
- Shipping Adapter Removal (Dual Tires Only)36

Farm King



COMPONENT INSTALLATION

Preparing For Assembly



1840 fertilizer applicators are shipped without some components installed due to transporting height and width restrictions.

- Using the packing list, locate and count the individual components and verify that you have received the correct number of each component.
- Check all the components for damage. If any components are damaged or missing, contact your Farm King dealer.



AVOID INJURY OR DEATH

Before moving the tractor, look in all directions and make sure no bystanders, especially small children are in the work area. Do not allow anyone between the tractor and the equipment when backing up to the equipment for connecting.

Connect the fertilizer applicator to the tractor. (See “Connecting The Fertilizer Applicator To The Tractor” on page 42.)

Move the tractor, fertilizer applicator and coulters to an area large enough that will allow the toolbar and wings to be fully extended and sufficient clearance for forklift access.



AVOID INJURY OR DEATH

Before you leave the operator’s position:

- Always park on a flat level surface.
- Place all controls in NEUTRAL.
- Engage the park brake.
- Stop the engine and remove the key.
- Wait for all moving parts to stop.

Park the tractor / equipment on a flat level surface.

Place all controls in neutral, engage the park brake, stop the engine and wait for all moving parts to stop. Leave the operator’s position.



AVOID INJURY OR DEATH

Wear safety glasses to prevent eye injury when any of the following conditions exist:

- When fluids are under pressure.
- Flying debris or loose material is present.
- Engine is running.
- Tools are being used.

⚠ WARNING



HIGH PRESSURE FLUID HAZARD

To prevent serious injury or death from high pressure fluid:

- Relieve pressure on system before repairing or adjusting.
- Wear proper hand and eye protection when searching for leaks. Use wood or cardboard instead of hands.
- Keep all components in good repair.

! IMPORTANT

- Contain and dispose of any oil leakage in an environmentally safe manner.
- Thoroughly clean the quick couplers before making connections. Dirt can quickly damage the system.

NOTE: Make sure the quick couplers are fully engaged. If the quick couplers do not fully engage, check to see that the couplers are the same size and type.

NOTE: Hydraulic hoses marked with two colored markers (tape) is the pressure line. Hydraulic hoses marked with single colored marker (tape) is the return line.

Figure 3

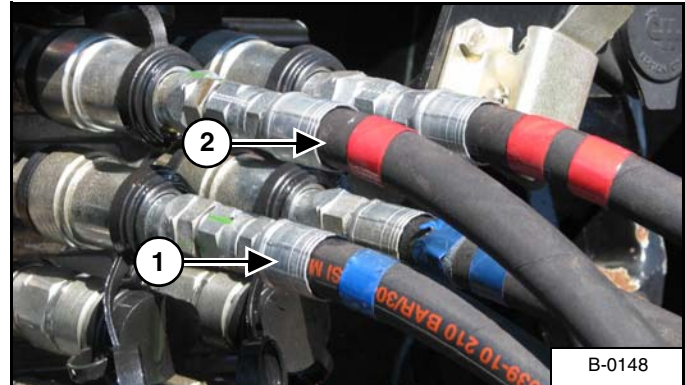

Connect the Blue (Work Circuit) and Red (Transport Circuit) marked hydraulic hoses (Items 1 & 2) [Figure 3].

NOTE: Do not connect the hydraulic hoses with White markings (Ace Pump). Doing so could result in damage to the components.

Figure 4

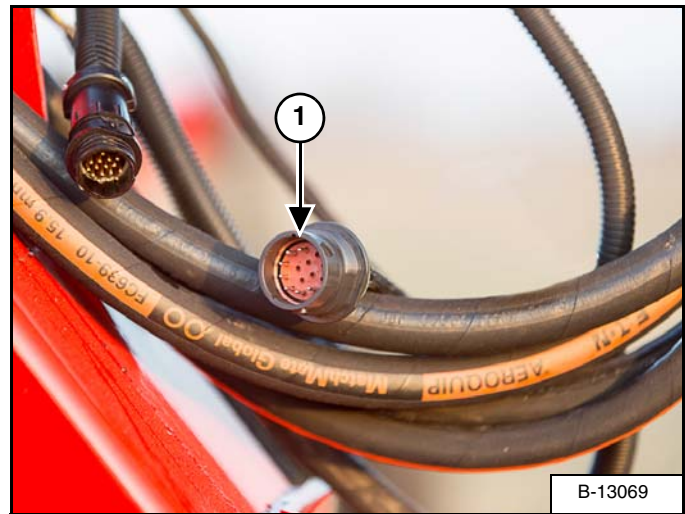

Connect the circuit switch (Item 1) [Figure 4] and implement harness.

Connect the 7 Pin electrical harness.

Figure 5



Press the circuit switch to (Item 1) “work” [Figure 5].

Using the work circuit, lift the toolbar and remove the “Red” cylinder stop. Then press the circuit switch to transport and unfold the wings using the transport circuit before lowering the toolbar.

Press the circuit switch to lower the toolbar with the “Work Circuit” (hydraulic hoses with the “Blue” markers), until the center coulters are nearly contacting the ground.

Place all controls in neutral, engage the park brake, stop the engine and wait for all moving parts to stop. Leave the operator’s position. (See “Entering And Leaving The Operator’s Position” on page 41.)

Figure 6

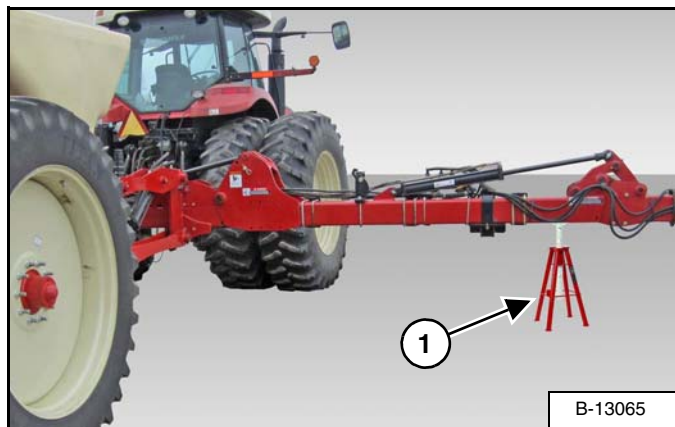

Place jack stands (Item 1) [Figure 6] under the wing(s) frame to support the wing(s) during assembly (both sides).

NOTE: Always use jack stands that are in good condition and of adequate size to support the fertilizer applicator wing(s).

NOTE: Verify that the jack stands are adjusted high enough to support the wing(s) and keep the installed coulters above the ground to prevent coulters damage.

Move to the operator’s seat and start the engine. (See “Entering And Leaving The Operator’s Position” on page 41.)

Engage the tractor hydraulics. (See the tractor’s operator’s manual for the correct procedure.)

Lower toolbar onto the jack stands.

Figure 7

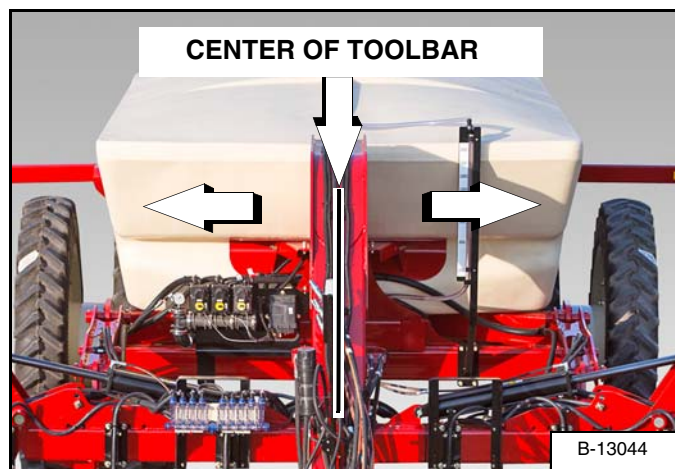

Locate the center of the toolbar. Measure out from the center of the toolbar and place a mark at the desired spacing (38”, 30”, 22”, 20”) [Figure 7].

! IMPORTANT

When installing the coulters and gauge wheels, the toolbar and wings must be level and supported.

Coulter Installation

! IMPORTANT

Coulter installation may require two people.

Figure 8

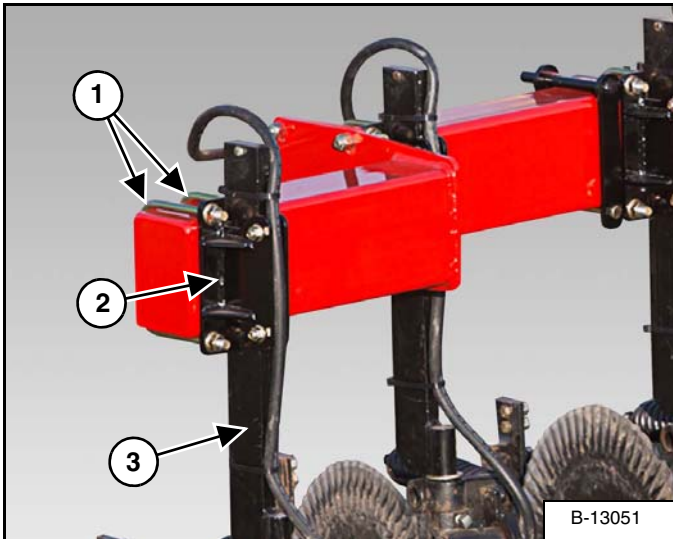

Install two u-bolts (Item 1) [Figure 8] over the toolbar (back to front) at each marked location (38", 30", 22", 20") on the toolbar.

Align clamp plates (Item 2) [Figure 8] with the u-bolts. Install lock nuts onto the u-bolts. Tighten lock nuts.

Slide the shaft (Item 3) [Figure 8] of the coulter assembly up through the clamp plates and secure. Tighten all hardware.

Continue to install clamp plate / coulter assemblies along the toolbar at the desired spacing (38", 30", 22", 20").

Gauge Wheel Installation

NOTE: Install the gauge wheels on the inward side and up against the last coulter assembly on the inner wing (both sides).

Figure 9

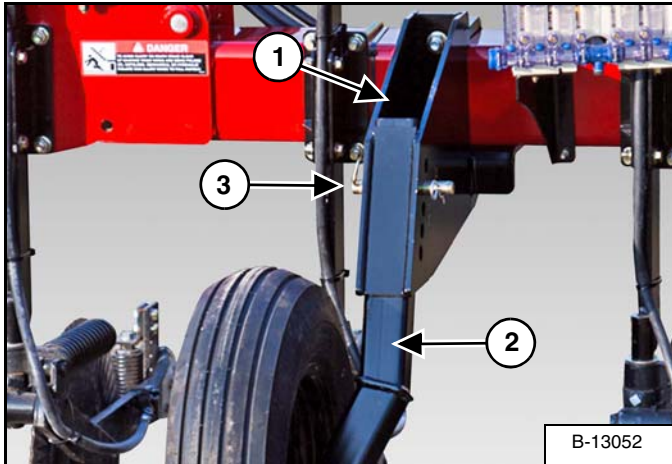

Install mounting bracket (Item 1) [Figure 9] to the inner wing. Position the mounting bracket so the gauge wheel is located directly in front of the last coulter assembly on the inner wing.

Slide the gauge wheel (Item 2) [Figure 9] into the gauge wheel mount to the desired height and install the hitch pin (Item 3) and retaining pin.

Install the other gauge wheel on the opposite inner wing.

Supply Hose Installation



Review the supply line routing on the installed coulters or main toolbar before attaching lines to inner wing coulters.

Figure 10

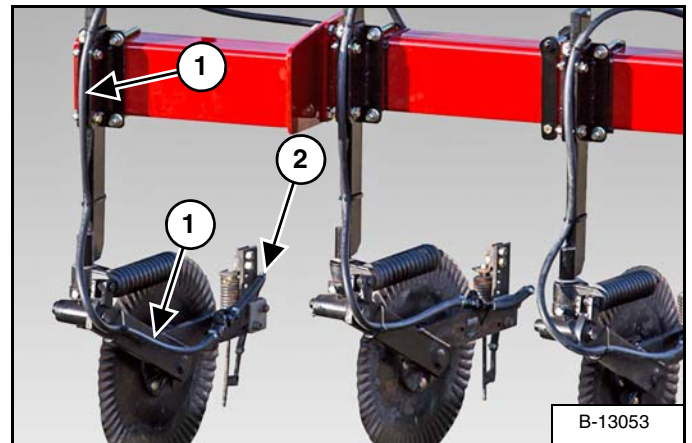

Route the supply hose (Item 1) [Figure 10] down the shaft of the coulter assembly and to the knife / injector. Secure with cable ties.

Apply petroleum jelly to fittings and install hose onto the 90° hose barb fitting (Item 2) [Figure 10] and secure in place with hose clamp.

Coulter Injector Alignment

Figure 11

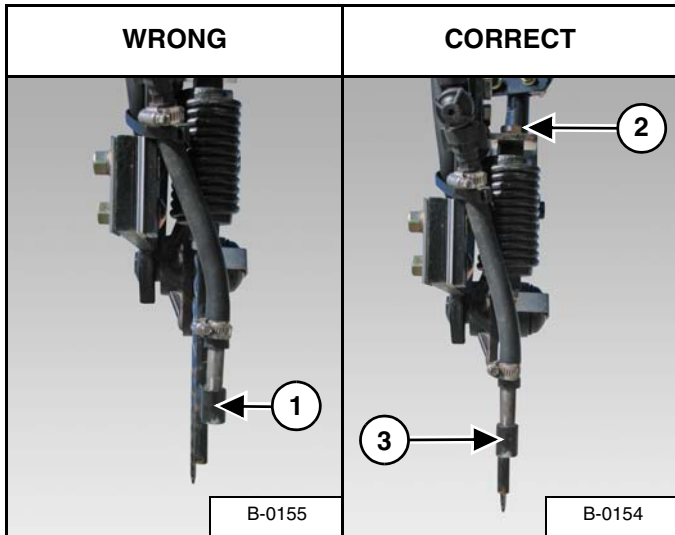

Injector (Item 1) [Figure 11] is not aligned with coulter.

Loosen bolt (Item 2) [Figure 11] and align the injector with coulter blade. Tighten bolt.

Injector (Item 3) [Figure 11] aligned with coulter blade.

Coulter Knife Alignment

Figure 12

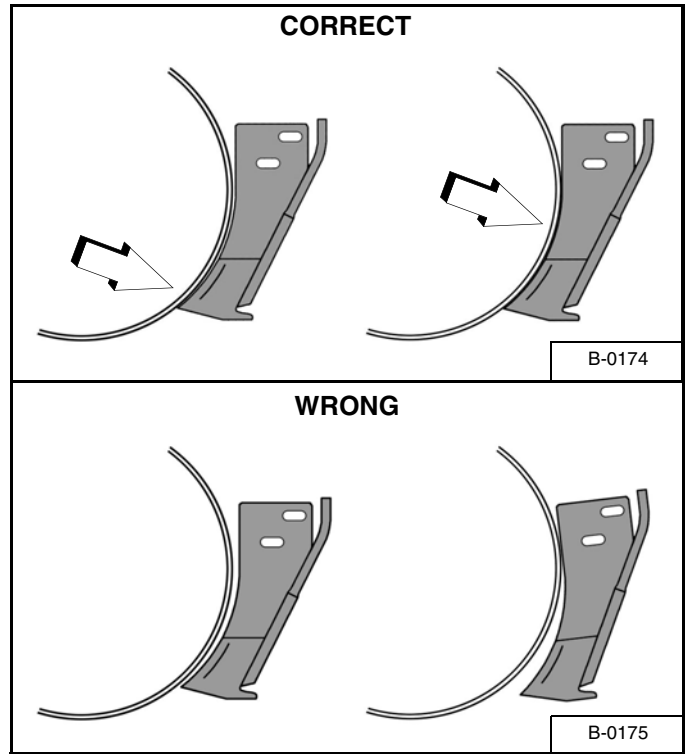

Knives should rub slightly on blade at bottom of knife (CORRECT) [Figure 12].

Figure 13

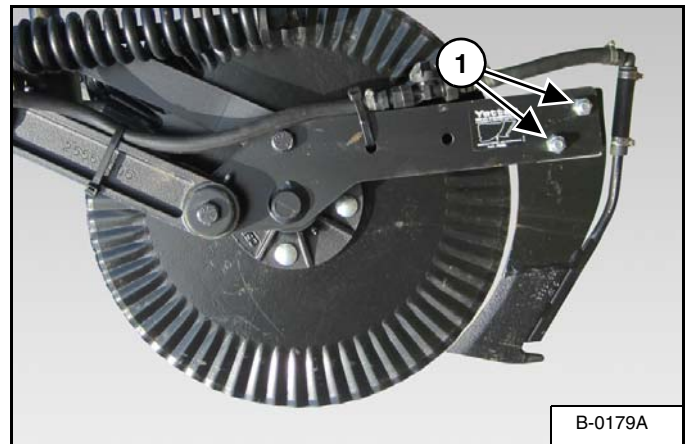

Loosen the two bolts (Item 1) [Figure 13] and adjust knife to rub slightly on blade. Tighten bolts.

Orifice Installation (Coulters / Knives)

Figure 14

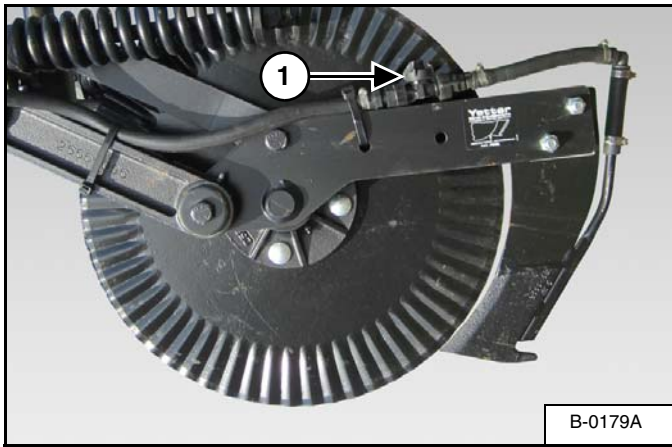

Loosen hose fitting by 1/4 turn (Item 1) [Figure 14] and disconnect.

Install orifice between hose fitting and diaphragm check valve, for the desired application rate and travel speed.

Connect and tighten hose fitting by 1/4 turn back on to the check valve.

Tip Installation (Coulters / Injectors)

Figure 15

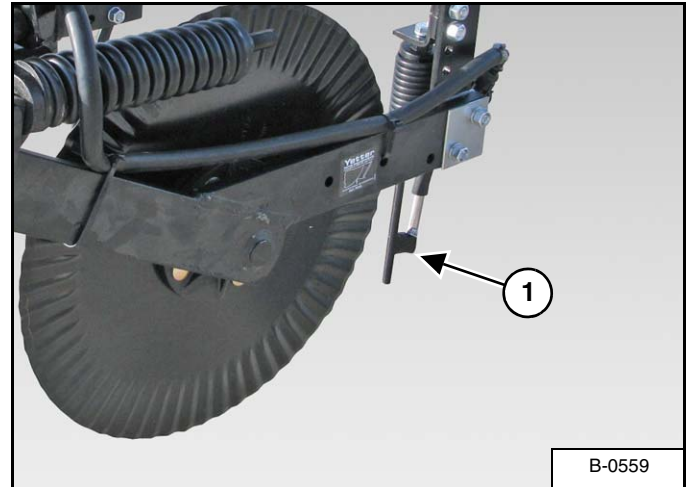

Install spray tip, I.E. TeeJet StreamJet tip into female threads located at the bottom of the assembly (Item 1) [Figure 15].

Slow Moving Vehicle Sign Installation

Figure 16

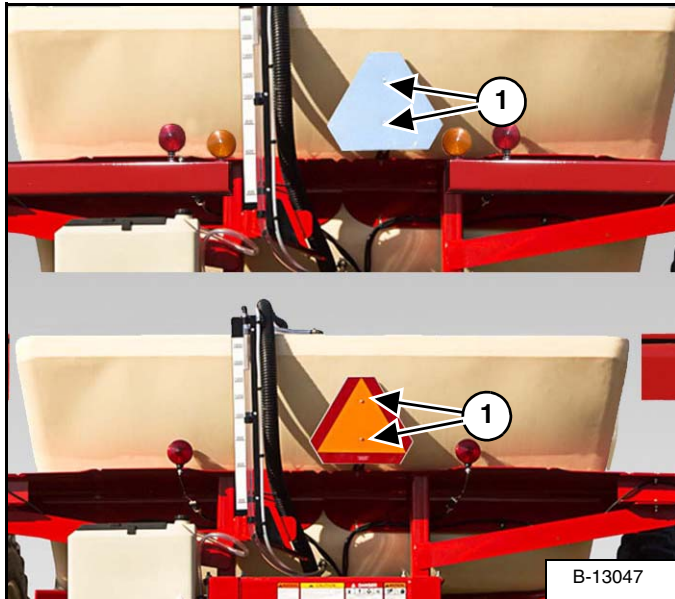

Remove the two bolts (Item 1) [Figure 16] and slow moving vehicle sign.

Rotate the slow moving vehicle sign 180°, align mounting holes and install bolts to secure the slow moving vehicle sign in the operation position.

Spray Controller Console Installation

Install the spray controller console in the cab of the tractor according to the manufacturers specifications. (See the spray controller Installation and Operator’s manual for the correct procedure.)

Review the spray controller operator’s manual provided with fertilizer applicator for calibration and operating instructions before operating the fertilizer applicator.

Mount speed transducer to unit. Connect input to controller and calibrate.

Calibrate the system for the speed and rate desired. (See the spray controller Operator’s manual for the correct procedure.)

(See “NOZZLE SELECTION” on page 210.) and (See “NOZZLE SPECIFICATIONS” on page 211.) for additional information.

Shipping Adapter Removal (Dual Tires Only)

Figure 17

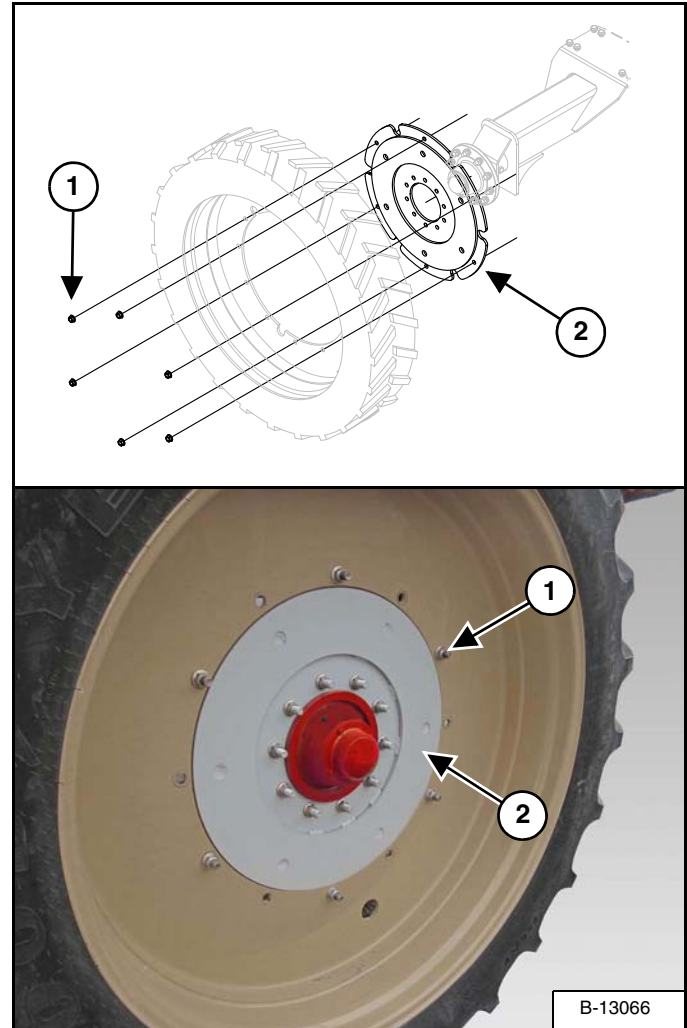

Remove the six 3/4-16 Grade 8 lock nuts (Item 1) [Figure 17].

Remove shipping adapter (Item 2) [Figure 17].

Install correct, inside and outside dual tires.

Torque to 360 ft-lbs.

OPERATION

GENERAL INFORMATION	39
Pre - Operation Checklist	39
Break - In Checklist	40
Tractor Requirements	41
Entering And Leaving The Operator's Position	41
INITIAL SET-UP	42
Connecting The Fertilizer Applicator To The Tractor	42
Connecting Hydraulic Hoses	43
Connecting Electrical Harness	44
Connecting Circuit Switch Harness	44
FERTILIZER APPLICATOR OPERATION	45
Leveling The Fertilizer Applicator	45
HYDRAULIC FUNCTIONS	47
Transport Position	47
Transport Position	48
Hydraulic Cylinder Functions	49
Setting Hydraulic Proximity Switches	50
Filling The Product Tank	51
Filling Fresh Water Tank	53
FIELD OPERATION	53
Pre-Operation	53
Centrifugal Pump (Option)	54
JOHN BLUE PUMP SETTING	55
John Blue Twin Piston Pump Test (Option)	56
Centrifugal Pump / Controller System Test	57
Operating The Fertilizer Applicator	59
Operating Guidelines	60
TRANSPORTING	60
Requirements	60
Transporting Guidelines	61

Farm King



GENERAL INFORMATION

Pre - Operation Checklist

Before operating the fertilizer applicator for the first time and each time thereafter, check the following items:



AVOID INJURY OR DEATH

Wear safety glasses to prevent eye injury when any of the following conditions exist:

- **When fluids are under pressure.**
- **Flying debris or loose material is present.**
- **Engine is running.**
- **Tools are being used.**

-
1. Lubricate the equipment per the schedule outline in the Maintenance Section. (See "SERVICE SCHEDULE" on page 67.)
 2. Check the fertilizer applicator hitch for damaged, loose or missing parts. Repair as needed before operation.
 3. Check the condition of the coulters and gauge wheels.
 4. Check condition of all chemical / fertilizer components for pinching, crimps or leaks. Re-align as required. Tighten fittings to correct leaks or replace components. Straighten lines to eliminate pinching or crimps.

NOTE: Do not operate with leaks.

5. Make sure that all guards and shields are in place, secured and functioning as designed.



Leaking fluids under pressure can enter the skin and cause serious injury or death. Immediate medical attention is required. Wear goggles. Use cardboard to check for leaks.

-
6. Check condition of all hydraulic components for leaks. Repair as required.

NOTE: Do not operate with hydraulic leaks.

7. Check that all electrical connections are tight.
8. Check and tighten all lug nuts to 420 ft.-lb. torque.
9. Check tire pressure. Inflate per manufacturer's specification.

Break - In Checklist

Check and tighten all lug nuts to their specified torque (420 ft.-lb.) after transporting for five (5) miles (11km).

Check the following mechanical items after 1 hour of operation and again after 10 hours of operation:

1. Check that all electrical connections are tight.

Figure 18

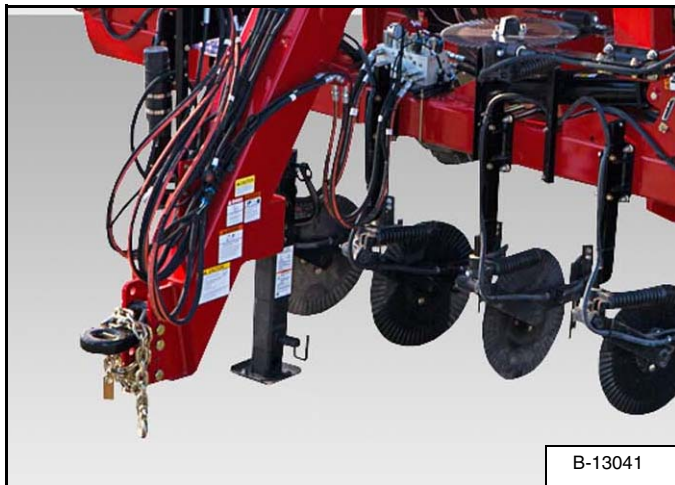

2. Check the fertilizer applicator hitch for damaged, loose or missing parts **[Figure 18]**. Repair as needed before operation.
3. Check condition of all hydraulic components for leaks. Repair as required.

4. Check condition of all chemical / fertilizer components for pinching, crimps or leaks. Re-align as required. Tighten fittings to correct leaks or replace components. Straighten lines to eliminate pinching or crimps.
5. Check for loose fasteners and hardware. Tighten as required.
6. Check lug nuts for tightness. Tighten to 420 ft.-lb. torque.
7. Clean screen of in-line strainer.
8. Check the coulters and gauge wheels. Remove any twine, wire or other material that has become entangled.
9. Check condition of all hydraulic components for leaks. Tighten fittings to correct leaks or replace components. Do not operate with hydraulic leaks.
10. Check tire pressure. Inflate per manufacturer's specification.

Tractor Requirements

The 1840 Fertilizer Applicator requires a MFWD (Mechanical Front Wheel Drive) tractor, three auxiliary hydraulic functions, category IV rated drawbar and a 7-pin electrical connection.



Operate only on a pressure compensated, load sensing or flow compensated closed center hydraulic system. Use of tractor with an open center hydraulic system will result in the hydraulic flow continuously bypassing the relief valve. This will overheat the oil very quickly.



Some older model tractors may have a detented valve that will kick out when system pressure is achieved. This valve must be over-ridden. The valve must remain in detented position during field operations. Maintaining pressure will allow the system to keep the applicator functioning as desired.

Entering And Leaving The Operator’s Position

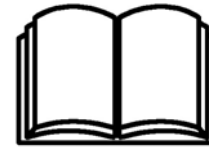

Follow the instructions in your tractor’s operation manual for the correct procedure.

Entering The Operator’s Position

Move to the operator’s position, start the engine and release the parking brake.

Leaving The Operator’s Position



AVOID INJURY OR DEATH

Before you leave the operator’s position:

- **Always park on a flat level surface.**
- **Place all controls in NEUTRAL.**
- **Engage the park brake.**
- **Stop the engine and remove the key.**
- **Wait for all moving parts to stop.**

Park the tractor / equipment on a flat level surface.

Place all controls in neutral, engage the park brake, stop the engine and wait for all moving parts to stop before leaving the operator’s position.

INITIAL SET-UP

Connecting The Fertilizer Applicator To The Tractor

Always inspect the tractor’s drawbar and fertilizer applicator hitch before connecting. See the tractor’s owner’s manual.

Enter the operator’s position. (See “Entering The Operator’s Position” on page 41.)

Move the tractor into position in front of the fertilizer applicator.



AVOID INJURY OR DEATH

Before moving the tractor, look in all directions and make sure no bystanders, especially small children are in the work area. Do not allow anyone between the tractor and the equipment when backing up to the equipment for connecting.

Move the tractor backwards, aligning the drawbar with the fertilizer applicator hitch.

NOTE: The jack may need to be lowered or raised for proper alignment of the drawbar and hitch.

If the fertilizer applicator hitch needs to be adjusted, stop the tractor when drawbar is just in front of the fertilizer applicator hitch.

Leave the operator’s position. (See “Leaving The Operator’s Position” on page 41.)

Figure 19

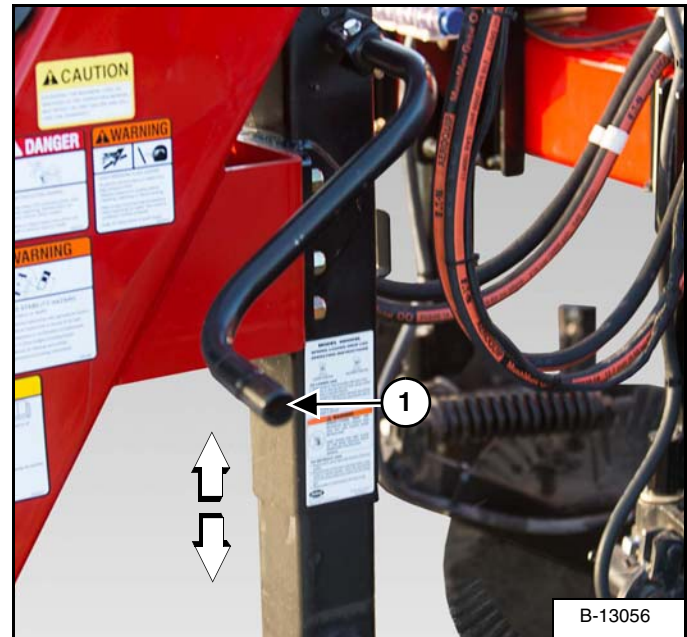

Turn the jack handle (Item 1) [Figure 19] clockwise to raise the hitch or counterclockwise to lower the hitch.

Lower or raise the fertilizer applicator hitch until aligned with the tractor’s drawbar.

Move to the operator’s seat, start the engine and release the parking brake.

Move the tractor backwards, aligning the drawbar hitch pin hole with the fertilizer applicator hitch pin hole(s).

Stop the tractor and leave operator’s position.



AVOID INJURY OR DEATH

Keep fingers and hands out of pinch points when connecting and disconnecting equipment.

NOTE: Always use a hitch pin of adequate size and strength and a retaining pin with a locking device.

Figure 20

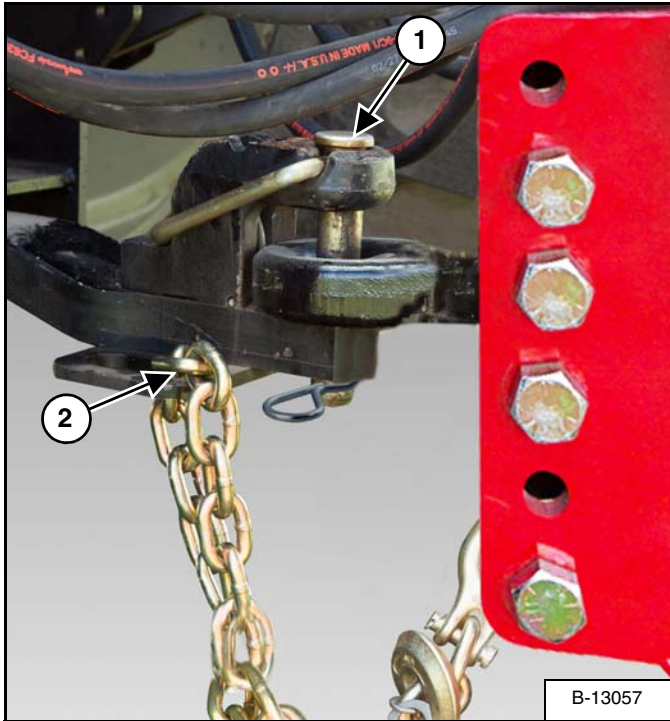

Install the hitch pin (Item 1) [Figure 20] and retaining pin to securely fasten the fertilizer applicator hitch to the tractor drawbar.

Attach the safety chain (Item 2) [Figure 20] around the drawbar.

Connecting Hydraulic Hoses



HIGH PRESSURE FLUID HAZARD

To prevent serious injury or death from high pressure fluid:

- Relieve pressure on system before repairing or adjusting.
- Wear proper hand and eye protection when searching for leaks. Use wood or cardboard instead of hands.
- Keep all components in good repair.



- Contain and dispose of any oil leakage in an environmentally safe manner.
- Thoroughly clean the quick couplers before making connections. Dirt can quickly damage the system.

NOTE: Make sure the quick couplers are fully engaged. If the quick couplers do not fully engage, check to see that the couplers are the same size and type.

NOTE: Hydraulic hoses marked with two colored markers (tape) is the pressure line. Hydraulic hoses marked with a single marker (tape) is the return line.

! IMPORTANT

The tractor's hydraulic flow to the Transport and Work Circuits (hydraulic hoses marked with Red and Blue tape) will need to be reduced to approximately 6 - 8 gpm (23 - 30 l) to prevent exceeding system specifications, erratic hydraulic functionality and possible component failure.

To Connect:

Figure 21

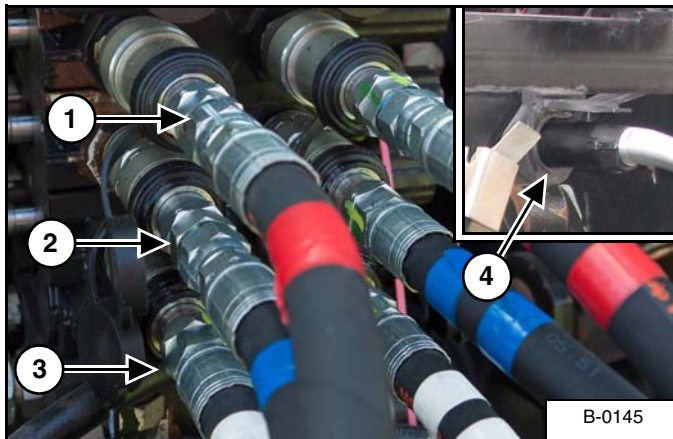

Push coupler into female coupler on the tractor until they are fully engaged and locked [Figure 21].

1. Transport Circuit (Red Tape): Wing Fold / Unfold (Item 1).
2. Work Circuit (Blue Tape): Toolbar Raise / Lower (Item 2).
3. Pump Circuit (White Tape): Liquid Product Pump (Item 3) (Connect the pump return line (one wrap of white tape) to the case drain port, if tractor is so equipped.).

To Disconnect:

! WARNING

AVOID BURNS

Hydraulic fluid, tubes, fittings and quick couplers can get hot when running equipment. Be careful when connecting and disconnecting quick couplers.

Release pressure and pull the male coupler out to disconnect.

Connecting Electrical Harness

Connect the fertilizer applicator's 7 pin electrical harness (Item 4) [Figure 21] to the tractor's electrical system.

Lower jack until weight of equipment is resting on tractor drawbar. Raise the foot of the jack to the highest possible storage position, prior to operation.

NOTE: Jack needs to be raised, stowed, and fully retracted for field operations

Connecting Circuit Switch Harness

Figure 22

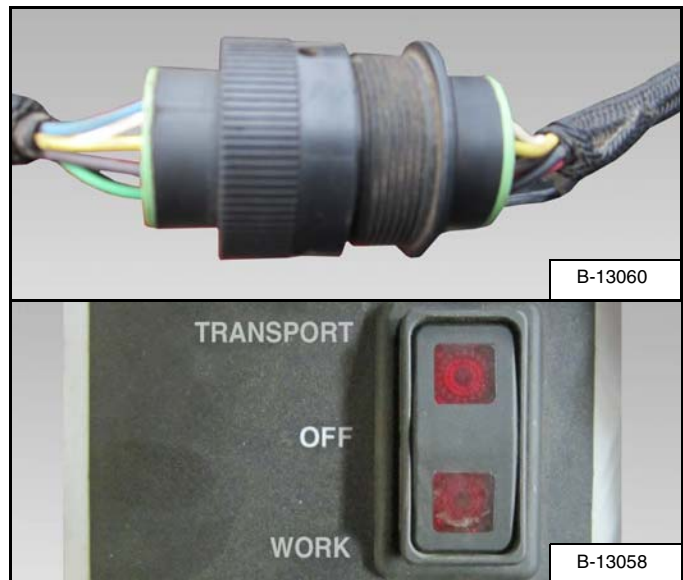

Connect the circuit switch harness [Figure 22] near the hitch.

The circuit switch is required to operate the hydraulic transport and work circuits properly.

FERTILIZER APPLICATOR OPERATION

Leveling The Fertilizer Applicator



The fertilizer applicator frame must be adjusted down or up until the fertilizer applicator is parallel with the ground prior to operation.

Lower the toolbar.

NOTE: The wings and toolbar should be in the operating position before leveling the fertilizer applicator frame.

Figure 23

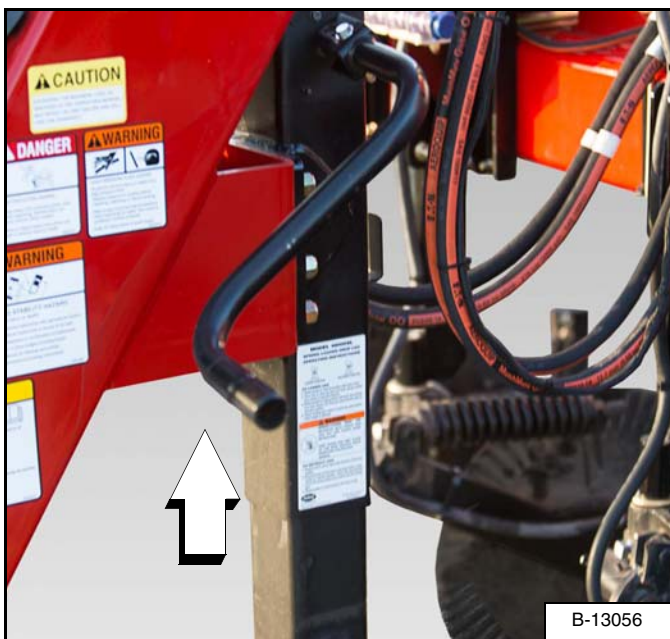

With the fertilizer applicator attached to the tractor, lower the jack from the transport position.

Raise the jack until the weight of the fertilizer applicator is on the jack. This will allow the clevis mounting bolts to be loosened and moved for leveling [Figure 23] (if required).

Figure 24

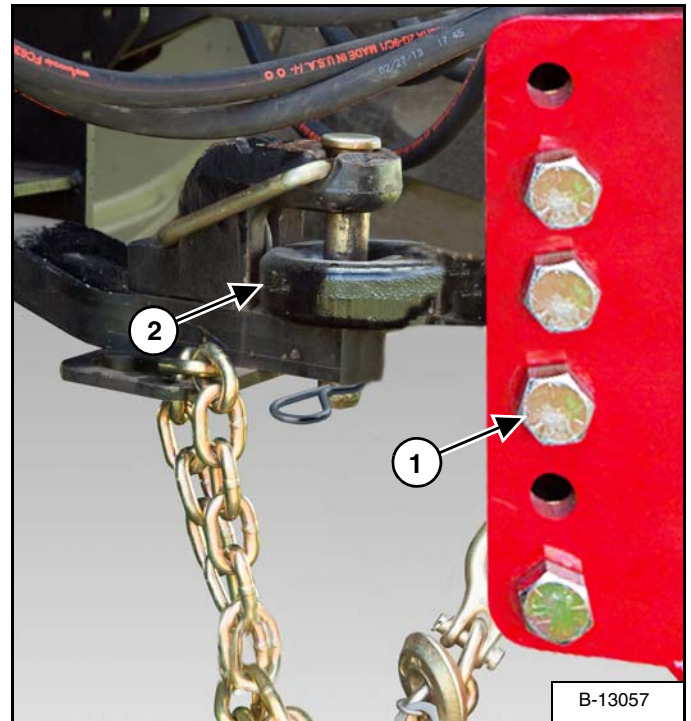

Loosen the three pintle hitch mounting bolts (Item 1) [Figure 24].

Figure 25

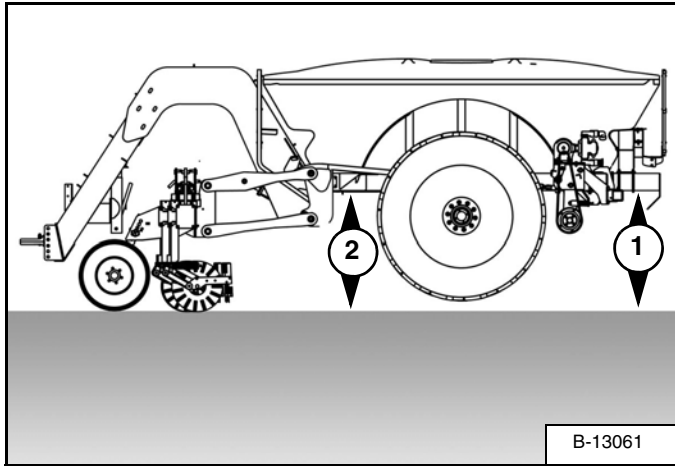

Measure the distance (Items 1 & 2) [Figure 25] from the ground to the bottom of the fertilizer applicator frame in the two locations shown.

NOTE: The two measurements should be approximately the same when the frame is level.

Raise or lower the jack until the fertilizer applicator frame is parallel with the ground. Raise or lower the pintle hitch (Item 2) [Figure 24] and align the closest mounting holes with frame. Install the three bolts.

Tighten the three pintle hitch mounting bolts and raise the jack into the storage position.

HYDRAULIC FUNCTIONS

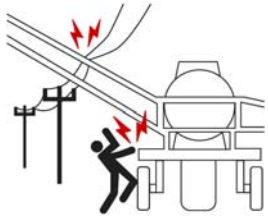

ELECTROCUTION HAZARD

To prevent serious injury or death from electrocution:

- Be aware of overhead powerlines.
- Keep away from powerlines when transporting or folding or unfolding wings.
- Electrocution can occur without direct contact.



To avoid serious injury or death, keep everyone clear of machine when folding or extending wings.



AVOID INJURY OR DEATH

Before operating the fertilizer applicator, look in all directions and make sure no bystanders, especially small children are in the work area.

Transport Position

Toggle the circuit switch in tractor cab to the Transport Circuit position. Set hydraulic flow to 6 - 8 gpm.

To Unfold:

- Raise the toolbar off of the “Red” cylinder stops.
- Remove the “Red” cylinder stops and place in the storage location.
- Remove the wing lock pins and place in storage location.
- Activate hydraulic circuit connected to the Transport Circuit (Red taped hoses).
- Inner Wings will unfold until the wing is level with the center section, as indicated by the respective proximity switch.
- Next, the outer wings will unfold until the cylinders are fully extended.

To Fold:

- Perform the reverse of the above procedure.

Transport Position



PREVENT COULTER DAMAGE

Always fully raise the toolbar before turning the tractor and fertilizer applicator and when moving the tractor and fertilizer applicator to starting point in the field.

Toggle the circuit switch in tractor cab to the Work Circuit position. Set hydraulic flow to 6 - 8 gpm.

Lowering Toolbar:

- Activate hydraulic circuit connected to Work Circuit (Blue taped hoses).
- While moving forward at a minimum speed of 3 mph, lower the toolbar to application height.
- Work circuit is required to be in detent position to provide down pressure to inner wing cylinders during the application pass.

Raising Toolbar:

- Perform the reverse of the above procedure.
- Wings will raise up to 15° above level as determined by the proximity switch setting.
- Inner Wing cylinders will raise as much as 15 degrees (proximity switch must be positioned).

Hydraulic Cylinder Functions

Use the following table to check the tractor valve function against the cylinder behavior. The hydraulic flow to the Transport and Work Circuits should not exceed 8 gpm. The system pressure required is 2000 psi minimum.

DIRECTIONAL VALVE	DIRECTIONAL VALVE CONFIGURATION	TOOLBAR ACTION	CYLINDER ACTION		
			TOOLBAR LIFT CYLINDERS	INNER WING CYLINDERS	OUTER WING CYLINDERS
Transport Circuit (hoses w/Red tape)	Spring Centered	Fold Up For Transport	Extend	Retract	Retract
	Spring Centered	Unfold For Operation	No Movement	Extend, Stops When Wings Are Level With Center	Extend
Work Circuit (hoses w/Blue tape)	Spring Centered	Lift For End Row Turn	Extend	Retract, Stops When Wing Raises 15°	No Movement
	Detent (Must Be In Constant Flow During Field Operation)	Down Pressure During Field Operation	Retract	Extend	Extend



1. Operate only on a pressure compensated, load sensing, or flow compensated closed center pump system. Use of an open center tractor hydraulic system will result in the hydraulic flow continuously bypassing through the relief valve resulting in an increase engine horsepower requirement to turn the pump at the relief valve pressure. This will overheat the oil and the tractor very quickly.
2. It is important to note that some older tractors will have a detented valve that will kick out when system pressure is achieved. This valve must be over-ridden. The valve must remain in detented position during field operations. Maintaining pressure will allow the system to keep the toolbar at a constant depth.

Setting Hydraulic Proximity Switches

Figure 26

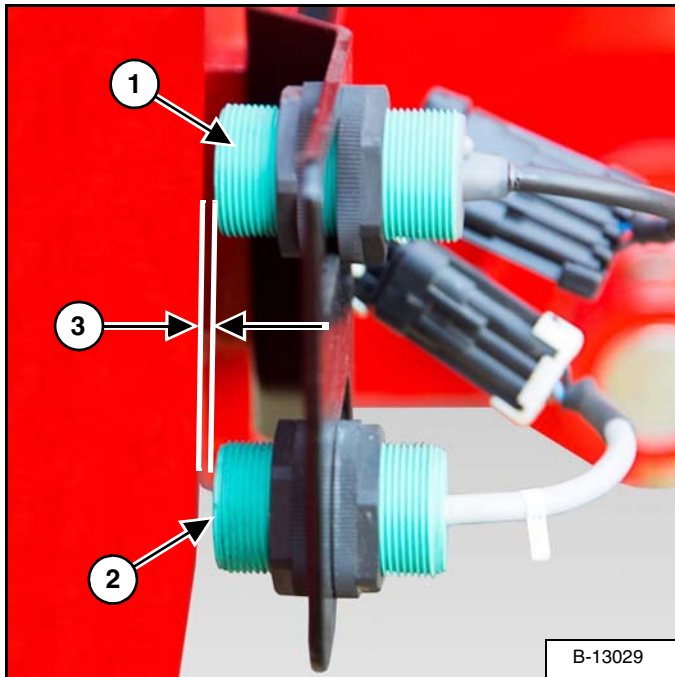

The proximity switches (Items 1 & 2) should be set at 1/4" to 3/8" from the steel frame (Item 3) [Figure 26] to be sensed.

Figure 27

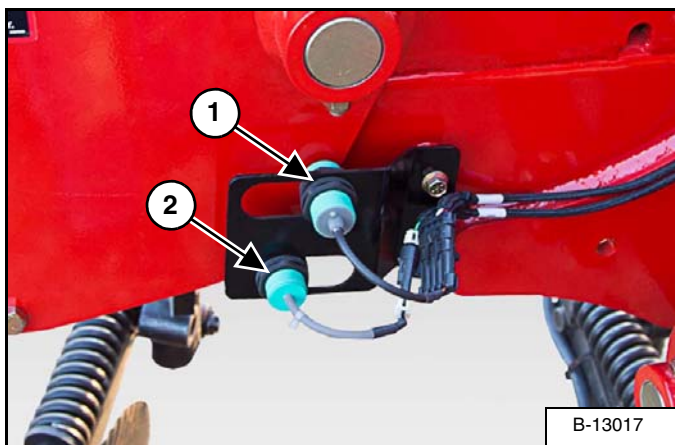

Switch #1 (Item 1) [Figure 27] should be positioned to stop the inner wing when level with the center section, during the unfold process only.

Switch #2 (Item 2) [Figure 27] should be positioned to stop the wing tilt at approx. 15° above level, for additional ground clearance on turn rows.

Filling The Product Tank



CHEMICAL HAZARD

To prevent serious injury or death:

WEAR PERSONAL PROTECTIVE EQUIPMENT

- Do not allow chemical or solution to touch skin. Some chemicals can be absorbed through the skin.
- Wear rubber gloves and protective gear at all times.

DON'T BREATHE VAPOR

- Avoid chemical splash and vapor. Keep others away.
- Do not breathe vapor.
- Wear proper respirator when working with chemicals.
- Chemicals can be toxic.

DON'T INGEST CHEMICAL

- If in eyes or mouth, read manufacturer's instructions and follow them exactly.
- Seek immediate medical attention.
- A poison control number is usually inside the front cover of your telephone book.



Do not spill chemicals on skin or clothing. If chemicals are spilled, remove contaminated clothing immediately and wash skin (and clothing) thoroughly with soap and water. Wash hands and face with soap and water and change clothing after spraying.



Always read the label before using chemicals. Follow the instructions from the chemical manufacturer on how to select, use and handle each chemical. Note protection information each time before opening the container.

Park the tractor / equipment on a flat level surface.

Place all controls in neutral, engage the park brake, stop the engine and wait for all moving parts to stop. Leave the operator's position. (See "Entering And Leaving The Operator's Position" on page 41.)



Add chemical solution to the product tank according to the manufacturer's recommendations.



Some items have been partially disassembled and/or removed to prevent damage to the tank, pump, and other components caused by freezing temperatures. Please install/assemble prior to first use.

Figure 28

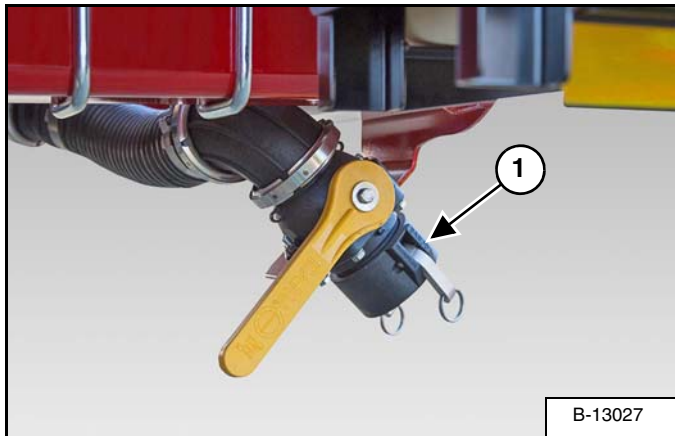

Remove fill cap (Item 1) [Figure 28].

Figure 29

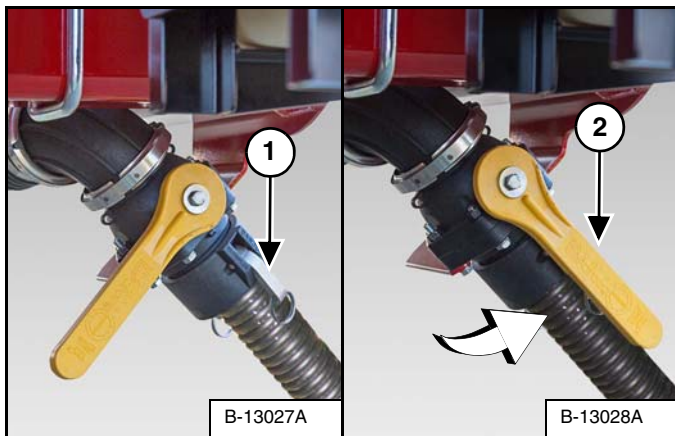

Install the fill hose (Item 1) [Figure 29].

Open fill valve (Item 2) [Figure 29].

Figure 30

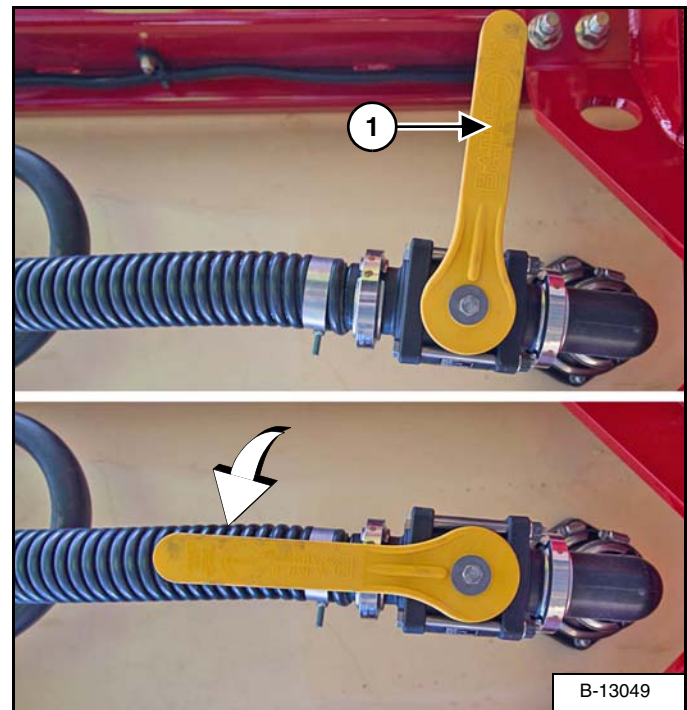

Open tank valve (Item 1) [Figure 30].

Fill the product tank to the desired level.

Monitor the rear sight gauge while filling the product tank. Do not over-fill.

Once the product tank has been filled to the desired level, close the tank valve and the fill valve and disconnect the fill hose.

Install fill cap (Item 1) [Figure 28].

If equipped with a hydraulic / centrifugal pump, check the vent line to insure that the liquid is equal to the level in the tank.

If the pump has become air-locked during the refilling process, bleed the air out of the pump.

Filling Fresh Water Tank



Always use clean, fresh water when filling the fresh water tank.

Figure 31



Remove fill cap (Item 1) [Figure 31].

Fill fresh water tank with clean fresh water daily (Do not allow tank to run low on fresh water). Install fill cap.

NOTE: Use water from fresh water tank to clean, rinse or wash anything that has become contaminated.

FIELD OPERATION

Pre-Operation

Move the tractor and fertilizer applicator to a level area in the field. (See “TRANSPORTING” on page 60.)

Engage the tractor hydraulics. (See the tractor’s operator’s manual for the correct procedure.)

Unfold and fully extend the wings. (See “Transport Position” on page 47.)



Always have the tractor moving forward at a minimum of 3 mph when lowering the toolbar to prevent damage to the coulters.

Move the tractor and fertilizer applicator forward and fully lower the toolbar.

Place all controls in neutral, engage the park brake, stop the engine and wait for all moving parts to stop. Leave the operator’s position.

Verify that the coulters are approximately 2” to 3” below the soil surface.

Adjust coulters as needed to obtain the desired depth.

Figure 32

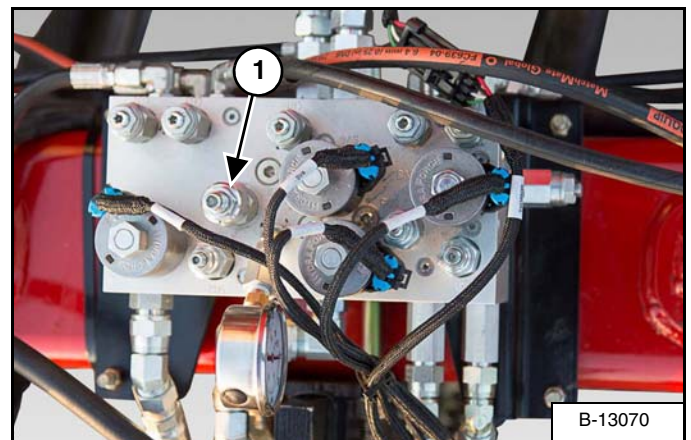

Adjust the pressure reducing valve (Item 1) [Figure 32] as needed to maintain desired wing down-load. (See “ADJUSTING HYDRAULIC PRESSURE” on page 71.)

No adjustment exists for “toolbar folding/unfolding speed”.

Centrifugal Pump (Option)

The pump must always run in a “flooded” condition. Operating the pump in a “non-flooded” condition will cause severe seal damage and possible pump damage.

A “flooded” condition is when the centrifugal pump is completely full of fluid and no pockets of air are present in the pump.

To verify that the pump is flooded, visually check the pump vent line for fluid. Fluid will appear in the vent line when pump is flooded.

In order to get maximum pump efficiency, the mounting and plumbing must meet the following guidelines:

Figure 33

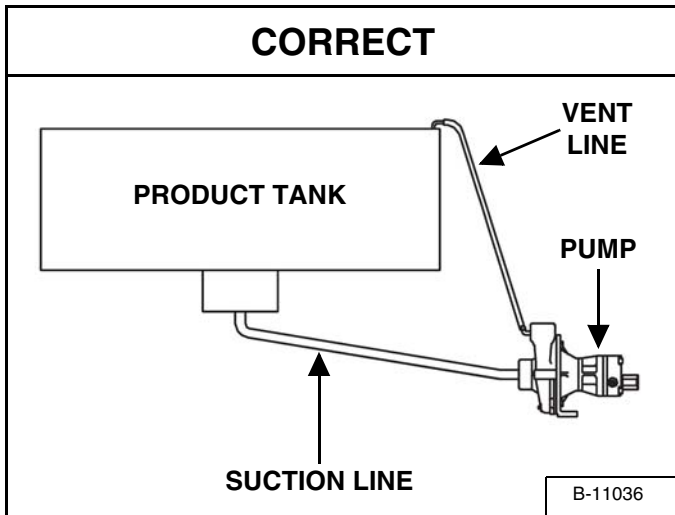

The pump inlet must be mounted below the product tank sump to allow gravity to naturally fill the pump with liquid [Figure 33].

The suction line must have a continual rise from the pump inlet to the tank sump [Figure 33].

The pump must have the vent line plumbed to it [Figure 33].



DO NOT allow an air trap point to occur. Air will be allowed into the pump and may damage components.

Figure 34

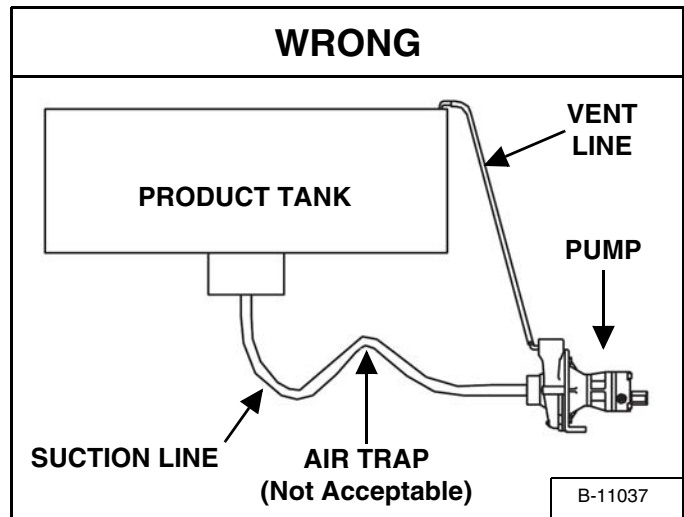

An air trap point will occur if the suction line does not gradually rise from the pump inlet [Figure 34].

Figure 35

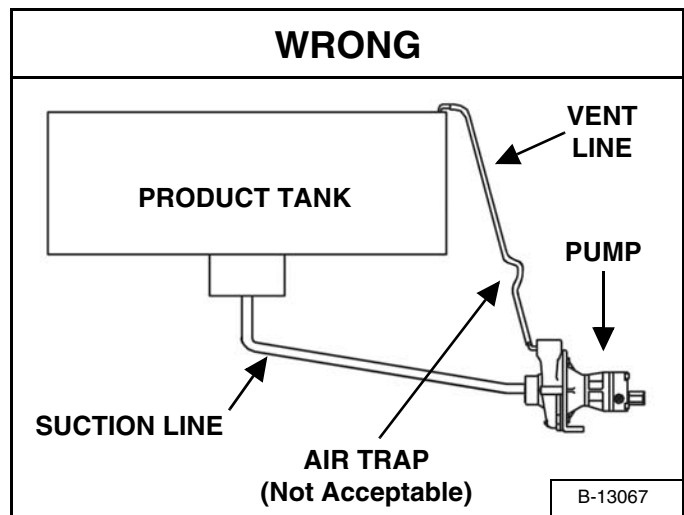

An air trap point will occur if the vent line does not gradually rise from the pump inlet [Figure 35].

JOHN BLUE PUMP SETTING

The NGP pump output is determined by the drive sprocket ratio and the stroke setting. There are two ways to find the proper setting for your pump.

On-line Flow Chart Calculator

Figure 36



ON-LINE FLOW RATE CALCULATOR

www.cds-johnblue.com

QR CODE

The QR code shown [Figure 36] in will give you access to the on-line flow rate calculator when setting pump output.

Slide Chart (Supplied With Pump)

Figure 37

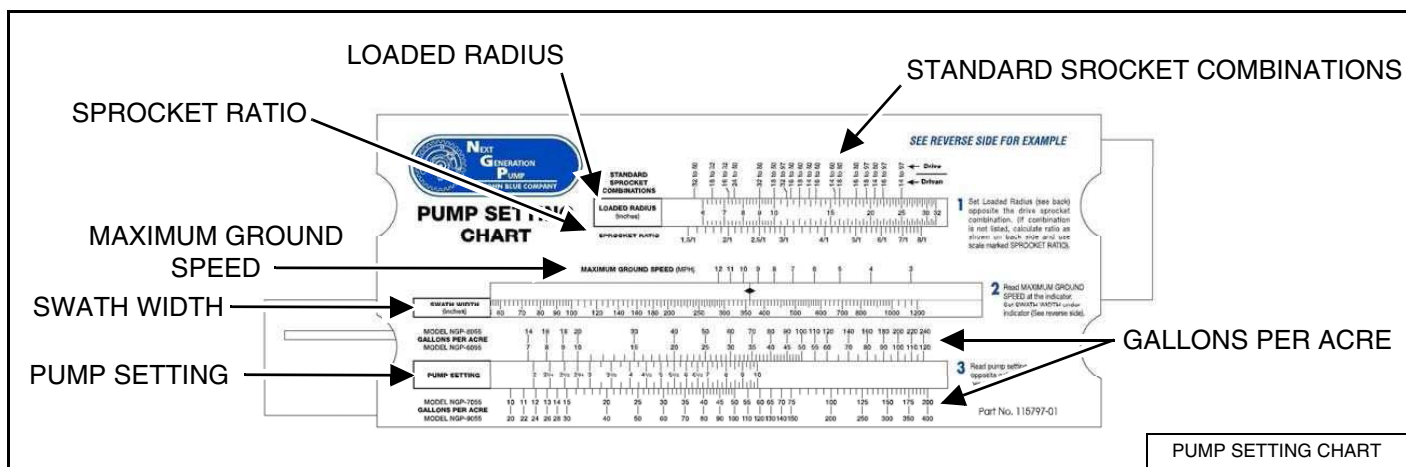

Using the slide chart shown in [Figure 37], supplied with pump - follow example below:

SPROCKET RATIO

Standard Sprocket Combinations

Standard sprocket combinations may be used for equipment with only one chain from the ground or press wheel sprocket to the pump. For example: an applicator with a 50 tooth drive sprocket on the tire driving a 18 tooth driven sprocket on the pump can use the 18 to 50 mark on the slide chart.

$$\frac{\text{Drive Sprocket (50)}}{\text{Driven Sprocket (18)}} = \text{Sprocket Ratio (2.77)}$$

John Blue Twin Piston Pump Test (Option)



The measurement for the loaded radius must be from the manufacturer of the tire or be measured under loaded conditions. The loaded radius tire is always the tire that has the first drive sprocket attached to its hub.

Ground Wheel Drive Arrangement

Figure 38



Measure the loaded radius from the center of the hub to the side of the tire where it rests on the applicator tire [Figure 38].

Press Wheel Drive Arrangement

Measure the loaded radius from the center of the press wheel shaft to where the wheel rests against the tire.

NOTE: The press wheel must be engaged for normal operation to give an accurate reading.

Swath Width

Figure 39

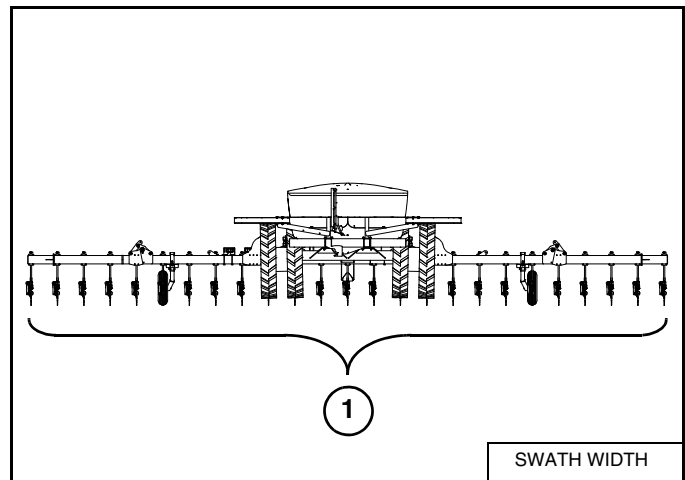

To determine the swath width, multiply the row spacing (in inches) by the number of rows that are being applied; I.E. $12/30'' = 360''$, $16/30'' = 480''$, $24/22'' = 528''$. (Item 1) [Figure 39].

Example: a 16 row 30 inch toolbar would have a swath width of 480 inches, regardless of whether 15 or 17 coulters are used to apply the desired rate of product.

Setting The Pump

Read the desired pump setting from the bottom scale on the pump setting chart.

Loosen the setting pointer nut and rotate the setting hub until the setting pointer is over the desired setting. Tighten the setting pointer nut.

Example: An applicator is equipped with a NGP-9055 series pump, 4.80 - 12 tire, a 50 tooth drive sprocket, and a 18 tooth pump driven sprocket. It is desired to apply 30 gallons per acre on a 480 inch swath.

The following steps will determine correct pump setting:

Figure 40

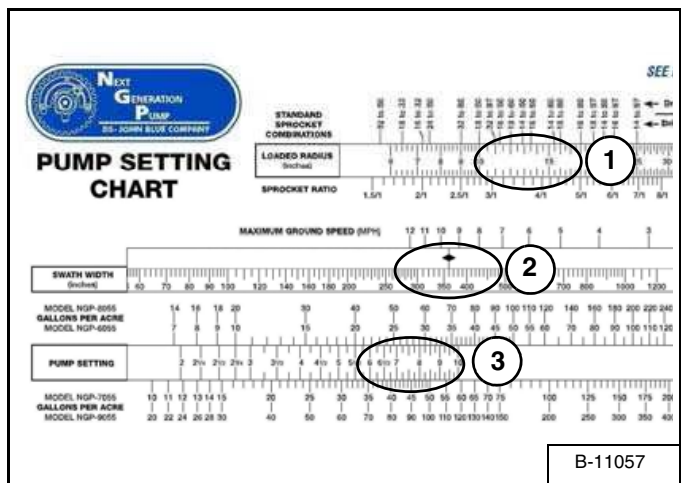

1. Set loaded radius of tire (9.5") under the sprocket combination of 18 to 50 in the top window (Item 1) [Figure 40].
2. Set the swath width (480") under the diamond in the middle window (Item 2) [Figure 40].
3. Read that the pump setting is approximately 9 at 30 gallons per acre on the NGP-9 scale in the bottom window (Item 3) [Figure 40].
4. Set the pump to setting 3.25 to achieve 20 gallons per acre.

NOTE: The maximum ground speed is read above the diamond as approximately 9 mph to avoid exceeding 450 rpm (Item 2) [Figure 40].

Centrifugal Pump / Controller System Test



Review the spray controller operator's manual and be familiar with spray controller calibration and operation before starting.

Dry Test

Figure 41

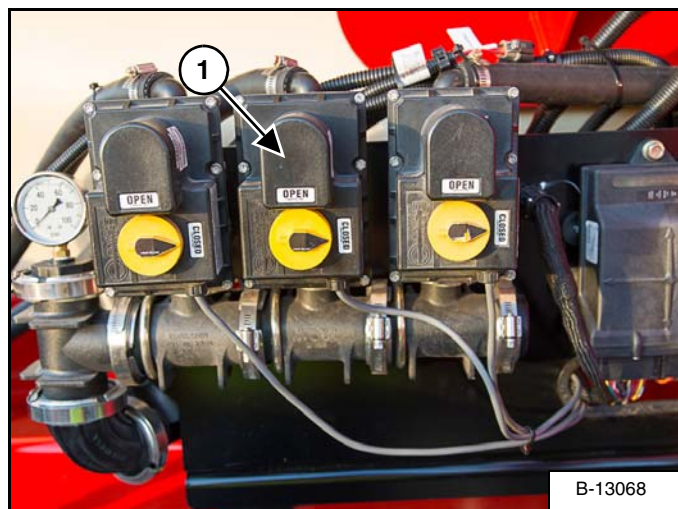

Enter the operator's position and turn the tractor ignition switch to the "ON" position (Do Not start engine.)

Turn the spray controller "ON".

Press wing section switches on the controller, one at a time and operate each of the manifold valves (Item 1) [Figure 41].

Verify that each manifold valve fully opens and closes. Also verify that the correct switch on the controller is operating the correct section manifold valve.

Wet Test

Add approximately 300 gallons of clean water to the product tank. (See “Filling The Product Tank” on page 51.)

Inspect the system for leaks. Repair as needed before operating fertilizer applicator.

Verify that there is liquid in the pump vent line, equal to the level in the tank, as indicated by the rear site gauge.

Determine targeted GPM flow rate.

Select and install properly sized orifices / tips. Perform a “nozzle output check test” to verify application rate.

Inspect spray system components for leaks, loose fittings and possible pinch points. Tighten loose fittings.

Drain system and clean the line strainer screen.

NOTE: Cover spray monitors daily to prevent UV damage to components.

! IMPORTANT

The centrifugal pump must be filled with liquid during operation to cool the seals. Without liquid to cool the seals, pump failure will occur immediately.

NOTE: Maximum hydraulic flow for the pump is 11 gpm. Start with 5 gpm hydraulic flow and increase / decrease as needed.

Verify that the pump is flooded and vent line is filled with fluid.

Enter the operator’s position, start the engine.

Engage the tractor hydraulics. (See the tractor’s operator’s manual for the correct procedure.)

Engage product pump hydraulic circuit (White markers) and place into “detent” position. (See the tractor’s operator’s manual for the correct procedure.)

Turn the spray controller “ON”.

Place the spray controller in “TEST” mode.

Turn all of the manifold section switches “ON”.

Operate the product pump for one minute to flush debris from supply lines (If required). Always turn off the pump by moving the hydraulic control to the “float” position.

! IMPORTANT

Always shut off the pump by moving the hydraulic control to the “float” position to allow the pump to spin freely to a stop. Failure to do so may cause severe pump failure.

Operating The Fertilizer Applicator

! IMPORTANT

IDEAL OPERATION - Use the tractor's hydraulics to lower and raise the toolbar. To lower, simply move the tractor's hydraulic control to the detent position. To raise, hold the control until the toolbar is fully raised.

Enter the operator's position, start the engine and release the parking brake.

Engage the tractor hydraulics. (See the tractor's operator's manual for the correct procedure.)

NOTE: The following image may not show your exact fertilizer applicator as it appears but the procedure is correct.

Figure 42



Fully raise the toolbar [Figure 42].

Move the tractor and fertilizer applicator to the starting area in the field.

Align the tractor and fertilizer applicator with field / rows.

! IMPORTANT

Always have the tractor moving forward at a minimum of 3 mph or more when lowering the toolbar to prevent damage to the coulters.

Drive the tractor and fertilizer applicator forward, towards the starting point.

As the front tires of the tractor make contact with the field / rows (starting point), fully lower the toolbar by placing the "Work Circuit" SCV control lever directly into detent.

NOTE: Placing the "Work Circuit" SCV control lever into detent will maintain constant down pressure during the application process.

Engage the product pump and turn on the sectional control valves using the spray controller to start application process.

As the tractor approaches the end of the field / rows, turn the sectional control valves "Off" and fully raise the toolbar.

! CAUTION

PREVENT COULTER DAMAGE

Always fully raise the toolbar before turning the tractor and fertilizer applicator and when moving the tractor and fertilizer applicator to starting point in the field.

Align the tractor and fertilizer applicator with next application area.

As the front tires of the tractor make contact with the field / rows (next application area), fully lower the toolbar and place the "Work Circuit" SCV control lever into detent.

Continue the application process until the desired area / field is complete.



Always flush product tank and system with clean water before leaving the application area / field.

Stop the tractor and fertilizer applicator on a level surface in the field.

Place all controls in neutral, engage the park brake, stop the engine and wait for all moving parts to stop. Leave the operator's position.

Clean the product tank. (See "Cleaning The Product Tank" on page 75.)

Ensure that the toolbar is in the fully raised position. Place the toolbar and wings in the transport position. (See "TRANSPORTING" on page 60.)

Operating Guidelines

- Toolbar level, across all sections when engaged on level ground.
- Gauge wheels on wings should carry the weight of wing.
- Changes in air temperature, hydraulic oil temperature and field conditions (soil type, moisture, crop, etc.) may affect operating performance of hydraulic functions and require adjustments.

TRANSPORTING

Requirements

Always comply with federal, state, local and provincial laws regarding the transport of farm equipment on public roadways.



Never exceed 20 mph (32 kph).



Use of an unapproved hitch or tractor / tow vehicle can result in loss of control, leading to serious injury or death.

Tractor / tow vehicle and hitch must have the rated capacity to tow equipment.

Verify that the tractor / tow vehicle is approved for transporting the equipment and that the equipment is securely attached to the tractor / tow vehicle.

Verify safety chain is installed and properly connected before transporting equipment.

Verify 7 pin electrical harness is connected and safety lights are working properly.

Verify that the SMV (Slow Moving Vehicle) emblem, all lights and reflectors are clean and visible.

Enter the operator's position, start the engine and release the parking brake.

Engage the tractor hydraulics. (See the tractor's operator's manual for the correct procedure.)

Figure 43

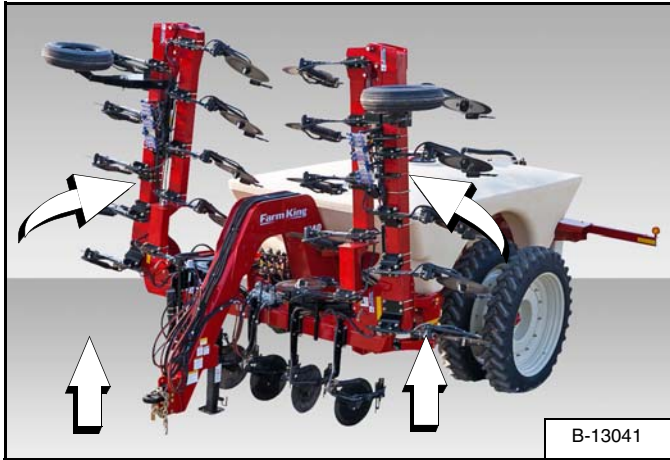

Lift the toolbar into the fully raised field position [Figure 43].

Fold wings. (See “Transport Position” on page 47.)

Install “Red” cylinder stops onto the center toolbar lift cylinders. Lower the toolbar down to the stops. The toolbar's folded, fully raised position, may exceed maximum height restrictions. Failure to lower the toolbar to the proper transport height may result in severe equipment damage.

Transporting Guidelines



AVOID SERIOUS INJURY OR DEATH

DO NOT transport a loaded fertilizer applicator on public roadways. Excess weight will greatly increase tractor stopping distance and may cause the operator to lose control of the tractor or tow

The ratio of the tractor / tow vehicle weight to the loaded equipment weight plays an important role in defining acceptable travel speed.

TRAVEL SPEED - Acceptable travel speed.

WEIGHT RATIO - Weight of fully equipped or loaded implement(s) relative to weight of tractor / tow vehicle.

TRAVEL SPEED	WEIGHT RATIO
Up to 20 mph (32 kph)	1 to 1 (or less)
Up to 10 mph (16 kph)	2 to 1 (or less)
DO NOT TOW	More than 2 to 1

Farm King



MAINTENANCE

TRUBLESHOOTING65
 Chart65

SERVICE SCHEDULE67
 Maintenance Intervals67

LUBRICATION68
 Recommendations68
 Locations68

ADJUSTING HYDRAULIC PRESSURE71
 Procedure71

AXLES73
 Wheel Nut Torque73
 Tire / Wheel Replacement73
 Tire Pressure74
 Tire Rating Chart74

CLEANING75
 Cleaning The Product Tank75
 Cleaning The Line Strainer Screen76
 Cleaning The Fertilizer Applicator76

SAFETY SIGN (DECAL) INSTALLATION76
 Procedure76

STORAGE AND RETURN TO SERVICE77
 Storage77
 Return To Service77

Farm King



TROUBLESHOOTING

Chart



Instructions are necessary before operating or servicing equipment. Read and understand the Operator And Parts Manual and safety signs (decals) on equipment. Follow warnings and instructions in the manuals when making repairs, adjustments or servicing. Check for correct function after adjustments, repairs or service. Untrained operators and failure to follow instructions can cause injury or death.

NOTE: If a problem is encountered that is difficult to solve, even after having read through this troubleshooting section, please call your local Farm King dealer. Before you call, please have this Operator And Parts Manual and the serial number of your machine at hand.

PROBLEM	CAUSE	CORRECTION
Coulters float out of the ground during field operation.	“Work Circuit” SCV control lever valve is not placed into detent.	Make sure that the Work Circuit is in detent during the entire work cycle.
	Pressure reducing valve is not set high enough for soil conditions.	Increase pressure up by 100 psi increments until gauge wheels maintain constant contact with the ground.
Wings do not raise or lower evenly.	Flow divider is not functioning properly.	Check, replace if necessary. Lower the hydraulic flow to 6 - 8 gpm.
When the wings are horizontal and the directional valves are not being used, the wings drift oppositely, one up, one down.	The pilot operated check valves are not operating properly.	Check, replace if necessary.
	Hydraulic flow is too high.	Adjust hydraulic flow.
During transport unfold, toolbar does not stop when toolbar wings achieve the unfolded, level position.	No power to proximity switch, solenoid valve (2) is not enabled.	Check to make sure all electrical connections are good.
	Proximity switch is improperly adjusted.	Adjust proximity switch position to enable solenoid valves at the correct height.
	Solenoid valve (2) is not functioning properly.	Check, replace if necessary.

PROBLEM	CAUSE	CORRECTION
During field operation, lifting the toolbar for end row turns, the wings do not stop approx. 15° above level.	No power to proximity switch, solenoid valve (1) is not enabled.	Check to make sure all electrical connections are good.
	Proximity switch is improperly adjusted.	Adjust proximity switch position to enable solenoid valves at the correct height.
	Solenoid valve (2) is not functioning properly.	Check, replace if necessary.
	Hydraulic flow is too high (above the recommended 6 - 8 gpm rate).	Adjust hydraulic flow.
	Circuit selector switch is in the wrong position, or not used entirely.	Check circuit selector switch.
When lowering toolbar to field operation position, the center section lift cylinders chatter or does not lower.	Counter balance valve is cycling in rapid succession, insufficient oil flow.	Increase oil flow from tractor SCV.
	Counter balance valves out of adjustment.	Check adjustment, replace if necessary.
	Defective counter balance valve.	Replace valve.
Outer coulters run too deep or center section runs too shallow. The toolbar does not seem to be parallel to the soil profile.	Improper depth settings.	Change depth control stops on the center section lift cylinders.
		Reset wing gauge wheel height.
During transport unfold, toolbar chatters and / or bounces.	Tractor oil flow through transport circuit valve is set too high.	Reduce tractor flow rate until chatter or bounce stops, 6 to 8 GPM.
When folding to transport position, inner wing folds with or before outer wings.	Tractor oil flow through transport circuit valve is set too high.	Reduce tractor flow rate to 6 to 8 gpm.

SERVICE SCHEDULE

Maintenance Intervals

Maintenance work must be done at regular intervals. Failure to do so will result in excessive wear and early failures. The service schedule is a guide for correct maintenance of the Fertilizer Applicator.



Instructions are necessary before operating or servicing equipment. Read and understand the Operator and Parts Manual and safety signs (decals) on equipment. Follow warnings and instructions in the manuals when making repairs, adjustments or servicing. Check for correct function after adjustments, repairs or service. Untrained operators and failure to follow instructions can cause injury or death.

#	DESCRIPTION	SERVICE PROCEDURES						
		Winterize	Clean	Lube	Change	Cover	Drain	Locations
Daily Maintenance (or every 8 hours)								
1	Fresh Water Tank				•		•	
2	Coulter Lower Parallel Arm			•				
3	Coulter Pivots			•				
4	Spray Monitor					•		
Weekly (or every 50 hours)								
4	Line Strainer Screen		•					
5	Parallel Linkage, Wing Hinge Points, Wing Fold Linkage			•				
Every 250 hours								
6	Wheel Bearings (running gear and gauge wheels)			•				
7	Coulter Hub Bearings			•				
Annually (or every 500 hours)								
8	Product Tank	•	•					
9	Machine	•	•					
10	Spray Monitor	•	•			•		

LUBRICATION

Recommendations

Always use a good quality multi-purpose / lithium base grease when lubricating the equipment.



Do not over-grease bearings. Greasing too often can damage seals and lead to premature bearing failure.



Only sealed bushings are used on the applicator. Do not over-grease.

- Always use a hand-held grease gun.
- Clean fitting before greasing, to avoid injecting dirt and grit.
- Replace and repair broken fittings immediately.
- If fittings will not take grease, remove and clean thoroughly. Replace fitting if necessary.

Locations



Fluids such as engine oil, hydraulic fluid, coolants, grease, etc. must be disposed of in an environmentally safe manner. Some regulations require that certain spills and leaks on the ground must be cleaned in a specific manner. See local, state and federal regulations for the correct disposal.

Lubricate the following grease locations EVERY 8 HOURS:

Figure 44

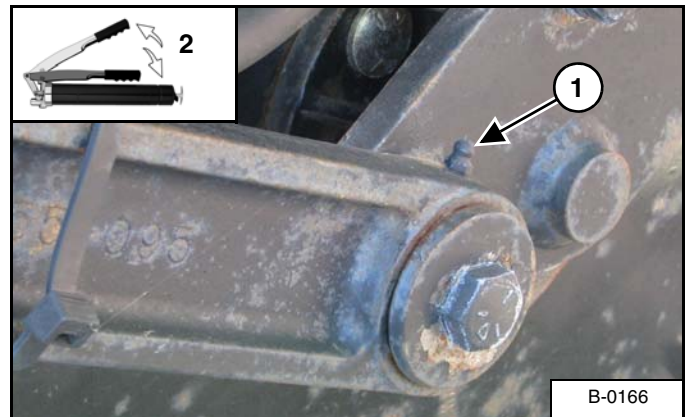

Apply two pumps of grease to the coulters lower parallel arm (Item 1) [Figure 44].

Figure 45

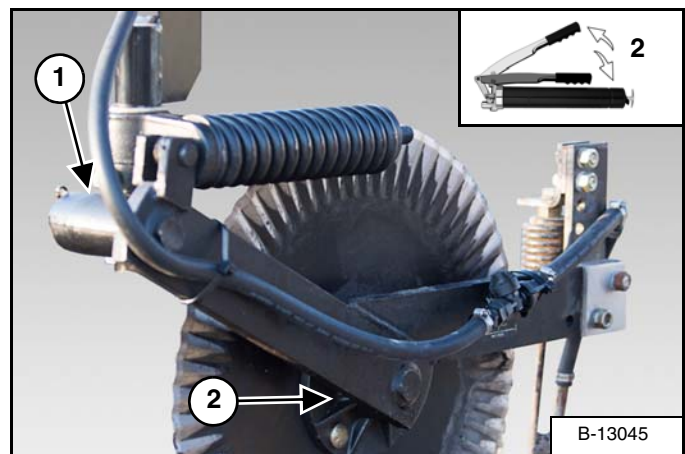

Apply two pumps of grease to the coulters pivots (Item 1) and to the pressed hub assembly (Item 2) [Figure 45].

Lubricate the following grease locations EVERY 50 HOURS:

Figure 46

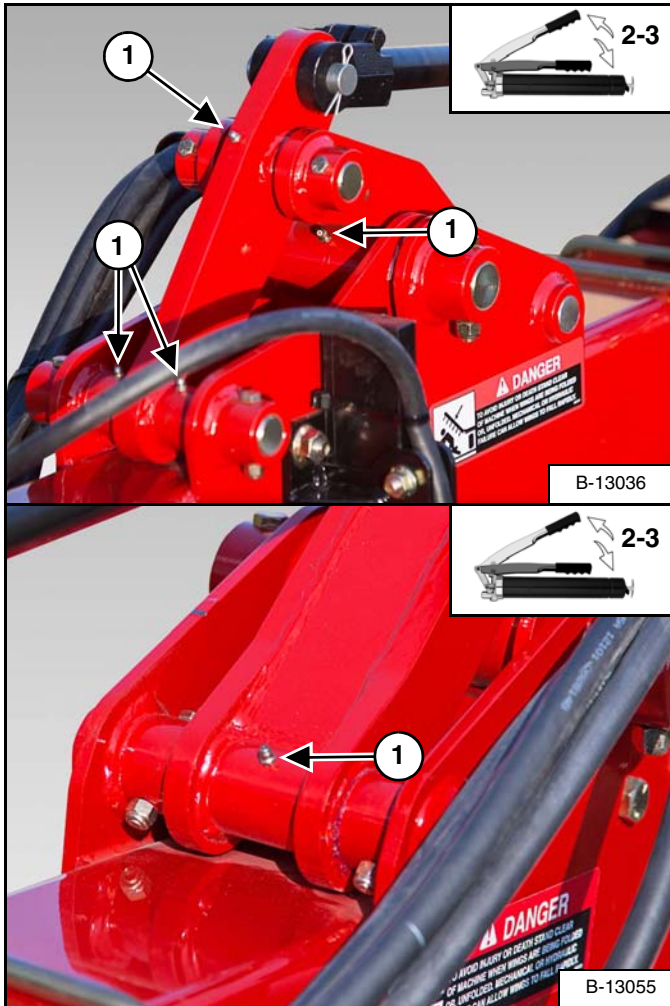

Apply two - three pumps of grease to the wing fold joints (Item 1) [Figure 46] on the outer wing hinge points.

Figure 47

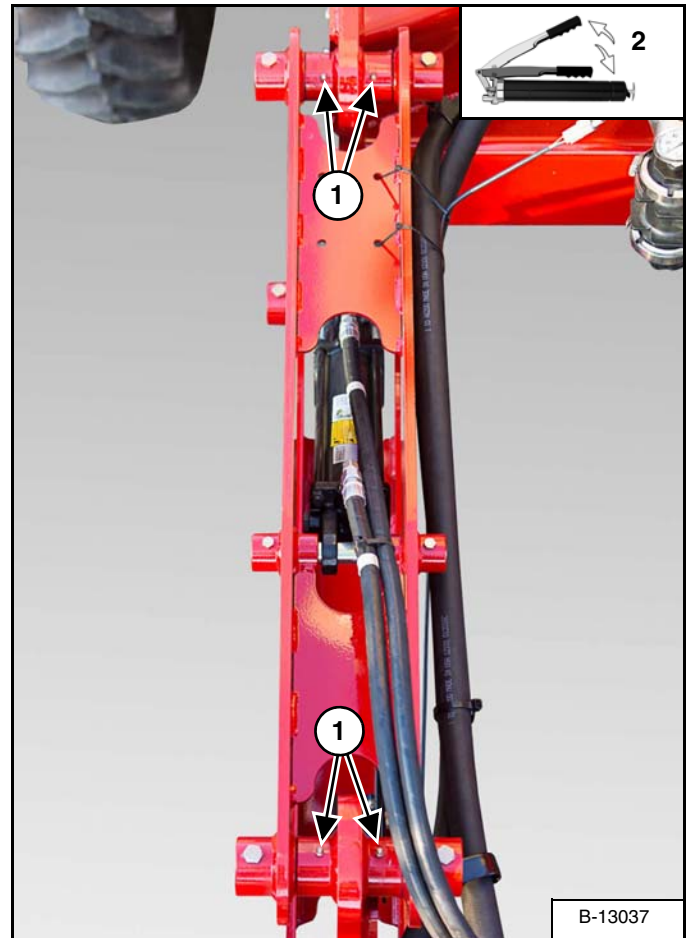

Apply two pumps of grease to the four grease zerks (Item 1) [Figure 47] on each parallel lift arm.

Figure 48

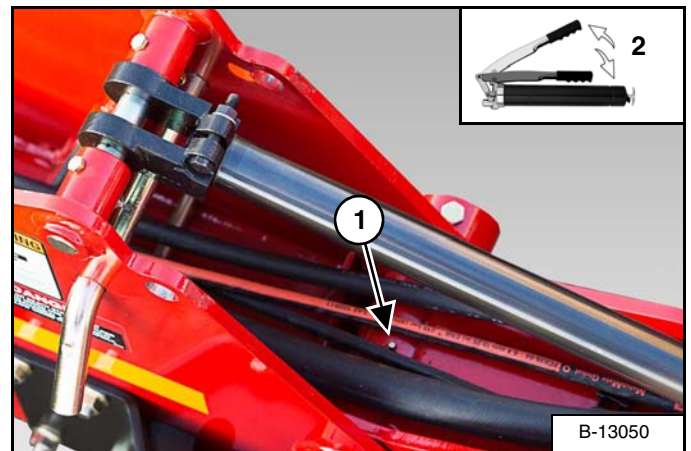

Apply two pumps of grease to the grease zerk (Item 1) [Figure 48] on each inner wing hinge point.

Lubricate the following grease locations EVERY 250 HOURS:

Figure 49

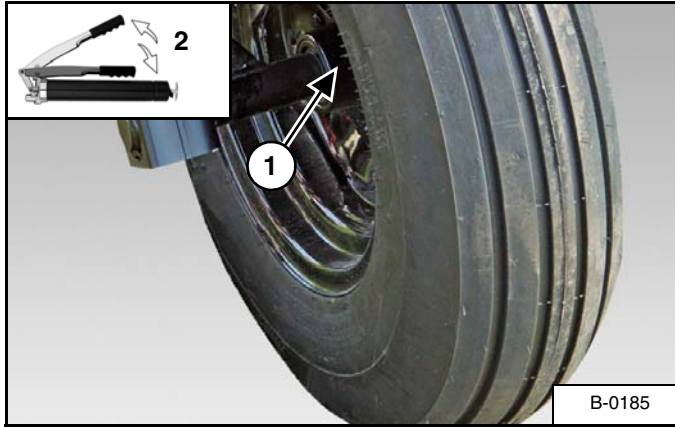

Apply two pumps of grease poly urea based EP to the gauge wheel hubs (Item 1) [Figure 49].

Figure 51

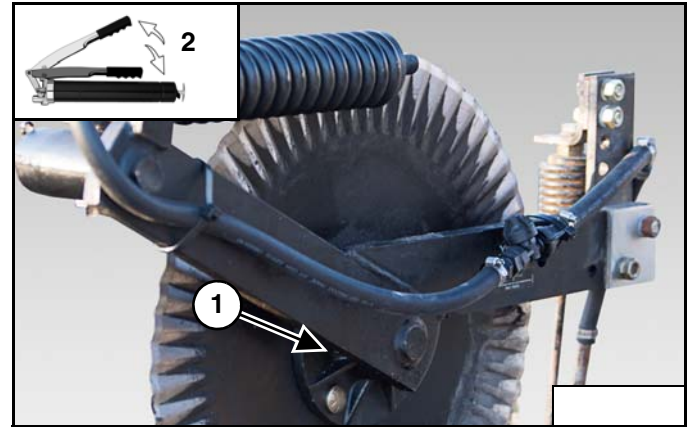

Apply two pumps of grease to the coulters hub bearings (Item 1) [Figure 51].

Figure 50

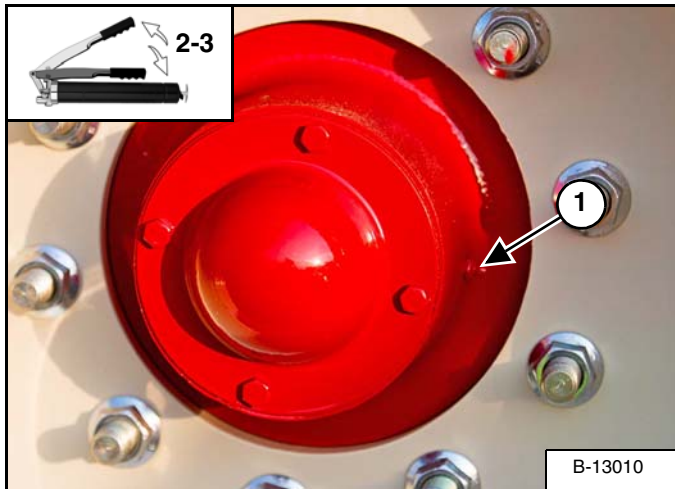

Apply two - three pumps of grease to the running wheel bearings (Item 1) [Figure 50].

ADJUSTING HYDRAULIC PRESSURE

Procedure

NOTE: The pressure reducing valve (PR1) controls the amount of downward pressure applied to the wing sections. The adjustment range is from 800 to 1,500 PSI. The factory setting is 800 to 1,100 PSI, which is adequate for most conditions.

IMPORTANT

DOWN PRESSURE ON WING SECTIONS

- Too much down pressure will put unnecessary stress on the machine and will put more load on the gauge wheels.
 - Too little pressure may not keep the coulters in the ground at the proper depth.
-

IMPORTANT

Always check with a pressure gauge while the SCV control lever is left in the detented position. **DO NOT** adjust the pressure without a pressure gauge.

IMPORTANT

DO NOT MAKE HYDRAULIC PRESSURE ADJUSTMENTS ON HARD / PAVED SURFACE.

Move the tractor and fertilizer applicator to a soft level area.

Engage the parking brake, relieve hydraulic pressure, turn engine off and leave the operator's position. (See "Entering And Leaving The Operator's Position" on page 41.)

Figure 52

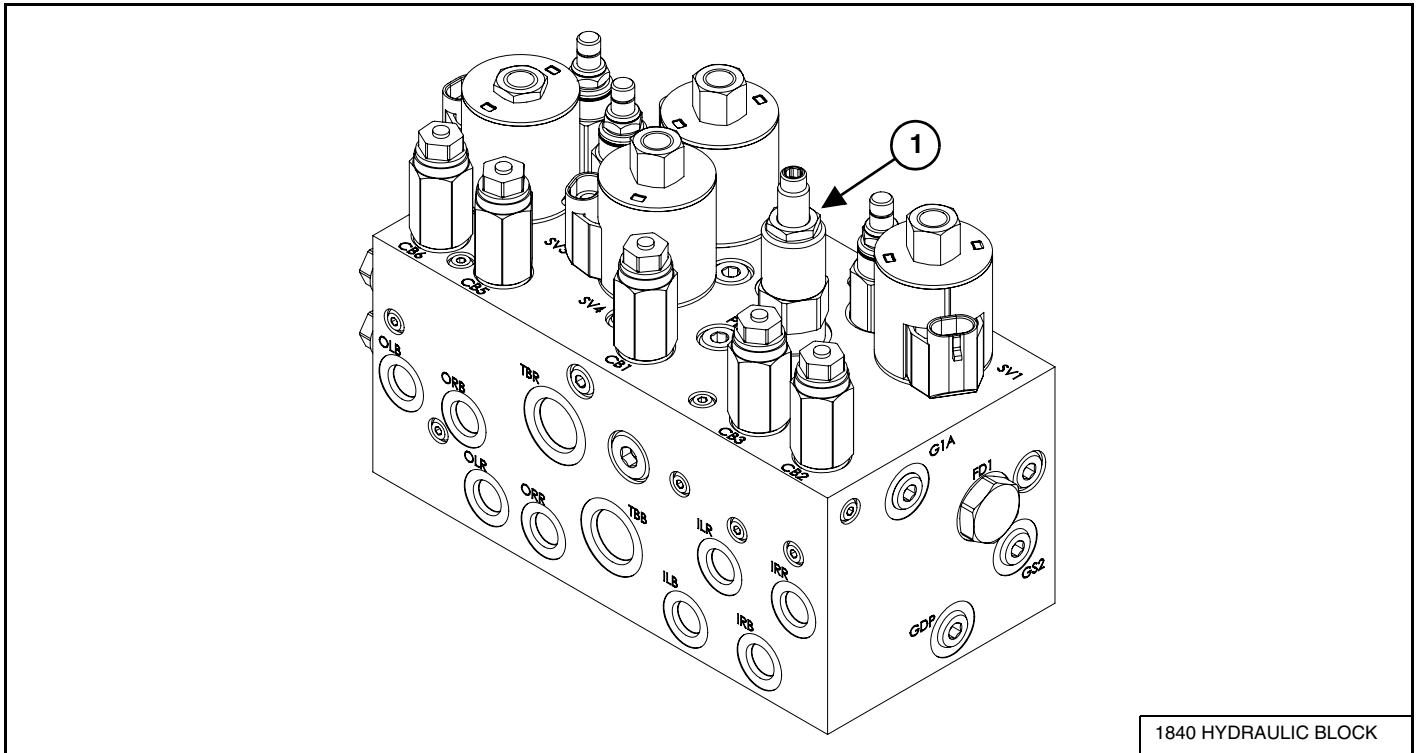

1840 HYDRAULIC BLOCK

Verify that all hydraulic hoses and electrical harnesses are connected to the tractor.

Enter the tractor, start the engine and engage the tractor's auxiliary hydraulics.

Unfold inner wings, allow pressure to build, outer wings unfold. Lower the toolbar to the ground (Need to be moving >3 mph to lower the toolbar to the ground, in field conditions, not hard surfaces such as asphalt, concrete, gravel, granite, or packed soil.).

Lock or place the SCV control lever in detent (Work Circuit). Run engine at operating speed.

Leave the operator's position.

Using a 3/4" (19 mm) wrench, loosen the lock nut on the pressure reducing valve (Item 1) [Figure 52].

While watching the 3000 PSI gauge,

- Turn the set screw clockwise to increase pressure or turn set screw counter-clockwise to decrease pressure until the desired down pressure (approximately 800 psi) is achieved.

Tighten lock nut on the pressure reducing valve.

Enter the operator's position, release parking brake, raise the toolbar and move the tractor and fertilizer applicator to the field (work area). Test the fertilizer applicator in the field (work area).

NOTE: If further adjustment is required, repeat the above procedure until the desired pressure is achieved.

AXLES

Wheel Nut Torque



CHECK WHEEL NUTS AFTER:

1. First 3 (three) hours of field operation.
2. First 10 (ten) hours of field operation.
3. First 50 (fifty) hours of field operation.
4. Every 200 (two hundred) hours of operation.

REPEAT PROCEDURE IF A WHEEL IS REMOVED OR REINSTALLED

Tighten wheel nuts to 420 ft.-lb. (567 N•m) torque.

Tire / Wheel Replacement

Periodically check tires for cuts, bulges and damaged rims.



AVOID INJURY OR DEATH

Before you leave the operator's position:

- Always park on a flat level surface.
- Place all controls in NEUTRAL.
- Engage the park brake.
- Stop the engine and remove the key.
- Wait for all moving parts to stop.

Park the tractor / equipment on a flat level surface.

Place all controls in neutral, engage the park brake, stop the engine and wait for all moving parts to stop. Leave the operator's position.

Fully raise wings into transport position and secure.



AVOID INJURY OR DEATH

- Always chock tires before performing any maintenance or service.

Place chock blocks behind and in front of the opposite tire to be removed.

Raise axle frame with jack until the tire / wheel is slightly off the ground.

NOTE: Place blocks / stands under the frame to secure the fertilizer applicator when tire / wheel is raised off the ground.

Remove the ten wheel nuts and tire assembly.

Figure 53

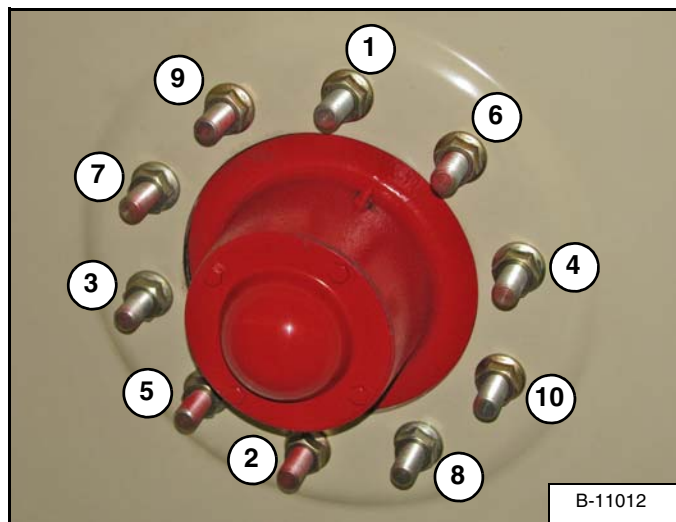

Install the new tire with the valve stem facing out.

Reinstall ten wheel nuts (Items 1 - 10) [Figure 53].

Tighten wheel nuts in a criss-cross pattern [Figure 53]. Tighten wheel nuts to 420 ft.-lb. (567 N•m) of torque.

Lower tire / wheel assembly to the ground.

After tightening the wheel nuts, pull the fertilizer applicator approximately one (1) mile and re-tighten the wheel nuts to 420 ft.-lb. (567 N•m) of torque.

Tire Pressure



When inflating tires, use a clip-on chuck and extension hose long enough to allow you to stand to one side and NOT in front of or over the tire assembly.

Check tire pressure daily. Fill tires per tire manufacturer's recommendation. See side wall of tire for inflation requirements.

Tire Rating Chart



EXCEEDING THE MAXIMUM LOAD, AS SPECIFIED IN THE OPERATOR'S MANUAL, MAY RESULT IN TIRE FAILURE AND WILL VOID WARRANTY.

TIRE SIZE	TIRE PSI	MAX LOAD MPH	MAX LOAD LBS
320/90R50	70	40	12,800
380/90R46	78	30	12,300

CLEANING



CHEMICAL HAZARD

To prevent serious injury or death:

WEAR PERSONAL PROTECTIVE EQUIPMENT

- Do not allow chemical or solution to touch skin. Some chemicals can be absorbed through the skin.
- Wear rubber gloves and protective gear at all times.

DON'T BREATHE VAPOR

- Avoid chemical splash and vapor. Keep others away.
- Do not breathe vapor.
- Wear proper respirator when working with chemicals.
- Chemicals can be toxic.

DON'T INGEST CHEMICAL

- If in eyes or mouth, read manufacturer's instructions and follow them exactly.
- Seek immediate medical attention.
- A poison control number is usually inside the front cover of your telephone book.



The tank and system must be emptied of chemical mixture and flushed with clean water before servicing the spray system or spraying components.



Do not spill chemicals on skin or clothing. If chemicals are spilled, remove contaminated clothing immediately and wash skin (and clothing) thoroughly with soap and water. Wash hands and face with soap and water and change clothing after spraying.



Rinse and clean any exterior surfaces and components immediately if any liquid fertilizer spills or leaks occur.

Cleaning The Product Tank

Fill product tank approximately half full, with clean water. (See "Filling The Product Tank" on page 51.)

Engage product pump and flush out through the nozzles.

Add a proper cleaning agent and fill product tank approximately half full one more time.

Engage product pump and flush out through the nozzles.

Fill product tank approximately half full, with clean water, engage product pump and flush out through the nozzles for the final rinse.

Cleaning The Line Strainer Screen

Clean the line strainer screen every 50 hours of operation.



The tank and system must be emptied of chemical mixture and flushed with clean water before servicing the spray system or spraying components.

Figure 54

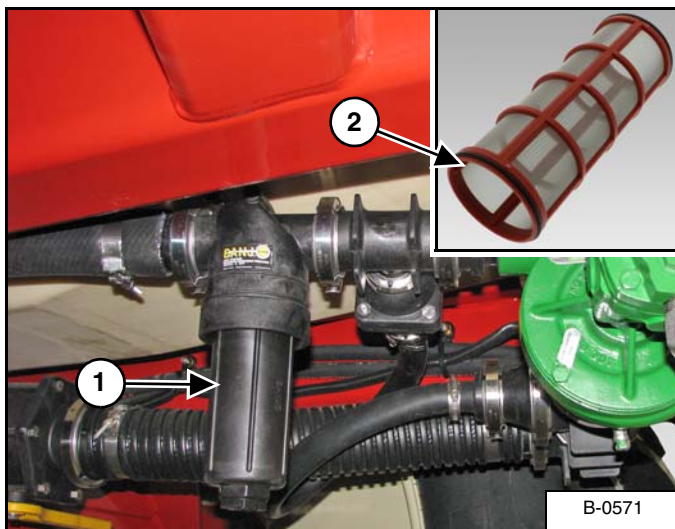

Loosen and remove the line strainer canister (Item 1) [Figure 54] by hand (do not use a wrench).

Remove screen (Item 2) [Figure 54] and clean from the inside with clean water.

Inspect the screen for holes or tears. If the screen is damaged, replace the screen.

Install screen and line strainer canister. Hand tighten the line strainer canister (do not use a wrench).

Cleaning The Fertilizer Applicator

Clean and rinse all exterior surfaces and components with clean water and cleaning agent to prevent corrosion.

SAFETY SIGN (DECAL) INSTALLATION

Procedure



When replacing safety signs (decals), the temperature must be above 10° C (50° F).

- Remove all portions of the damaged safety sign (decal).
- Thoroughly clean the area with adhesive remover and glass cleaner. Remove all adhesive residue.
- Allow the area to dry completely before installing the new safety sign (decal).
- Position the safety sign (decal) in the correct location. Remove a small portion of the backing paper on the safety sign (decal).
- Press on the safety sign (decal) where the backing paper has been removed.
- Slowly remove the remaining backing paper, pressing on the safety sign (decal) as the backing paper is removed.
- Using the backing paper, pressing firmly, move the backing paper over the entire safety sign (decal) area.

NOTE: Small air pockets can be pierced with a pin and smoothed out using the piece of the backing paper.

STORAGE AND RETURN TO SERVICE

Storage

Sometimes it may be necessary to store your Farm King Fertilizer Applicator for an extended period of time. Below is a list of items to perform before storage.



DO NOT permit children to play on or around the stored machine.

- Fill product tank approximately half full, with clean water and flush out toolbar / wings. Repeat three times.
- Thoroughly wash the machine with a pressure washer or water hose to remove all dirt, mud, debris or residue.
- Remove orifices and / or spray tips from the coulters assembly. Wash thoroughly. Apply a thin layer of grease to coulters blades/knives and exposed cylinder shafts to prevent rust.
- Winterize with RV antifreeze.
- Lubricate all bushings to remove any water residue from washing.
- Remove any material that has become entangled around any moving part.
- Raise and fold the toolbar and wings into their fully up and retracted configuration.
- Install mechanical wing lock system to prevent wings from drifting outward during storage.
- Clean, flush, drain and cover spray monitors with an opaque material (lawn / leaf garbage bag) to protect from UV damage.
- Place hydraulic hoses and 7-pin connector in the storage brackets.
- Inspect the hitch and all welds on the equipment for wear and damage.
- Check for loose hardware, missing guards, or damaged parts.
- Check for damaged or missing safety signs (decals). Replace if necessary.
- Replace worn or damaged parts.
- Touch up all paint nicks and scratches to prevent rusting.
- Place the equipment in a dry protected shelter.

NOTE: If a dry protected shelter is not available, cover with a waterproof tarp and tie down securely.

- Support the jack / frame with planks if required.

Return To Service

After the Farm King Fertilizer Applicator has been in storage, it is necessary to follow a list of items to return the equipment to service.

- Be sure all shields and guards are in place.
- Lubricate the equipment.
- Connect to a tractor and operate equipment, verify all functions operate correctly.
- Check for leaks. Repair as needed.

Farm King



PARTS IDENTIFICATION

GENERAL PARTS INFORMATION	83
SINGLE AXLE ASSEMBLY - 120 IN.	83
SINGLE AXLE ASSEMBLY 132 IN.	84
ADJUSTABLE AXLE ASSEMBLY (OPTIONAL)	85
DUAL AXLE ASSEMBLY - 20 / 22	86
DUAL AXLE ASSEMBLY - 30	87
DUAL AXLE ASSEMBLY - 38	88
HUB ASSEMBLY	89
FRAME GROUP	90
HITCH GROUP	92
TANK SUPPORT	94
TANK SUPPORT FRONT	95
TANK SUPPORT REAR	96
TANK ASSEMBLY	97
TANK BAFFLE GROUP	98
SIGHT GAUGE ASSEMBLY	99
FRONT SIGHT GAUGE	100
REAR SIGHT GAUGE	101
HAND / EYE WASH GROUP	102
HAND / EYE WASH TANK ASSEMBLY (CREAM)	103
TOOLBAR ASSEMBLY (325 / 370 IN.)	104
TOOLBAR ASSEMBLY (325 / 400.5 IN.)	106
TOOLBAR ASSEMBLY (325 / 489.5 IN.)	108
TOOLBAR ASSEMBLY (325 / 533 IN.)	110
TOOLBAR ASSEMBLY (357 / 533 IN.)	112
TOOLBAR ASSEMBLY (375 / 489.5 IN.)	114
TOOLBAR ASSEMBLY (400 / 533 IN.)	116
TOOLBAR BASE ASSEMBLY	118
TOOLBAR ASSEMBLY (325 IN.)	120
GAUGE WHEEL	121
GAUGE WHEEL HUB	122
TOOLBAR GOOSE HOOK ASSEMBLY	123
ACE PUMP & PLUMBING ASSEMBLY	124

ACE PUMP & PLUMBING SUB-ASSEMBLY	126
PRODUCT PUMP ASSEMBLY	128
JB TWIN PUMP PLUMBING ASSEMBLY (1 OF 3)	130
JB TWIN PUMP PLUMBING ASSEMBLY (2 OF 3)	132
JB TWIN PUMP PLUMBING ASSEMBLY (3 OF 3)	134
JOHN BLUE SUB-ASSEMBLY	136
1 SECTION CONTROL VALVE ASSEMBLY	138
3 SECTION CONTROL VALVE ASSEMBLY	140
JB MANIFOLD JUNCTION ASSEMBLY	142
SUMP MANIFOLD GROUP	144
QUICK FILL GROUP	145
TOOLBAR PLUMBING GROUP	146
Center Section Spray Monitor	146
Single Column Spray Monitor	147
Coulter Injector Hose Assembly	148
Coulter Knife Hose Assembly	148
COULTER BRACKET GROUP	149
16 Row - 20" Spacing 17 Coulters	149
16 / 18 Row - 20" Spacing 17 / 19 Coulters	150
16 / 24 Row - 20" Spacing 17 / 25 Coulters	151
18 / 24 Row - 20" Spacing 19 / 25 Coulters	152
14 Row - 22" Spacing 15 Coulters	153
14 / 16 Row - 22" Spacing 15 / 17 Coulters	154
14 / 18 Row - 22" Spacing 15 / 19 Coulters	155
14 / 24 Row - 22" Spacing 15 / 25 Coulters	156
16 / 24 Row - 22" Spacing 17 / 25 Coulters	157
18 / 24 Row - 22" Spacing 19 / 25 Coulters	158
10 / 12 Row - 30" Spacing 11 / 13 Coulters	159
10 / 16 Row - 30" Spacing 11 / 17 Coulters	160
12 / 16 Row - 30" Spacing 13 / 17 Coulters	161
8 / 12 Row - 38" Spacing 9 / 13 Coulters	162
RIPPLE COULTER W / INJECT GROUP	163
11 Coulter Assembly	163
13 Coulter Assembly	163
15 Coulter Assembly	163
17 Coulter Assembly	163
19 Coulter Assembly	163
25 Coulter Assembly	163
RH 2996 FERT COULTER LIQUID KNIFE	164
COULTER W/INJECTOR ASSEMBLY	168

COULTER ARM ASSEMBLY	170
RH W / Injector	170
RIPPLE COULTER W / KNIFE GROUP	172
11 Coulter Assembly	172
13 Coulter Assembly	172
15 Coulter Assembly	172
17 Coulter Assembly	172
19 Coulter Assembly	172
25 Coulter Assembly	172
TIRE / WHEEL SINGLE 320 / 90 R50	173
TIRE / WHEEL SINGLE 380 / 90 R46	174
TIRE / WHEEL STRADDLE DUAL, 20 IN SPACING	175
TIRE / WHEEL STRADDLE DUAL, 22 IN SPACING	176
TIRE / WHEEL STRADDLE DUAL, 30 IN SPACING	177
TIRE / WHEEL STRADDLE DUAL, 38 IN SP	178
MARKING GROUP ASSEMBLY	179
LIGHTING MARKING GROUP	180
HYDRAULIC GROUP, W / INNER WINGS ONLY	182
HYDRAULIC GROUP, W/ INNER AND OUTER WINGS	184
HYDRAULIC BLOCK	186
HYDRAULIC BLOCK COMPONENTS	188
RAVEN 450 (OPTIONAL)	190
RAVEN VIPER 4 W / GPS (OPTIONAL)	191
ISOBUS (OPTIONAL)	192
SCS440 / 450 HARNESS ONLY (OPTIONAL)	194
RAVEN PHOENIX 10 GPS (OPTIONAL)	196
OUTER WING CYLINDER	197
INNER WING CYLINDER	198
MAIN LIFT CYLINDER	199

GENERAL PARTS INFORMATION

The parts identification section list descriptions, part numbers and quantities for all North America Base Model 1840 fertilizer applicators. Contact your Farm King dealer for additional fertilizer applicator parts information.

SINGLE AXLE ASSEMBLY - 120 IN.

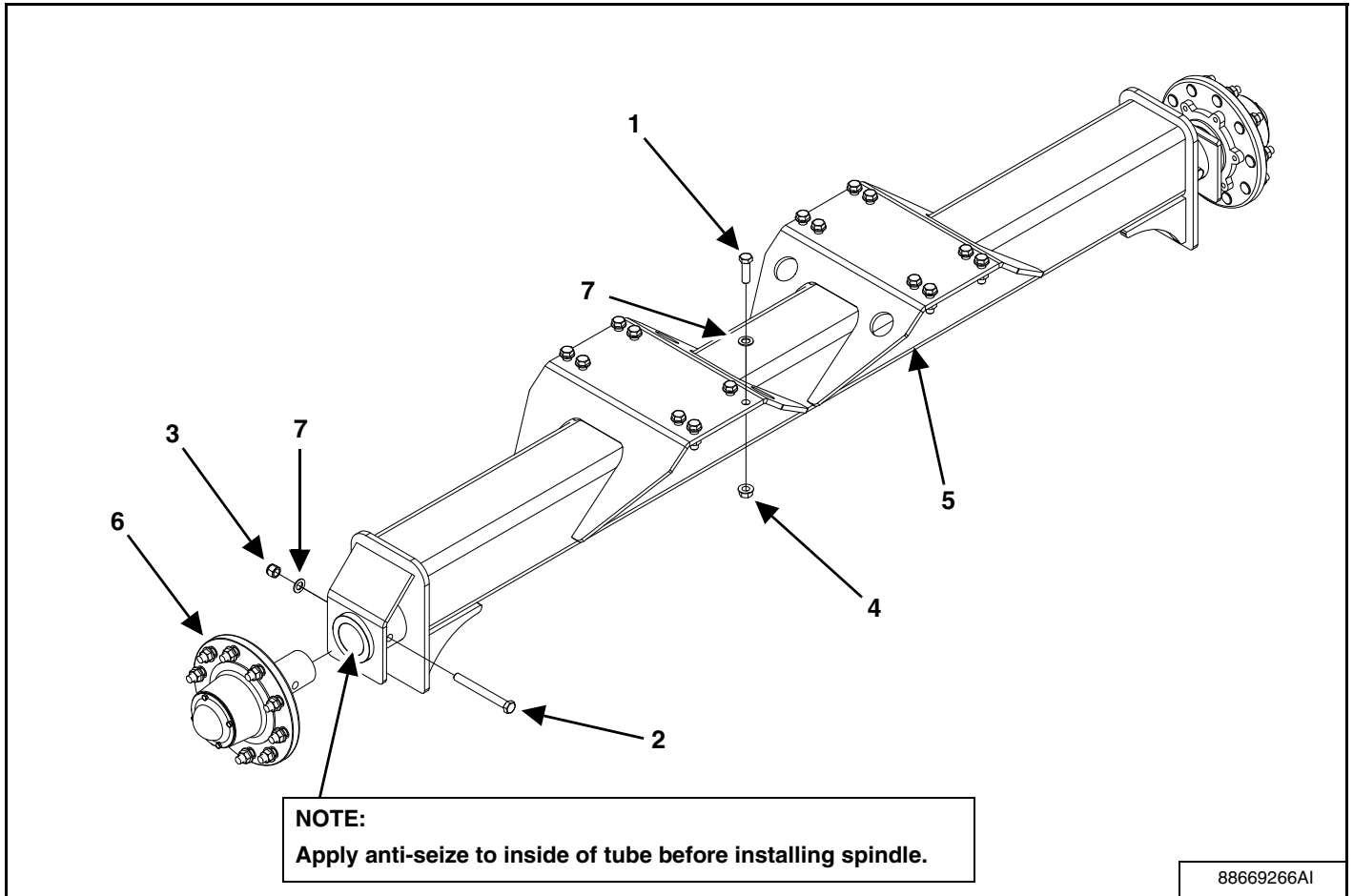

ITEM	PART NUMBER	DESCRIPTION	QTY
1	09706701	CSHH G5 P 0.75" x 2.50"	16
2	09846394	CSHH G8 P 0.75" x 7.50"	2
3	88660492	LOCKNUT, 3/4" NI GR5 YZ	2
4	88663904	NUT FLG, TP LCK, 3/4-10 GR5YZ	16
5	88669265	AXLE WELDMENT, GREEN	1
	88669264	AXLE WELDMENT, RED	1
6	88669387	HUB & SPINDLE ASSEMBLY 15K GREEN	2
	88669386	HUB & SPINDLE ASSEMBLY 15K RED	2
7	SXFW-075-SAE-YZ	FLATWASHER, 3/4" YLLW ZINC	18

SINGLE AXLE ASSEMBLY 132 IN.

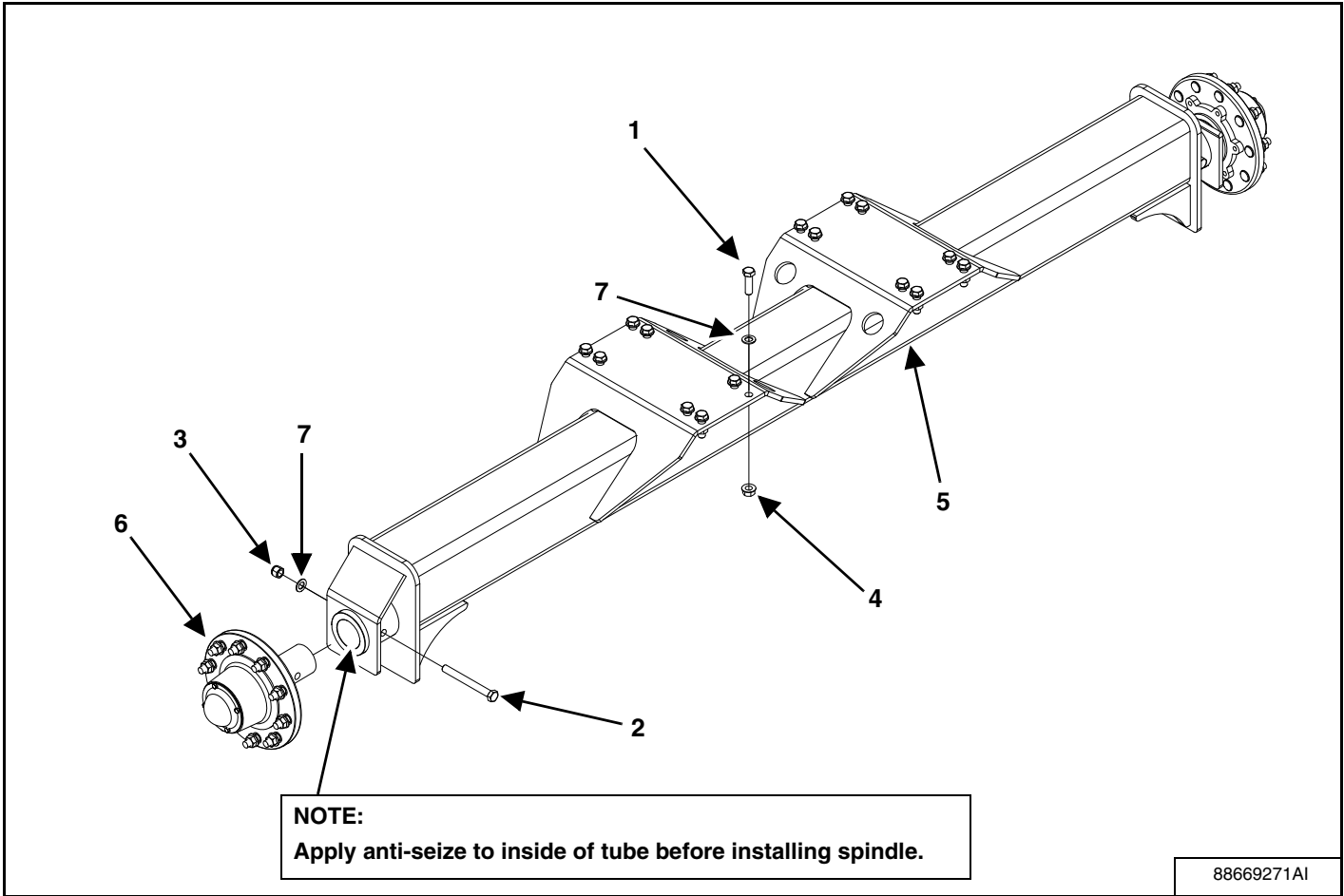

ITEM	PART NUMBER	DESCRIPTION	QTY
1	09706701	CSHH G5 P 0.75" x 2.50"	16
2	09846394	CSHH G8 P 0.75" x 7.50"	2
3	88660492	LOCKNUT, 3/4" NI GR5 YZ	2
4	88663904	NUT FLG, TP LCK, 3/4-10 GR5YZ	16
5	88669270	AXLE WELDMENT, GREEN	1
	88669269	AXLE WELDMENT, RED	1
6	88669387	HUB & SPINDLE ASSEMBLY 15K GREEN	2
	88669386	HUB & SPINDLE ASSEMBLY 15K RED	2
7	SXFW-075-SAE-YZ	FLATWASHER, 3/4" YLLW ZINC	18

ADJUSTABLE AXLE ASSEMBLY (OPTIONAL)

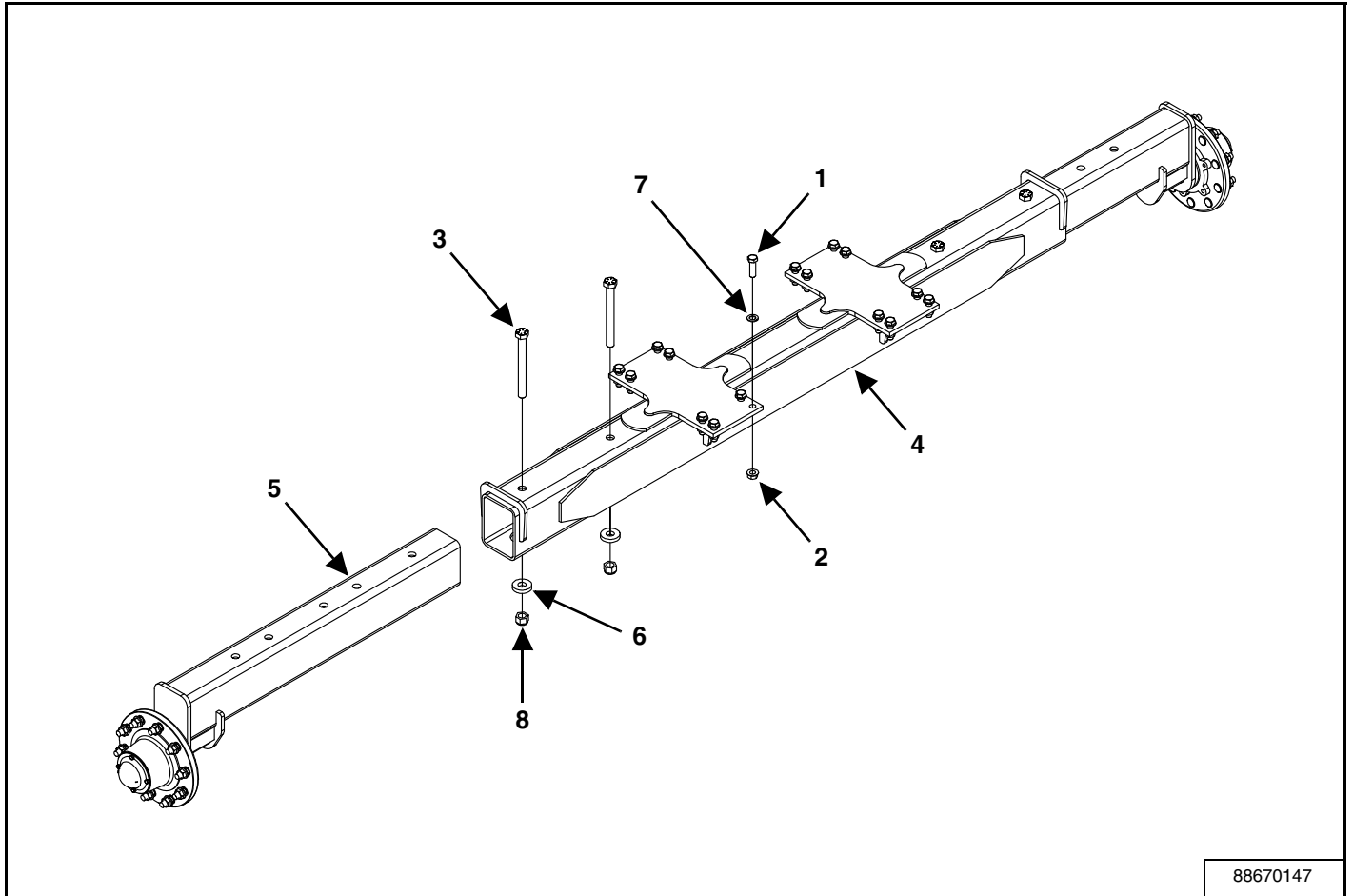

88670147

ITEM	PART NUMBER	DESCRIPTION	QTY
1	09706701	CSHH G5 P 3/4" x 2-1/2"	16
2	88663904	NUT FLG, TP LCK, 3/4-10 GR 5 YZ	16
3	88666423	BOLT, HEX; 1" x 9-1/2" GR 8 YZ	4
4	88670152	CENTER AXLE WELDMENT, GREEN	1
	88670151	CENTER AXLE WELDMENT, RED	1
5	88669270	1 DEGREE AXLE INSERT ASSEMBLY, GREEN	2
	88670153	1 DEGREE AXLE INSERT ASSEMBLY, RED	2
6	SX013733	WASHER, 2-1/2" x 1/2", 1.047" HOLE	4
7	SXFW-075-SAE-YZ	FLATWASHER, SAE 3/4" YLLW ZN	16
8	SXLN-100-NI-YZ	LOCKNUT, NYLON INSERT	4

DUAL AXLE ASSEMBLY - 20 / 22

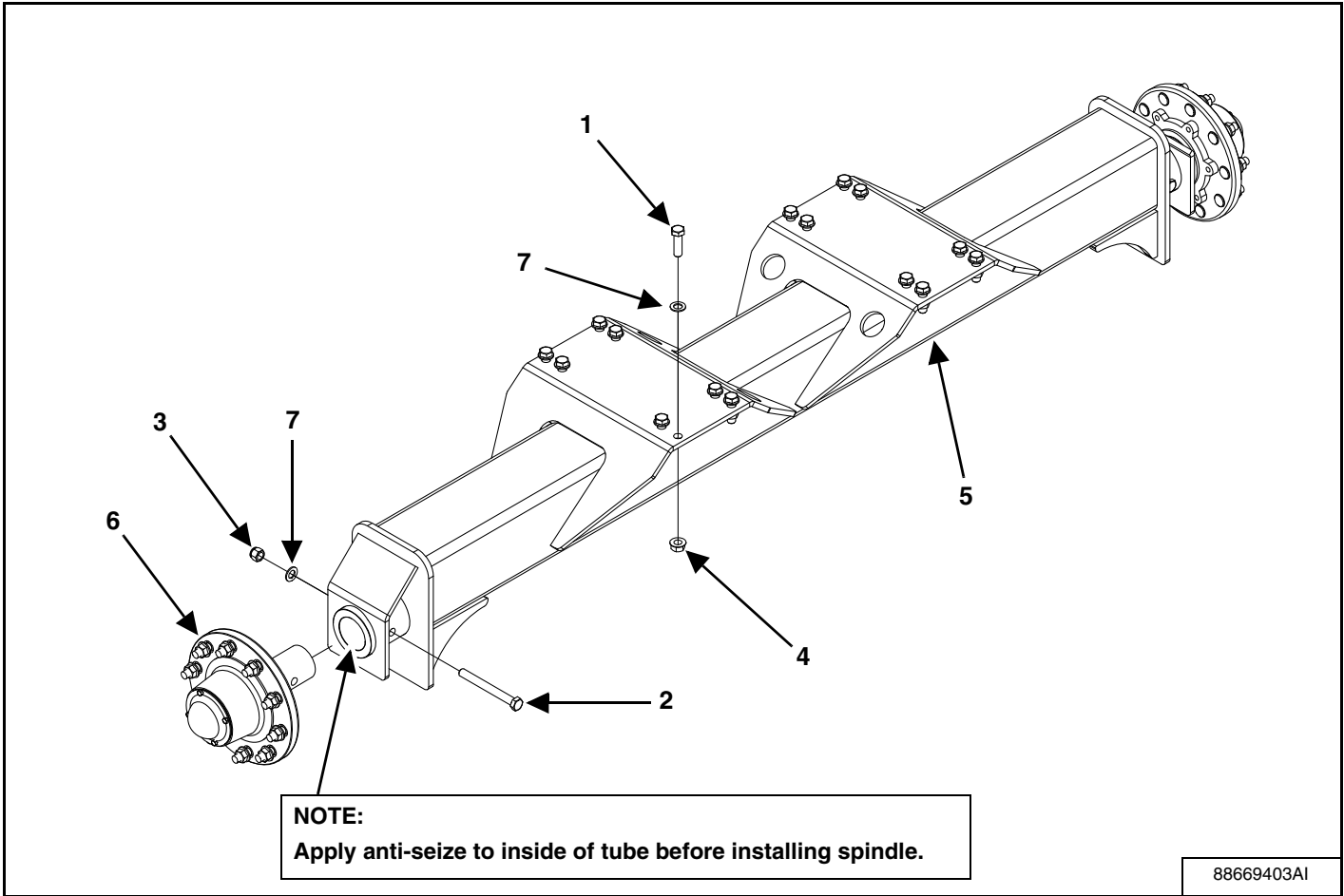

ITEM	PART NUMBER	DESCRIPTION	QTY
1	09706701	CSHH G5 P 0.75" x 2.50"	16
2	09846394	CSHH G8 P 0.75" x 7.50"	2
3	88660492	LOCKNUT, 3/4" NI GR5 YZ	2
4	88663904	NUT FLG, TP LCK, 3/4-10 GR5YZ	16
5	88669406	DUAL AXLE WELDMENT, GREEN	1
	88669405	DUAL AXLE WELDMENT, RED	1
6	88669387	HUB & SPINDLE ASSEMBLY 15K GREEN	2
	88669386	HUB & SPINDLE ASSEMBLY 15K RED	2
7	SXFW-075-SAE-YZ	FLATWASHER, 3/4" YLLW ZINC	18

DUAL AXLE ASSEMBLY - 30

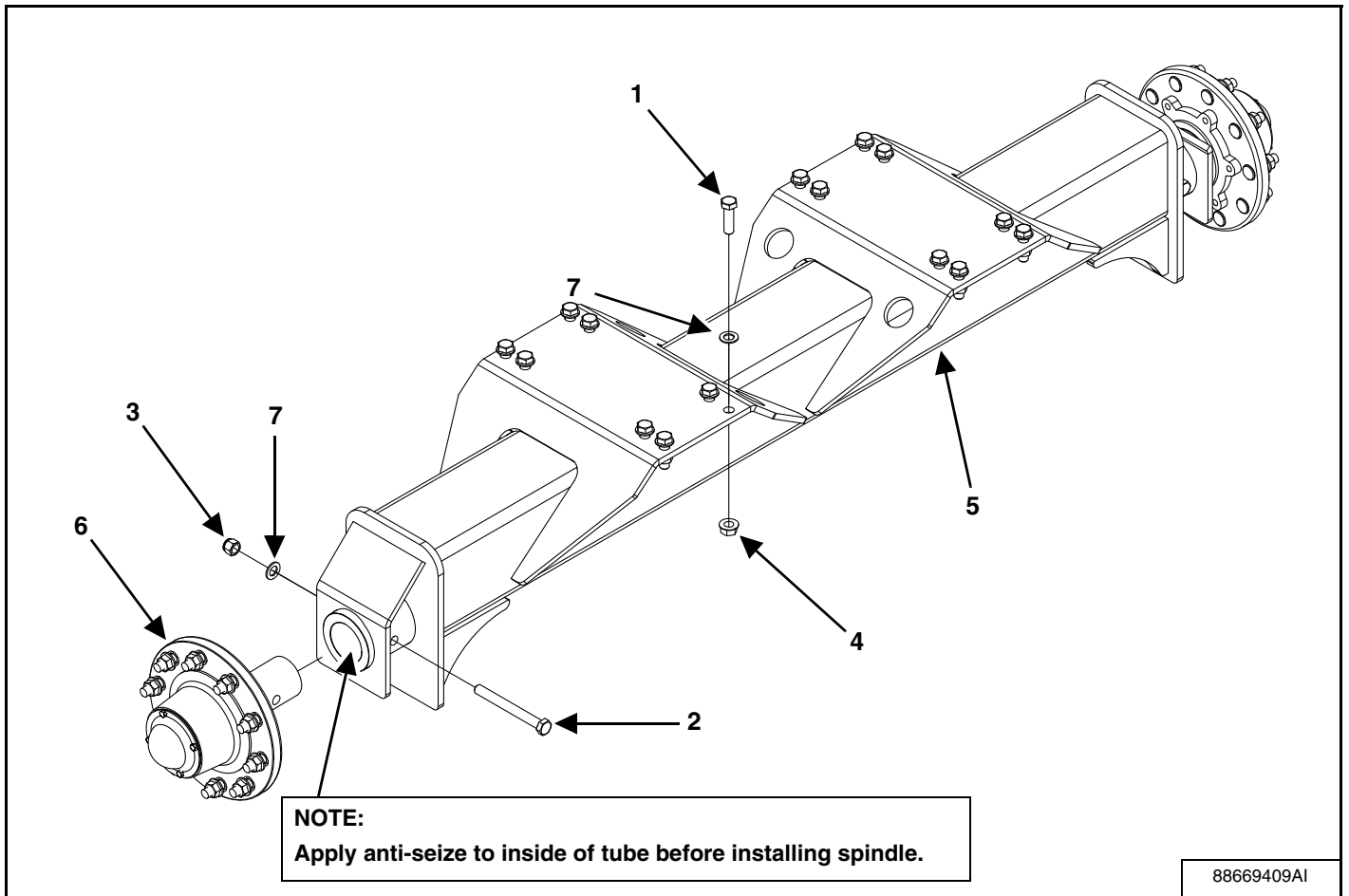

ITEM	PART NUMBER	DESCRIPTION	QTY
1	09706701	CSHH G5 P 0.75" x 2.50"	16
2	09846394	CSHH G8 P 0.75" x 7.50"	2
3	88660492	LOCKNUT, 3/4" NI GR5 YZ	2
4	88663904	NUT FLG, TP LCK, 3/4-10 GR5YZ	16
5	88669412	DUAL AXLE WELDMENT, GREEN	1
	88669411	DUAL AXLE WELDMENT, RED	1
6	88669387	HUB & SPINDLE ASSEMBLY 15K GREEN	2
	88669386	HUB & SPINDLE ASSEMBLY 15K RED	2
7	SXFW-075-SAE-YZ	FLATWASHER, 3/4" YLLW ZINC	18

DUAL AXLE ASSEMBLY - 38

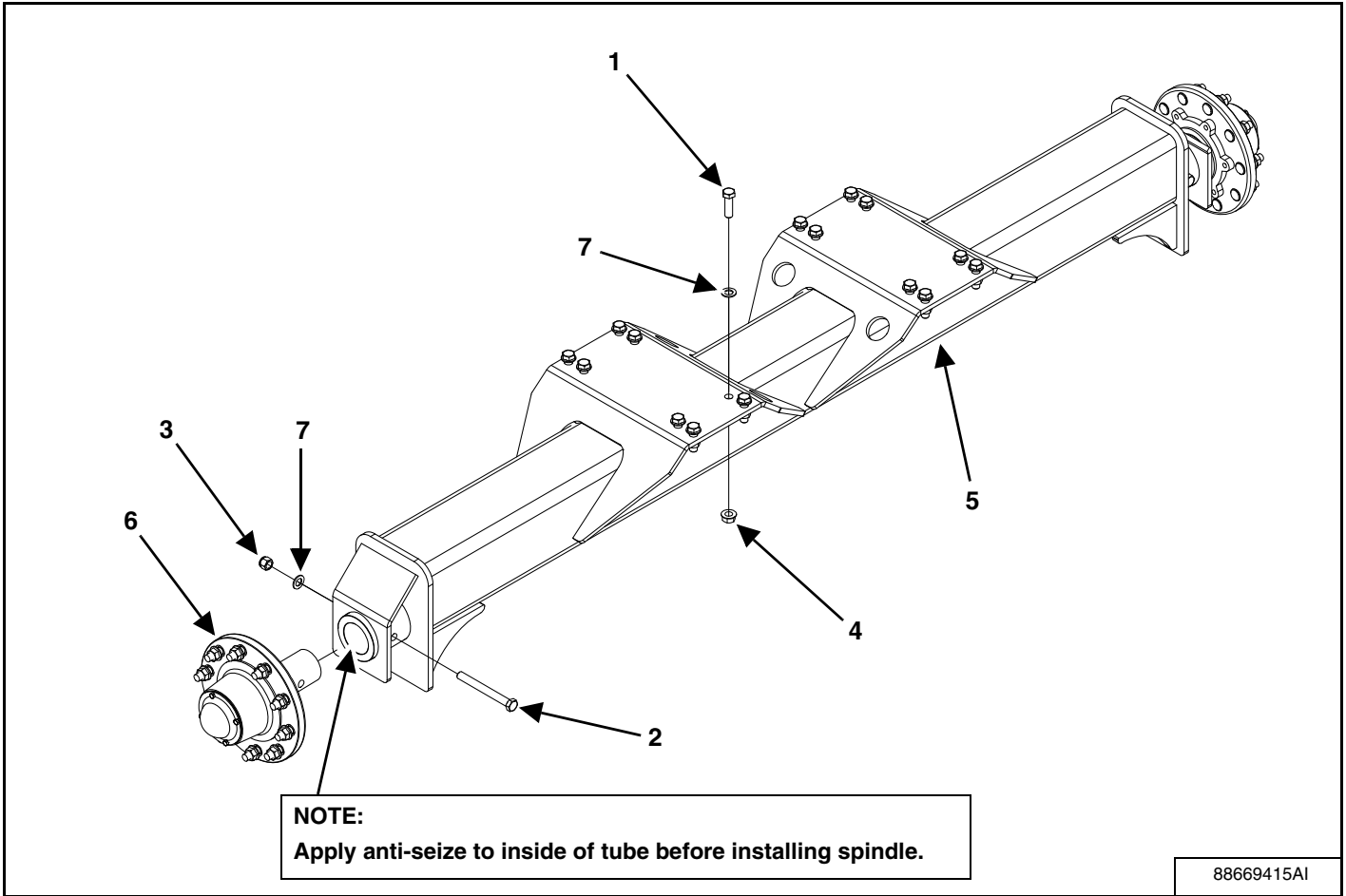

ITEM	PART NUMBER	DESCRIPTION	QTY
1	09706701	CSHH G5 P 0.75" x 2.50"	16
2	09846394	CSHH G8 P 0.75" x 7.50"	2
3	88660492	LOCKNUT, 3/4" NI GR5 YZ	2
4	88663904	NUT FLG, TP LCK, 3/4-10 GR5YZ	16
5	88669265	DUAL AXLE WELDMENT, GREEN	1
	88669264	DUAL AXLE WELDMENT, RED	1
6	88669387	HUB & SPINDLE ASSEMBLY 15K GREEN	2
	88669386	HUB & SPINDLE ASSEMBLY 15K RED	2
7	SXFW-075-SAE-YZ	FLATWASHER, 3/4" YLLW ZINC	18

HUB ASSEMBLY

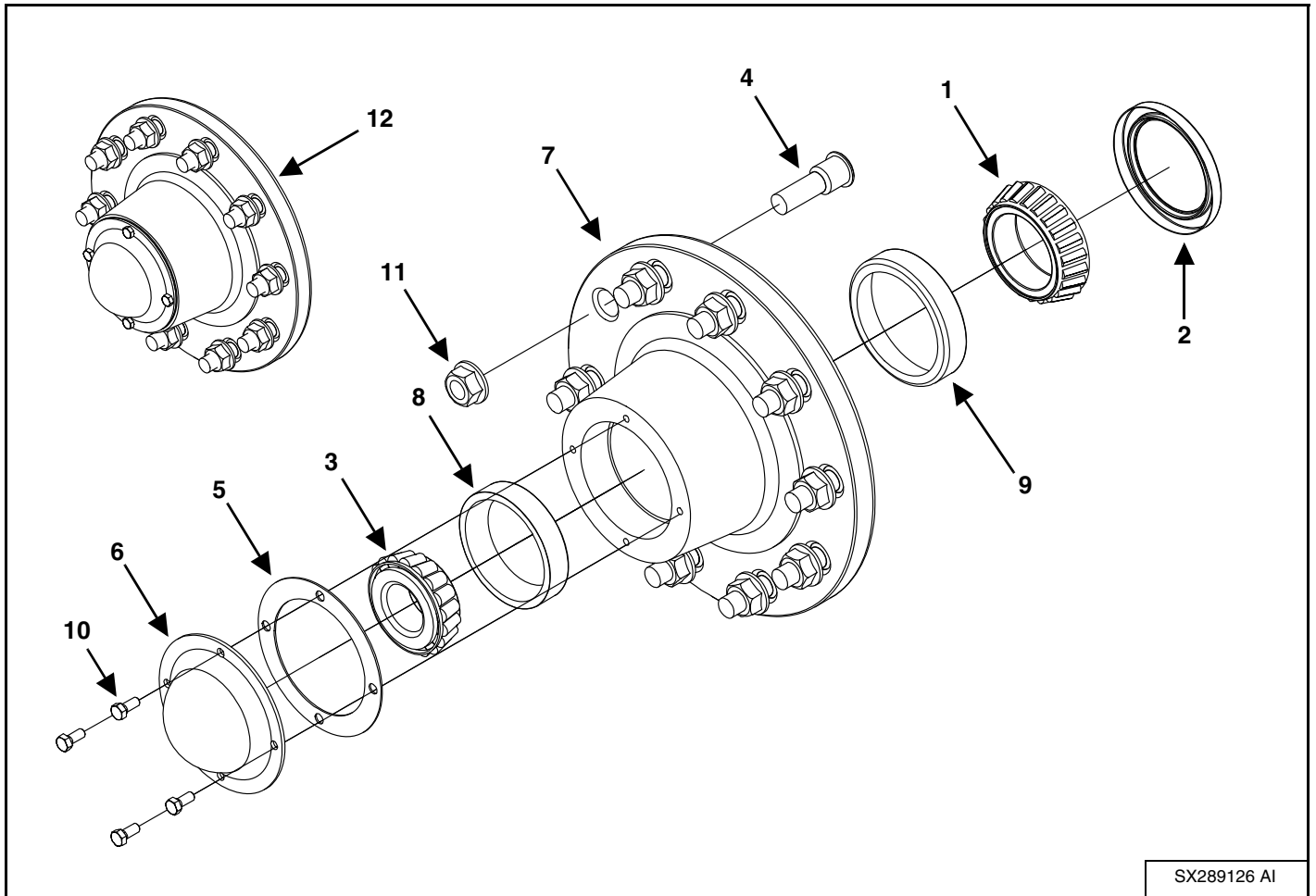

SX289126 AI

ITEM	PART NUMBER	DESCRIPTION	QTY
1	88665668	BEARING CONE	1
2	88665669	GREASE SEAL	1
3	88665670	OUTER CONE BEARING	1
4	88665671	WHEEL STUD	10
5	88665672	HUB CAP GASKET	1
6	88665673	HUB CAP	1
7	88665675	HUB, W/CUPS	1
8	88665676	OUTER CUP	1
9	88667979	BEARING CUP	1
10	SX905205	BOLT, DUST CAP	4
11	SX913571	WHEEL NUT, 3/4-16 FLANGED	10
12	88665690	COMPLETE 15000# HUB, GREEN	1
	88665689	COMPLETE 15000# HUB, RED	1

FRAME GROUP

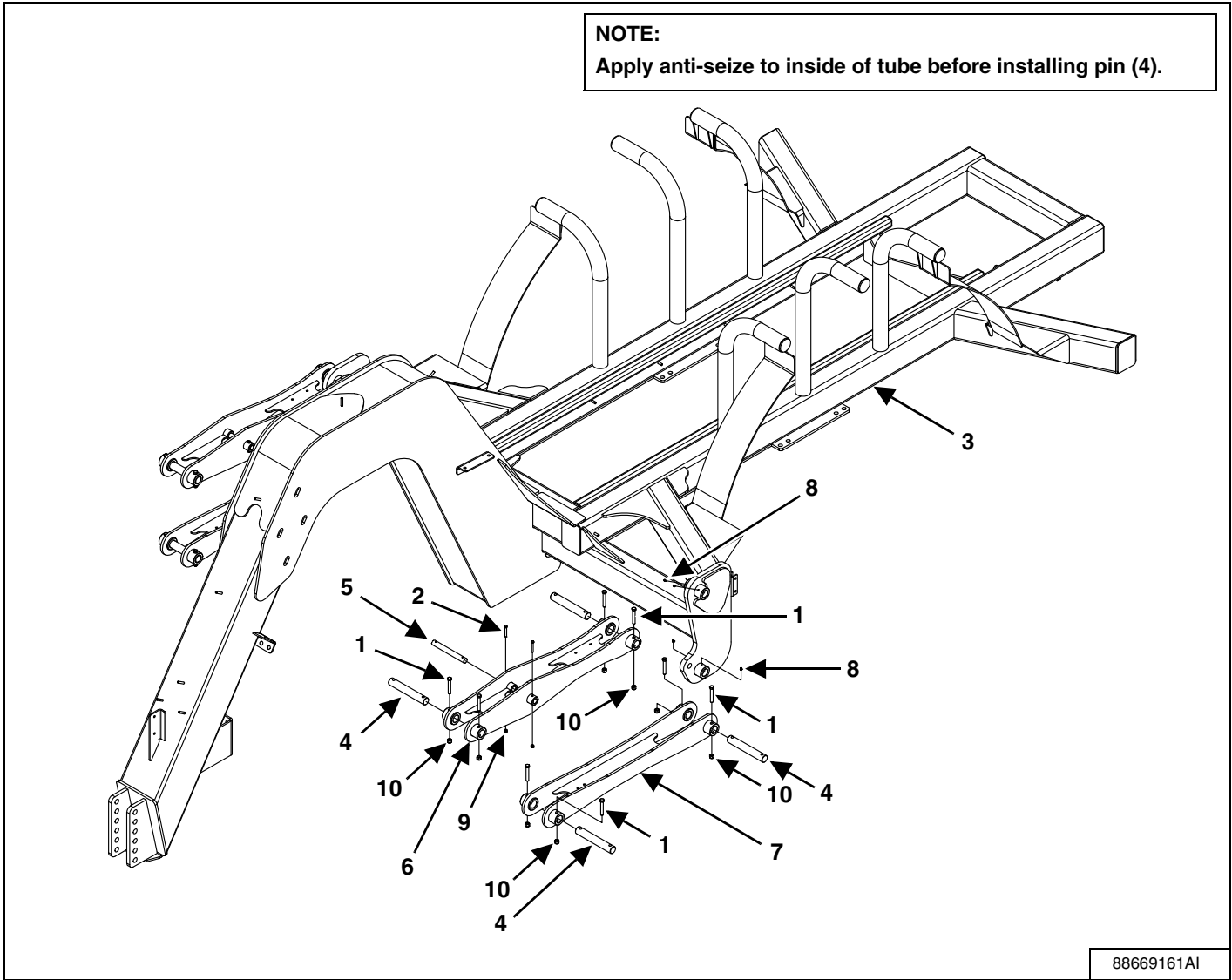

ITEM	PART NUMBER	DESCRIPTION	QTY
1	00088043	BOLT, 1/2" x 3-1/4" HEX G5 YZ	16
2	86505972	CSHH, 0.31" x 2-1/4" G5P 86505344	4
3	88669165	WELDMENT, MAIN FRAME, GREEN	1
	88669164	WELDMENT, MAIN FRAME, RED	1
4	88669208	PIN, PARALLEL ARM	8
5	88669212	CYLINDER PIN, PARALLEL ARM	2
6	88669286	WELDMENT, PARALLEL UPPER GREEN	2
	88669285	WELDMENT, PARALLEL UPPER RED	2
7	88669289	WELDMENT, PARALLEL LOWER GREEN	2
	88669288	WELDMENT, PARALLEL LOWER RED	2
8	SXG1641	GREASE ZERK, 1/4"-28 STRAIGHT	8
9	SXLN-031-NIYZ	LOCKNUT, 5/16" NYLON INSERT YZ	4
10	SXLN-050-NI-YZ	2" NYLON INSERT YZ	16

HITCH GROUP

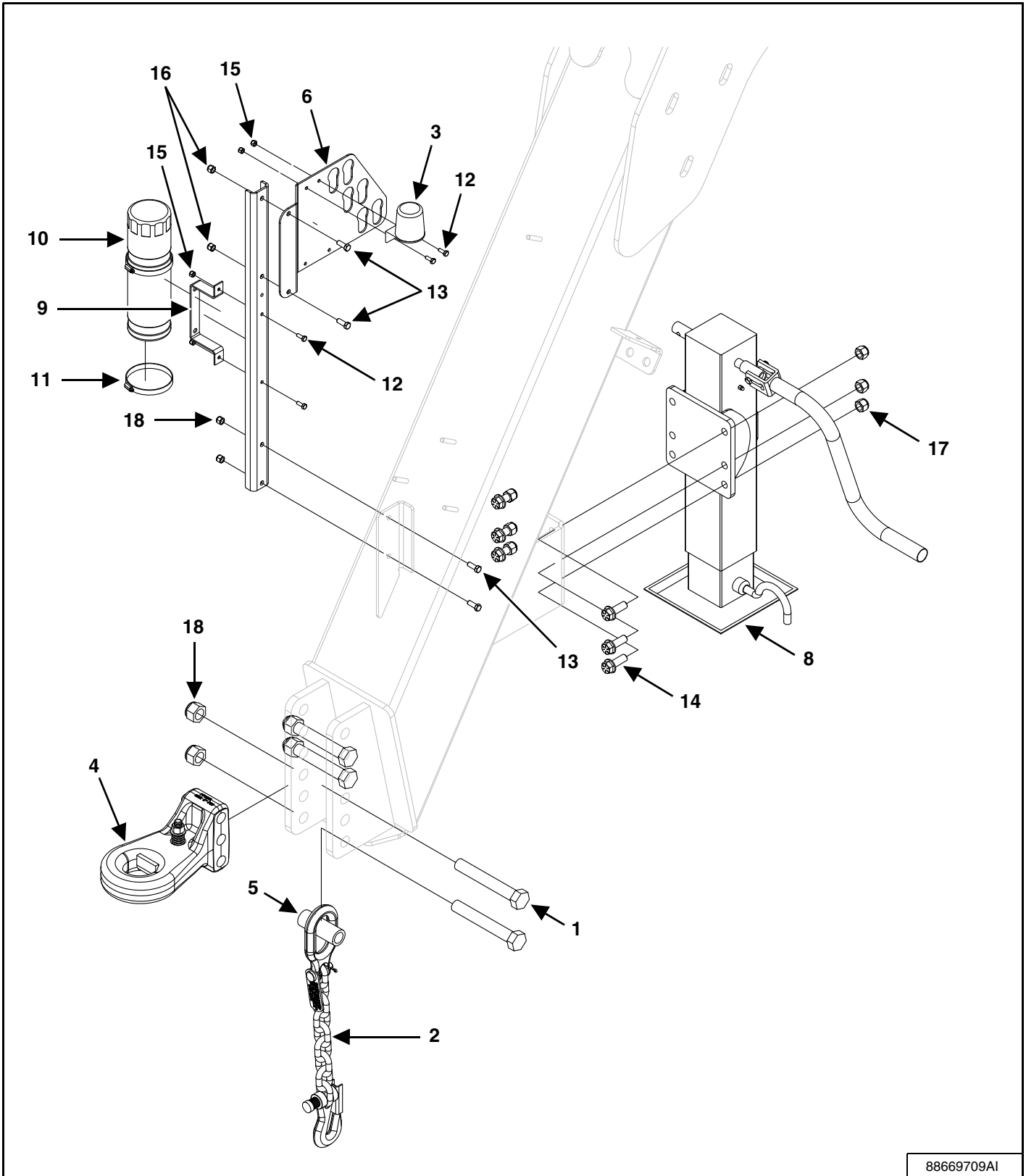

88669709AI

ITEM	PART NUMBER	DESCRIPTION	QTY
1	09602223	BOLT, CSHH G5 P 1" x 7"	4
2	88660499	AG SAFETY CHAIN, 40,000 LB	1
3	88660521	ELECTRICAL PLUG HOLDER	1
4	88661392	PINTLE HITCH, CAT. 4-5 CRSSOVR	1
5	88663962	SAFETY CHAIN TUBE	1
6	88664974	HYDRAULIC HOSE RACK	1
7	88666610	CHANNEL - FORMED MANUAL	1
8	88669186	JACK WELDMENT	1
9	SX006069	STRAINER FLANGED MOUNT	1
10	SX013049	PLASTIC MANUAL, PAK 3-11/16" OD	1
11	SX64J	WORM SCREW HOSE CLAMP, 4"	2
12	SXBH0250758YZ	BOLT, 1/4" x 3/4" GR 8	4
13	SXBH0381005YZ	BOLT, 3/8" x 1" YLLW ZNC	4
14	SXBHF0621758YZ	BOLT, 5/8" x 1-3/4" FLG GR 8 YZ	6
15	SXLN-025-NIYZ	LOCKNUT, 1/4" NYLON INSERT	4
16	SXLN-038-NIYZ	LOCKNUT, 3/8" NYLON INSERT YZ	4
17	SXLN-062-NI-YZ	LOCKNUT, 5/8" NYLON INSERT YZ	6
18	SXLN-100-NI-YZ	LOCKNUT, 1" NYLON INSERT	4

TANK SUPPORT

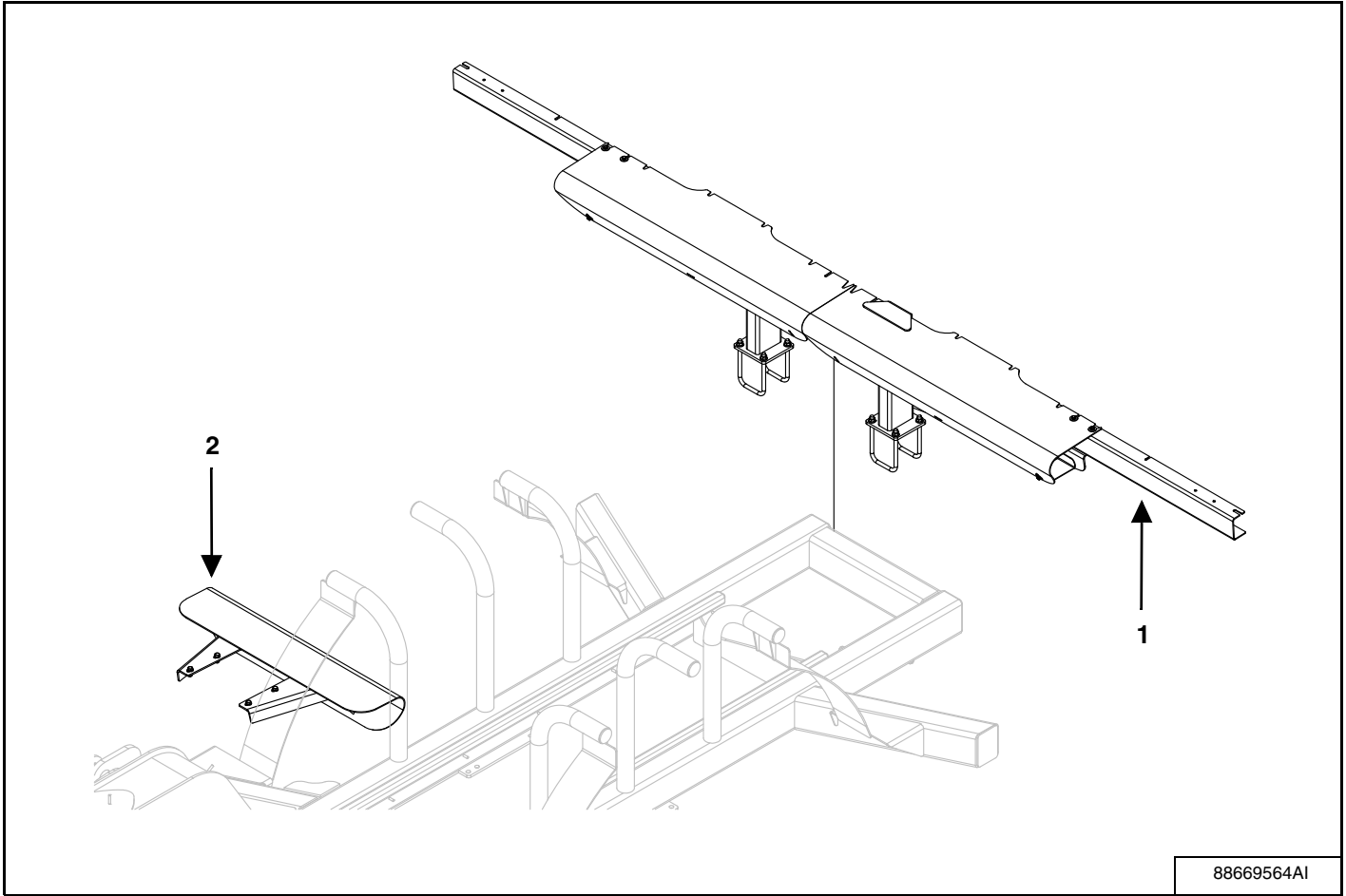

ITEM	PART NUMBER	DESCRIPTION	QTY
1	88666943	TANK SUPPORT ASSEMBLY REAR, GREEN	1
	88666944	TANK SUPPORT ASSEMBLY REAR, RED	1
2	88669657	TANK SUPPORT ASSEMBLY FRONT, GREEN	1
	88669656	TANK SUPPORT ASSEMBLY FRONT, RED	1

TANK SUPPORT FRONT

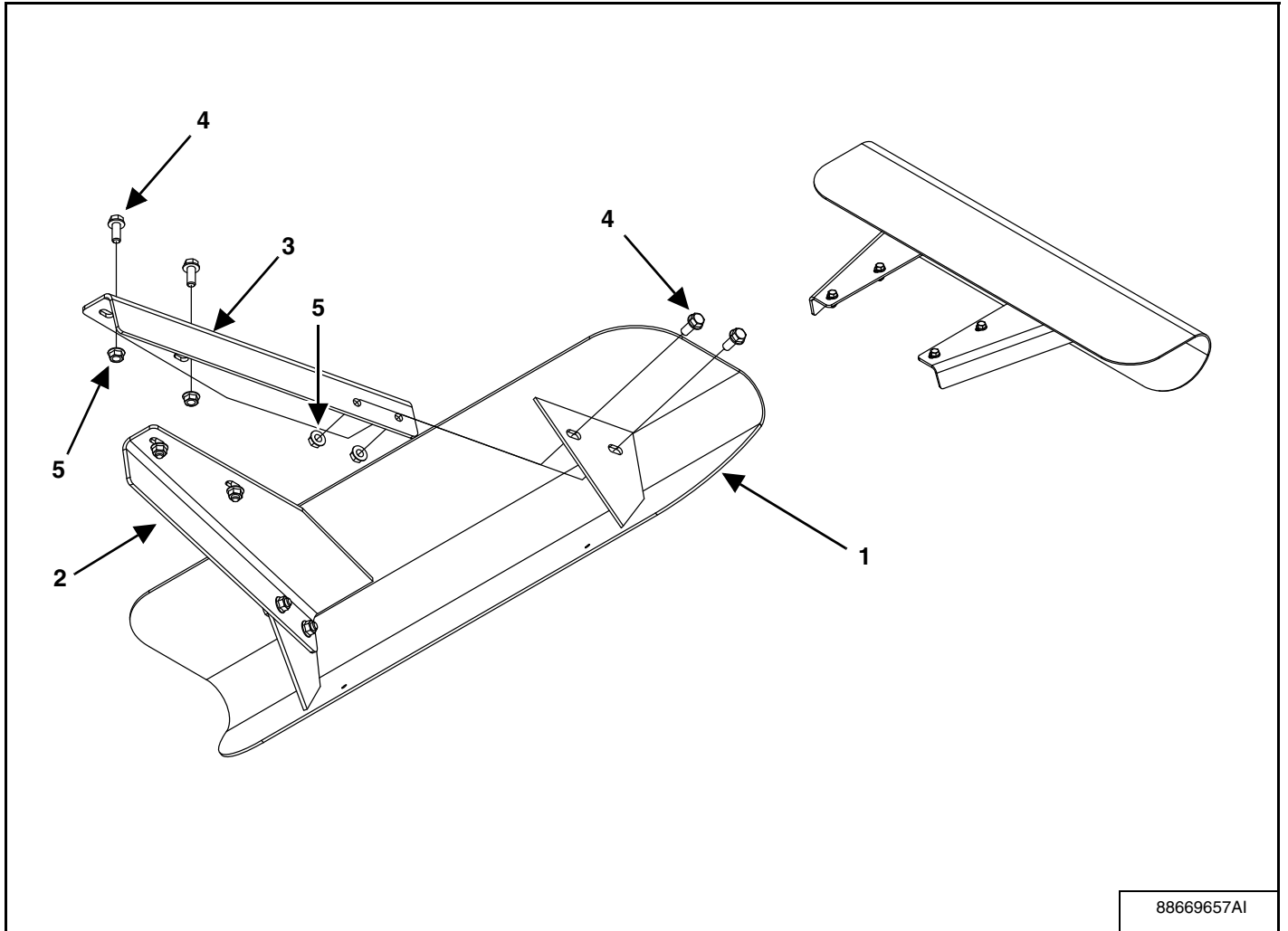

ITEM	PART NUMBER	DESCRIPTION	QTY
1	88669482	WELDMENT, TANK SUPPROT, FRONT GREEN	1
	88669477	WELDMENT, TANK SUPPROT, FRONT RED	1
2	88669659	PLATE, TANK SUPPORT, FORMED RH, GREEN	1
	88669658	PLATE, TANK SUPPORT, FORMED RH, RED	1
3	88669661	PLATE, TANK SUPPORT, FORMED LH, GREEN	1
	88669660	PLATE, TANK SUPPORT, FORMED LH, RED	1
4	SXBHF0501258YZ	BOLT, 1/2" x 1-1/4" FLG GR 8 YLLW ZN	8
5	SXNTFTL050138Y	TOP LOCK, 1/2"-13 GR 8	8

TANK SUPPORT REAR

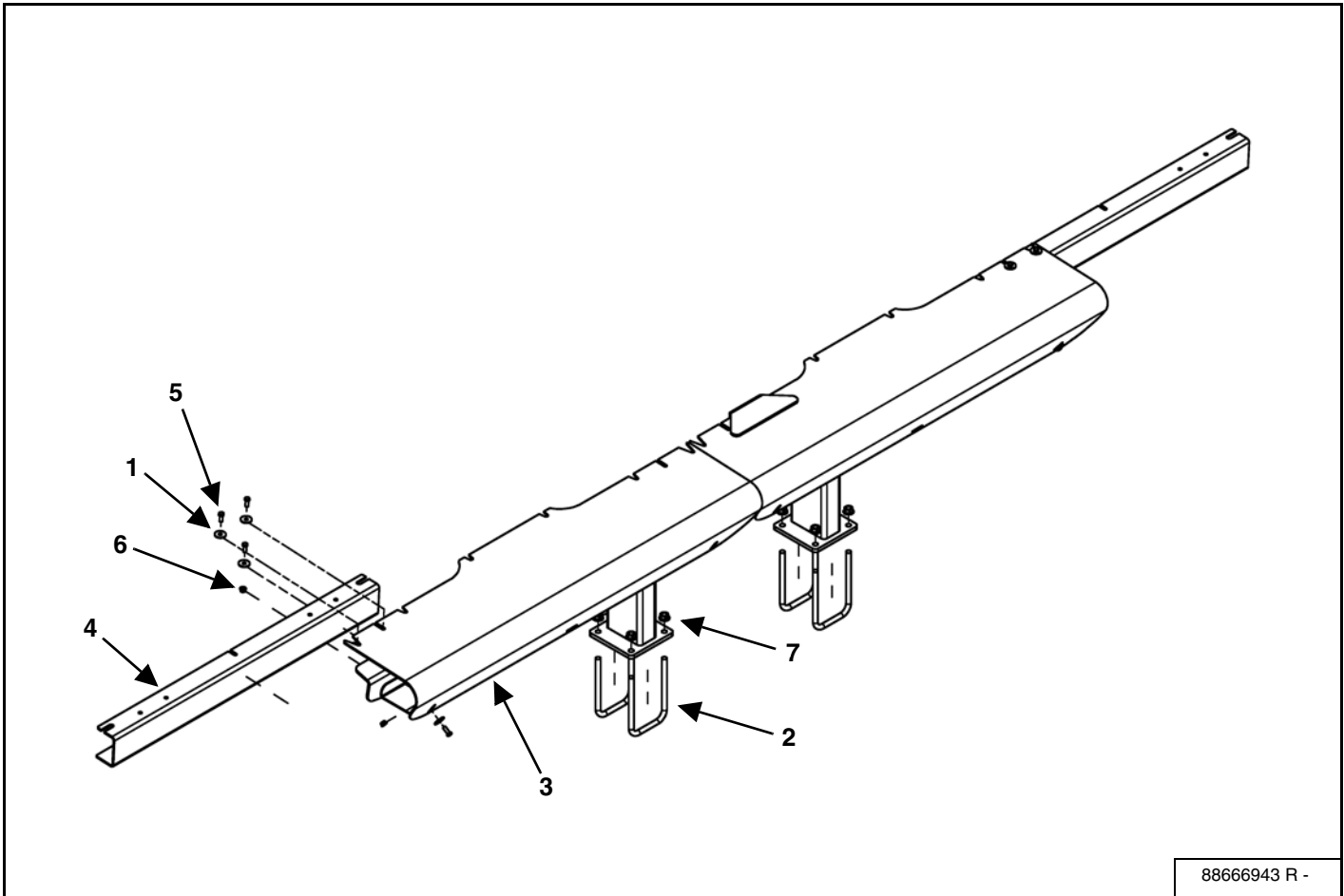

ITEM	PART NUMBER	DESCRIPTION	QTY
1	86505938	WASHER P, 0.406" ID, 1.375" OD, 0.083"	8
2	88663622	U-BOLT, 0.63" x 5.13" x 8.63" LG	4
3	88663906	WELDMENT, TANK SUPPORT REAR - GREEN	1
	88663905	WELDMENT, TANK SUPPORT REAR - RED	1
4	88664833	BRACKET, LIGHT BAR, GREEN	2
	88664831	BRACKET, LIGHT BAR, RED	2
5	SXBH0381005YZ	BOLT, 3/8" x 1" YZ	8
6	SXNTFTL038168YZ	NUT FLG, TP LCK, 3/8" GR8 YZ	8
7	SXNTFTL062118Y	NUT FLG, TP LCK, 5/8" GR8 YZ	8
NS	SX21294	MOUNT, CABLE TIE HEAVY DUTY	8

TANK ASSEMBLY

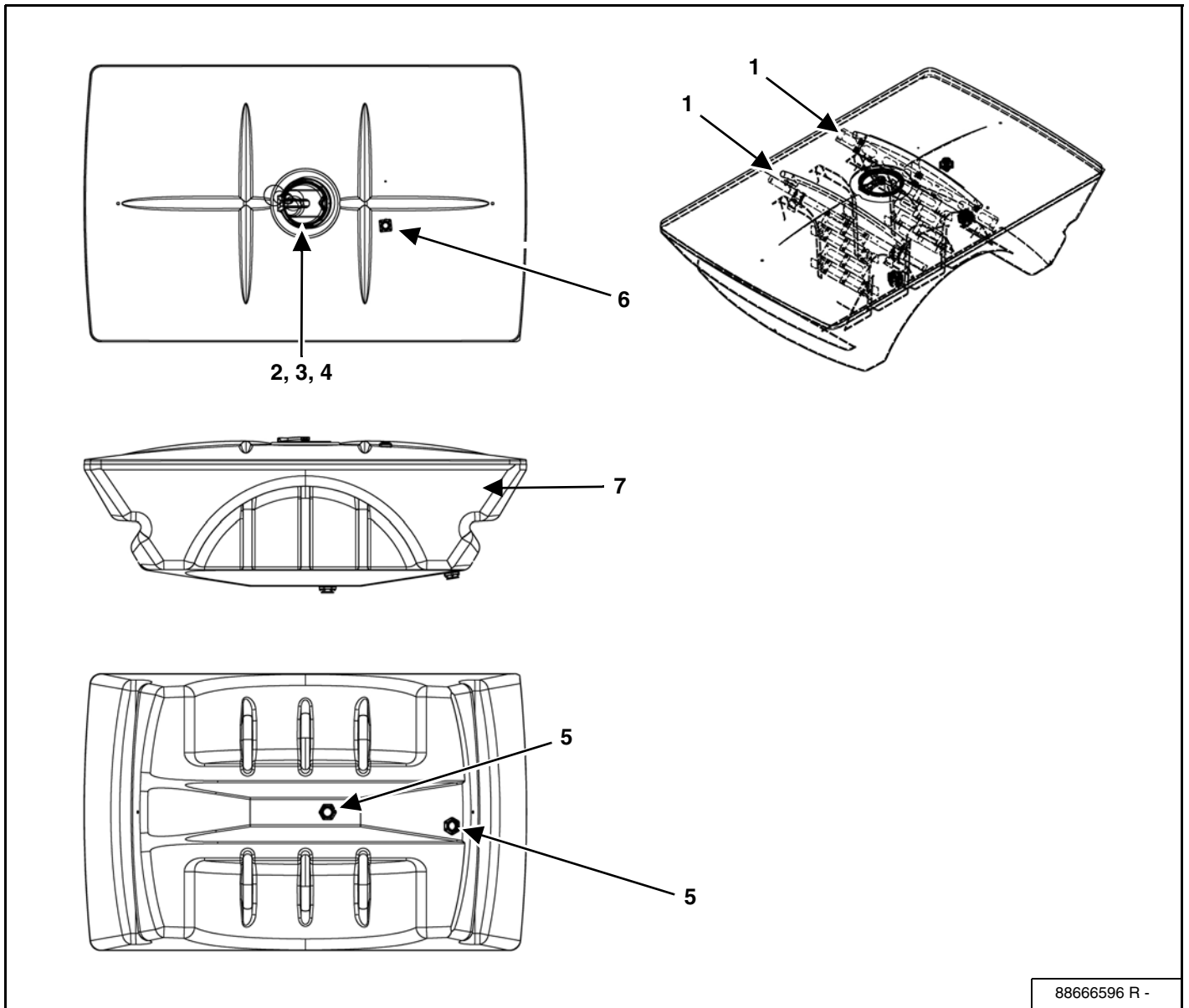

88666596 R -

ITEM	PART NUMBER	DESCRIPTION	QTY
1	88666618	TANK BAFFLE ASSEMBLY 1800	2
2	88664553	LID TANK 16" POLY	1
3	88664555	STSTPH#10-24 x 0.625 86505618	8
4	88664554	GASKET LID TANK 16" POLY	1
5	SXMBF300BD	BULKHEAD, 3", BOLT, FLANGED, BD	2
6	SXMBF220	MANIFOLD, 2" FP FLG, 2" FPT	1
7	88663650	TANK - 1800 GAL CREAM	1

TANK BAFFLE GROUP

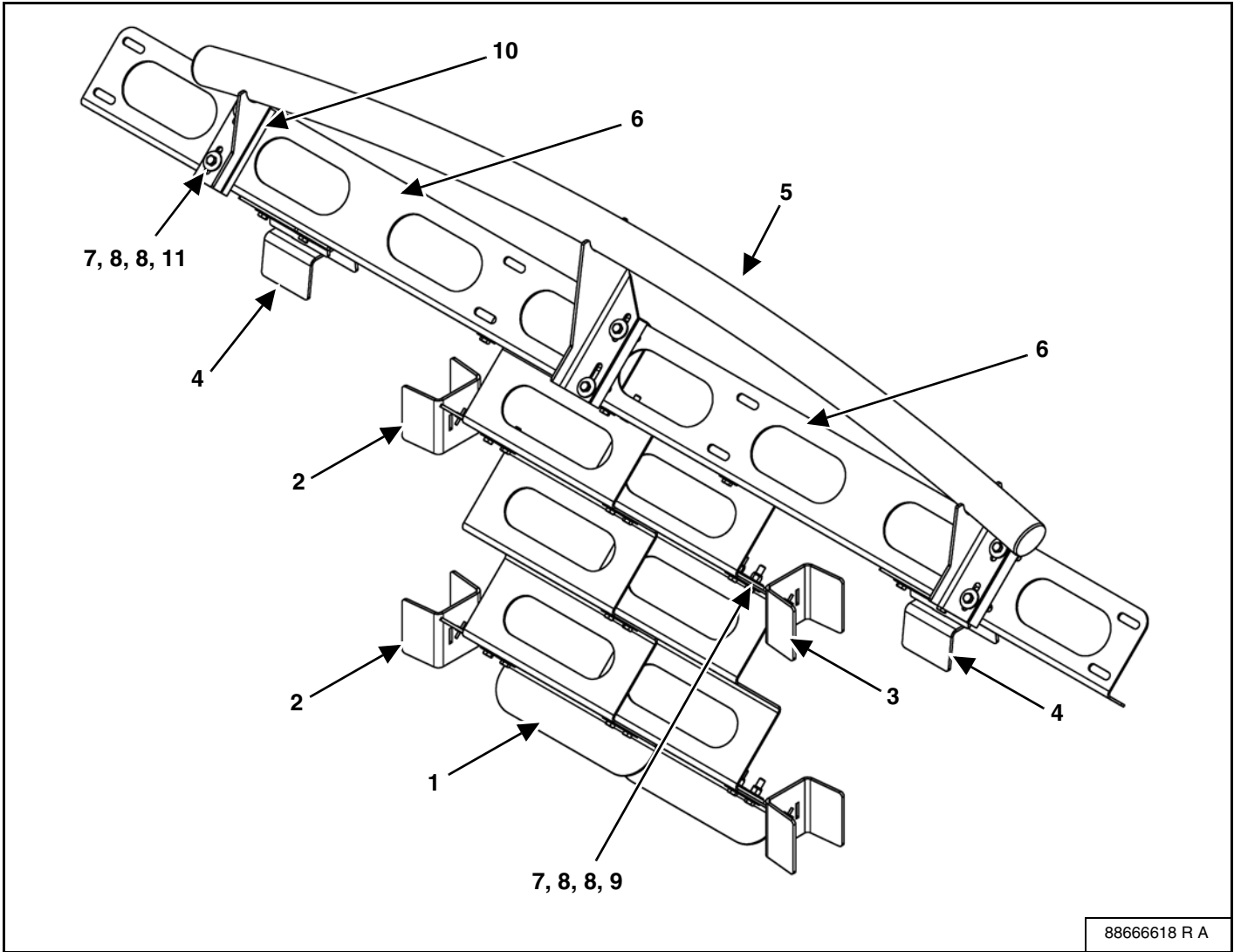

88666618 R A

ITEM	PART NUMBER	DESCRIPTION	QTY
1	88663784	BRACKET, BAFFLE LOWER SECT	2
2	88663787	BAFFLE CHANNEL LH WELDMENT	2
3	88663788	BAFFLE CHANNEL RH WELDMENT	2
4	88663802	RIB ADJUSTMENT WELDMENT	2
5	88663809	TANK RIB WELDMENT	1
6	88663789	BRACKET, UPPER BAFFLE 1800	2
7	88663814	LOCKNUT, 3/8" NYLON INSERT SS	28
8	88663813	WASHER, FENDER 3/8" STAINLESS	56
9	88663812	BOLT, 3/8" x 1.50" UNC SS	28
10	88666501	BAFFLE SPACER PLATE	3
11	88667240	BOLT, 3/8" x 2 1/2" UNC SS	6

SIGHT GAUGE ASSEMBLY

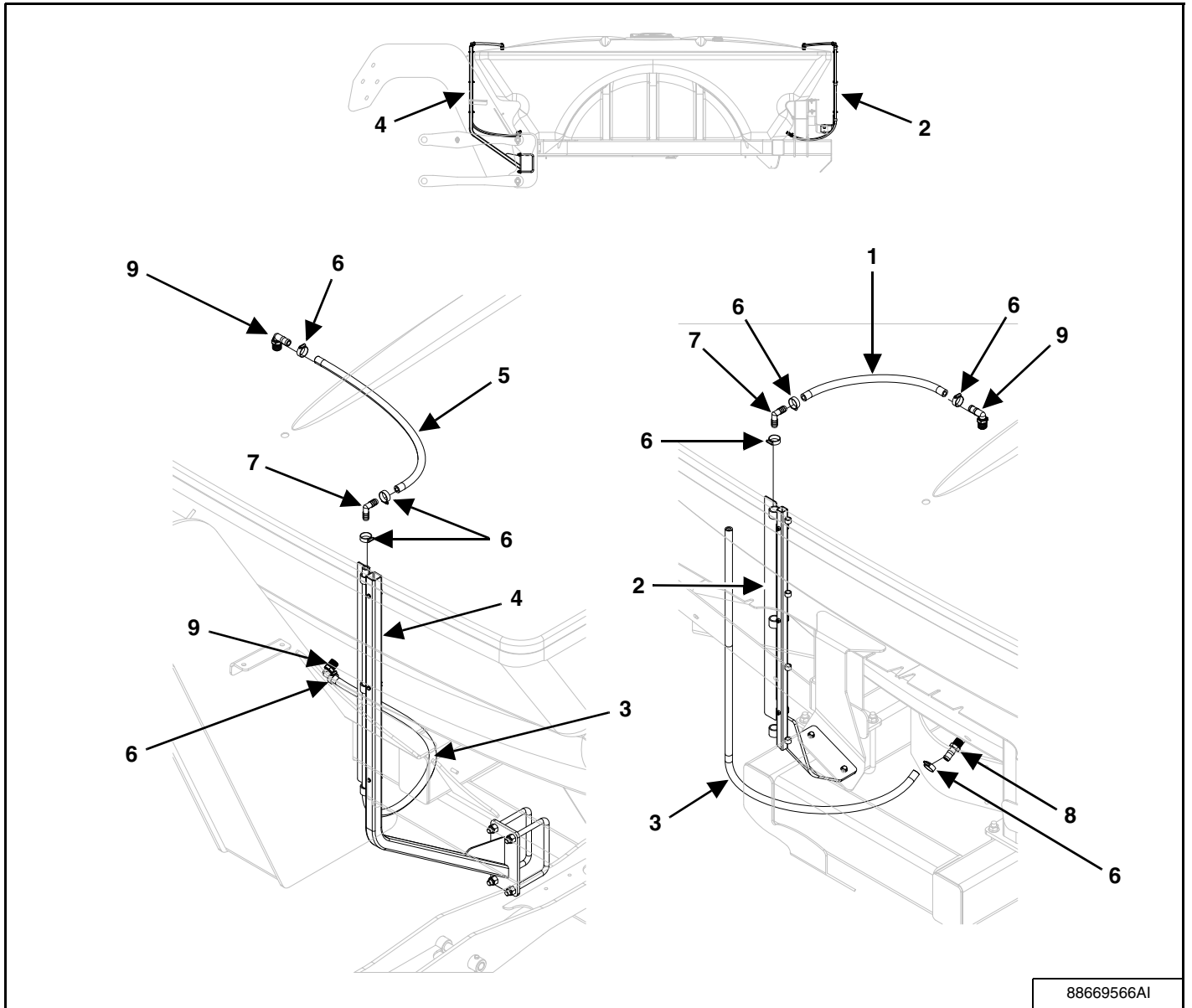

88669566AI

ITEM	PART NUMBER	DESCRIPTION	QTY
1	88664857	HOSE, SIGHT 3/4"	1
2	88666829	SIGHT GAUGE ASSEMBLY, 1860	1
3	88666958	HOSE, SIGHT 3/4"	2
4	88669194	1840 FRONT SIGHT GAUGE ASSEMBLY	1
5	88669570	HOSE, SIGHT 3/4"	1
6	SX12J	WORM SCREW HOSE CLAMP, 3/4"	8
7	SX3EL34HB	HOSE FITTING, 5/8" EL HB x 5/8" HB	2
8	SXHB-075	HOSE BARB, 3/4" MPT x 3/4" HB POLY	1
9	SXHB-075-90	HOSE BARB, 3/4" MPT x 3/4" HB EL	3

FRONT SIGHT GAUGE

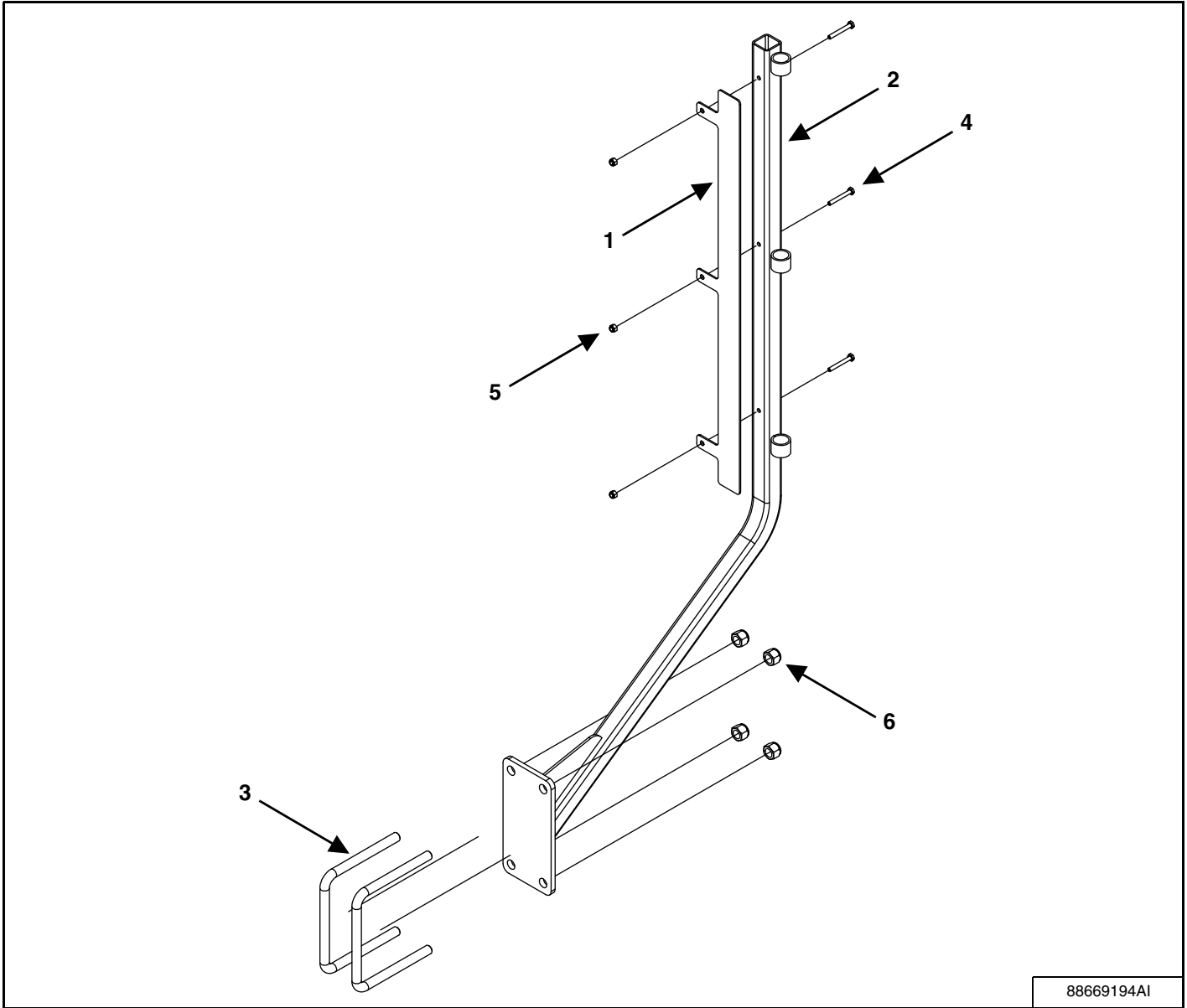

88669194AI

ITEM	PART NUMBER	DESCRIPTION	QTY
1	88666825	SIGHT GAUGE DECAL PLATE, 1860	1
2	88669191	FRONT SIGHT GAUGE WELDMENT	1
3	88669377	U-BOLT, 5/8" x 7" x 6-1/2" GR 5 SQ YZ	2
4	SXBH0252005YZ	BOLT, 1/4" x 2" BOLTS GR 5	3
5	SXLN-025-NIYZ	LOCKNUT, 1/4" NYLON INSERT	3
6	SXLN-062-NI-YZ	LOCKNUT, 5/8" NYLON INSERT YZ	4

REAR SIGHT GAUGE

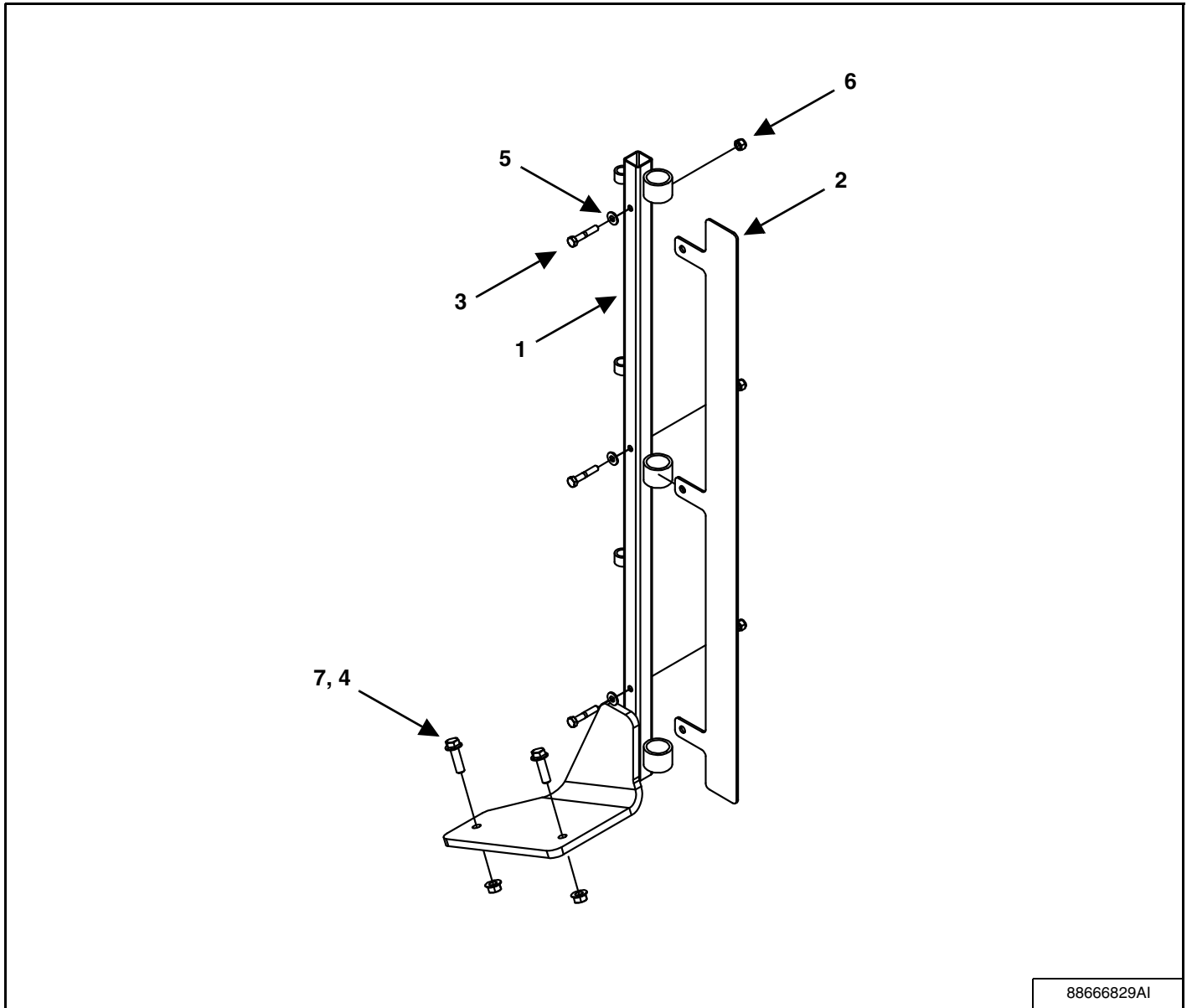

88666829AI

ITEM	PART NUMBER	DESCRIPTION	QTY
1	88666827	SIGHT GAUGE WELDMENT	1
2	88666825	SIGHT GAUGE, DECAL PLATE, 1860	1
3	SXBH-025-150-5	BOLT; 1/4" x 1-1/4" GR 5 ZINC	3
4	SXBHF0381258YZ	BOLT, FLG, 3/8" x 1-1/4" GR 8 YLLWZN	2
5	SXFW-025-YZ	FLATWASHER, 1/4" ZINC PLATED	3
6	SXLN-025-NIYZ	LOCKNUT, 1/4" NYLON INSERT	3
7	SXNTFTL038168YZ	NUT FLG, 3/8" TP LCK, 3/8" GR 8 YZ	2

HAND / EYE WASH GROUP

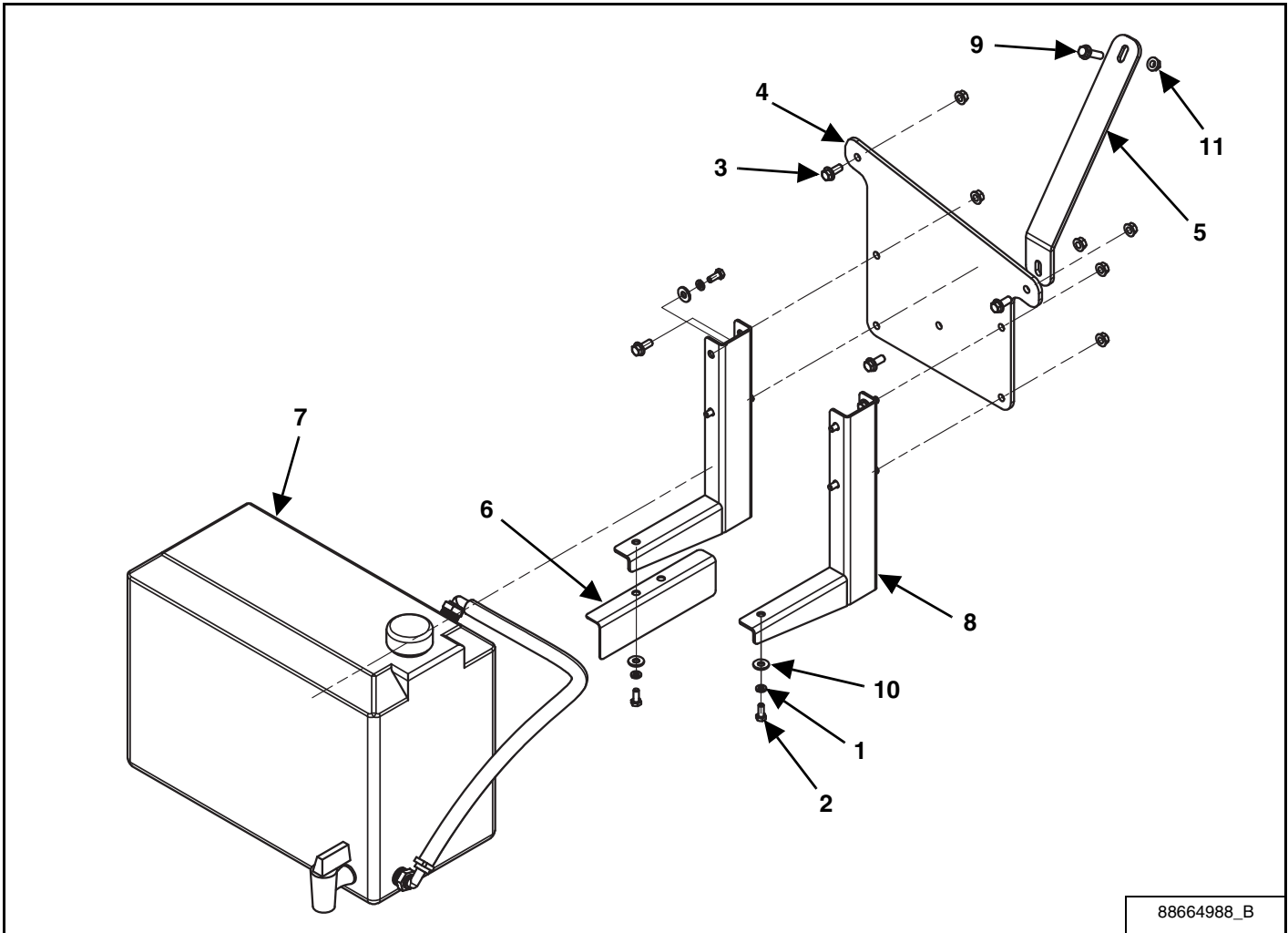

88664988_B

ITEM	PART NUMBER	DESCRIPTION	QTY
1	00080681	WASHER LOCK, 0.31" PL	6
2	00087872	BOLT, 0.31" x 3/4" HEX GR 5 PL	6
3	88662129	BOLT, FLANGE; 3/8" x 1" GR 5	7
4	88664963	PLATE MOUNT HAND TANK	1
5	88664964	PLATE BRACKET HAND TANK	1
6	88664965	SHEET MOUNT DECAL	1
7	88665010	HAND EYE RINSE TANK ASSEMBLY - CREAM	1
8	SX014666	WELDMENT; BRACKET, 9 GAL. TANK	2
9	SXBHF0381508YZ	BOLT; FLG, 3/8" x 1-1/2" GR 8 YLLWZN	1
10	SXFW-031-YZ	WASHER, FLAT, 5/16" YZ	6
11	SXNTFTL038168YZ	NUT FLG, TP LCK, 3/8"-16 UNC GR 8YZ	8

HAND / EYE WASH TANK ASSEMBLY (CREAM)

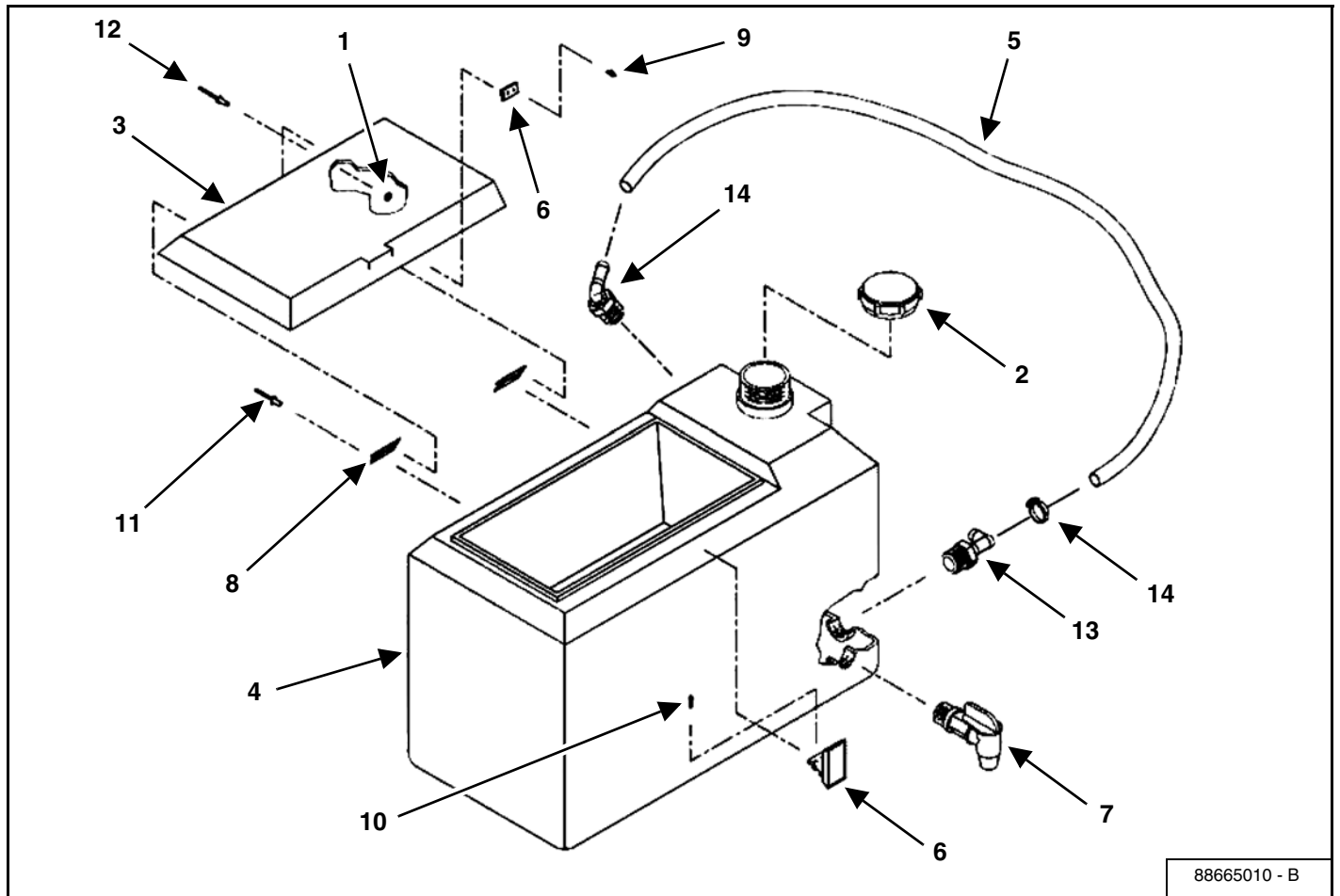

88665010 - B

ITEM	PART NUMBER	DESCRIPTION	QTY
1	88664993	RIVET WASHER, 3/8" OD x 3/16" ID	4
2	88664994	COVER, 9 GA TANK SCREW CAP	1
3	88664995	LID, 9 GAL TANK MOLDED	1
4	88665008	TANK, 9 GAL BUHLER CREAM	1
5	88665019	HOSE, 1/2" ID x 1/8" WALL SIGHT	1
6	88664997	LATCH, 07-10-201-12 LIVING BLK	1
7	88664998	SPIGOT, MATURAL 3/4"	1
8	88664999	HINGE, BUTT H03-30200-171 ZINC	2
9	88665000	RIVET, AB4-6A	2
10	88665001	RIVET, DRIVE 1/8" x 0.359 - 0.391	2
11	88665002	RIVET; 3/16" x AD64 - AH CLOSED	4
12	88665003	RIVET; 3/16" x 0.440 LG DOMEHEAD	4
13	88665005	HOSE FITTING, 3/4" MPT x 1/2" HB	2
14	88665006	CLAMP, SPEEDY FITS 1/2" HOSE	1

TOOLBAR ASSEMBLY (325 / 370 IN.)

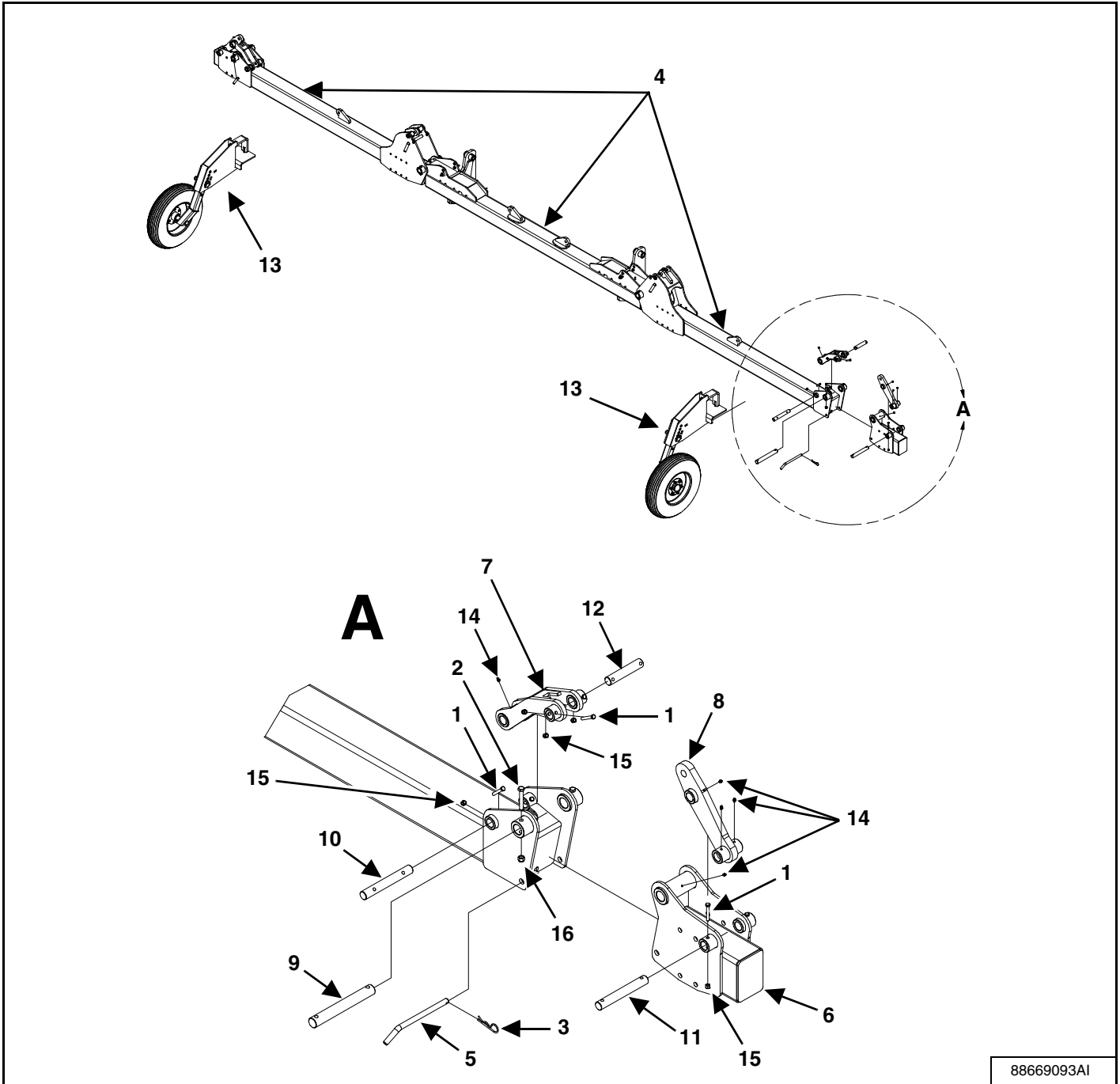

ITEM	PART NUMBER	DESCRIPTION	QTY
1	00087936	CSHHP, 0.38" x 2-1/2" LG	12
2	00088043	BOLT, 1/2" x 3-1/4" HEX GR 5 YZ	4
3	88665916	PIN, HAIR 0.875"	2
4	88669107	ASSEMBLY, TOOLBAR BASE, GREEN	1
	88669106	ASSEMBLY, TOOLBAR BASE, RED	2
5	88669152	PIN, OUTER TOOLBAR MAN	2
6	88669236	WELDMENT, OUTER MAN TB SMALL GREEN	2
	88669235	WELDMENT, OUTER MAN TB SMALL RED	2
7	88669245	WELDMENT, I CYL LINK GREEN	2
	88669244	WELDMENT, I CYL LINK RED	2
8	88669248	WELDMENT, T CYL LINK GREEN	2
	88669247	WELDMENT, T CYL LINK RED	2
9	88669257	PIN, OUTER TOOLBAR MAIN	2
10	88669258	PIN, OUTER TOOLBAR SWING	2
11	88669259	PIN, OUTER TOOLBAR HINGE	2
12	88669262	PIN, OUTER TB LINK SMALL	2
13	88669369	GAUGE WHEEL ASSEMBLY	2
14	SXG1641	GREASE ZERK, 1/4"-28 STRAIGHT	10
15	SXLN-038-NIYZ	LOCKNUT, 3/8" NYLON INSERT YZ	12
16	SXLN-050-NI-YZ	LOCKNUT, 1/2" NYLON INSERT YZ	4

TOOLBAR ASSEMBLY (325 / 400.5 IN.)

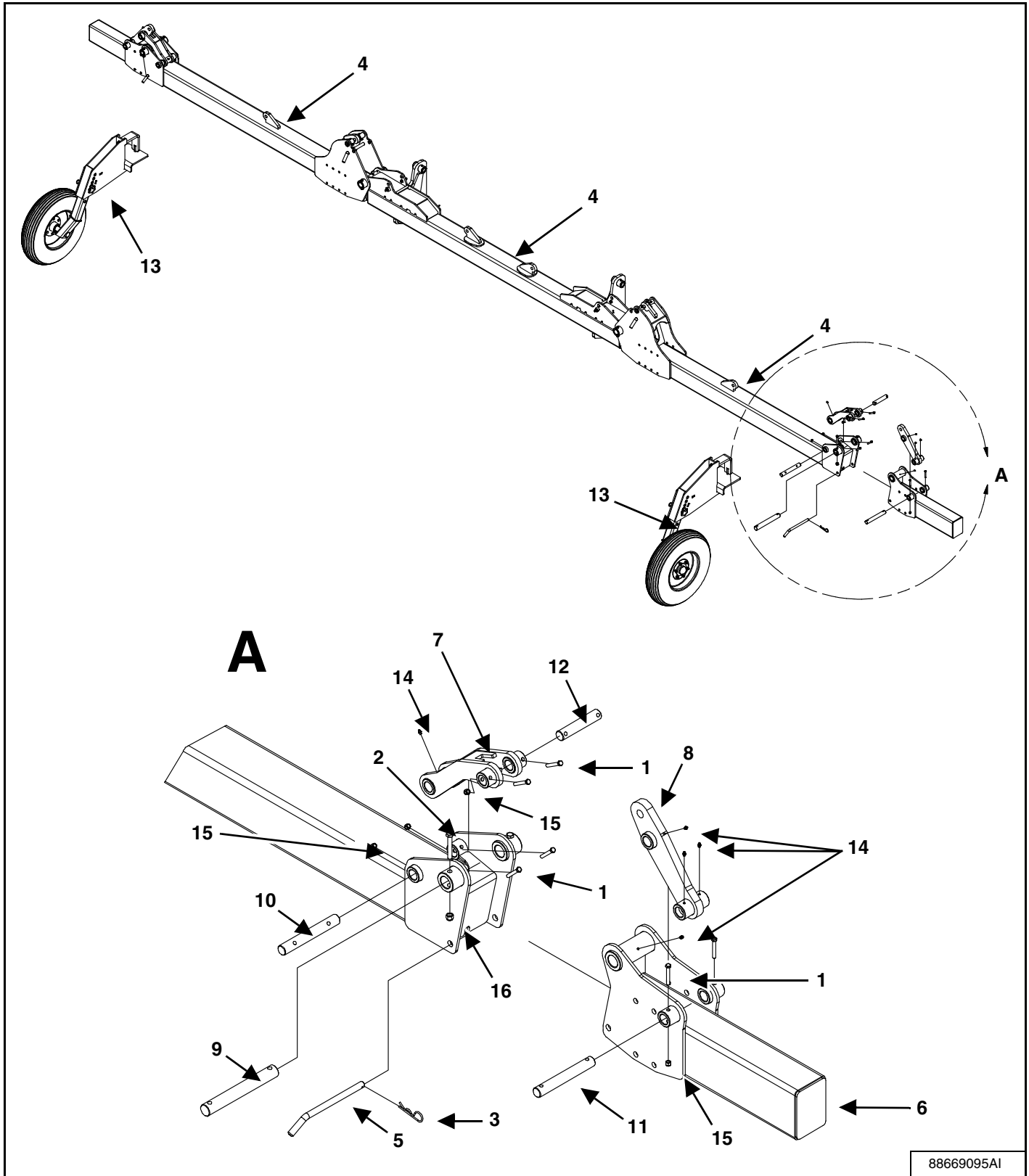

88669095AI

ITEM	PART NUMBER	DESCRIPTION	QTY
1	00087936	CSHHP, 0.38" x 2-1/2" LG	12
2	00088043	BOLT, 1/2" x 3-1/4" HEX GR 5 YZ	4
3	88665916	PIN, HAIR 0.875"	2
4	88669107	ASSEMBLY, TOOLBAR BASE, GREEN	1
	88669106	ASSEMBLY, TOOLBAR BASE, RED	2
5	88669152	PIN, OUTER TOOLBAR MAN	2
6	88669236	WELDMENT, OUTER MAN TB SMALL GREEN	2
	88669235	WELDMENT, OUTER MAN TB SMALL RED	2
7	88669245	WELDMENT, I CYL LINK GREEN	2
	88669244	WELDMENT, I CYL LINK RED	2
8	88669248	WELDMENT, T CYL LINK GREEN	2
	88669247	WELDMENT, T CYL LINK RED	2
9	88669257	PIN, OUTER TOOLBAR MAIN	2
10	88669258	PIN, OUTER TOOLBAR SWING	2
11	88669259	PIN, OUTER TOOLBAR HINGE	2
12	88669262	PIN, OUTER TB LINK SMALL	2
13	88669369	GAUGE WHEEL ASSEMBLY	2
14	SXG1641	GREASE ZERK, 1/4"-28 STRAIGHT	10
15	SXLN-038-NIYZ	LOCKNUT, 3/8" NYLON INSERT YZ	12
16	SXLN-050-NI-YZ	LOCKNUT, 1/2" NYLON INSERT YZ	4

TOOLBAR ASSEMBLY (325 / 489.5 IN.)

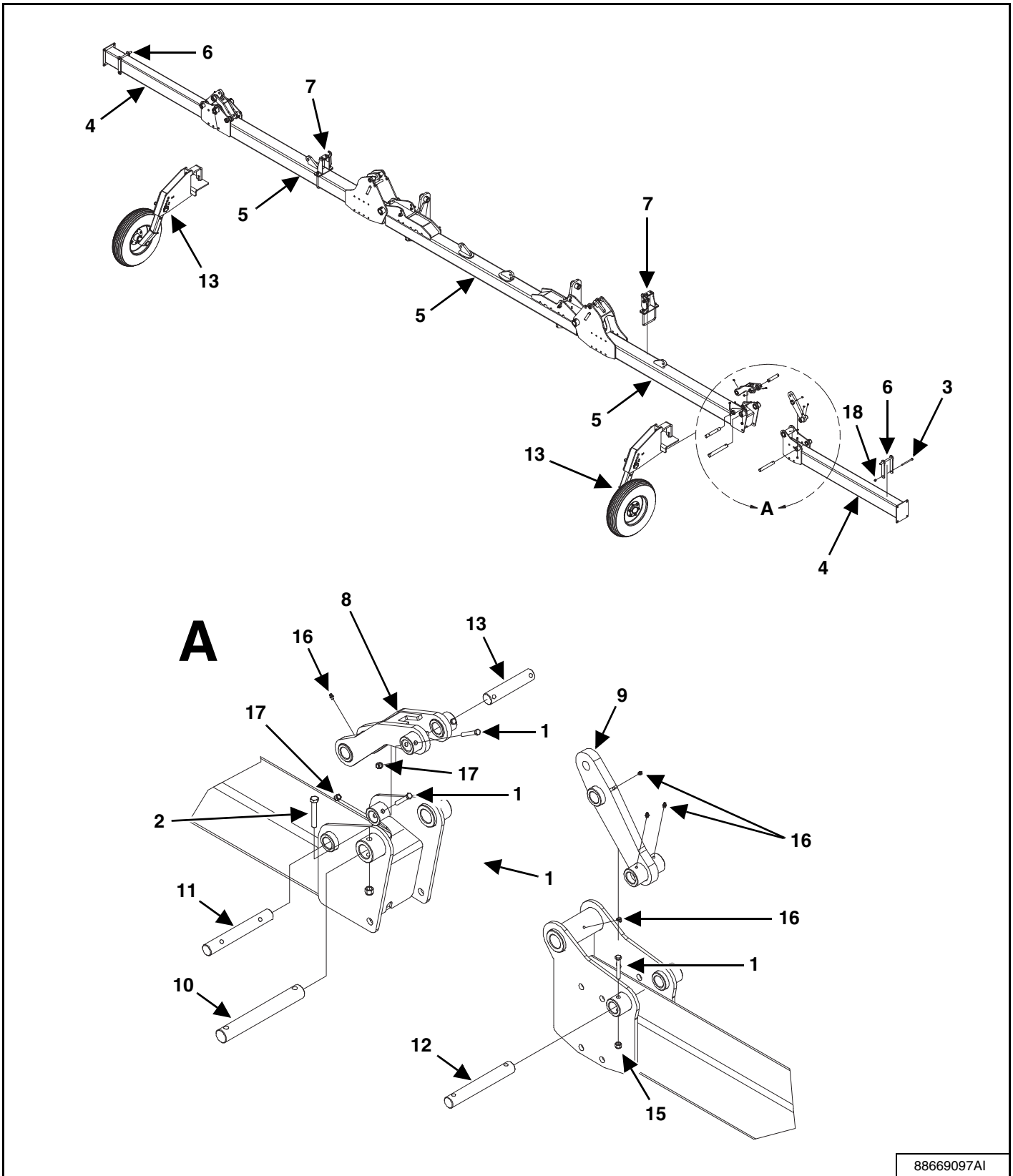

88669097AI

ITEM	PART NUMBER	DESCRIPTION	QTY
1	00087936	CSHHP, 0.38" x 2-1/2" LG	12
2	00088043	BOLT, 1/2" x 3-1/4" HEX GR 5 YZ	4
3	88663900	CSHH G5P 1/2" x 6-1/2"	2
4	88669089	WELDMENT, OUTER TOOLBAR, GREEN	2
	88669088	WELDMENT, OUTER TOOLBAR, RED	2
5	88669107	ASSEMBLY, TOOLBAR BASE, GREEN	2
	88669106	ASSEMBLY, TOOLBAR BASE, RED	2
6	88669227	WELDMENT, TOOLBAR LATCH	2
7	88669233	ASSEMBLY, TOOLBAR GOOSE HOOK	2
8	88669245	WELDMENT, I CYL LINK GREEN	2
	88669244	WELDMENT, I CYL LINK RED	2
9	88669248	WELDMENT, T CYL LINK GREEN	2
	88669247	WELDMENT, T CYL LINK RED	2
10	88669257	PIN, OUTER TOOLBAR MAIN	2
11	88669258	PIN, OUTER TOOLBAR SWING	2
12	88669259	PIN, OUTER TOOLBAR HINGE	2
13	88669262	PIN, OUTER TB LINK SMALL	2
14	88669369	ASSEMBLY, GAUGE WHEEL	2
15	SXG1637	ZERK, 1/4"-28 45 DEG. GREASE	2
16	SXG1641	ZERK, GREASE, 1/4"-28 STRAIGHT	8
17	SXLN-038-NIYZ	LOCKNUT, 3/8" NYLON INSERT YZ	12
18	SXLN-050-NI-YZ	LOCKNUT, 1/2" NYLON INSERT YZ	6

TOOLBAR ASSEMBLY (325 / 533 IN.)

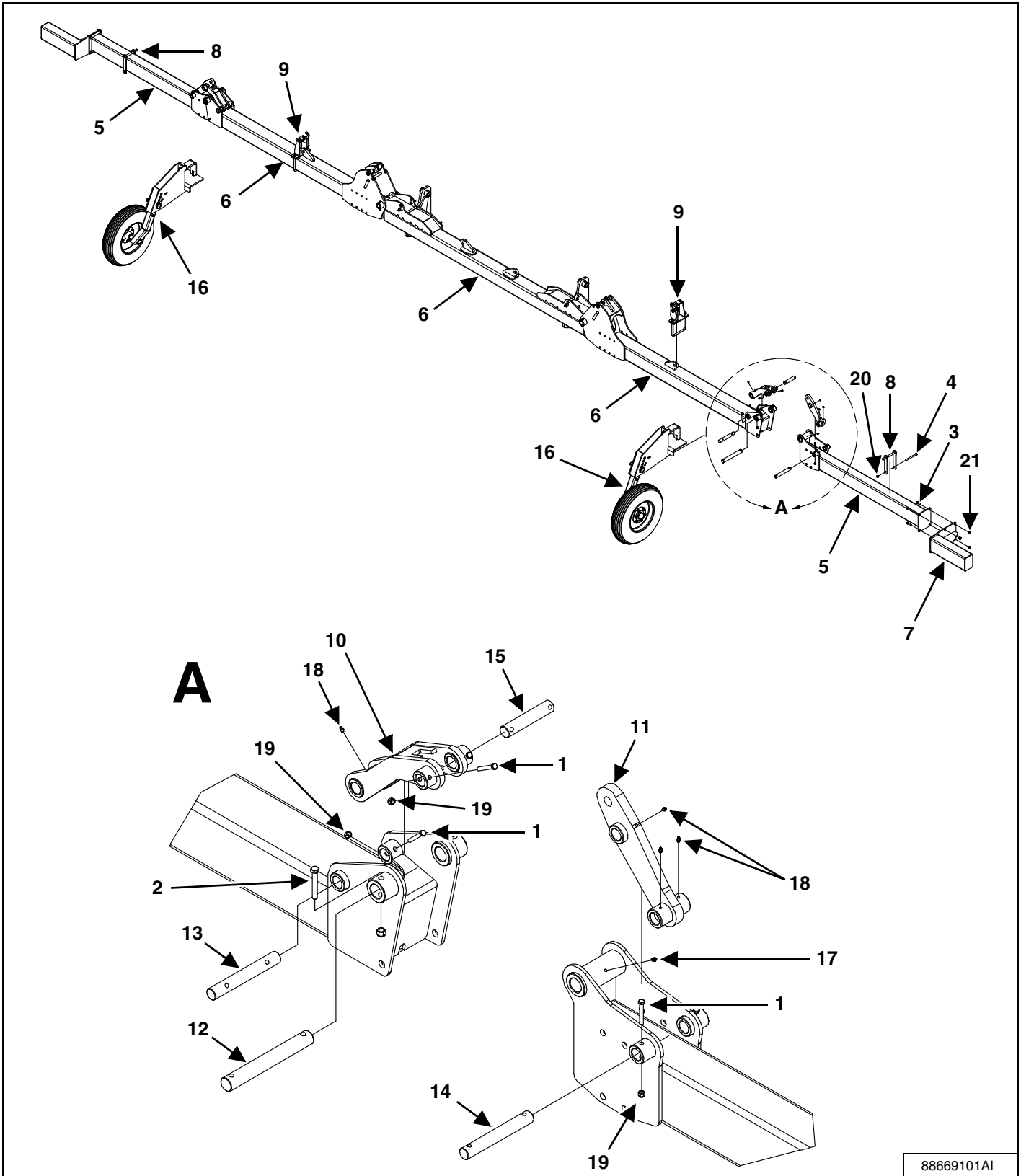

88669101AI

ITEM	PART NUMBER	DESCRIPTION	QTY
1	00087936	CSHHP, 0.38" x 2-1/2" LG	12
2	00088043	BOLT, 1/2" x 3-1/4" HEX GR 5 YZ	4
3	09627896	BOLT, 0.62" x 1-3/4" HEX GR 5 PL	8
4	88663900	CSHH, 0.50" x 6-1/2" G5 P	2
5	88669089	WELDMENT, OUTER TOOLBAR, GREEN	2
	88669088	WELDMENT, OUTER TOOLBAR, RED	2
6	88669107	ASSEMBLY, TOOLBAR BASE, GREEN	2
	88669106	ASSEMBLY, TOOLBAR BASE, RED	2
7	88669147	WELDMENT, TOOLBAR END ADD ON, GRN	2
	88669244	WELDMENT, I CYL LINK RED	2
8	88669227	WELDMENT, TOOLBAR LATCH	2
9	88669233	ASSEMBLY, TOOLBAR GOOSE HOOK	2
10	88669245	WELDMENT, I CYL LINK GREEN	2
	88669244	WELDMENT, I CYL LINK RED	2
11	88669248	WELDMENT, T CYL LINK GREEN	2
	88669247	WELDMENT, T CYL LINK RED	2
12	88669257	PIN, OUTER TOOLBAR MAIN	2
13	88669258	PIN, OUTER TOOLBAR SWING	2
14	88669259	PIN, OUTER TOOLBAR HINGE	2
15	88669262	PIN, OUTER TB LINK SMALL	2
16	88669369	ASSEMBLY, GAUGE WHEEL	2
17	SXG1637	ZERK, 1/4"-28 45 DEG. GREASE	2
18	SXG1641	ZERK, GREASE, 1/4"-28 STRAIGHT	8
19	SXLN-038-NIYZ	LOCKNUT, 3/8" NYLON INSERT YZ	12
20	SXLN-050-NI-YZ	LOCKNUT, 1/2" NYLON INSERT YZ	6
21	SXLN-062-NI-YZ	LOCKNUT, 5/8" NYLON INSERT YZ	8

TOOLBAR ASSEMBLY (357 / 533 IN.)

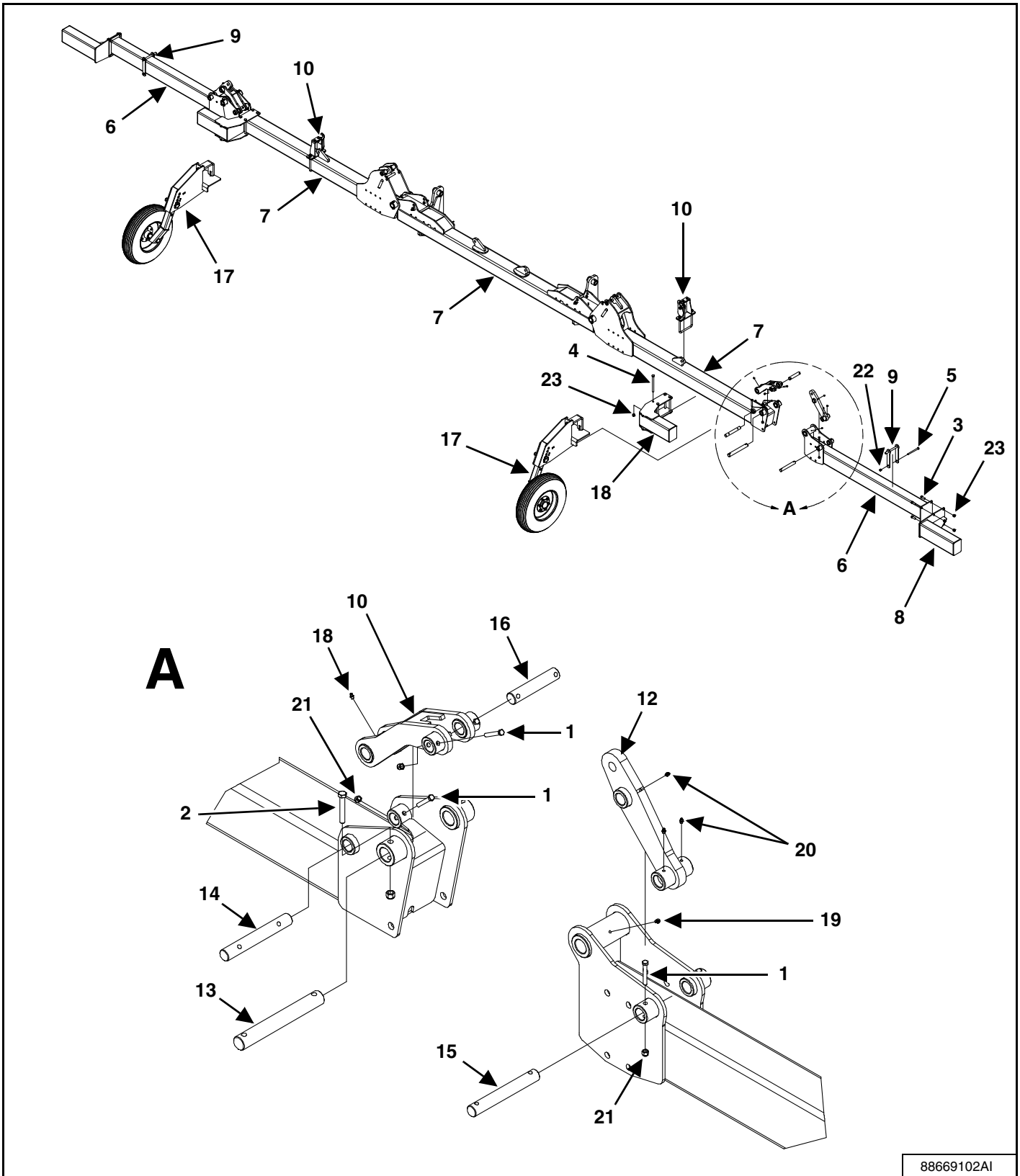

88669102AI

ITEM	PART NUMBER	DESCRIPTION	QTY
1	00087936	CSHHP, 0.38" x 2-1/2" LG	12
2	00088043	BOLT, 1/2" x 3-1/4" HEX GR 5 YZ	4
3	09627896	BOLT, 0.62" x 1-3/4" HEX GR 5 PL	8
4	86507001	BOLT, HEX, 5/8-11 X 8.50 G5 YZ	8
5	88663900	CSHH, 0.50" x 6-1/2" G5 P	2
6	88669089	WELDMENT, OUTER TOOLBAR, GREEN	2
	88669088	WELDMENT, OUTER TOOLBAR, RED	2
7	88669107	ASSEMBLY, TOOLBAR BASE, GREEN	1
	88669106	ASSEMBLY, TOOLBAR BASE, RED	1
8	88669147	WELDMENT, TOOLBAR END ADD ON, GRN	2
	88669244	WELDMENT, I CYL LINK RED	2
9	88669227	WELDMENT, TOOLBAR LATCH	2
10	88669233	ASSEMBLY, TOOLBAR GOOSE HOOK	2
11	88669245	WELDMENT, I CYL LINK GREEN	2
	88669244	WELDMENT, I CYL LINK RED	2
12	88669248	WELDMENT, T CYL LINK GREEN	2
	88669247	WELDMENT, T CYL LINK RED	2
13	88669257	PIN, OUTER TOOLBAR MAIN	2
14	88669258	PIN, OUTER TOOLBAR SWING	2
15	88669259	PIN, OUTER TOOLBAR HINGE	2
16	88669262	PIN, OUTER TB LINK SMALL	2
17	88669369	ASSEMBLY, GAUGE WHEEL	2
18	88669776	WELDMENT, BOLT ON TB SHORT, GREEN	2
	88669775	WELDMENT, BOLT ON TB SHORT, RED	2
19	SXG1637	ZERK, 1/4"-28 45 DEG. GREASE	2
20	SXG1641	ZERK, GREASE, 1/4"-28 STRAIGHT	8
21	SXLN-038-NIYZ	LOCKNUT, 3/8" NYLON INSERT YZ	12
22	SXLN-050-NI-YZ	LOCKNUT, 1/2" NYLON INSERT YZ	6
23	SXLN-062-NI-YZ	LOCKNUT, 5/8" NYLON INSERT YZ	8

TOOLBAR ASSEMBLY (375 / 489.5 IN.)

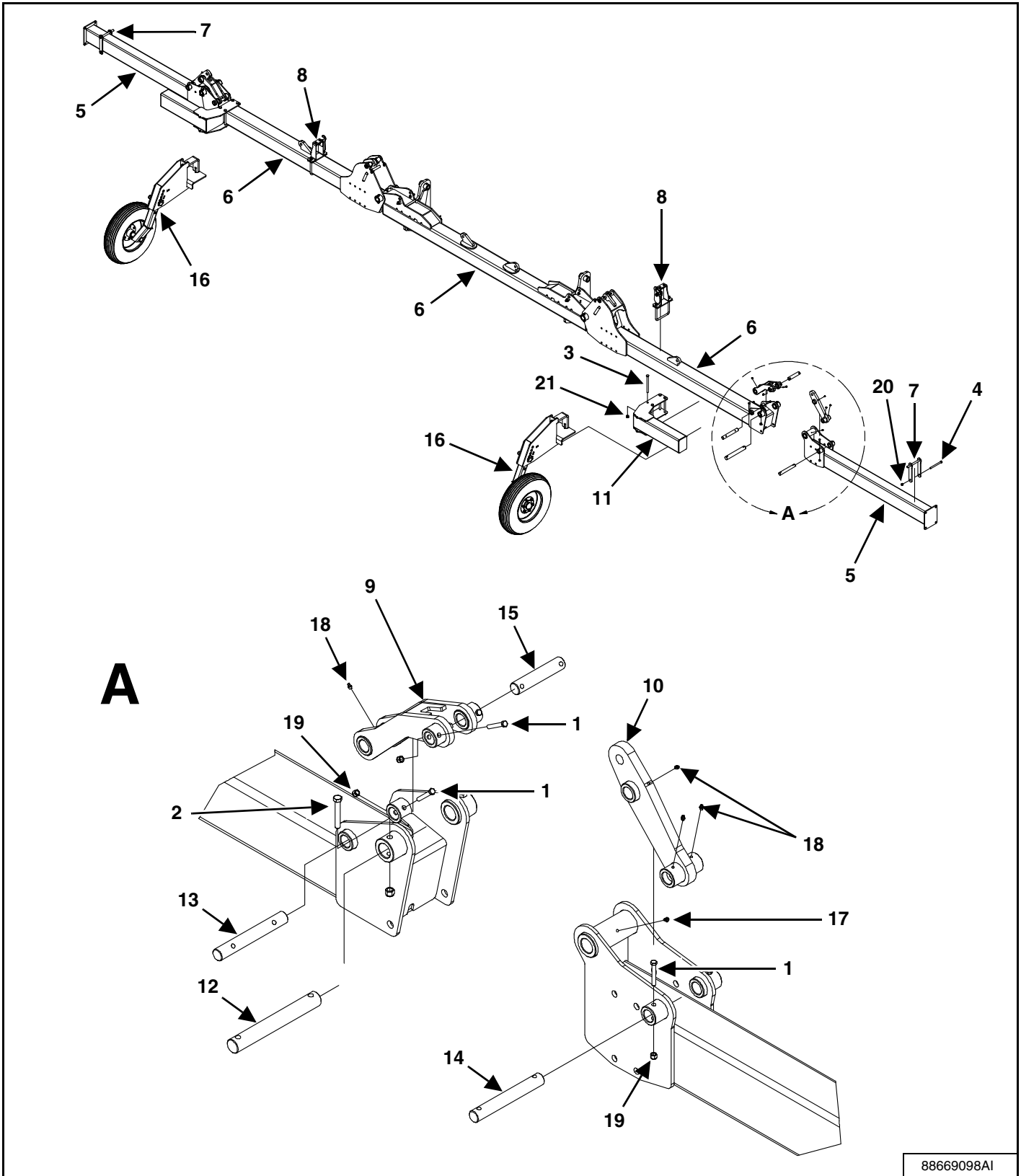

88669098AI

ITEM	PART NUMBER	DESCRIPTION	QTY
1	00087936	CSHHP, 0.38" x 2-1/2" LG	12
2	00088043	BOLT, 1/2" x 3-1/4" HEX GR 5 YZ	4
3	86507001	BOLT, 5/8-11 x 8-1/2" HEX GR 5 YZ	2
4	88663900	CSHHP, 1/2" x 6-1/2" LG	2
5	88669089	WELDMENT, OUTER TOOLBAR GREEN	2
	88669088	WELDMENT, OUTER TOOLBAR RED	2
6	88669107	ASSEMBLY, TOOLBAR BASE, GREEN	1
	88669106	ASSEMBLY, TOOLBAR BASE, RED	1
7	88669152	WELDMENT, TOOLBAR LATCH	2
8	88669233	ASSEMBLY, TOOLBAR GOOSE HOOK	2
9	88669245	WELDMENT, I CYL LINK GREEN	2
	88669244	WELDMENT, I CYL LINK RED	2
10	88669248	WELDMENT, T CYL LINK GREEN	2
	88669247	WELDMENT, T CYL LINK RED	2
11	88669236	WELDMENT, BOLT-ON TOOLBAR GREEN	2
	88669244	WELDMENT, BOLT-ON TOOLBAR RED	2
12	88669257	PIN, OUTER TOOLBAR MAIN	2
13	88669258	PIN, OUTER TOOLBAR SWING	2
14	88669259	PIN, OUTER TOOLBAR HINGE	2
15	88669262	PIN, OUTER TB LINK SMALL	2
16	88669369	GAUGE WHEEL ASSEMBLY	2
17	SXG1641	GREASE ZERK, 1/4"-28 45 DEGREE	8
18	SXG1641	GREASE ZERK, 1/4"-28 STRAIGHT	8
19	SXLN-038-NIYZ	LOCKNUT, 3/8" NYLON INSERT YZ	12
20	SXLN-050-NI-YZ	LOCKNUT, 1/2" NYLON INSERT YZ	4
21	SXLN-062-NI-YZ	LOCKNUT, 5/8" NYLON INSERT YZ	8

ITEM	PART NUMBER	DESCRIPTION	QTY
1	00087936	CSHHP, 0.38" x 2-1/2" LG	12
2	00088043	BOLT, 1/2" x 3-1/4" HEX GR 5 YZ	4
3	09627896	BOLT, 0.62" x 1-3/4" HEX GR 5 PL	8
4	86507001	BOLT, HEX, 5/8-11 x 8.50 G5 YZ	8
5	88663900	CSHH, 0.50" x 6-1/2" G5 P	2
6	88669089	WELDMENT, OUTER TOOLBAR, GREEN	2
	88669088	WELDMENT, OUTER TOOLBAR, RED	2
7	88669107	ASSEMBLY, TOOLBAR BASE, GREEN	1
	88669106	ASSEMBLY, TOOLBAR BASE, RED	1
8	88669147	WELDMENT, TOOLBAR END ADD ON, GRN	2
	88669244	WELDMENT, I CYL LINK RED	2
9	88669227	WELDMENT, TOOLBAR LATCH	2
10	88669233	ASSEMBLY, TOOLBAR GOOSE HOOK	2
11	88669245	WELDMENT, I CYL LINK GREEN	2
	88669244	WELDMENT, I CYL LINK RED	2
12	88669248	WELDMENT, T CYL LINK GREEN	2
	88669247	WELDMENT, T CYL LINK RED	2
13	88669248	WELDMENT, T CYL LINK GREEN	2
	88669247	WELDMENT, T CYL LINK RED	2
14	88669257	PIN, OUTER TOOLBAR MAIN	2
15	88669258	PIN, OUTER TOOLBAR SWING	2
16	88669259	PIN, OUTER TOOLBAR HINGE	2
17	88669262	PIN, OUTER TB LINK SMALL	2
18	88669369	ASSEMBLY, GAUGE WHEEL	2
19	SXG1637	ZERK, 1/4"-28 45 DEG. GREASE	2
20	SXG1641	ZERK, GREASE, 1/4"-28 STRAIGHT	8
21	SXLN-038-NIYZ	LOCKNUT, 3/8" NYLON INSERT YZ	12
22	SXLN-050-NI-YZ	LOCKNUT, 1/2" NYLON INSERT YZ	6
23	SXLN-062-NI-YZ	LOCKNUT, 5/8" NYLON INSERT YZ	16

TOOLBAR BASE ASSEMBLY

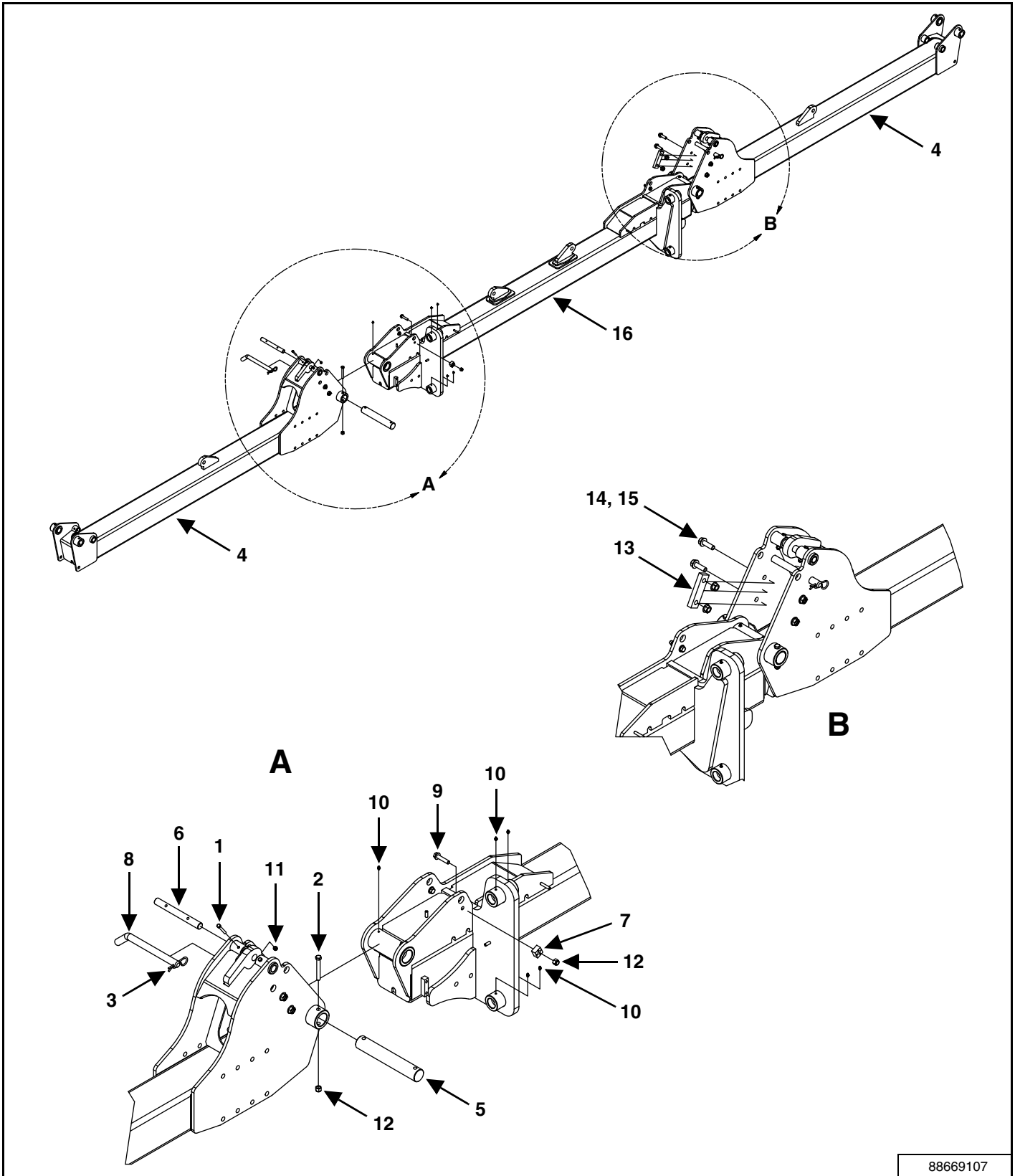

88669107

ITEM	PART NUMBER	DESCRIPTION	QTY
1	86505972	CSHH G5P 0.31" x 2-1/4" 86505344	4
2	86505992	CSHH G5P 1/2" x 3-3/4" 86505344	4
3	88665917	HAIR PIN, 1"	2
4	88669086	INNER TOOLBAR WELDMENT, GREEN	2
	88669085	INNER TOOLBAR WELDMENT, RED	2
5	88669256	INNER TOOLBAR MAIN PIN	2
6	88669261	INNER TOOLBAR CYLINDER PIN	2
7	88669449	WING STOP PLATE	4
8	88669450	WING LOCK PIN	2
9	SXBHF0502258YZ	BOLT, 1/2" x 2-1/4" FLG GR 8 YLLW ZN	4
10	SXG1641	GREASE ZERK, 1/4"-28 STRAIGHT	12
11	SXLN-031-NIYZ	LOCKNUT, 5/16" NYLON INSERT YZ	4
12	SXLN-050-NI-YZ	LOCKNUT, 1/2" NYLON INSERT YZ	8
13	88670918	WING STOP PLATE	4
14	SXBHF0622008YZ	BOLT, 5/8"x 2" FLG GR 8 YZ	8
15	SXNTFTL062118Y	NUT, 5/8"-11 FLG, GR 8	8
16	88670900	CENTER TOOLBAR, GREEN	1
	88670899	CENTER TOOLBAR, RED	1

TOOLBAR ASSEMBLY (325 IN.)

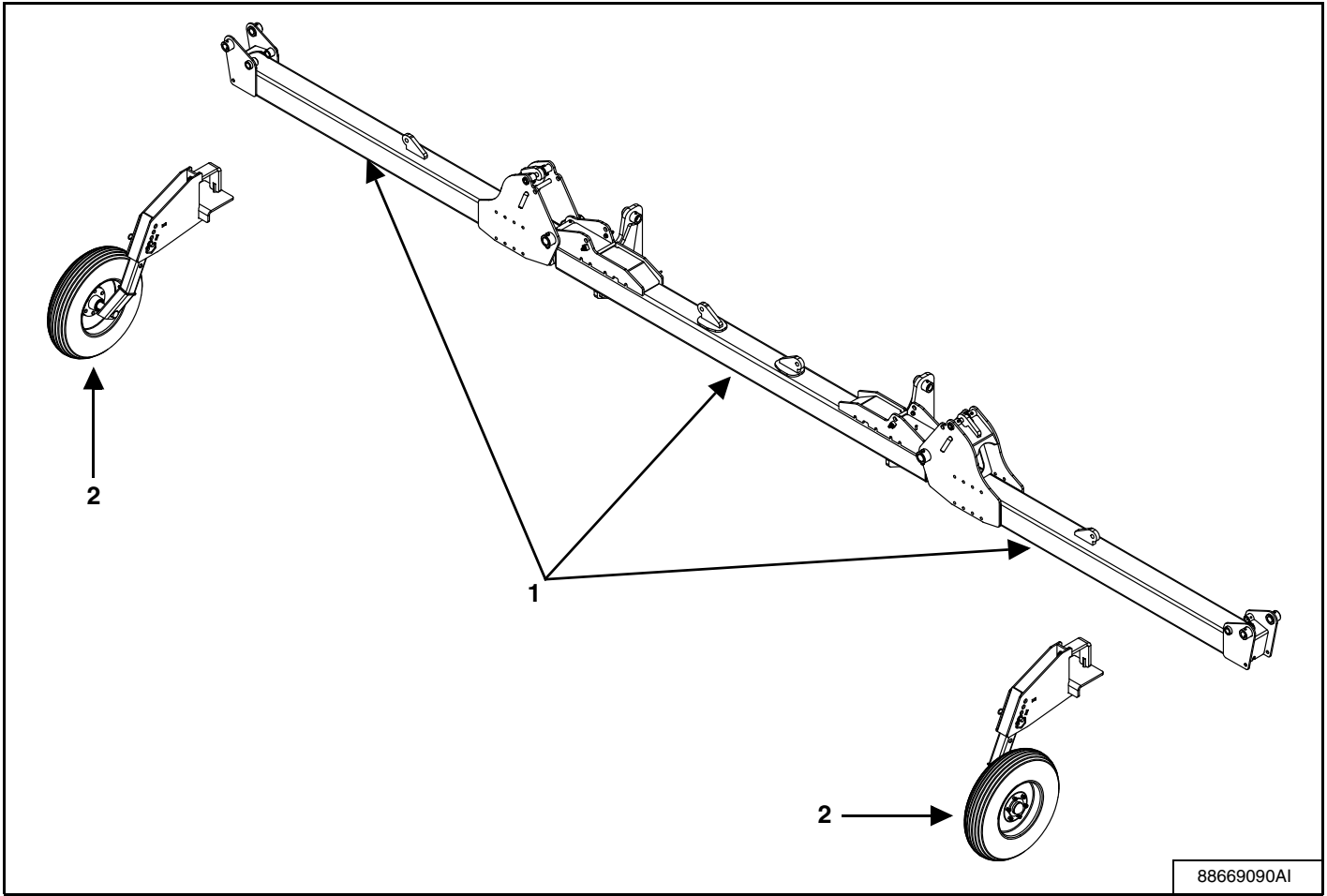

ITEM	PART NUMBER	DESCRIPTION	QTY
1	88669107	ASSEMBLY, TOOLBAR BASE, GREEN	1
	88669106	ASSEMBLY, TOOLBAR BASE, RED	1
2	88669369	ASSEMBLY, GAUGE WHEEL	2

GAUGE WHEEL

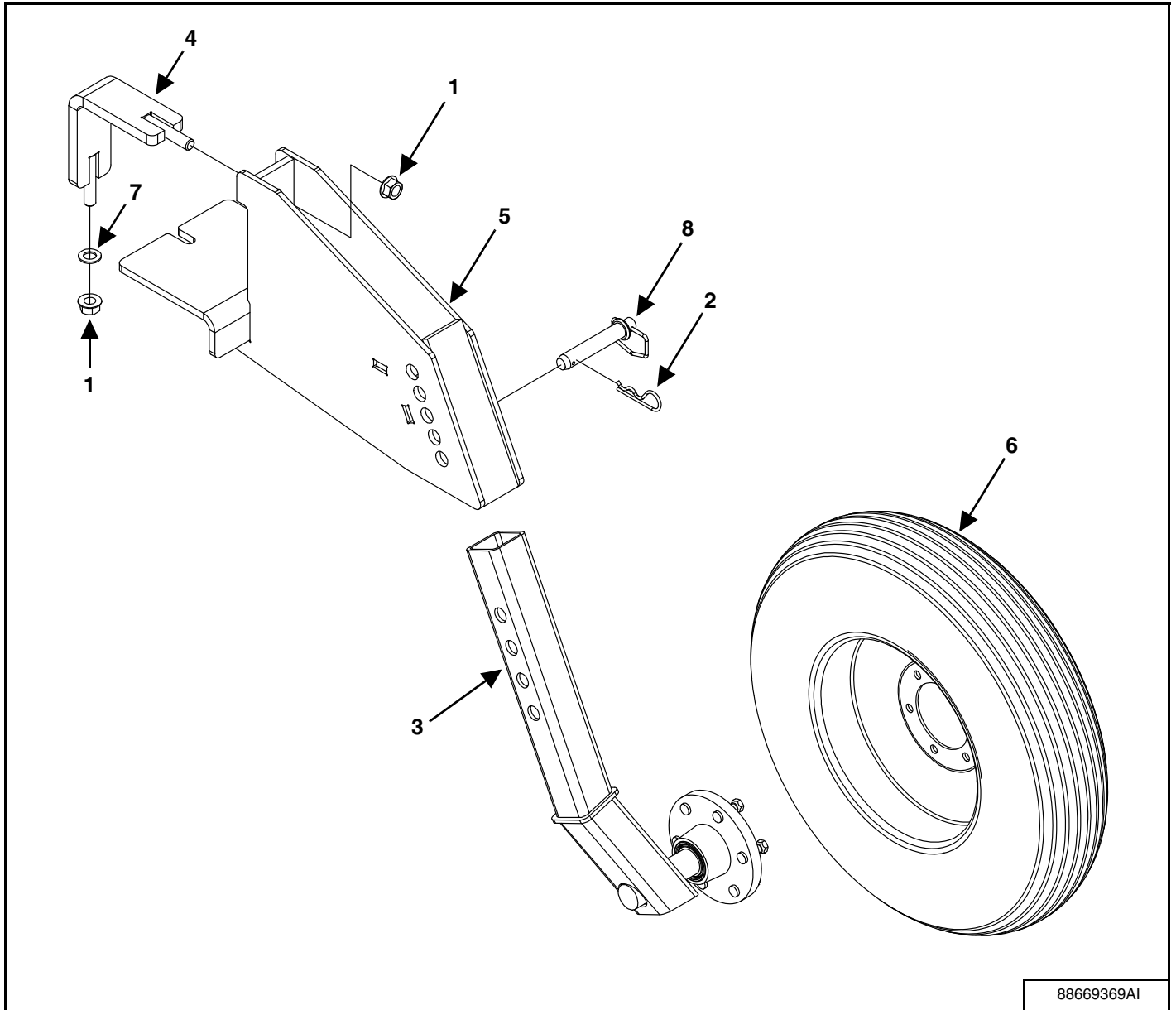

ITEM	PART NUMBER	DESCRIPTION	QTY
1	SXPHI-100-525	HITCH PIN, SXPHI-100-525 1" x 5-1/4"	2
2	SXFW-075-SAE-YZ	FLATWASHER, 3/4" SAE YLLW ZN	1
3	SX011506B	TIRE & WHEEL ASSEMBLY, 7.6-15SL	1
4	88669364	GAUGE WHEEL WELDMENT	1
5	88669362	STUD TUBE CLAMP WELDMENT	1
6	88669331	GAUGE WHEEL TUBE ASSEMBLY	1
7	88668005	PIN CLIP, 0.177" x 3-3/4" ZINC	1
8	88663952	TOP LOCK NUT, 3/4-10 FLG, GR 5 YZ	1

GAUGE WHEEL HUB

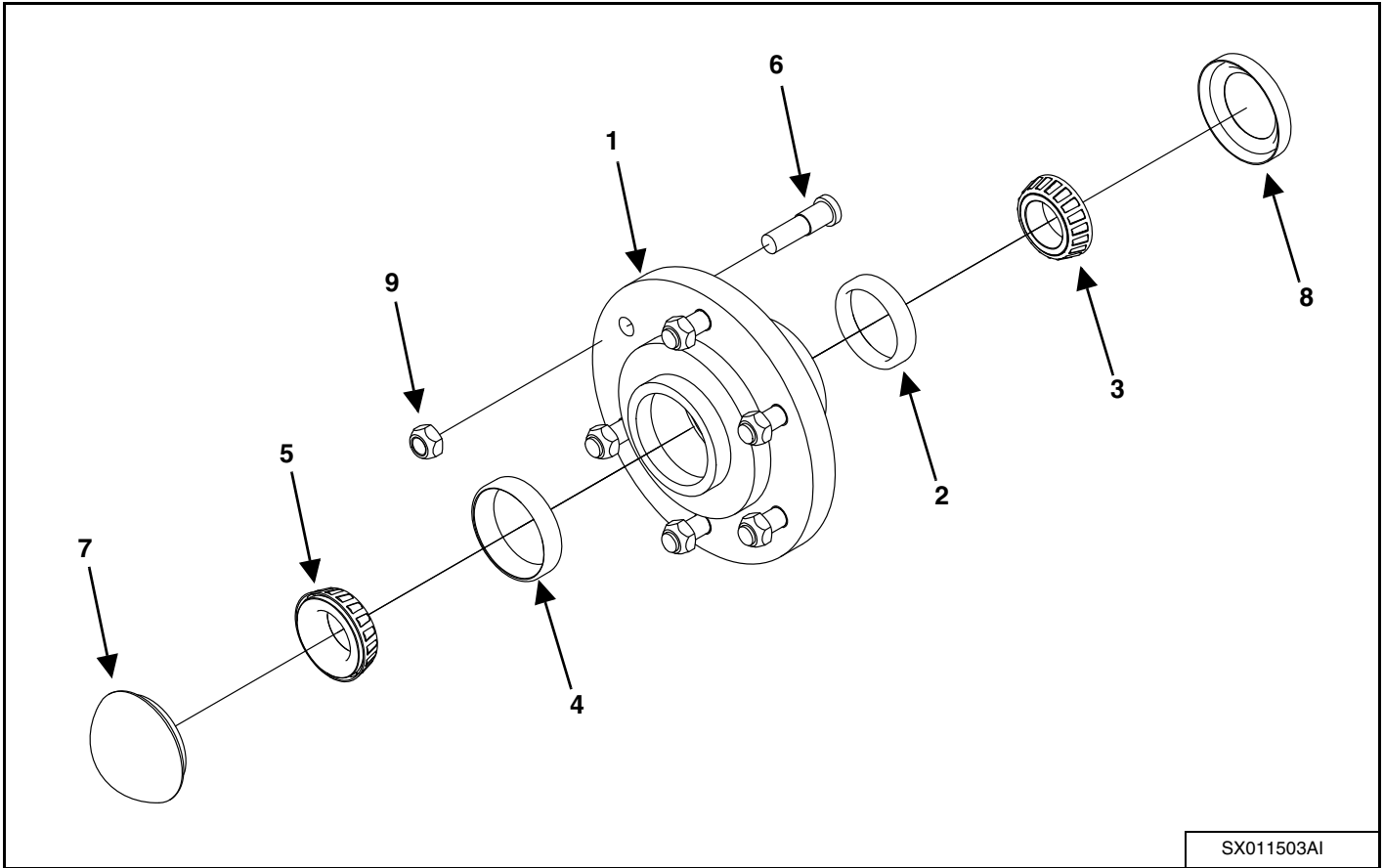

SX011503AI

ITEM	PART NUMBER	DESCRIPTION	QTY
1	88665707	HUB W/CUPS	1
2	88665708	OUTER CUP	1
3	88665709	OUTER CONE	1
4	88665710	INNER CUP	1
5	88665711	INNER CONE	1
6	88665712	STUD	6
7	88665713	CAP, HUB	1
8	88665714	GREASE SEAL	1
9	88665715	NUT	6

TOOLBAR GOOSE HOOK ASSEMBLY

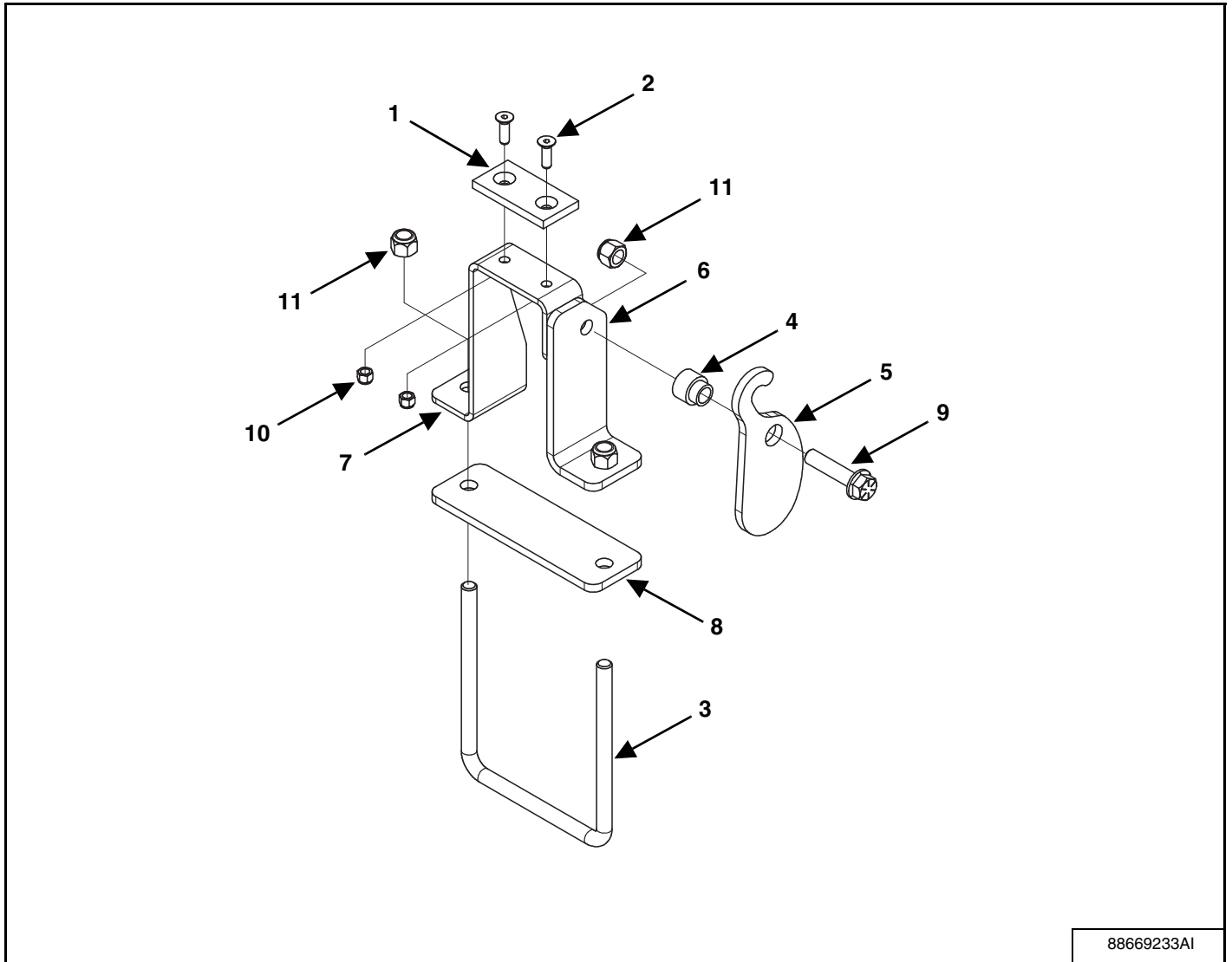

88669233AI

ITEM	PART NUMBER	DESCRIPTION	QTY
1	88660718	TRANSPORT LOCK NYLON WEAR PLATE	1
2	88660723	CAP SCREW, 3/8-16 x 1-1/4" FH SKTCP	2
3	88669054	U-BOLT, 5/8" x 7" x 8-1/2" GR 5 SQ YZ	1
4	88669228	HINGE SPACER BUSHING	1
5	88669229	PREG. GOOSE HOOK PLATE	1
6	88669230	HOOK SIDE MOUNT PLATE	1
7	88669231	SIDE S HOOK PLATE	1
8	88669232	HOOK BASE PLATE	1
9	SXBHF0622758YZ	BOLT, 5/8" x 2-3/4" FLG, GR 8 YZ	1
10	SXLN-038-NIYZ	LOCKNUT, 3/8" NYLON INSERT YZ	2
11	SXLN-062-NI-YZ	LOCKNUT, 5/8" NYLON INSERT YZ	3

ACE PUMP & PLUMBING ASSEMBLY

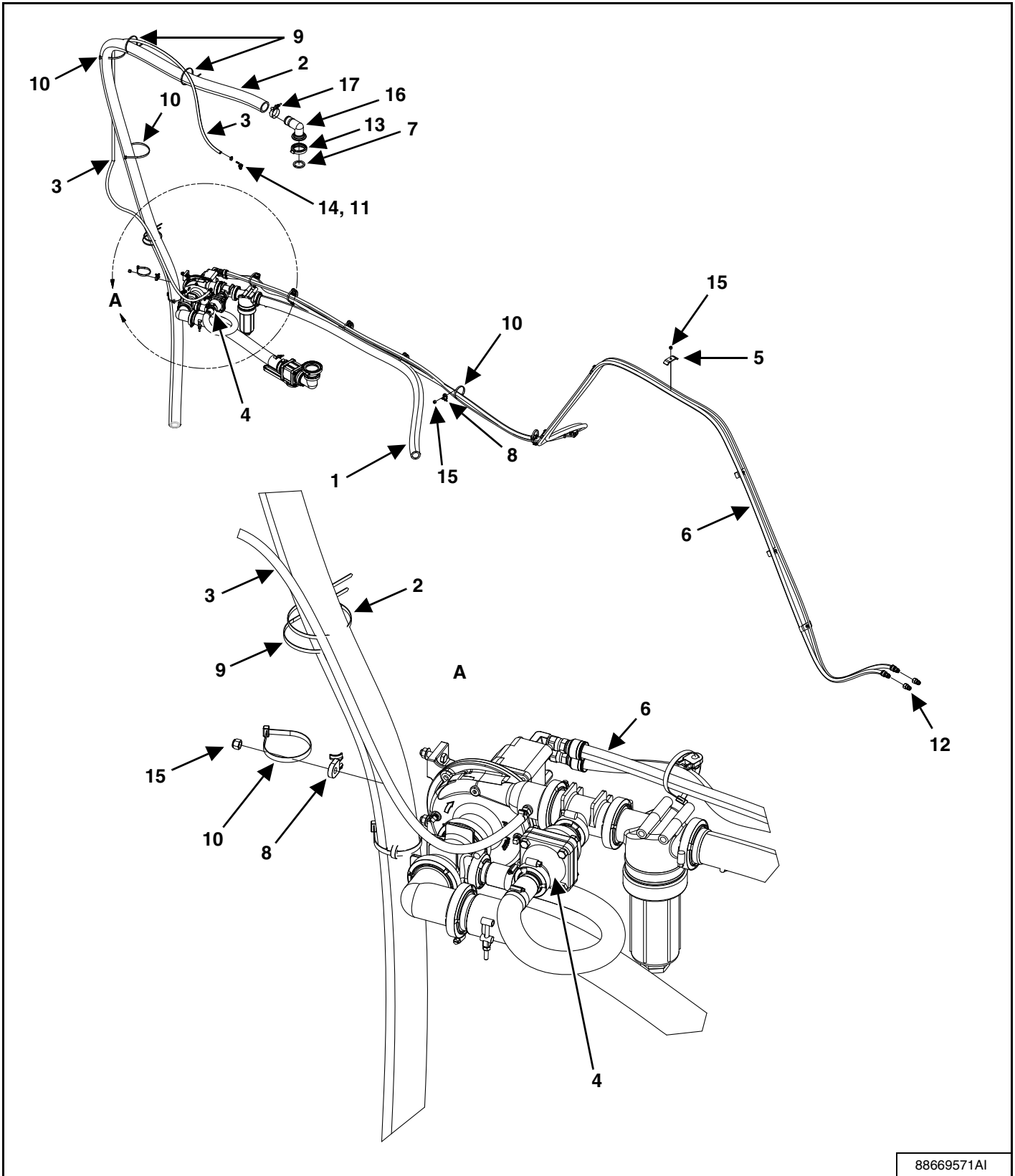

88669571AI

ITEM	PART NUMBER	DESCRIPTION	QTY
1	88664847	HOSE, PRODUCT, 1-1/2"	1
2	88667074	HOSE, PRODUCT, SC, 2"	1
3	88667276	HOSE, 1/4" VINYL RF CLR, 12 FT	1
4	88669597	ACE PUMP SUB-ASSEMBLY	1
5	88669896	BAR, HOSE HOLDER SHORT	6
6	88669953	HOSE ASSY, -8 HYD 350.0" LG	2
7	SX200G	GASKET 2" COUPLING EPDM	1
8	SX21294	MOUNT, CABLE TIE HEAVY DUTY	9
9	SX3NS12	STRAP, 11-1/4" BLACKM 21"	4
10	SX3NS21	STRAP, BLACK 21-1/2"	11
11	SX4JM	CLAMP; 1/4" x 5/16" STAINLESS	1
12	SX8010-15P	HYDRAULIC QUICK COUPLER, UNIV. POPPET	2
13	SXFC220	WORM SCREW CLAMP, 2" SERIES	1
14	SXHB-025-90	HOSE BARB ELL, 1-4 MPT x 1/4 HB	1
15	SXLN-038-NIYZ	LOCKNUT, 3/8" NYLON INSERT YZ	15
16	SXM220BRB90	MANIFOLD, 2" FLG x 2" HB	1
17	SXTBC256	T-BOLT CLAMP, 2-11/32" - 25/8	1

ITEM	PART NUMBER	DESCRIPTION	QTY
1	88661393	1" PRESSURE SPIKE VALVE, 100 PSI	1
2	88663901	CSHH G5P 0.38" x 1-1/2"	2
3	88664864	1" PRODUCT HOSE	1
4	88665312	90 DEG ELBOW, 1/8" STREET M&F	1
5	88669596	PLUMBING TEE, 2" FP x 1"	1
6	88669998	2" PRODUCT HOSE, SC	1
7	SX150G	GASKET, FOR 2" FLANGED VALVE	3
8	SX200G	GASKET, 2" COUPLING EPDM	6
9	SX20J	CLAMP, 1-1/4" x 1/2" STAINLESS	2
10	SX2404-8-8	HYD FITTING, 8 MNPT x 8 JIC STEEL	1
11	SX2501-8-8	HYD ADAPTER, 8 MJIC x 8 MNPT	1
12	SX28J	CLAMP, 1-3/4" x 1/2" STAINLESS	1
13	SX300G	GASKET, 3" BANJO	1
14	SX3A1814	HOSE BARB, 1/8" x 1/4" POLY	1
15	SX4JM	CLAMP, 1/4" x 5/16" STAINLESS	1
16	SX6500-8	HYD FITTING, 8 FJIC x 8 MJIC	1
17	SXFC100BJ	1" CLAMP	3
18	SXFC200BJ	CLAMP, 2" BANJO	3
19	SXFC220	CLAMP; 2" SERIES WORM SCREW	6
20	SXFC300BJ	CLAMP, 3" BANJO	1
21	SXFMCS150HYD	PUMP, CAST, SC SEAL, 1-1/2" ACE	1
22	SXLST1550	SCREEN, 50 MESH, 1-1/4" & 1-1/2" T	1
23	SXM100BRB	HOSE BARB, 1" x 1" STRAIGHT	2
24	SXM100G	GASKET, FOR 1" FLANGED VALVE	3
25	SXM200100TEE	TEE, 2" x 1" TEE	1
26	SXM200150BRB	HOSE BARB, 2" FLG x 1-1/2" HB	1
27	SXM220BRB	HOSE BARB, 2" W/FULL PORT FLG	2
28	SXM220CPG90	FITTING; 2" FULLPORT 90 DEG. COUPLING	2
29	SXM300220CPG	FLANGE, 3" x 2" FULL PORT RED. FL	1
30	SXMLST150-HB	STRAINER, 2" T-HEAD & BODY FLGED	1
31	SXMV220CF	VALVE, 2" FP FLG BANJO	1
32	SXNTFTL038168YZ	NUT FLG, 3/8"-16 UNC TP LCK GR 8 YZ	2
33	SXTBC256	T-BOLT CLAMP, 2-11/32" - 25/8	2

PRODUCT PUMP ASSEMBLY

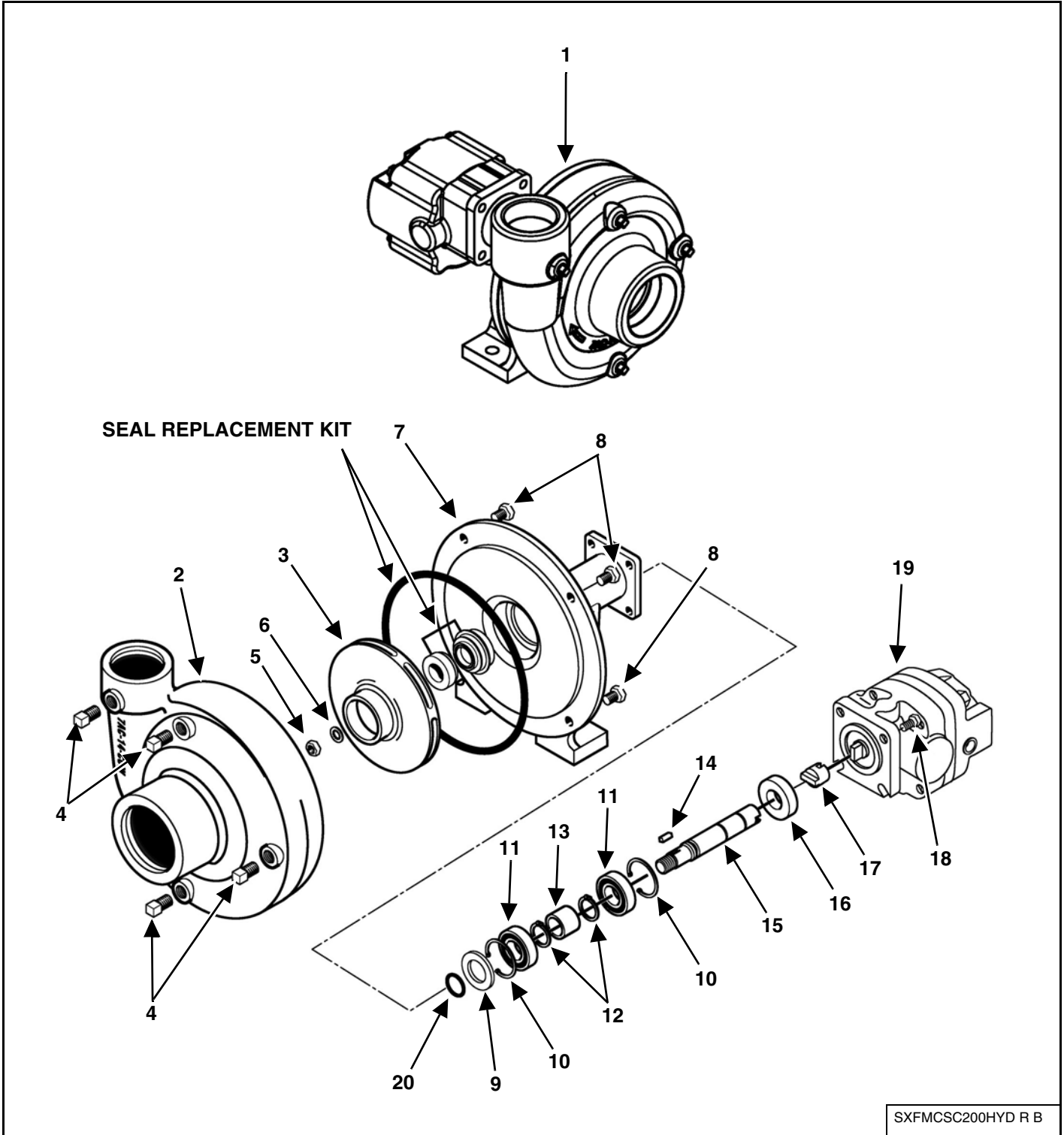

ITEM	PART NUMBER	DESCRIPTION	QTY
1	88663854	PRODUCT PUMP, ASSEMBLY	1
	88661313	SEAL REPLACEMENT KIT	1
	88661316	HYDRAULIC SEAL REPAIR KIT	1
2	88661314	VOLUTE, CAST IRON, 2"	1
3	88661315	VALOX IMPELLER 2"	1
THE FOLLOWING PARTS ARE FOR IDENTIFICATION PURPOSES ONLY			
4		PIPE PLUG	4
		PIPE PLUG, SS (OPTIONAL)	
5		NUT, 3/8" NF	1
6		WASHER, 3/8" STAR, SS	1
7		MOUNTING FRAME	1
8		SCREW, 3/8" NC x 3/4"	4
		SCREW, 3/8" NC x 3/4" SS (OPTIONAL)	
9		SLINGER	1
10		SNAP RING, INTERNAL	2
11		BALL BEARING	2
12		SNAP RING, EXTERNAL	2
13		SPACER	1
14		KEY, 1/8" x 1/8" x 13/16"	1
15		SHAFT, EXTENDED KEYWAY, TANG, SS	1
		SHAFT, 5/8" DIAMETER, KEYWAY, TANG SLOT, SS (OPTIONAL)	
16		SEAL	1
17		COUPLING	1
18		MOTOR TO PUMP SCREW, 5/16" UNC x 3/4"	4
19		HYDRAULIC MOTOR	1
20		O-RING, SHAFT SEAL	1

JB TWIN PUMP PLUMBING ASSEMBLY (1 OF 3)

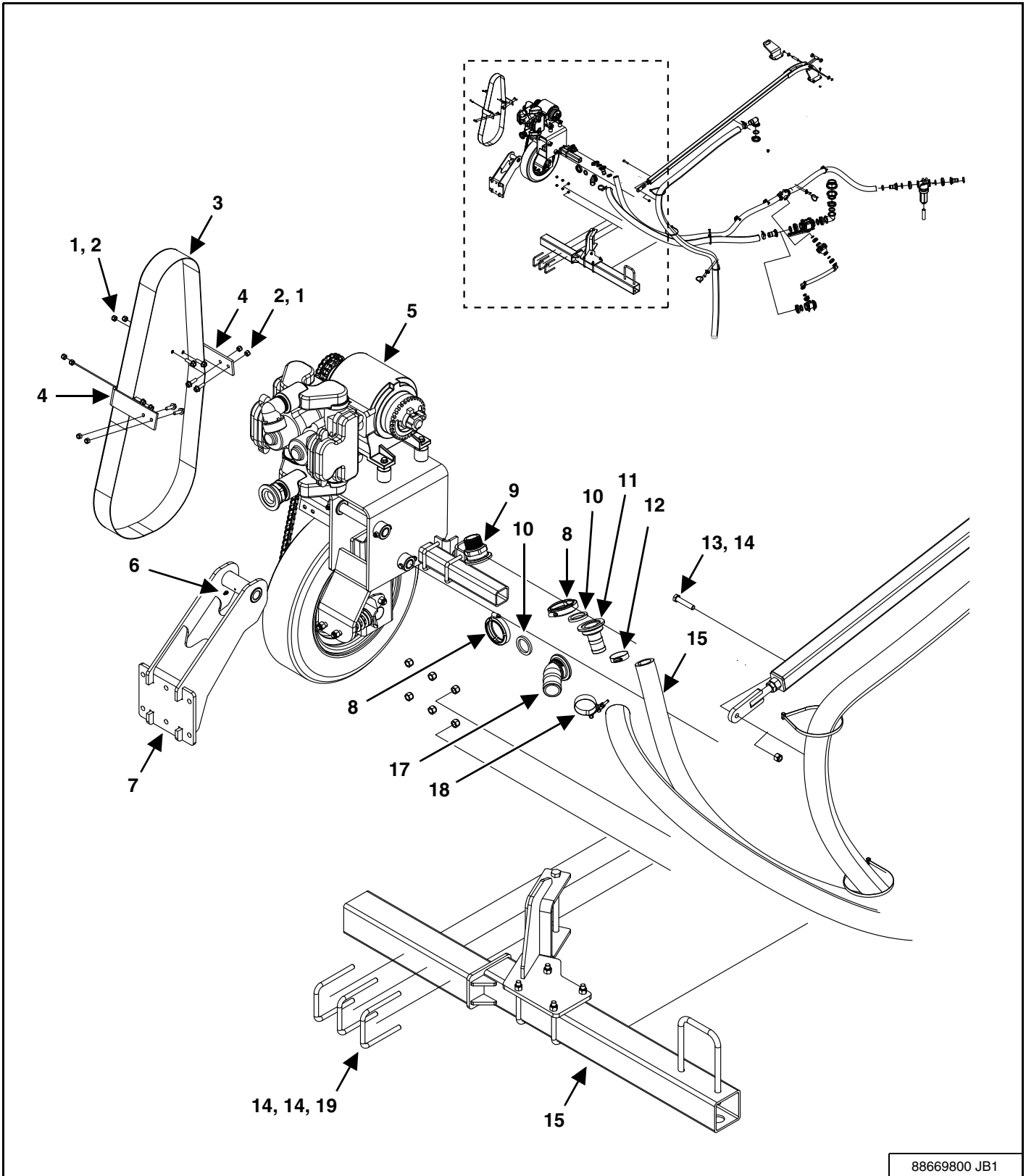

88669800 JB1

ITEM	PART NUMBER	DESCRIPTION	QTY
1	SXBHF0311008YZ	BOLT, 5/16" x 1" FLG GR 8 YLLW ZN	8
2	SXLN-031-NIYZ	LOCKNUT, 5/16" NYLON INSERT YZ	8
3	88670183	JB CHAIN GUARD WELDMENT	1
4	88670190	PLT, FRMD, BRKT	2
5	88669802	JOHN BLUE SUB-ASSEMBLY	1
6	SXG1641	GREASE ZERK, 1/4-28 STRAIGHT	1
7	88669814	REAR TUBE MOUNT WELDMENT	1
8	SXFC200BJ	CLAMP, 2" BANJO	4
9	SXM200150MPT	MANIFOLD, 2" FLG, 1-1/2" MPT	1
10	SX150G	GASKET; FOR 2" FLANGED VALVE	6
11	SXM200150BRB	HOSE BARB, 2" FLG x 1-1/2" HB	5
12	SX28J	STAINLESS CLAMP, 1-3/4" x 1/2"	5
13	00087972	CSHH G5 P 0.50 x 2-1/2" 86505344	1
14	SXLN-050-NI-YZ	LOCKNUT, 1/2" NYLON INSERT YZ	7
15	88667074	PRODUCT HOSE, 2" SC	1
16	88670782	PRODUCT HOSE, 1-1/2"	1
17	88664739	ELBOW FLANGE 2" x 2" HB 45D	1
18	SXTBC256	T-BOLT CLAMP, 2-11/32 - 25/8	3
19	88660697	U-BOLT, 1/2" x 4" x 5-1/2"	3

JB TWIN PUMP PLUMBING ASSEMBLY (2 OF 3)

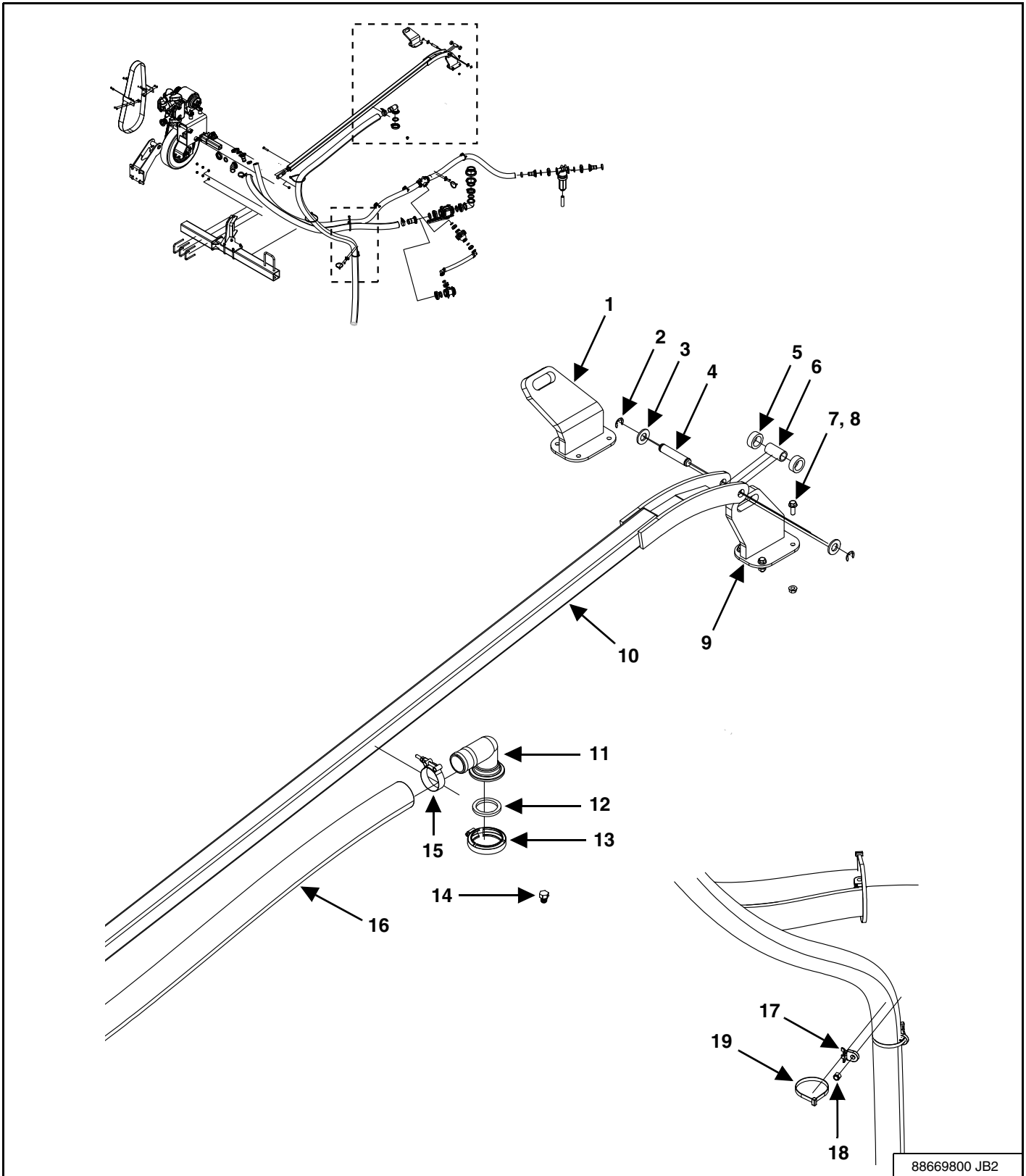

ITEM	PART NUMBER	DESCRIPTION	QTY
1	88670700	OFFSET PARALLEL BRACKET WELDMENT	1
2	88662384	SNAP RING, 3/4" SHAFT	4
3	88667961	BUSHING, MACH 3/4" x 1-1/2" 10 GA	2
4	88670908	RD, PIN 3/4" W/GROOVES	1
5	88670703	SPACER, LUG	2
6	88670702	BUSHING, JB LUG	1
7	SXBHF0381008YZ	BOLT, 3/8" x 1" GR 8 YLLWZN	4
8	SXNTFTL038168YZ	TOP LOCK NUT, 3/8-16 UNC FLG GR 8 YZ	4
9	88669878	JB PARALLEL BRACKET	1
10	88669871	ADJUSTABLE ACTUATOR ASSEMBLY	1
11	SXM220BRB90	MANIFOLD; 2" FLG x 2" HB	1
12	SX200G	COUPLING GASKET, 2" EPDM	5
13	SXFC220	WORM SCREW CLAMP, 2" SERIES	5
14	SX3F14	PLUG, 1/4" POLY, HEX	1
15	SXTBC256	T-BOLT CLAMP, 2-11/32-25/8	3
16	88667074	PRODUCT HOSE, 2" SC	1
17	SX21294	HEAVY DUTY CABLE TIE MOUNT	7
18	SXLN-038-NIYZ	LOCKNUT, 3/8" NYLON INSERT YZ	7
19	SX3NS21	STRAP, BLACK 21-1/2"	9

JB TWIN PUMP PLUMBING ASSEMBLY (3 OF 3)

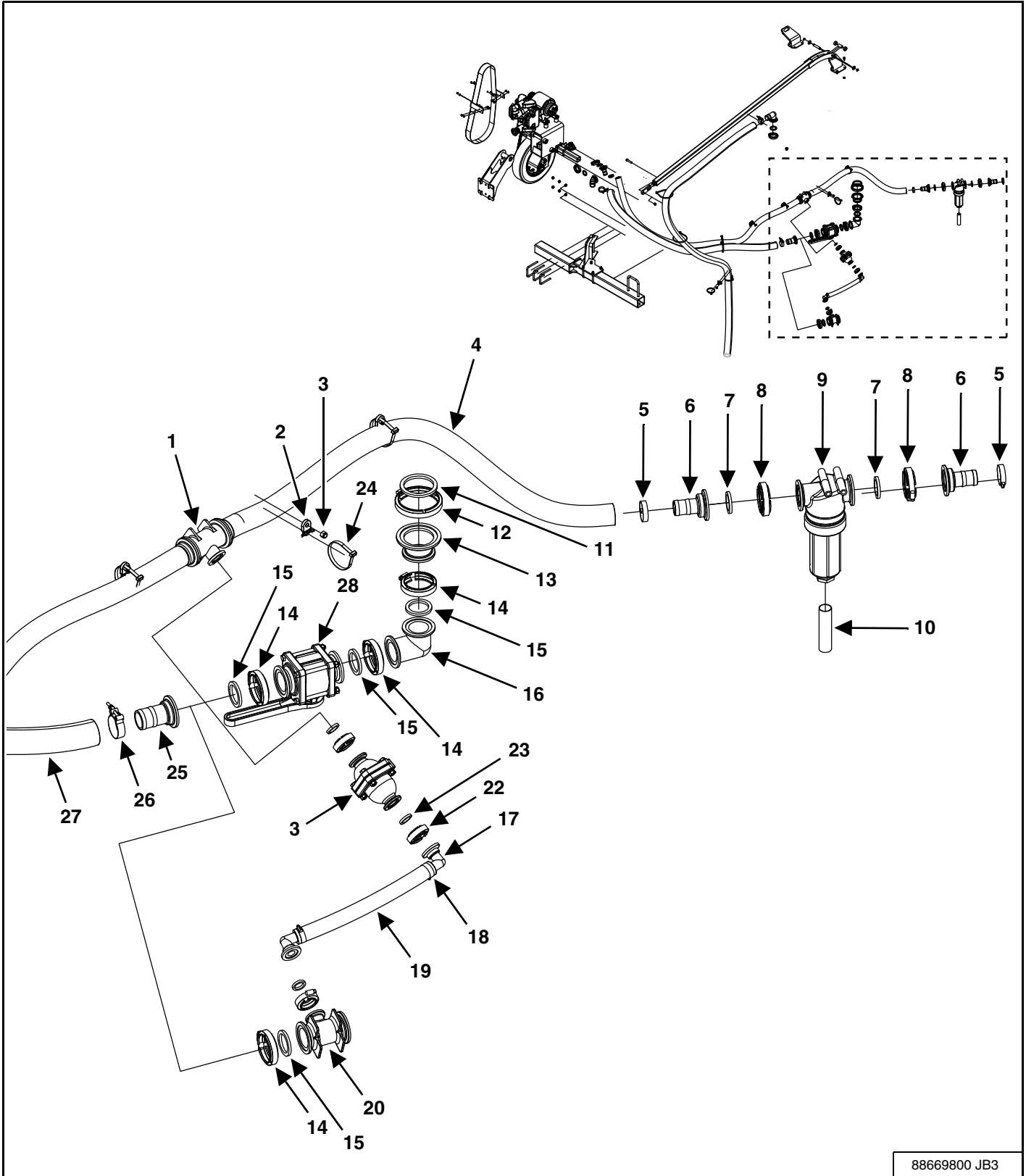

88669800 JB3

ITEM	PART NUMBER	DESCRIPTION	QTY
1	SXM200100TEE	TEE, 2" x 1"	1
2	SX21294	HEAVY DUTY CABLE TIE MOUNT	7
3	SXLN-038-NIYZ	LOCKNUT, 3/8" NYLON INSERT YZ	7
4	88670780	PRODUCT HOSE, 1-1/2"	1
5	SX28J	STAINLESS CLAMP, 1-3/4" x 1/2"	5
6	SXM200150BRB	HOSE BARB, 2" FLG x 1-1/2" HB	5
7	SX150G	FLANGED VALVE GASKET; FOR 2"	6
8	SXFC200BJ	BANJO CLAMP, 2"	4
9	SXMLST150-HB	STRAINER, 2" T-HEAD & BODY, FLGED	1
10	SXLST1550	50 MESH SCREEN, 1-1/4" & 1-1/2" T	1
11	SX300G	BANJO GASKET, 3"	1
12	SXFC300BJ	BANJO CLAMP, 3"	1
13	SXM300220CPG	FLANGE, 3" x 2" FULL PORT RED. FL	1
14	SXFC220	WORM SCREW CLAMP, 2"SERIES	5
15	SX200G	COUPLING GASKET, 2" EPDM	5
16	SXM220CPG90	90 DEG. COUPLING FITTING, 2" FULL PORT	1
17	SXM100BRB90	HOSE BARB, 1" FLANGE ELBOW	2
18	SX20J	STAINLESS CLAMP, 1-1/4" x 1/2"	2
19	88670781	PRODUCT HOSE, 1"	1
20	88669596	PLUMBING TEE, 2" FP x 1"	1
21	88661393	1" PRESSURE SPIKE VALVE, 100 PSI	1
22	SXFC100BJ	CLAMP, 1"	3
23	SXM100G	FLANGED VALVE GASKET, FOR 1"	3
24	SX3NS21	BLACK STRAP, 21-1/2"	9
25	SXM220BRB	HOSE BARB, 2" W / FULL PORT FLG	1
26	SXTBC256	T-BOLT CLAMP, 2-11/32 - 25/8	3
27	88670011	PRODUCT HOSE, 2" SC	1
28	SXMV220CF	BANJO VALVE, 2" FP FLG	1

JOHN BLUE SUB-ASSEMBLY

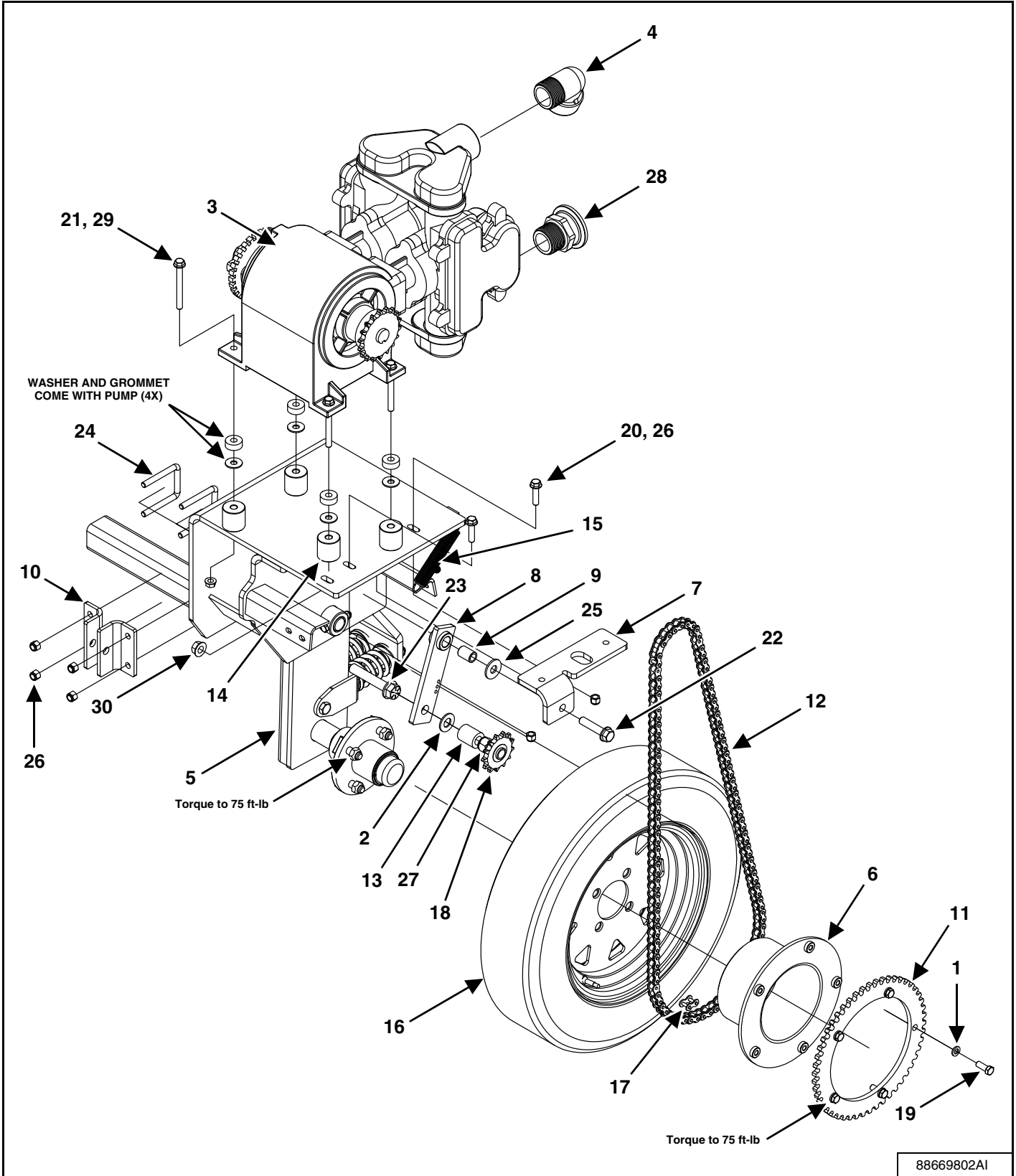

88669802AI

ITEM	PART NUMBER	DESCRIPTION	QTY
1	00080680	LOCKWASHER, 0.375 PL	
2	00087365	FLAT WASHER, SAE 0.62 PL	
3	88660940	DUAL PISTON PUMP	
4	88660945	90° ELBOW, 1-1/2" MPT x 1-1/2" FPT- POLY	
5	88669818	JB PUMP DRIVE MOUNT ASSEMBLY	
6	88669827	HUB ADAPTER WELDMENT	
7	88669862	IDLER BRACKET PLATE, FRMD	
8	88669863	IDLER ARM WELDMENT	
9	88669866	IDLER PIVOT BUSHING	
10	88669898	ADJUSTMENT ANGLE PLATE, FRMD	
11	88670025	JOHN BLUE WHEEL SPROCKET	
12	88670039	ROLLER CHAIN, #50, 114 PITCH	
13	88670181	SPROCKET SPACER TUBE	
14	88670580	PUMP MOUNT SPACER	
15	88670582	EXTENSION SPRING	
16	88670717	JB DRIVE WHEEL ASSEMBLY	
17	SX008053	CONNECTING LINK, #50	
18	SX013520	IDLER SPROCKET, 50-13, 5/8 BORE	
19	SXBH0381005YZ	BOLT 3/8" x 1" YLLW ZNC	
20	SXBHF0381508YZ	BOLT, 3/8" x 1-1/2" FLG GR 8 YLLWZN	
21	SXBHF0383508YZ	BOLT, 3/8" x 3-1/2" FLG GR 8 YLLWZN	
22	SXBHF0502258YZ	BOLT, 1/2" x 2-14" FLG GR 8 YLLW ZN	
23	SXBHF0623508YZ	BOLT, 5/8" x 3-1/2" FLG GR 8 YZ	
24	SXBU0382003002	U-BOLT; 3/8" x 2" x 3" GR 2	
25	SXFW-050YZ	FLATWASHER, 1/2" YZ	
26	SXLN-038-NIYZ	LOCKNUT, 3/8" NYLON INSERT YZ	
27	SXLN-062-NI-YZ	LOCKNUT, 5/8" NYLON INSERT YZ	
28	SXM200150MPT	MANIFOLD, 2" FLG, 1-1/2" MPT	
29	SXNTFTL038168YZ	LOCKNUT, 3/8"-16 UNC FLG TP LCK GR 8 YZ	
30	SXNTFTL050138Y	LOCKNUT, 1/2"-13 TP LCK GR 8	

1 SECTION CONTROL VALVE ASSEMBLY

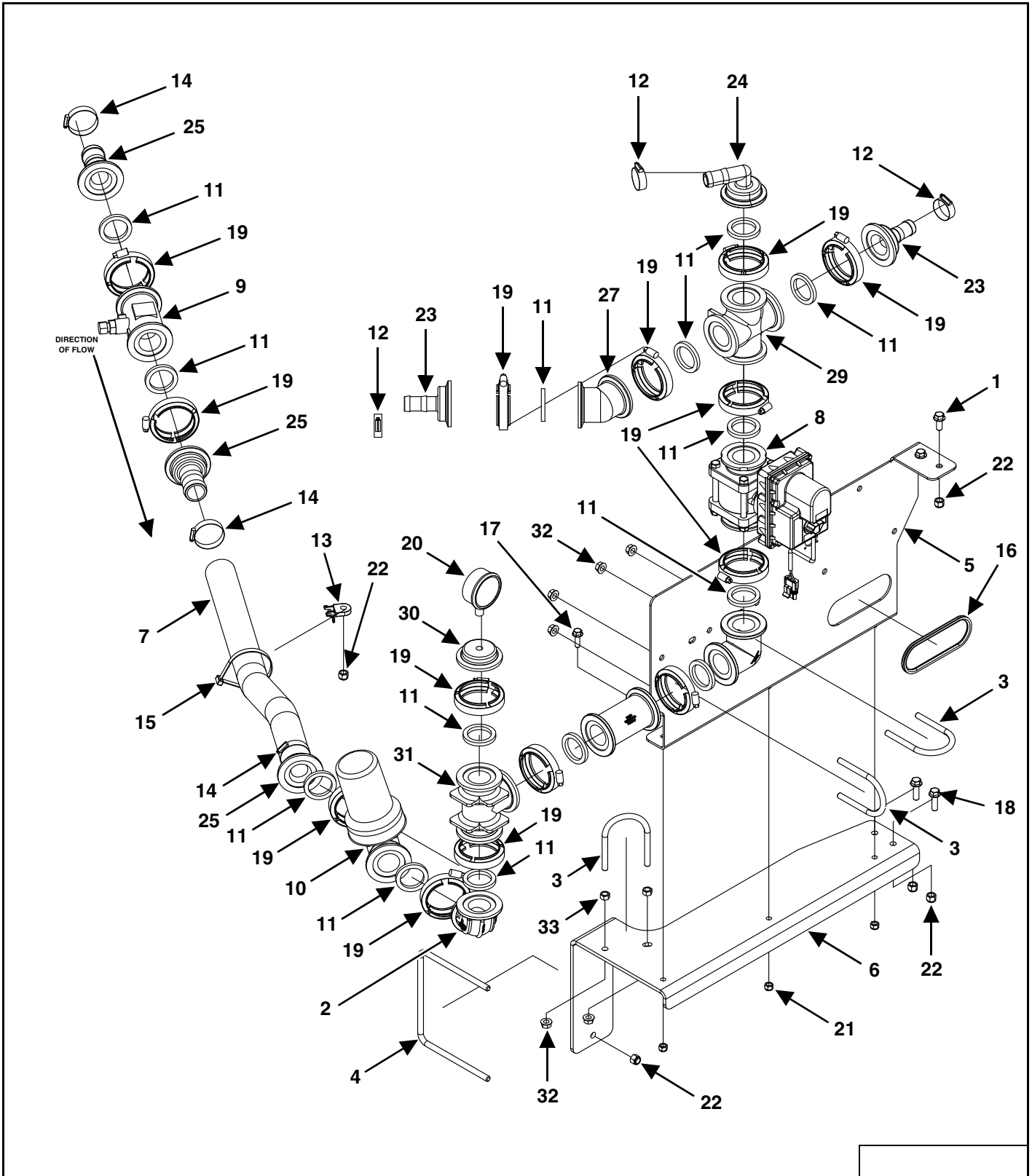

ITEM	PART NUMBER	DESCRIPTION	QTY
1	88662129	BOLT, FLANGE, 3/8" x 1" GR 5	2
2	88667348	90° ELBOW, 2" FLG x 2" FLG, SWP	1
3	88668020	U-BOLT, 3/8" x 2-1/2" x 4" RND YZ	3
4	88669539	U-BOLT, 3/8" x 7" x 6-1/4" GR 5 SQ YZ	1
5	88669550	PLUMBING SECTION BACK PLATE	1
6	88669551	PLUMBING SECTION BOTTOM PLATE	1
7	88669552	HOSE, PRODUCT, 1-1/2"	1
8	SX016663	VALVE, 2" ELEC. BANJO W / PACKARD	1
9	SX063-0171-793	FLOW METER, RFM 60P	1
10	SX063-0172-125	CONTROL VALVE, 1" POLY	1
11	SX150G	GASKET, FOR 2" FLANGED VALVE	14
12	SX20J	CLAMP, 1 1/4" x 1/2" STAINLESS	3
13	SX21294	HEAVY DUTY CABLE TIE MOUNT	1
14	SX28J	CLAMP, 1-3/4" x 1/2" STAINLESS	3
15	SX3NS21	STRAP, BLACK 21-1/2"	1
16	SX9000-0055	GUARD, HOSE GARD SD1205A	1.25'
17	SXBHF0311005YZ	BOLT, 5/16" x 1" FLG GR 5 YLLX ZN	3
18	SXBHF0381258YZ	BOLT, 3/8" x 1" FLG GR 8 YLLWZN	2
19	SXFC200BJ	CLAMP, 2" BANJO	14
20	SXGG100	GAUGE, 2-1/2" LIQ FILLED 100 PSI	1
21	SXLN-031-NIYZ	LOCKNUT, 5/16" NYLON INSERT YZ	3
22	SXLN-038-NIYZ	LOCKNUT, 3/8" NYLON INSERT YZ	7
23	SXM200100BRB	HOSE BARB, 1" FLANGE STRAIGHT	2
24	SXM200100BRB90	HOSE BARB, 1" FLANGE ELBOW	1
25	SXM200150BRB	HOSE BARB, 2" FLG x 1 1/2 HB	3
26	SXM200CPG	FLANGE, 2" x 2" POLY	1
27	SXM200CPG45	45° ELBOW FLANGE 2"	1
28	SXM200CPG90SH	90° ELBOW, 2" x 2" STD PORT FLG	1
29	SXM200CR	CROSS, 2" STANDARD PORT FLG	1
30	SXM200PLG025	PLUG, FLANGE 2" W/1/4 PORT	1
31	SXM200TEE	TEE, 2" FLG, BANJO	1
32	SXNTFTL038168YZ	LOCKNUT, 3/8"-16 UNC FLG TP GR 8 YZ	6
33	SXNUT-038YZ	NUT, 3/8" GR 5	2

3 SECTION CONTROL VALVE ASSEMBLY

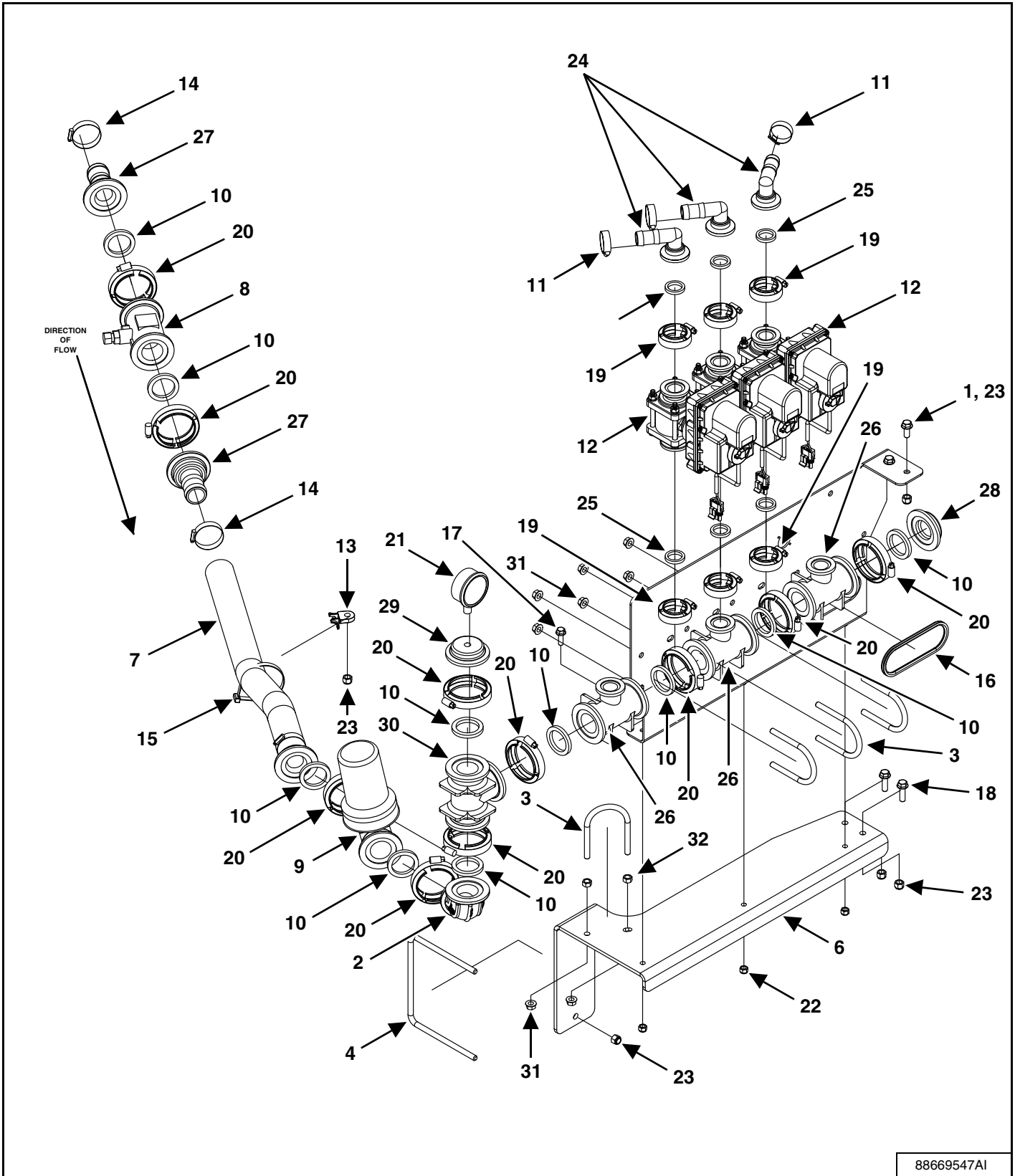

ITEM	PART NUMBER	DESCRIPTION	QTY
1	88662129	BOLT, FLANGE, 3/8" x 1" GR 5	2
2	88667348	90° ELBOW, 2" FLG x 2" FLG, SWP	1
3	88668020	U-BOLT, 3/8" x 2-1/2" x 4" RND YZ	4
4	88669539	U-BOLT, 3/8" x 7" x 6-1/4" GR 5 SQ YZ	1
5	88669550	PLUMBING SECTION BACK PLATE	1
6	88669551	PLUMBING SECTION BOTTOM PLATE	1
7	88669552	HOSE, PRODUCT, 1-1/2"	1
8	SX063-0171-793	FLOW METER, RFM 60P	1
9	SX063-0172-125	CONTROL VALVE, 1" POLY	1
10	SX150G	GASKET, FOR 2" FLANGED VALVE	10
11	SX20J	CLAMP, 1 1/4" x 1/2" STAINLESS	3
12	SX2123683	MANIFOLD 1" VALVE ASSY 1" FL	3
13	SX21294	HEAVY DUTY CABLE TIE MOUNT	1
14	SX28J	CLAMP, 1-3/4" x 1/2" STAINLESS	3
15	SX3NS21	STRAP, BLACK 21-1/2"	1
16	SX9000-0055	GUARD, HOSE GARD SD1205A	1.25'
17	SXBHF0311005YZ	BOLT, 5/16" x 1" FLG GR 5 YLLX ZN	3
18	SXBHF0381258YZ	BOLT, 3/8" x 1" FLG GR 8 YLLWZN	2
19	SXFC100BJ	CLAMP, 1"	6
20	SXFC200BJ	CLAMP, 2" BANJO	10
21	SXGG100	GAUGE, 2-1/2" LIQ FILLED 100 PSI	1
22	SXLN-031-NIYZ	LOCKNUT, 5/16" NYLON INSERT YZ	3
23	SXLN-038-NIYZ	LOCKNUT, 3/8" NYLON INSERT YZ	7
24	SXM100BRB90	HOSE BARB, 1" FLANGE ELBOW	3
25	SXM100G	GASKET, FOR 1" FLANGED VALVE	6
26	SXM200100TEE	TEE, 2" x 1" TEE	3
27	SXM200150BRB	HOSE BARB, 2" FLG x 1 1/2 HB	3
28	SXM200PLG	PLUG, BANJO FLANGE 2"	1
29	SXM200PLG025	PLUG, FLANGE 2" W/1/4 PORT	1
30	SXM200TEE	TEE, 2" FLG, BANJO	1
31	SXNTFTL038168YZ	LOCKNUT, 3/8"-16 UNC FLG TP GR 8 YZ	8
32	SXNUT-038YZ	NUT, 3/8" GR 5	

JB MANIFOLD JUNCTION ASSEMBLY

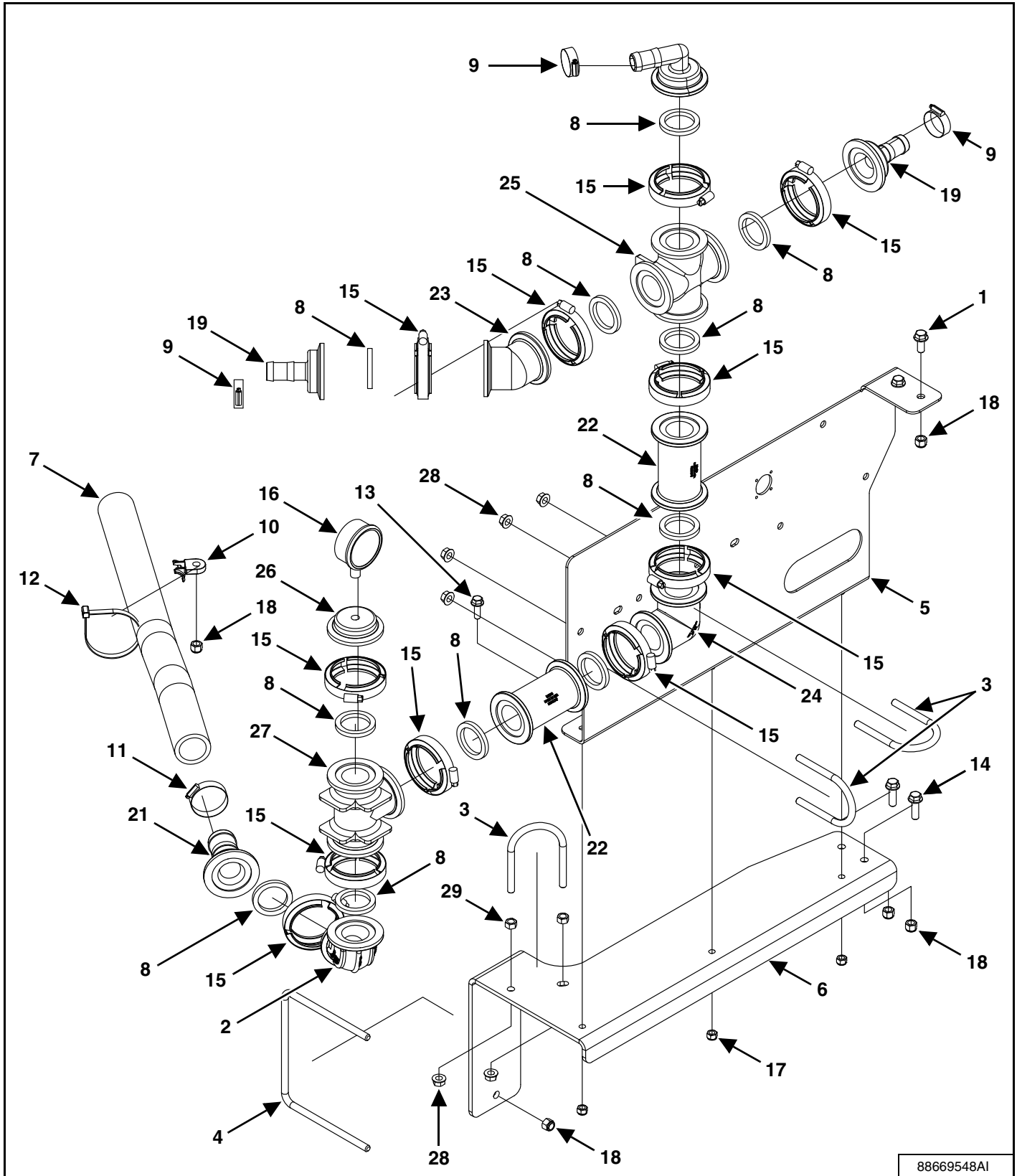

88669548AI

ITEM	PART NUMBER	DESCRIPTION	QTY
1	88662129	BOLT, 3/8" x 1" FLG GR 5	2
2	88667348	90° ELBOW, 2" FLG x 2" FLG, SWP	1
3	88668020	U-BOLT, 3/8" x 2-1/2" x 4" RND YZ	3
4	88669539	U-BOLT, 3/8" x 7" x 6-1/4" GR 5 SQ YZ	1
5	88669550	PLUMBING SECTION BACK PLATE	1
6	88669551	PLUMBING SECTION BOTTOM PLATE	1
7	88669552	HOSE, PRODUCT, 1-1/2"	1
8	SX150G	GASKET, FOR 2" FLANGED VALVE	11
9	SX20J	CLAMP, 1-1/4" x 1/2" STAINLESS	3
10	SX21294	HEAVY DUTY CABLE TIE MOUNT, CABLE TIE HEAVY DUTY	1
11	SX28J	CLAMP, 1-3/4" x 1/2" STAINLESS	1
12	SX3NS21	STRAP, BLACK 21-1/2"	1
13	SXBHF0311005YZ	BOLT, 5/16" x 1" FLG GR 5 YLLX ZN	3
14	SXBHF0381258YZ	BOLT, 3/8" x 1-1/4" FLG GR 8 YLLWZN	2
15	SXFC200BJ	CLAMP, 2" BANJO	11
16	SXGG100	GAUGE, 2-1/2" LIQ FILLED 100 PSI	1
17	SXLN-031-NIYZ	LOCKNUT, 5/16" NYLON INSERT YZ	3
18	SXLN-038-NIYZ	LOCKNUT, 3/8" NYLON INSERT YZ	7
19	SXM200100BRB	HOSE BARB, 2" x 1" STRAIGHT	2
20	SXM200100BRB90	HOSE BARB, 2" x 1" ELBOW 90DG	1
21	SXM200150BRB	HOSE BARB, 2" FLG x 1-1/2" HB	1
22	SXM200CPG	FLANGE, 2" x 2" POLY	2
23	SXM200CPG45	ELBOW FLANGE 2" x 45°	1
24	SXM200CPG90SH	ELBOW, 2" x 2" STD PORT 90° FLG	1
25	SXM200CR	CROSS, 2" STANDARD PORT FLG	1
26	SXM200PLG025	PLUG, FLANGE 2" W / 1/4 PORT	1
27	SXM200TEE	TEE, 2" FLG, BANJO	1
28	SXNTFTL038168YZ	LOCKNUT, 3/8"-16 UNC FLG TP LCK GR 8 YZ	6
29	SXNUT-038YZ	NUT, 3/8" GR 5	2

SUMP MANIFOLD GROUP

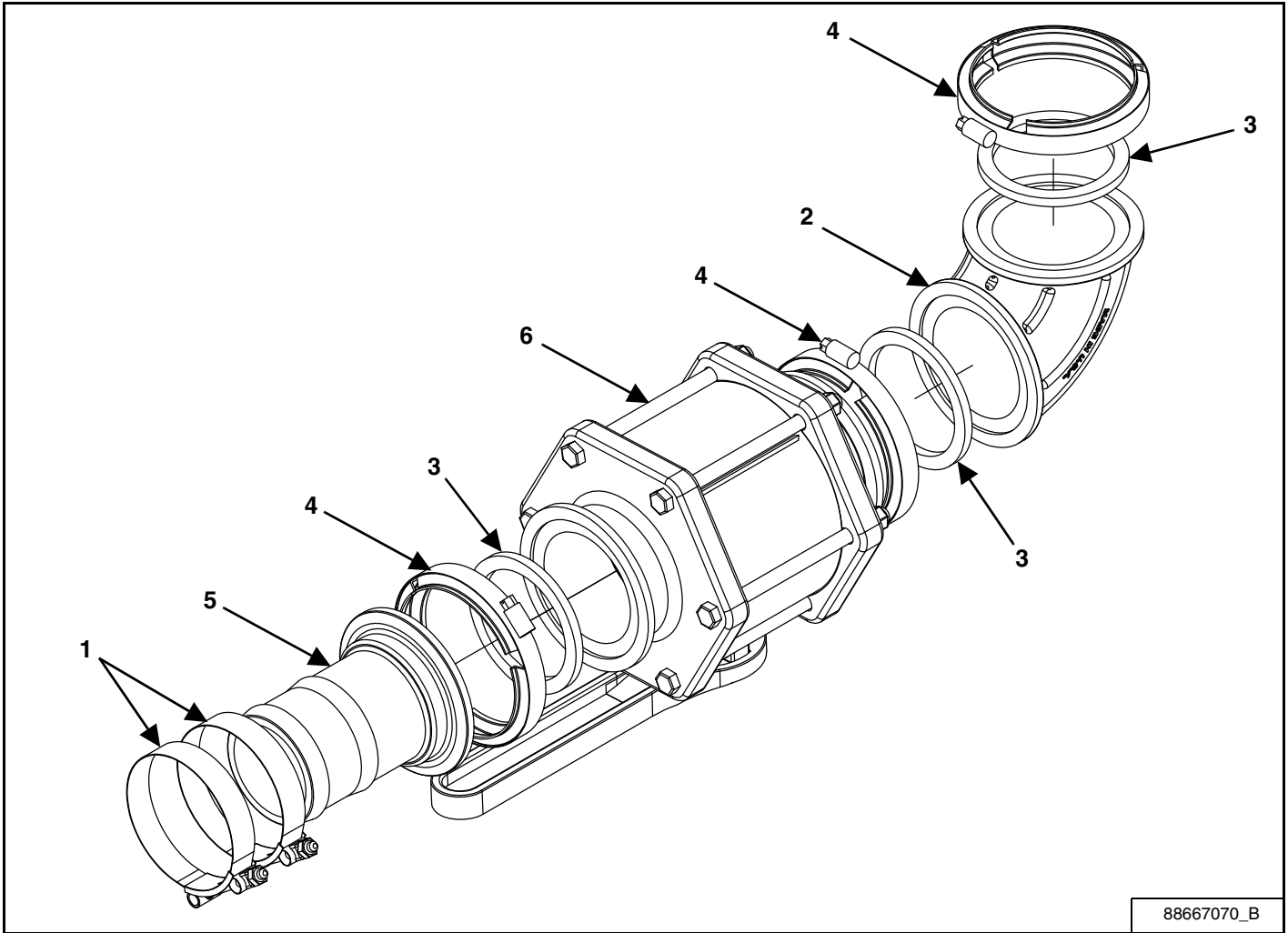

88667070_B

ITEM	PART NUMBER	DESCRIPTION	QTY
1	88669453	CLAMP; T-BOLT 3.50" - 3.81"	2
2	88661663	3" FLANGE x FLANGE SWEEP 90	1
3	SX300G	GASKET, 3" BANJO	3
4	SXFC300BJ	CLAMP, 3" BANJO	3
5	SXM300BRB	HOSE BARB, 3" FLG x 3" HB, POLY	1
6	SXMV300CF	VALVE, 3" FLG x 3" FLG, BALL VALVE	1

QUICK FILL GROUP

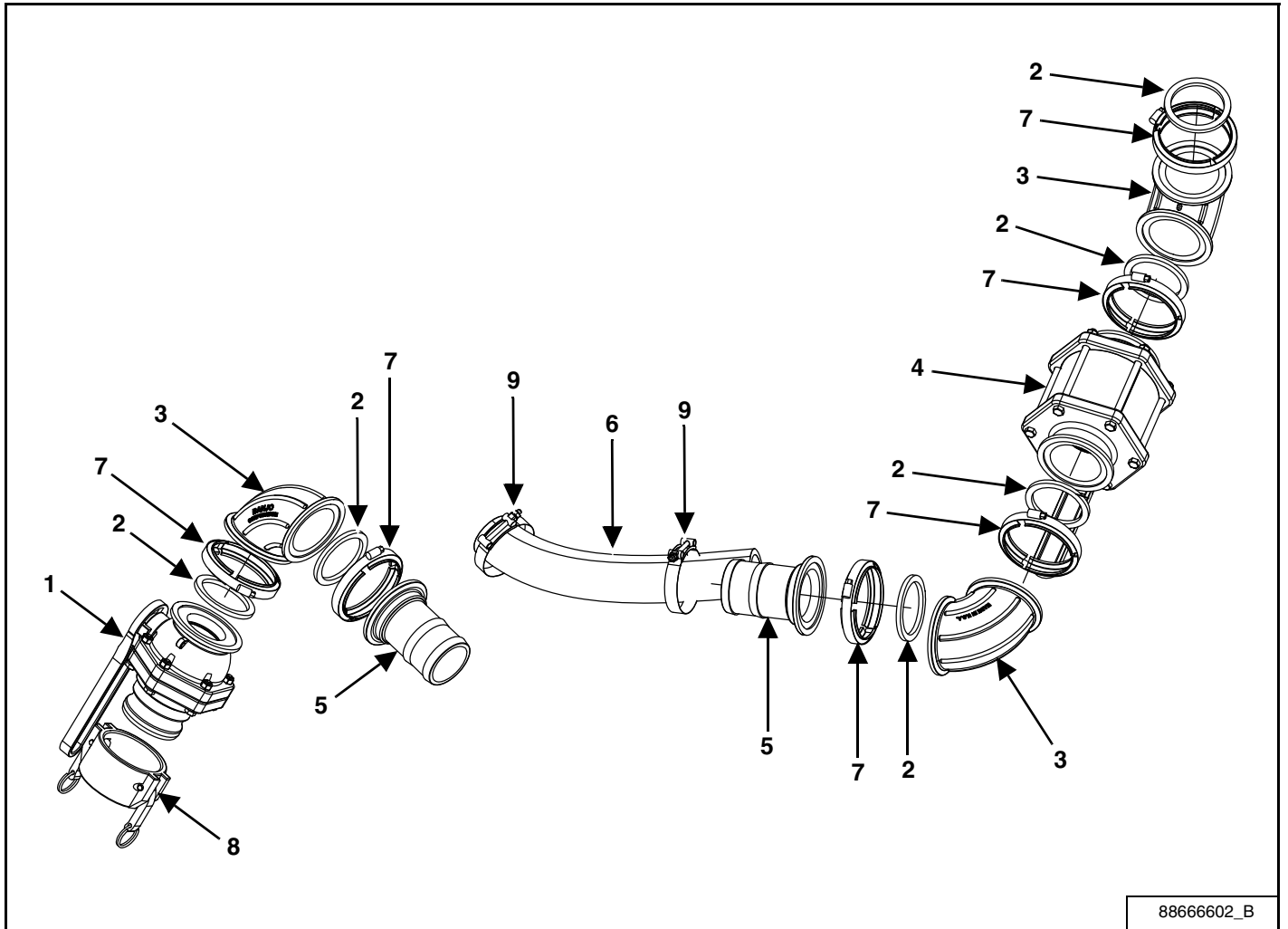

8866602_B

ITEM	PART NUMBER	DESCRIPTION	QTY
1	SXMVSF300	VALVE; 3" FLG x 3" M. ADAPT	1
2	SX300G	GASKET, 3" BANJO	6
3	88661663	3" FLANGE x FLANGE SWEEP 90	3
4	SXMV300CF	VALVE, 3" FLG x 3" FLG, BALL VALVE	1
5	SXM300BRB	HOSE BARB, 3" FLG x 3" HB, POLY	2
6	88667043	HOSE, PRODCUT, SC, 3."	1
7	SXFC300BJ	CLAMP, 3" BANJO	6
8	SX300CAP	COUPLING; 3" CAM LEVER CAP	1
9	88669453	CLAMP; T-BOLT 3.50" - 3.81"	2

TOOLBAR PLUMBING GROUP

Center Section Spray Monitor

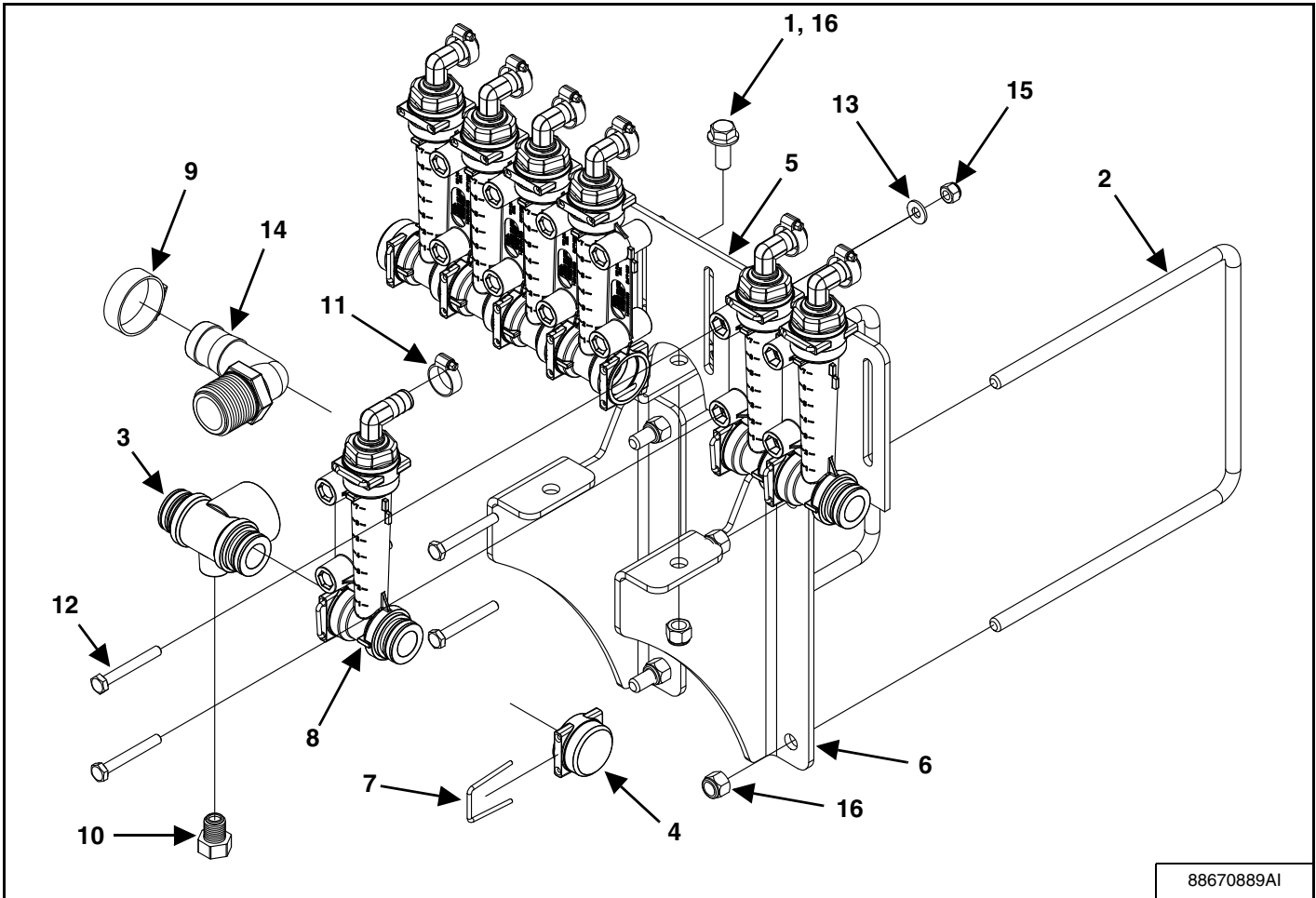

88670889AI

ITEM	PART NUMBER	DESCRIPTION	QTY
1	88662129	BOLT, 3/8" x 1" FLANGE GR 5	2
2	88669540	U-BOLT, 3/8" x 7" x 8-1/4" GR 5 SQ YZ	2
3	88669613	MANIFOLD TEE, 1" FM NPT	1
4	88669614	MONITOR, END CAP	2
5	88670891	PLATE, MONITOR BRACKET, OFFSET	1
6	88669636	PLATE, MONITOR SIDE SHORT	2
7	88669638	MONITOR, RETAINER CLIP	2
8	88670432	ASSEMBLY, MONITOR SINGLE COLUMN	7
9	SX16J	CLAMP, 1" x 1/2" STAINLESS	1
10	SX3F14	PLUG, 1/4" POLY, HEX	1
11	SX6JM	CLAMP, 3/4" HOSE WORM SCREW	7
12	SXBH0252005YZ	BOLT, 1/4" x 2" GRADE 5	14
13	SXFW-025-YZ	FLATWASHER, 1/4" ZINC PLATED	14
14	SXHB-100-90	HOSE BARB ELL, 1" MPT x HB POLY	1
15	SXLN-025-NIYZ	LOCKNUT, 1/4" NYLON INSERT	14
16	SXLN-038-NIYZ	8" NYLON INSERT YZ	6

TOOLBAR PLUMBING GROUP (CONT'D)

Single Column Spray Monitor

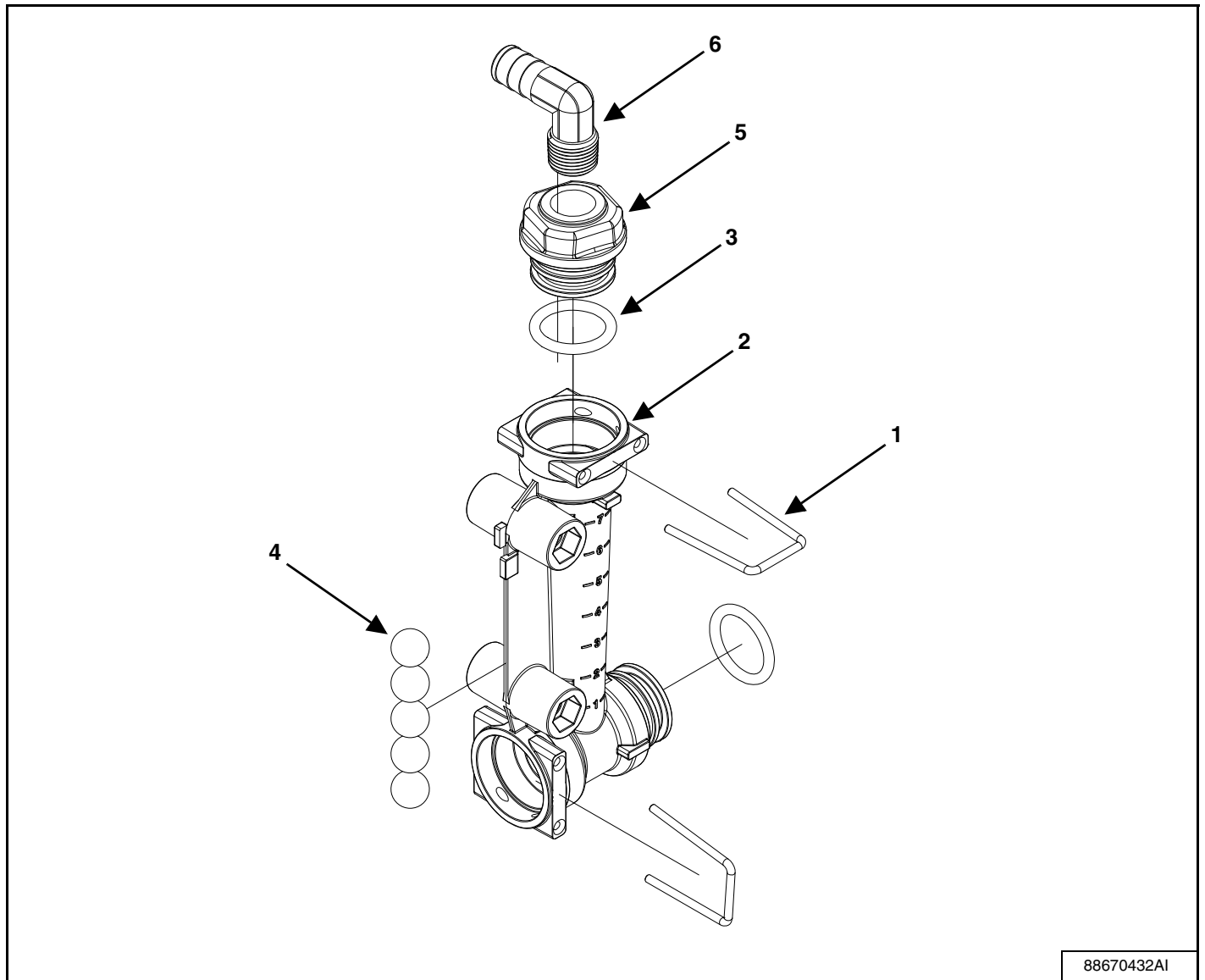

88670432AI

ITEM	PART NUMBER	DESCRIPTION	QTY
1	88669638	MONITOR, RETAINER CLIP	2
2	88670433	BODY, FLOW MONITOR	1
3	88670434	O-RING, #212 VITON	2
4	88670435	REPLACEMENT BALL SET	1
5	88670436	ADAPTER, 3/8" NPT	1
6	88670438	HOSE BARB, 3/8" NPT x 1/2" HB EL	1

TOOLBAR PLUMBING GROUP (CONT'D)

Coulter Injector Hose Assembly

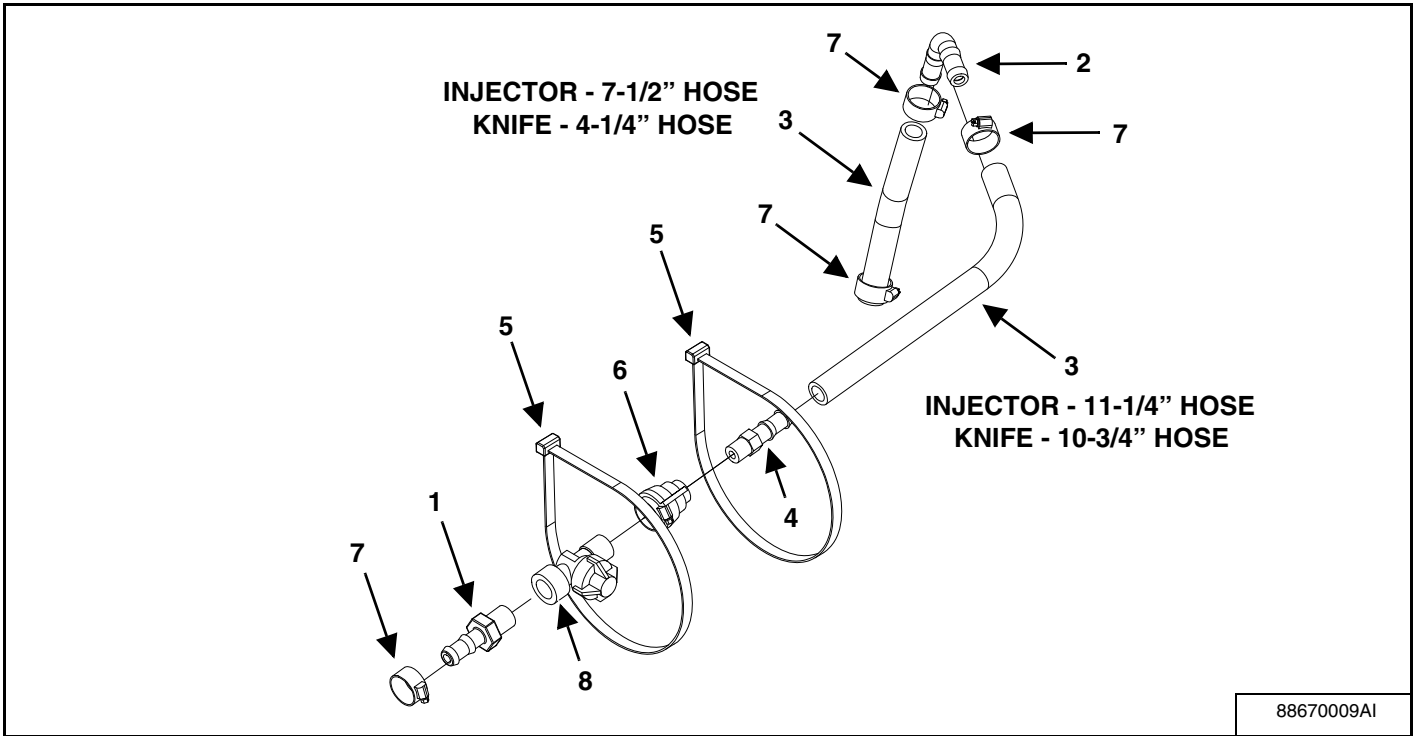

88670009AI

ITEM	PART NUMBER	DESCRIPTION	QTY
1	88661128	HOSE BARB, 11/16" MPST x 1/2" HB	1
2	88665767	HOSE BARB, 1/2" HB x 1/2" HB 90	1
3	SX000812	HOSE, 1/2" 150# EPDM	1.56 FT
4	SX3A1412G	HOSE BARB, 1/4" MPT x 1/2" HB	1
5	SX3NS21	STRAP, BLACK 21-1/2"	6
6	SX402910	CAP & GASKET, QT 1/4" THRD, BLK	1
7	SX8J	CLAMP, 1/2" x 1/2" STAINLESS	5
8	SXQJT8360-NYB	CHECK VALVE DIAPHRAGM	1

Coulter Knife Hose Assembly

ITEM	PART NUMBER	DESCRIPTION	QTY
1	88661128	HOSE BARB, 11/16" MPST x 1/2" HB	1
2	88665767	HOSE BARB, 1/2" HB x 1/2" HB 90	1
3	SX000812	HOSE, 1/2" 150# EPDM	1.25 FT
4	SX3A1412G	HOSE BARB, 1/4" MPT x 1/2" HB	1
5	SX3NS21	STRAP, BLACK 21-1/2"	6
6	SX402910	CAP & GASKET, QT 1/4" THRD, BLK	1
7	SX8J	CLAMP, 1/2" x 1/2" STAINLESS	5
8	SXQJT8360-NYB	CHECK VALVE DIAPHRAGM	1

COULTER BRACKET GROUP

16 Row - 20" Spacing 17 Coulters

NOTE: TORQUE ALL TOOLBAR MOUNTING U-BOLTS TO 50 FT / LBS (67.5 N•m).

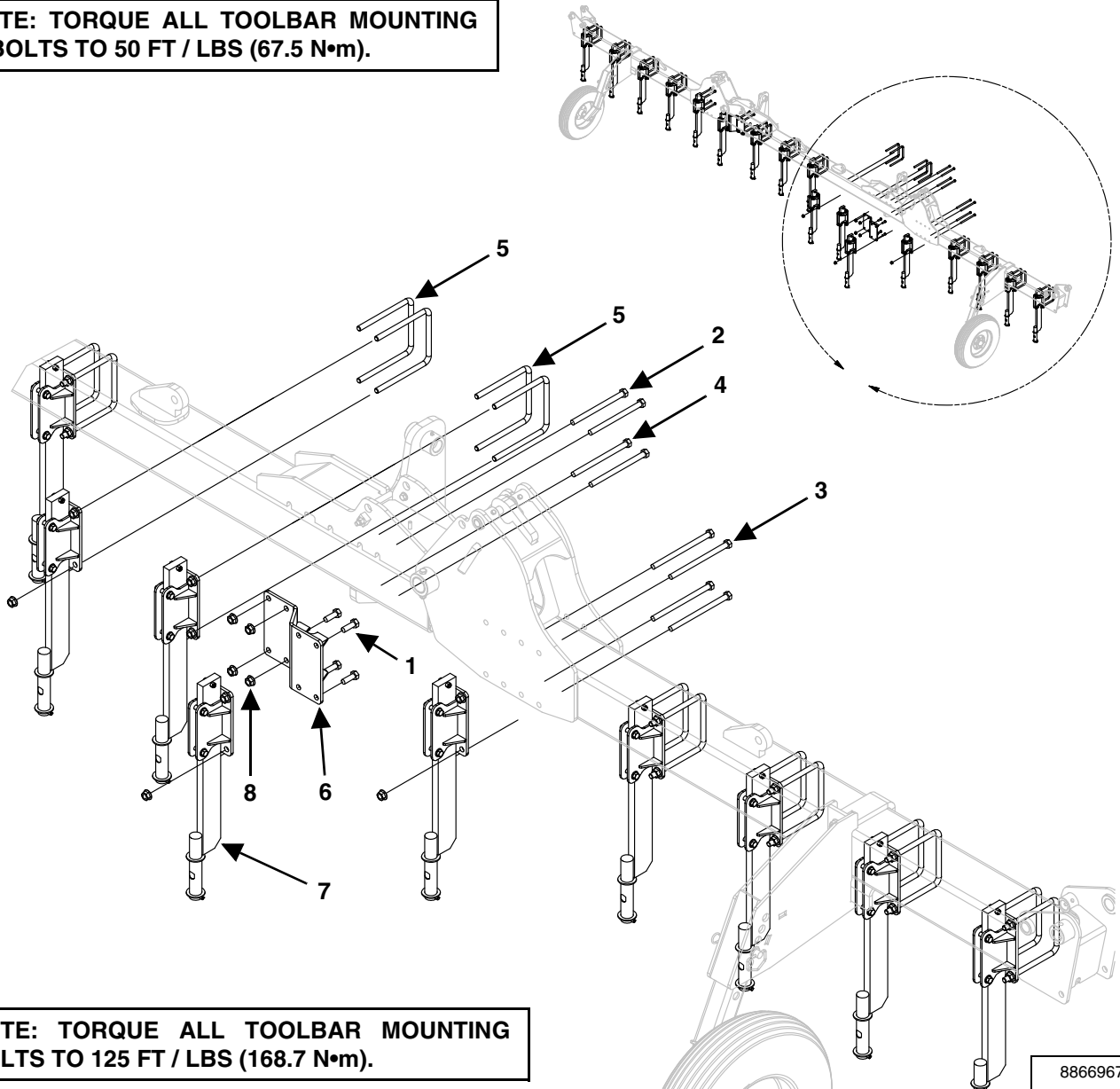

ITEM	PART NUMBER	DESCRIPTION	QTY
1	09627896	BOLT 0.62" x 1-3/4" HEX GR 5 PL	8
2	86507001	BOLT, 5/8-11 x 8-1/2" HEX, GR 5 YZ	4
3	86509114	BOLT, HEX, 5/8-11 x 9-1/2" HEX, GR 5 YZ	8
4	86622984	BOLT, 5/8-11 x 9" HEX, GR 5 YZ	4
5	88669054	U-BOLT, 5/8" x 7" x 8-1/2" GR 5 SQ YZ	26
6	88669142	WELDMENT, COULTER OFFSET LONG	2
7	88669448	ASSEMBLY, COULTER TALL STANDARD	17
8	SXNTFTL062118Y	NUT, 5/8-11 FLG, GR 8	8

COULTER BRACKET GROUP (CONT'D)

16 / 18 Row - 20" Spacing 17 / 19 Coulters

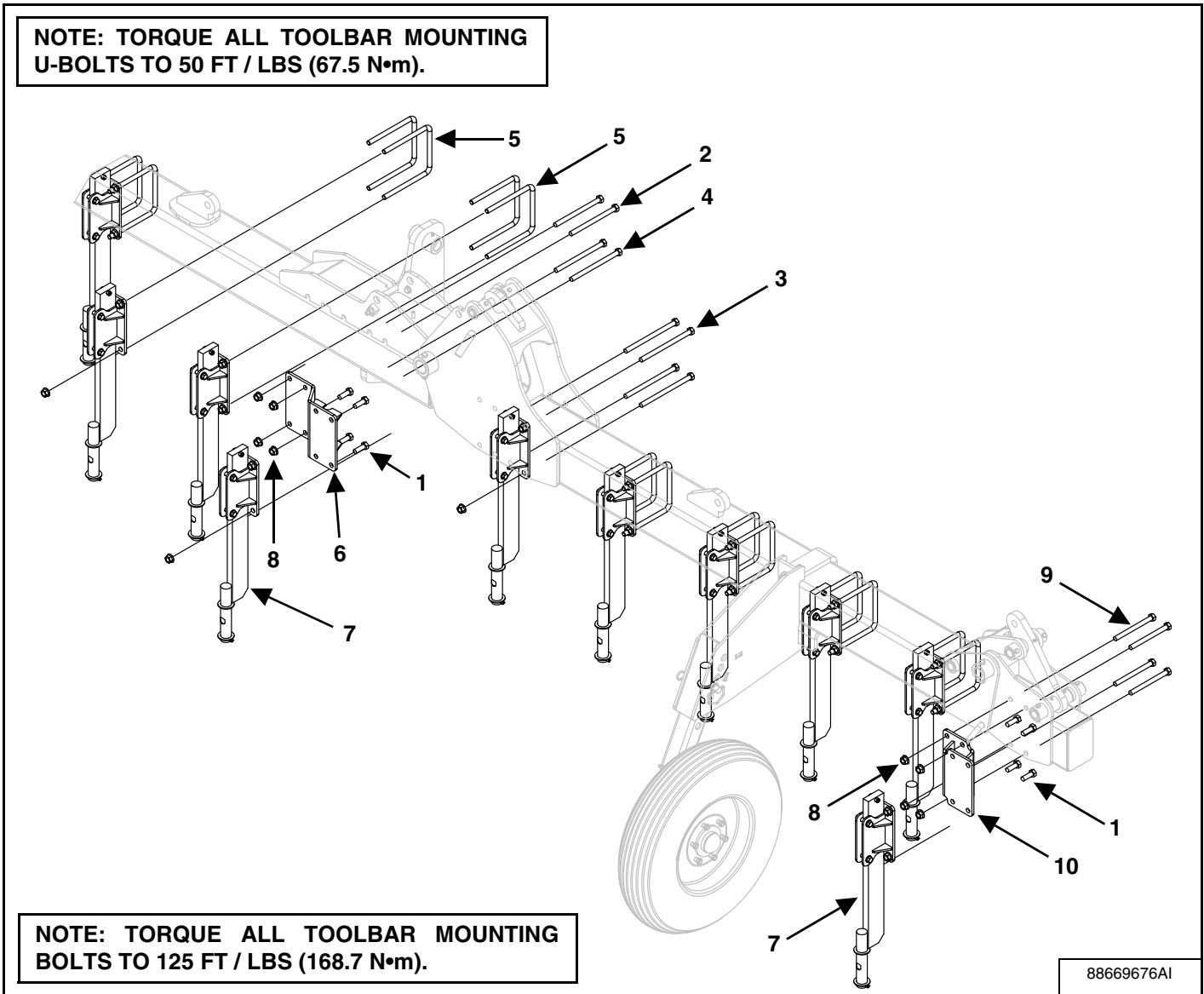

ITEM	PART NUMBER	DESCRIPTION	QTY
1	09627896	BOLT 0.62" x 1-3/4" HEX GR 5 PL	16
2	86507001	BOLT, 5/8-11 x 8-1/2" HEX, GR 5 YZ	4
3	86509114	BOLT, HEX, 5/8-11 x 9-1/2" HEX, GR 5 YZ	8
4	86622984	BOLT, 5/8-11 x 9" HEX, GR 5 YZ	4
5	88669054	U-BOLT, 5/8" x 7" x 8-1/2" GR 5 SQ YZ	26
6	88669142	LONG OFFSET COULTER WELDMENT	2
7	88669448	ASSEMBLY, COULTER TALL STANDARD	19
8	SXNTFTL062118Y	NUT, 5/8-11 FLG, GR 8	16
9	00280293	BOLT, 5/8-11 x 7" HEX, GR 5 YZ	8
10	88669143	SHORT OFFSET COULTER WELDMENT	2

COULTER BRACKET GROUP (CONT'D)

16 / 24 Row - 20" Spacing 17 / 25 Coulters

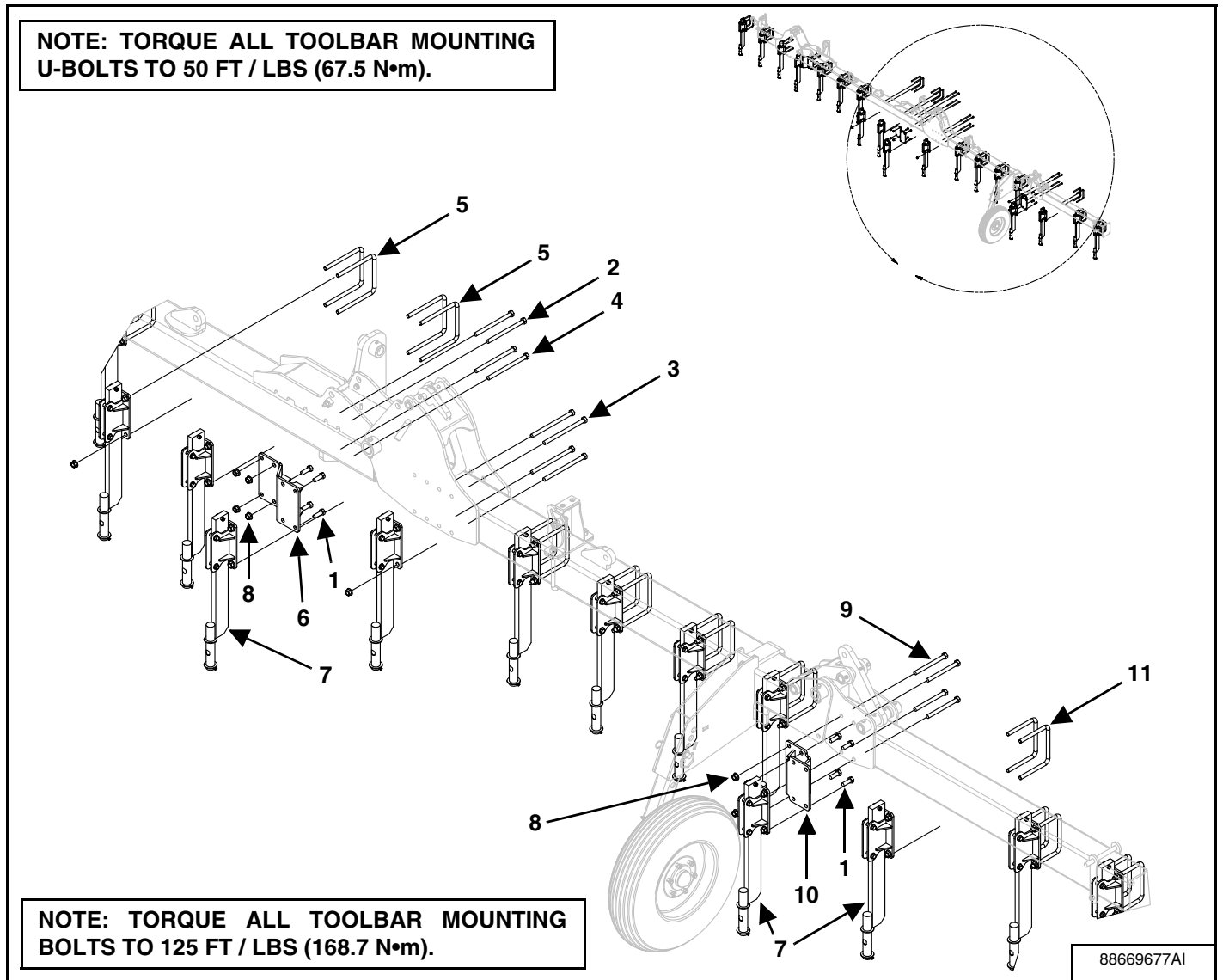

ITEM	PART NUMBER	DESCRIPTION	QTY
1	09627896	BOLT 0.62" x 1-3/4" HEX GR 5 PL	16
2	86507001	BOLT, 5/8-11 x 8-1/2" HEX, GR 5 YZ	4
3	86509114	BOLT, HEX, 5/8-11 x 9-1/2" HEX, GR 5 YZ	8
4	86622984	BOLT, 5/8-11 x 9" HEX, GR 5 YZ	4
5	88669054	U-BOLT, 5/8" x 7" x 8-1/2" GR 5 SQ YZ	26
6	88669142	LONG OFFSET COULTER WELDMENT	2
7	88669448	ASSEMBLY, COULTER TALL STANDARD	25
8	SXNTFTL062118Y	NUT, 5/8-11 FLG, GR 8	16
9	00280293	BOLT, 5/8-11 x 7" HEX, GR 5 YZ	8
10	88669143	SHORT OFFSET COULTER WELDMENT	2
11	88669377	U-BOLT, 5/8" x 7" x 6-1/2" GR 5 SQ YZ	12

COULTER BRACKET GROUP (CONT'D)

18 / 24 Row - 20" Spacing 19 / 25 Coulters

NOTE: TORQUE ALL TOOLBAR MOUNTING U-BOLTS TO 50 FT / LBS (67.5 N•m).

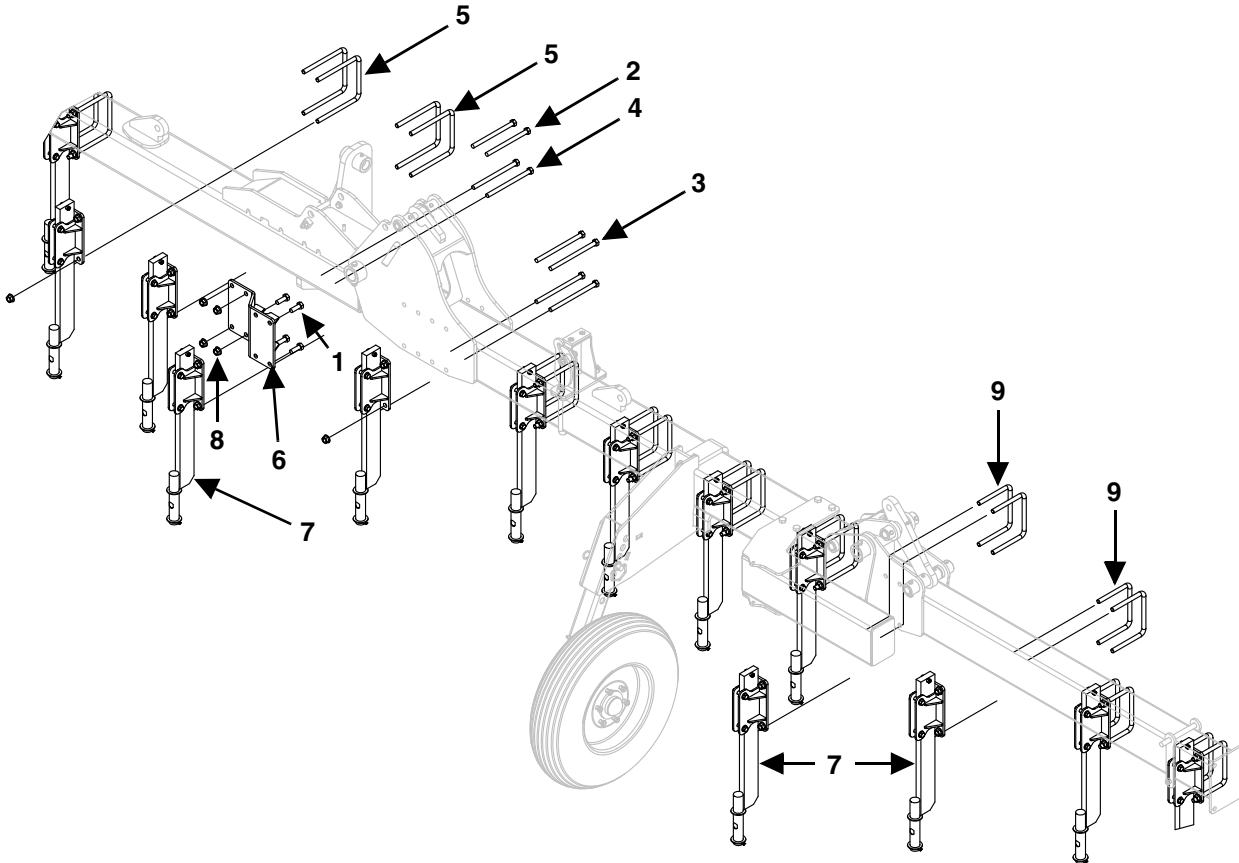

NOTE: TORQUE ALL TOOLBAR MOUNTING BOLTS TO 125 FT / LBS (168.7 N•m).

88669678AI

ITEM	PART NUMBER	DESCRIPTION	QTY
1	09627896	BOLT 0.62" x 1-3/4" HEX GR 5 PL	8
2	86507001	BOLT, 5/8-11 x 8-1/2" HEX, GR 5 YZ	4
3	86509114	BOLT, HEX, 5/8-11 x 9-1/2" HEX, GR 5 YZ	8
4	86622984	BOLT, 5/8-11 x 9" HEX, GR 5 YZ	4
5	88669054	U-BOLT, 5/8" x 7" x 8-1/2" GR 5 SQ YZ	26
6	88669142	LONG OFFSET COULTER WELDMENT	2
7	88669448	ASSEMBLY, COULTER TALL STANDARD	25
8	SXNTFTL062118Y	NUT, 5/8-11 FLG, GR 8	8
9	88669377	U-BOLT, 5/8" x 7" x 6-1/2" GR 5 SQ YZ	16

COULTER BRACKET GROUP (CONT'D)

14 Row - 22" Spacing 15 Coulters

NOTE: TORQUE ALL TOOLBAR MOUNTING U-BOLTS TO 50 FT / LBS (67.5 N•m).

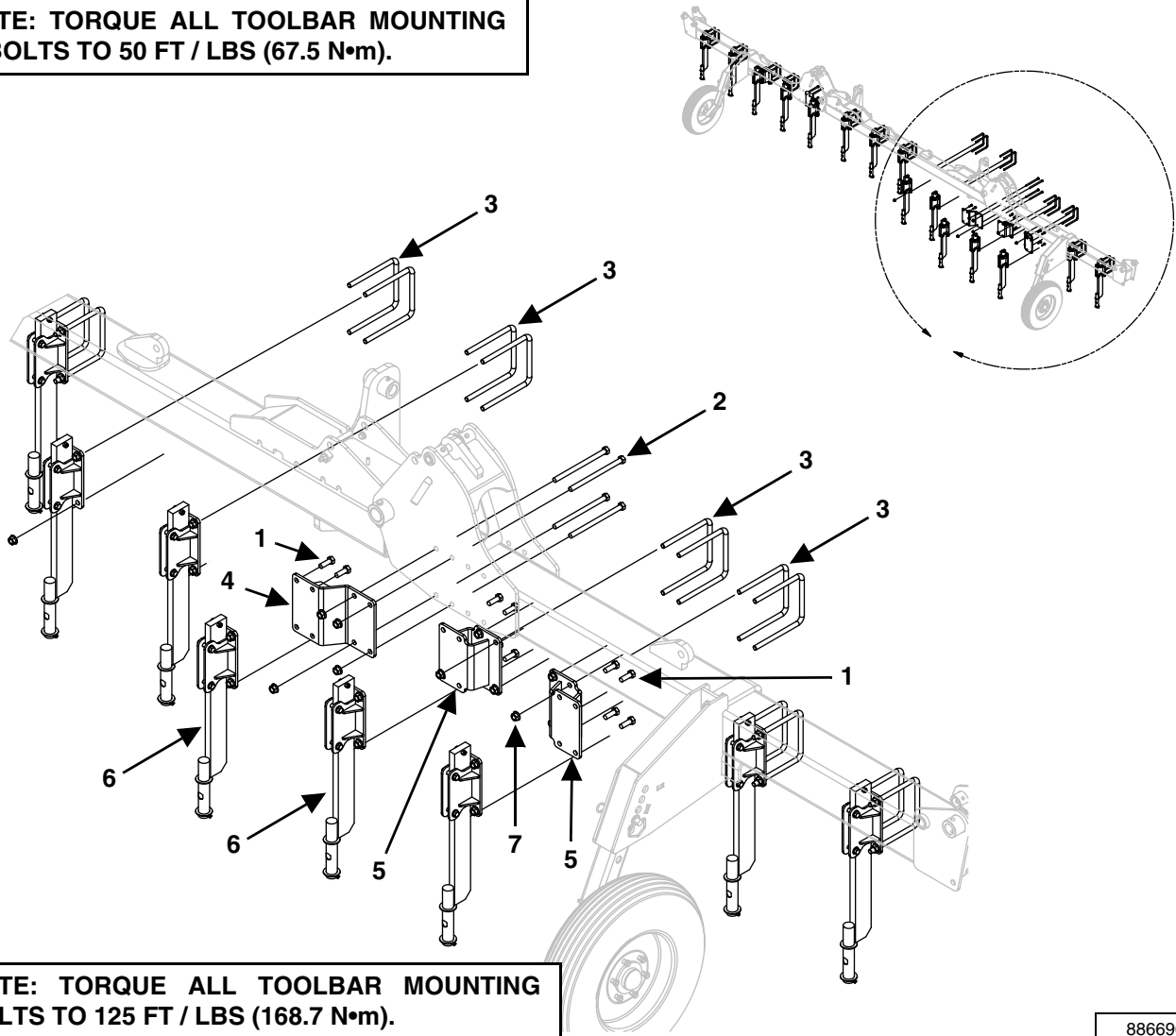

88669679A1

ITEM	PART NUMBER	DESCRIPTION	QTY
1	09627896	BOLT 0.62" x 1-3/4" HEX GR 5 PL	24
2	86509114	BOLT, HEX, 5/8-11 x 9-1/2" HEX, GR 5 YZ	8
3	88669054	U-BOLT, 5/8" x 7" x 8-1/2" GR 5 SQ YZ	26
4	88669142	LONG OFFSET COULTER WELDMENT	2
5	88669143	SHORT OFFSET COULTER WELDMENT	4
6	88669448	ASSEMBLY, COULTER TALL STANDARD	15
7	SXNTFTL062118Y	NUT, 5/8-11 FLG, GR 8	24

COULTER BRACKET GROUP (CONT'D)

14 / 16 Row - 22" Spacing 15 / 17 Coulters

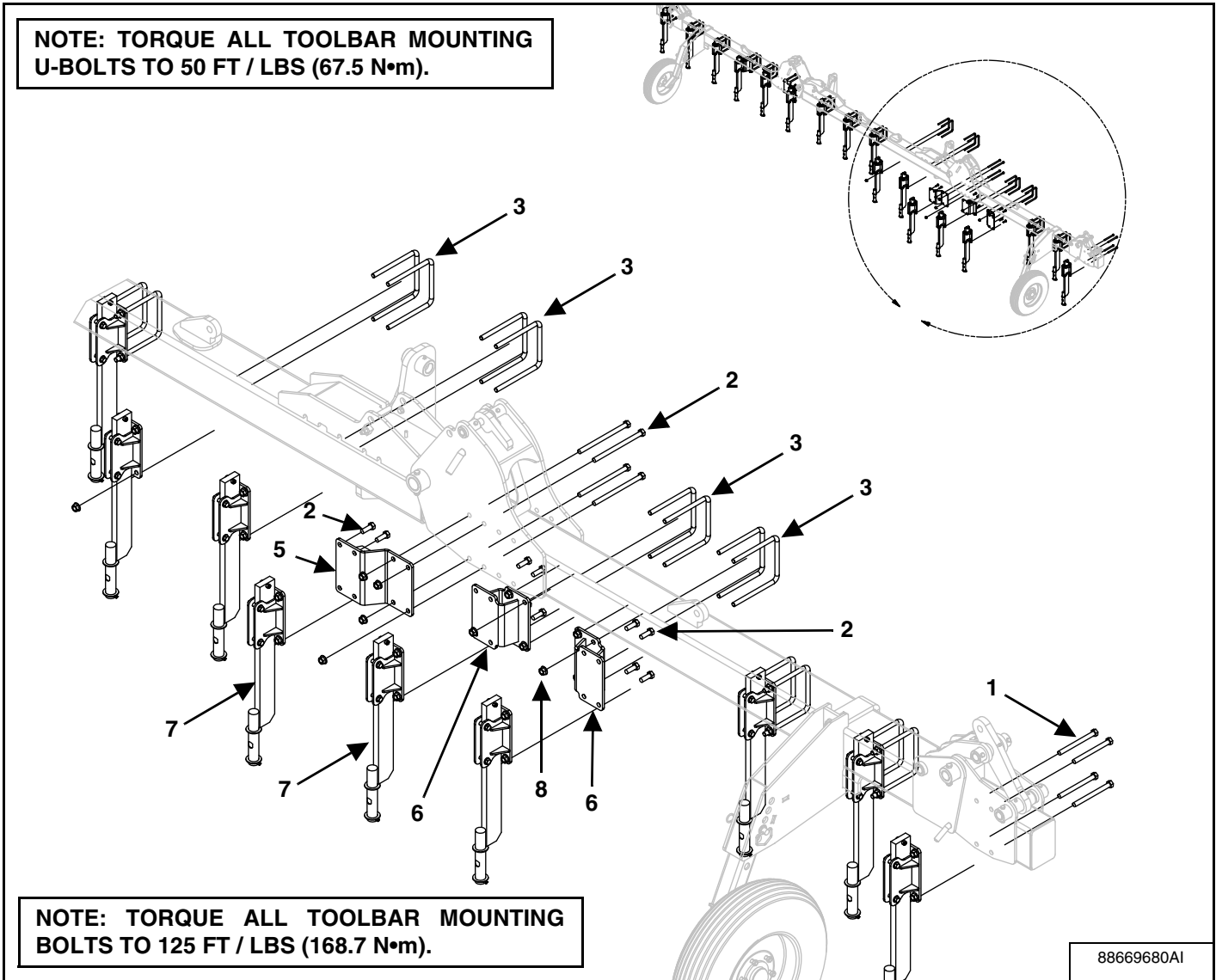

ITEM	PART NUMBER	DESCRIPTION	QTY
1	00280293	BOLT, 5/8-11 x 7" HEX, GR 5 YZ	8
2	09627896	BOLT 0.62" x 1-3/4" HEX GR 5 PL	24
3	86509114	BOLT, HEX, 5/8-11 x 9-1/2" HEX, GR 5 YZ	8
4	88669054	U-BOLT, 5/8" x 7" x 8-1/2" GR 5 SQ YZ	26
5	88669142	LONG OFFSET COULTER WELDMENT	2
6	88669143	SHORT OFFSET COULTER WELDMENT	4
7	88669448	ASSEMBLY, COULTER TALL STANDARD	17
8	SXNTFTL062118Y	NUT, 5/8-11 FLG, GR 8	24

COULTER BRACKET GROUP (CONT'D)

14 / 18 Row - 22" Spacing 15 / 19 Coulters

NOTE: TORQUE ALL TOOLBAR MOUNTING U-BOLTS TO 50 FT / LBS (67.5 N•m).

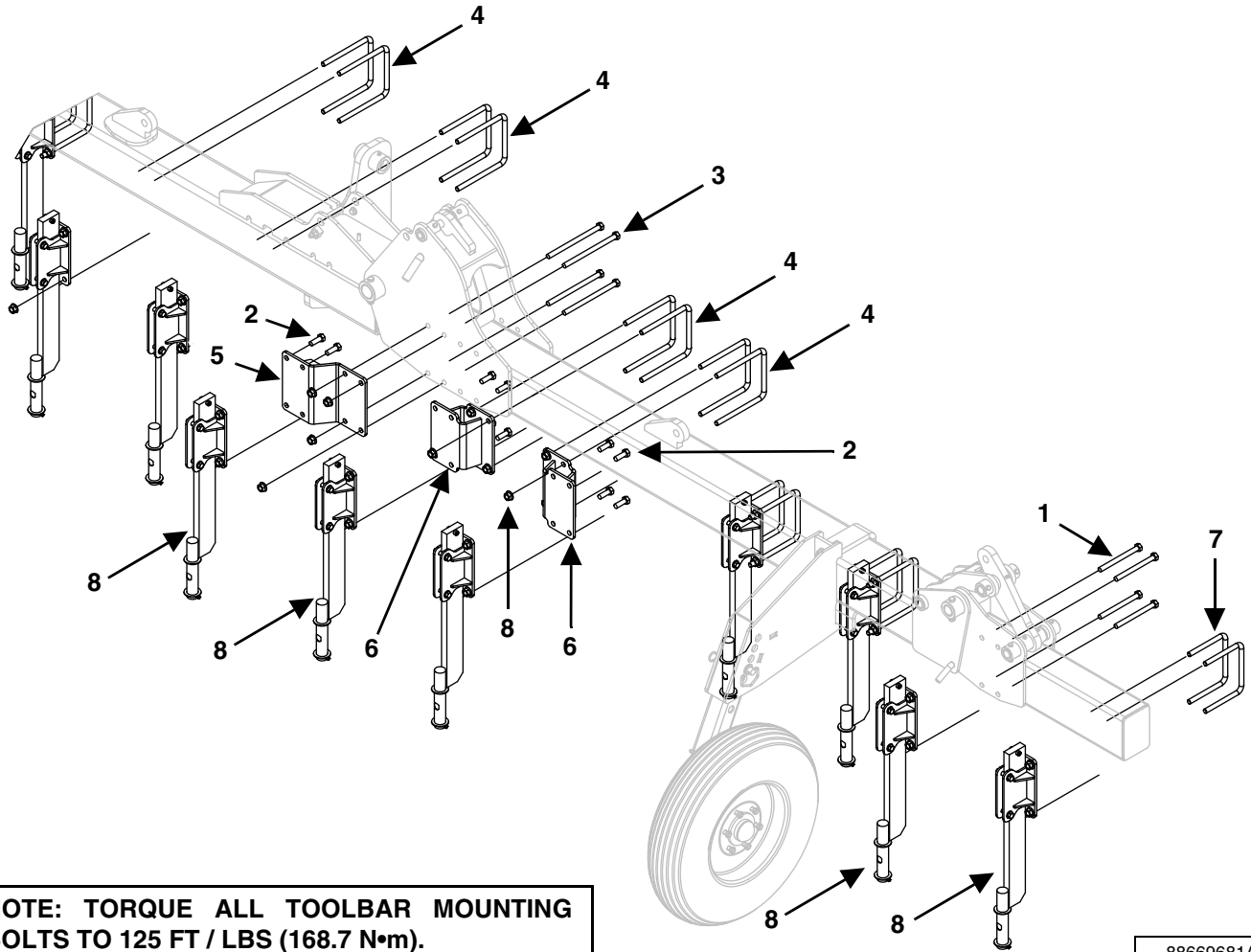

ITEM	PART NUMBER	DESCRIPTION	QTY
1	00280293	BOLT, 5/8-11 x 7" HEX, GR 5 YZ	8
2	09627896	BOLT 0.62" x 1-3/4" HEX GR 5 PL	24
3	86509114	BOLT, HEX, 5/8-11 x 9-1/2" HEX, GR 5 YZ	8
4	88669054	U-BOLT, 5/8" x 7" x 8-1/2" GR 5 SQ YZ	26
5	88669142	LONG OFFSET COULTER WELDMENT	2
6	88669143	SHORT OFFSET COULTER WELDMENT	4
7	88669377	U-BOLT, 5/8" x 7" x 6-1/2" GR 5 SQ YZ	4
8	88669448	ASSEMBLY, COULTER TALL STANDARD	19
9	SXNTFTL062118Y	NUT, 5/8-11 FLG, GR 8	24

COULTER BRACKET GROUP (CONT'D)

14 / 24 Row - 22" Spacing 15 / 25 Coulters

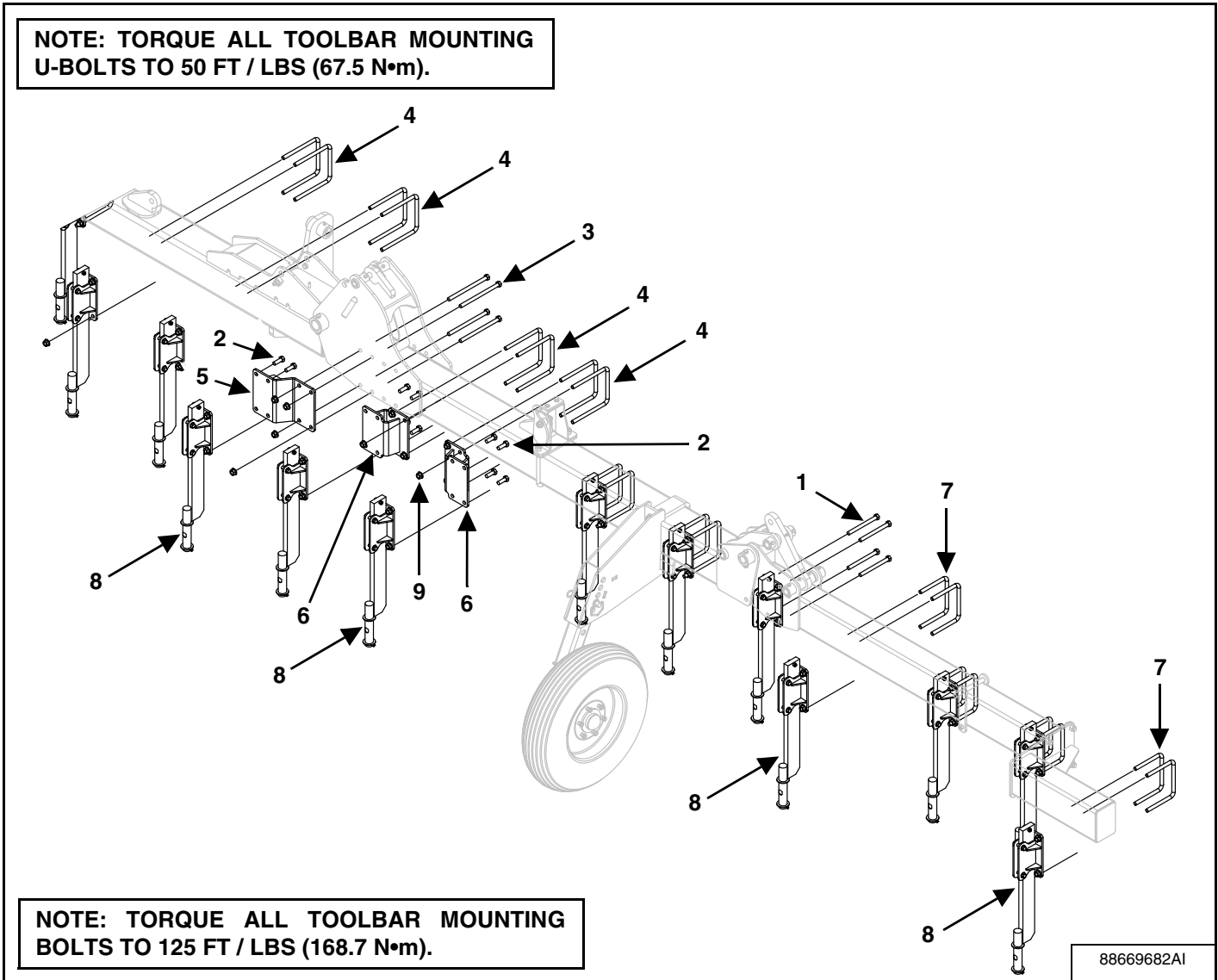

ITEM	PART NUMBER	DESCRIPTION	QTY
1	00280293	BOLT, 5/8-11 x 7" HEX, GR 5 YZ	8
2	09627896	BOLT 0.62" x 1-3/4" HEX GR 5 PL	24
3	86509114	BOLT, HEX, 5/8-11 x 9-1/2" HEX, GR 5 YZ	8
4	88669054	U-BOLT, 5/8" x 7" x 8-1/2" GR 5 SQ YZ	26
5	88669142	LONG OFFSET COULTER WELDMENT	2
6	88669143	SHORT OFFSET COULTER WELDMENT	4
7	88669377	U-BOLT, 5/8" x 7" x 6-1/2" GR 5 SQ YZ	16
8	88669448	ASSEMBLY, COULTER TALL STANDARD	25
9	SXNTFTL062118Y	NUT, 5/8-11 FLG, GR 8	24

COULTER BRACKET GROUP (CONT'D)

16 / 24 Row - 22" Spacing 17 / 25 Coulters

NOTE: TORQUE ALL TOOLBAR MOUNTING U-BOLTS TO 50 FT / LBS (67.5 N•m).

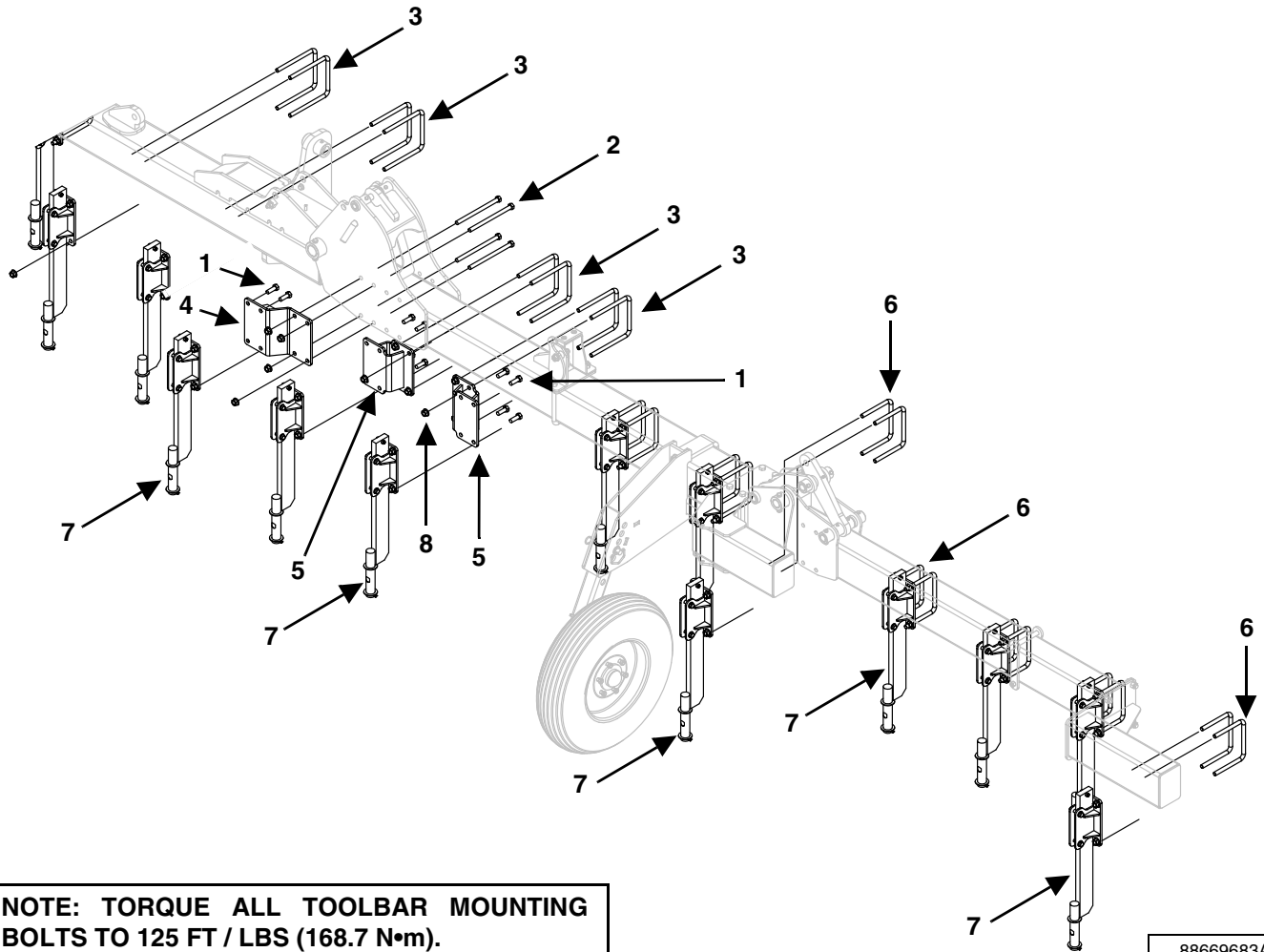

NOTE: TORQUE ALL TOOLBAR MOUNTING BOLTS TO 125 FT / LBS (168.7 N•m).

88669683AI

ITEM	PART NUMBER	DESCRIPTION	QTY
1	09627896	BOLT 0.62" x 1-3/4" HEX GR 5 PL	24
2	86509114	BOLT, HEX, 5/8-11 x 9-1/2" HEX, GR 5 YZ	8
3	88669054	U-BOLT, 5/8" x 7" x 8-1/2" GR 5 SQ YZ	26
4	88669142	LONG OFFSET COULTER WELDMENT	2
5	88669143	SHORT OFFSET COULTER WELDMENT	4
6	88669377	U-BOLT, 5/8" x 7" x 6-1/2" GR 5 SQ YZ	20
7	88669448	ASSEMBLY, COULTER TALL STANDARD	25
8	SXNTFTL062118Y	NUT, 5/8-11 FLG, GR 8	24

COULTER BRACKET GROUP (CONT'D)

18 / 24 Row - 22" Spacing 19 / 25 Coulters

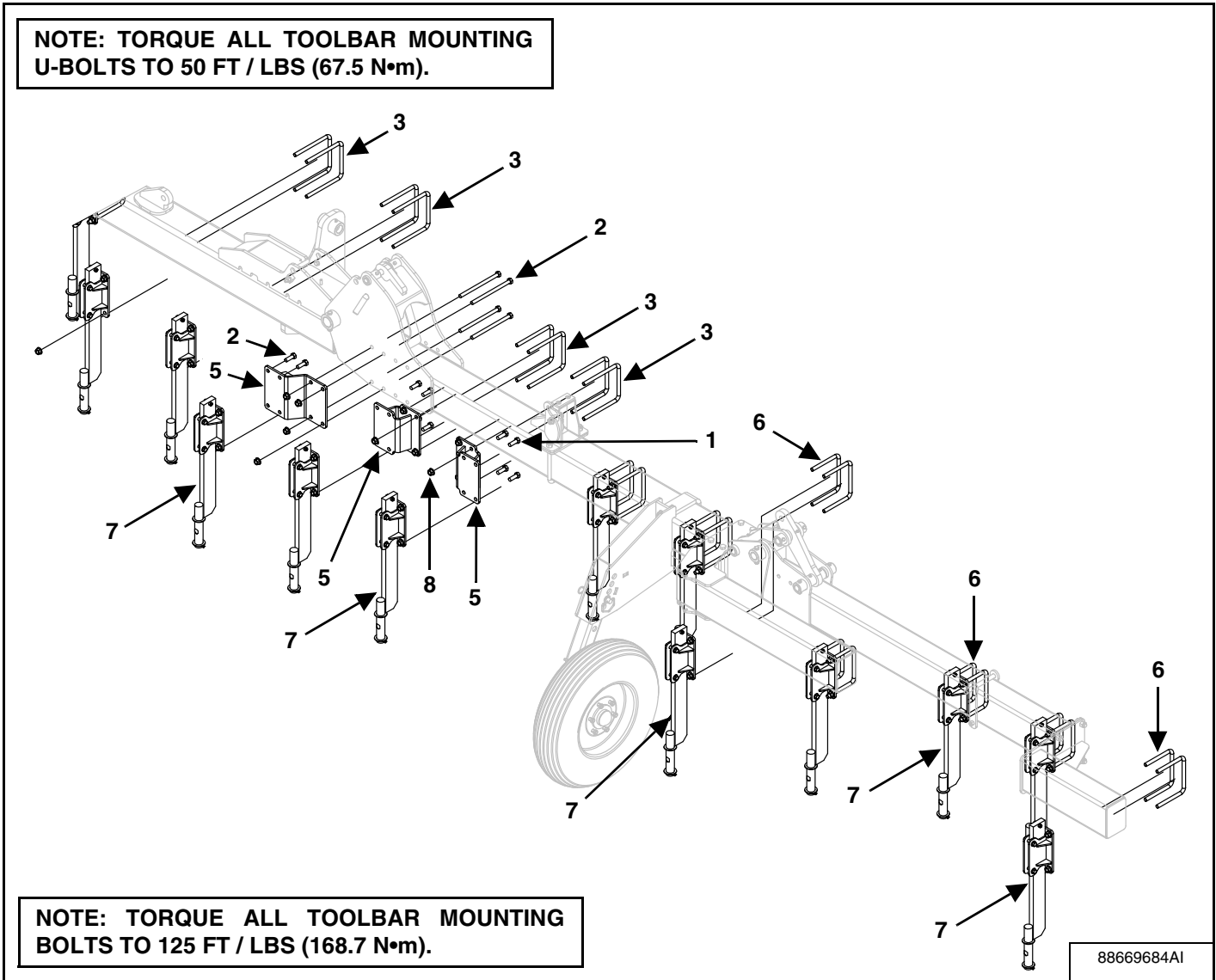

ITEM	PART NUMBER	DESCRIPTION	QTY
1	09627896	BOLT 0.62" x 1-3/4" HEX GR 5 PL	24
2	86509114	BOLT, HEX, 5/8-11 x 9-1/2" HEX, GR 5 YZ	8
3	88669054	U-BOLT, 5/8" x 7" x 8-1/2" GR 5 SQ YZ	26
4	88669142	LONG OFFSET COULTER WELDMENT	2
5	88669143	SHORT OFFSET COULTER WELDMENT	4
6	88669377	U-BOLT, 5/8" x 7" x 6-1/2" GR 5 SQ YZ	20
7	88669448	ASSEMBLY, COULTER TALL STANDARD	25
8	SXNTFTL062118Y	NUT, 5/8-11 FLG, GR 8	24

COULTER BRACKET GROUP (CONT'D)

10 / 12 Row - 30" Spacing 11 / 13 Coulters

NOTE: TORQUE ALL TOOLBAR MOUNTING U-BOLTS TO 50 FT / LBS (67.5 N•m).

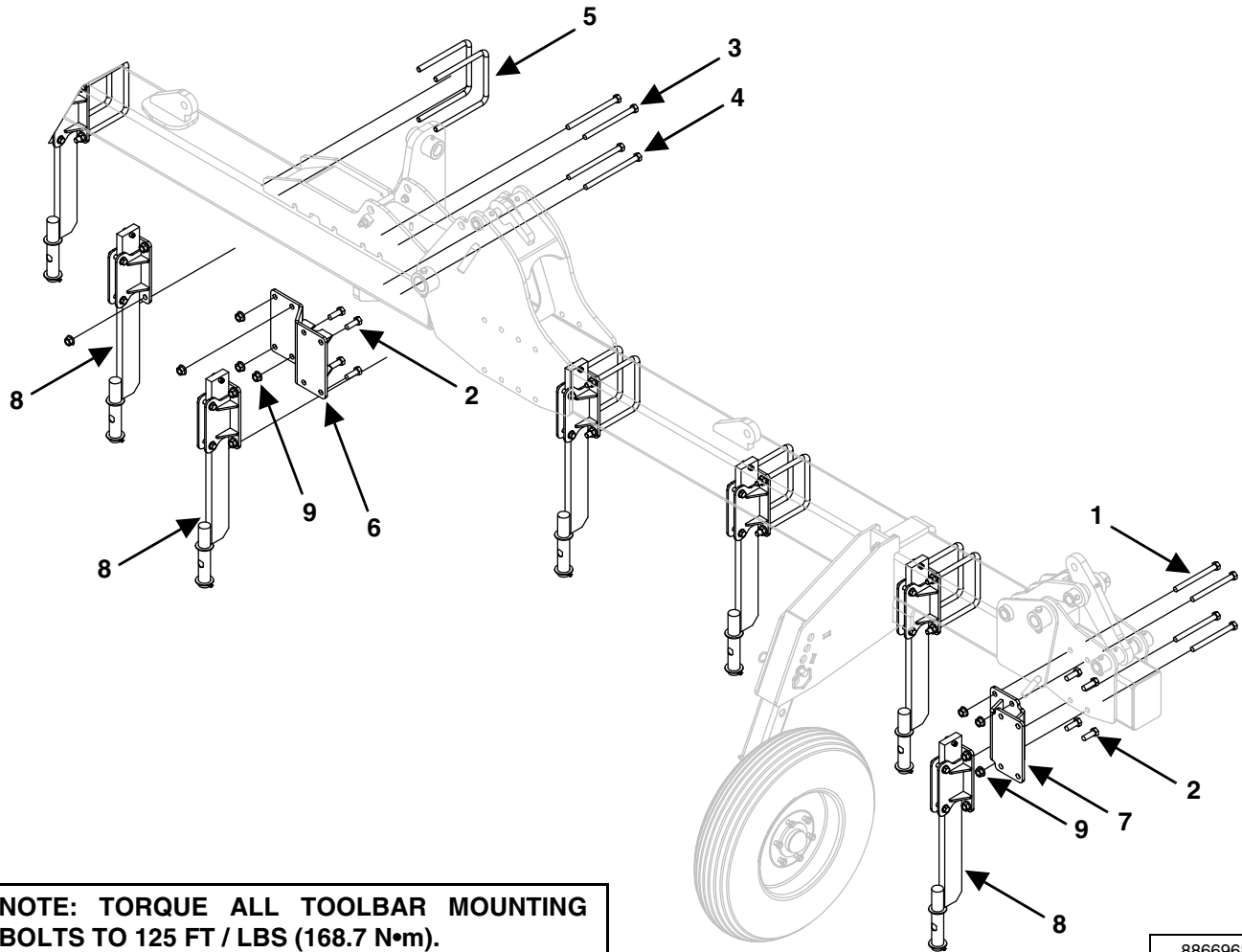

NOTE: TORQUE ALL TOOLBAR MOUNTING BOLTS TO 125 FT / LBS (168.7 N•m).

88669686A1

ITEM	PART NUMBER	DESCRIPTION	QTY
1	00280293	BOLT, 5/8-11 x 7" HEX, GR 5 YZ	8
2	09627896	BOLT 0.62" x 1-3/4" HEX GR 5 PL	16
3	86507001	BOLT, 5/8-11 x 8-1/2" HEX, GR 5 YZ	4
4	86622984	BOLT, HEX, 5/8-11 x 9" GR 5 YZ	4
5	88669054	U-BOLT, 5/8" x 7" x 8-1/2" GR 5 SQ YZ	18
6	88669142	LONG OFFSET COULTER WELDMENT	2
7	88669143	SHORT OFFSET COULTER WELDMENT	2
8	88669448	ASSEMBLY, COULTER TALL STANDARD	13
9	SXNTFTL062118Y	NUT, 5/8-11 FLG, GR 8	16

COULTER BRACKET GROUP (CONT'D)

10 / 16 Row - 30" Spacing 11 / 17 Coulters

NOTE: TORQUE ALL TOOLBAR MOUNTING U-BOLTS TO 50 FT / LBS (67.5 N•m).

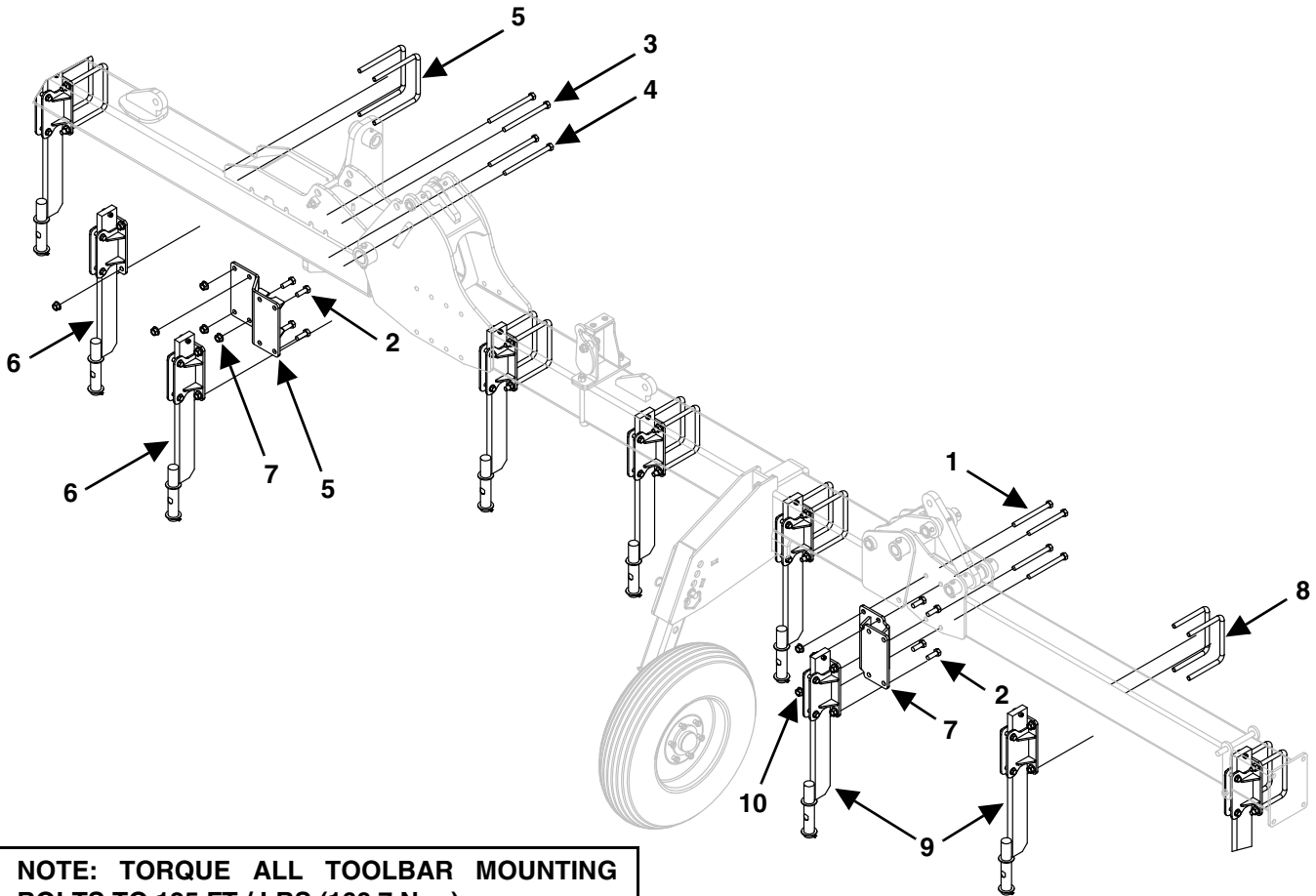

NOTE: TORQUE ALL TOOLBAR MOUNTING BOLTS TO 125 FT / LBS (168.7 N•m).

88669687AI

ITEM	PART NUMBER	DESCRIPTION	QTY
1	00280293	BOLT, 5/8-11 x 7" HEX, GR 5 YZ	8
2	09627896	BOLT 0.62" x 1-3/4" HEX GR 5 PL	16
3	86507001	BOLT, 5/8-11 x 8-1/2" HEX, GR 5 YZ	4
4	86622984	BOLT, HEX, 5/8-11 x 9" GR 5 YZ	4
5	88669054	U-BOLT, 5/8" x 7" x 8-1/2" GR 5 SQ YZ	18
6	88669142	LONG OFFSET COULTER WELDMENT	2
7	88669143	SHORT OFFSET COULTER WELDMENT	2
8	88669377	U-BOLT, 5/8" x 7" x 6-1/2" GR 5 SQ YZ	8
9	88669448	ASSEMBLY, COULTER TALL STANDARD	17
10	SXNTFTL062118Y	NUT, 5/8-11 FLG, GR 8	16

COULTER BRACKET GROUP (CONT'D)

12 / 16 Row - 30" Spacing 13 / 17 Coulters

NOTE: TORQUE ALL TOOLBAR MOUNTING U-BOLTS TO 50 FT / LBS (67.5 N•m).

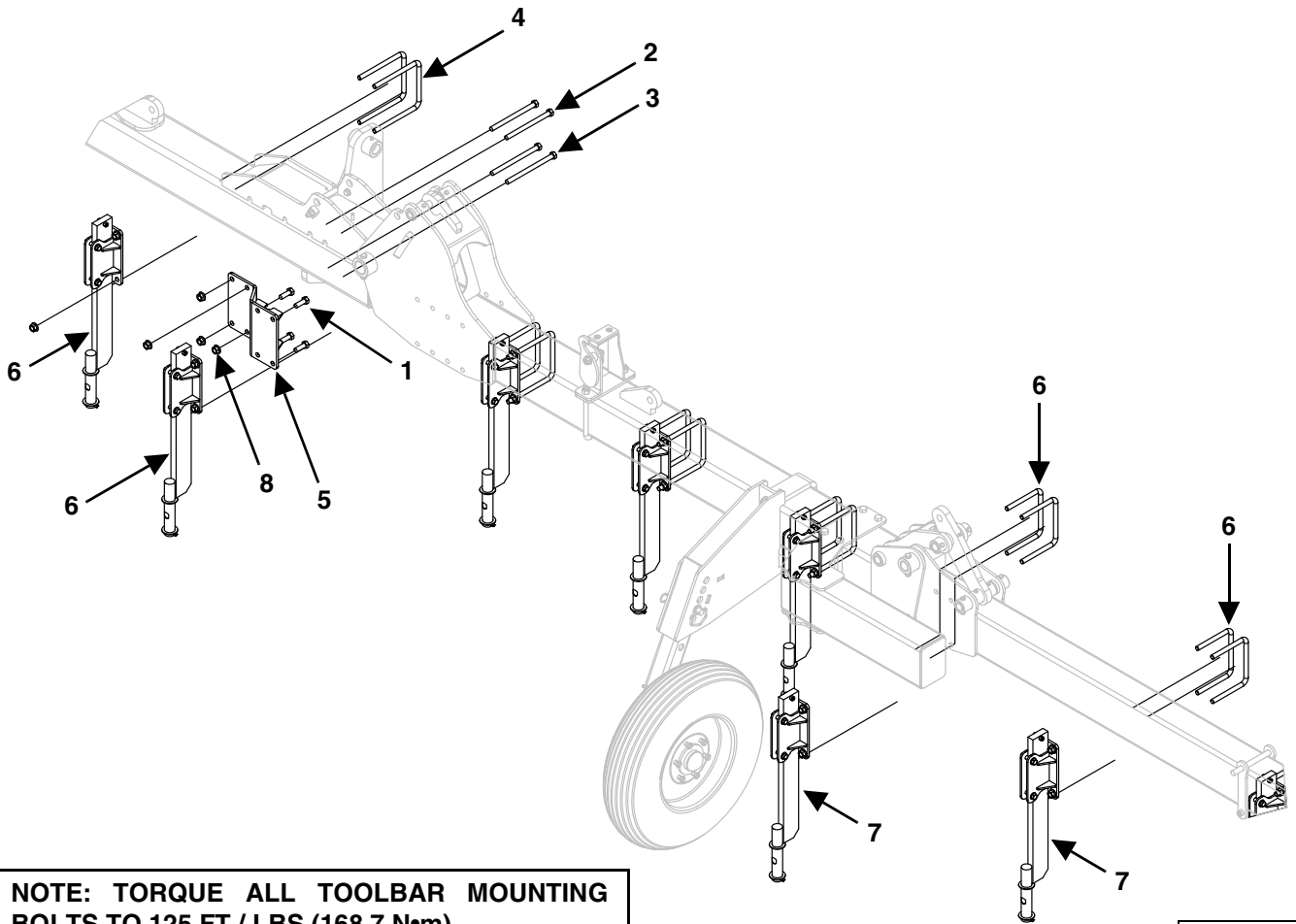

NOTE: TORQUE ALL TOOLBAR MOUNTING BOLTS TO 125 FT / LBS (168.7 N•m).

88669688AI

ITEM	PART NUMBER	DESCRIPTION	QTY
1	09627896	BOLT 0.62" x 1-3/4" HEX GR 5 PL	8
2	86507001	BOLT, 5/8-11 x 8-1/2" HEX, GR 5 YZ	4
3	86622984	BOLT, HEX, 5/8-11 x 9" GR 5 YZ	4
4	88669054	U-BOLT, 5/8" x 7" x 8-1/2" GR 5 SQ YZ	18
5	88669142	LONG OFFSET COULTER WELDMENT	2
6	88669377	U-BOLT, 5/8" x 7" x 6-1/2" GR 5 SQ YZ	12
7	88669448	ASSEMBLY, COULTER TALL STANDARD	17
8	SXNTFTL062118Y	NUT, 5/8-11 FLG, GR 8	8

COULTER BRACKET GROUP (CONT'D)

8 / 12 Row - 38" Spacing 9 / 13 Coulters

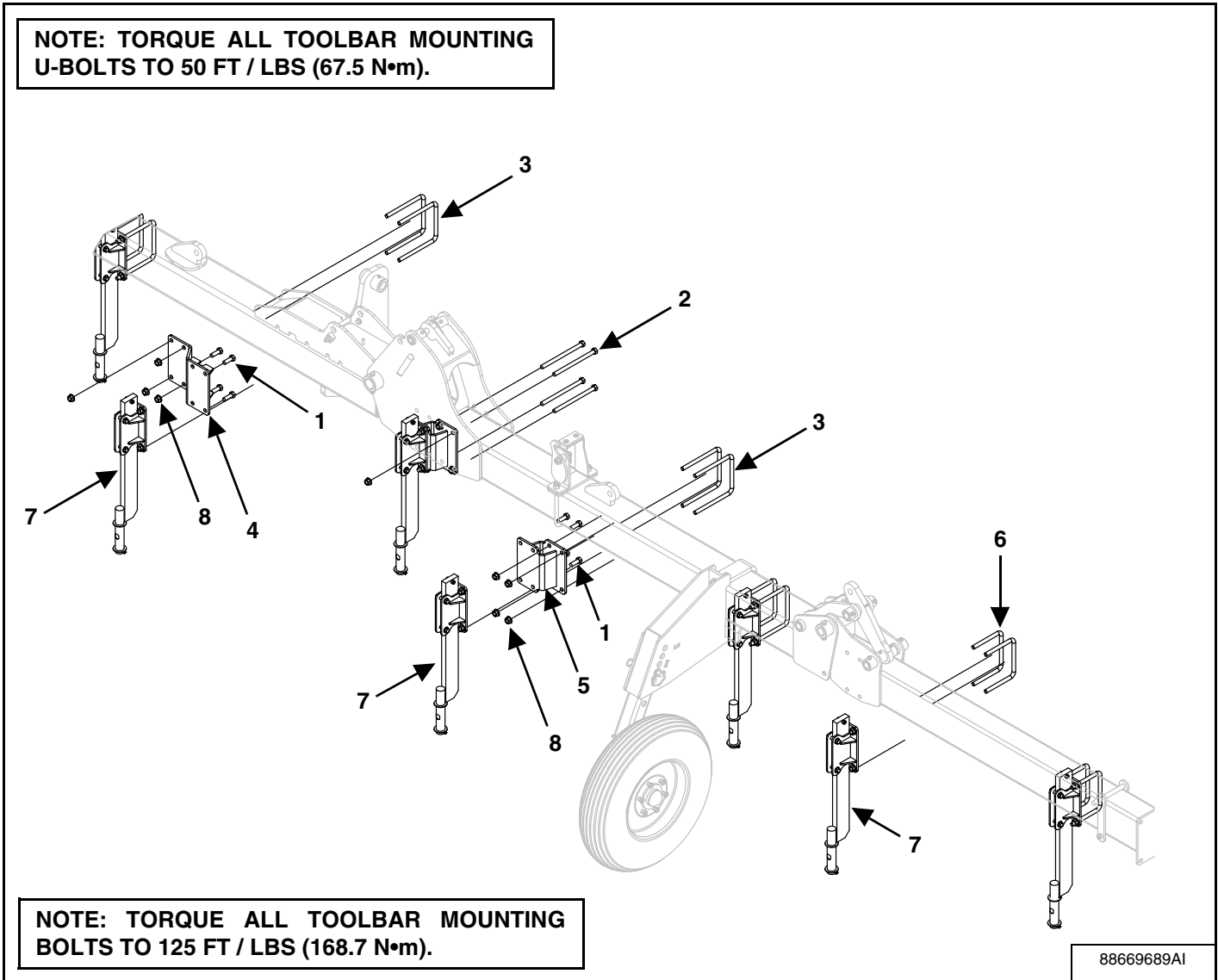

ITEM	PART NUMBER	DESCRIPTION	QTY
1	09627896	BOLT 0.62" x 1-3/4" HEX GR 5 PL	24
2	86509114	BOLT, HEX, 5/8-11 x 9-1/2" HEX, GR 5 YZ	8
3	88669054	U-BOLT, 5/8" x 7" x 8-1/2" GR 5 SQ YZ	14
4	88669142	LONG OFFSET COULTER WELDMENT	2
5	88669143	SHORT OFFSET COULTER WELDMENT	4
6	88669377	U-BOLT, 5/8" x 7" x 6-1/2" GR 5 SQ YZ	8
7	88669448	ASSEMBLY, COULTER TALL STANDARD	13
8	SXNTFTL062118Y	NUT, 5/8-11 FLG, GR 8	24

RIPPLE COULTER W / INJECT GROUP

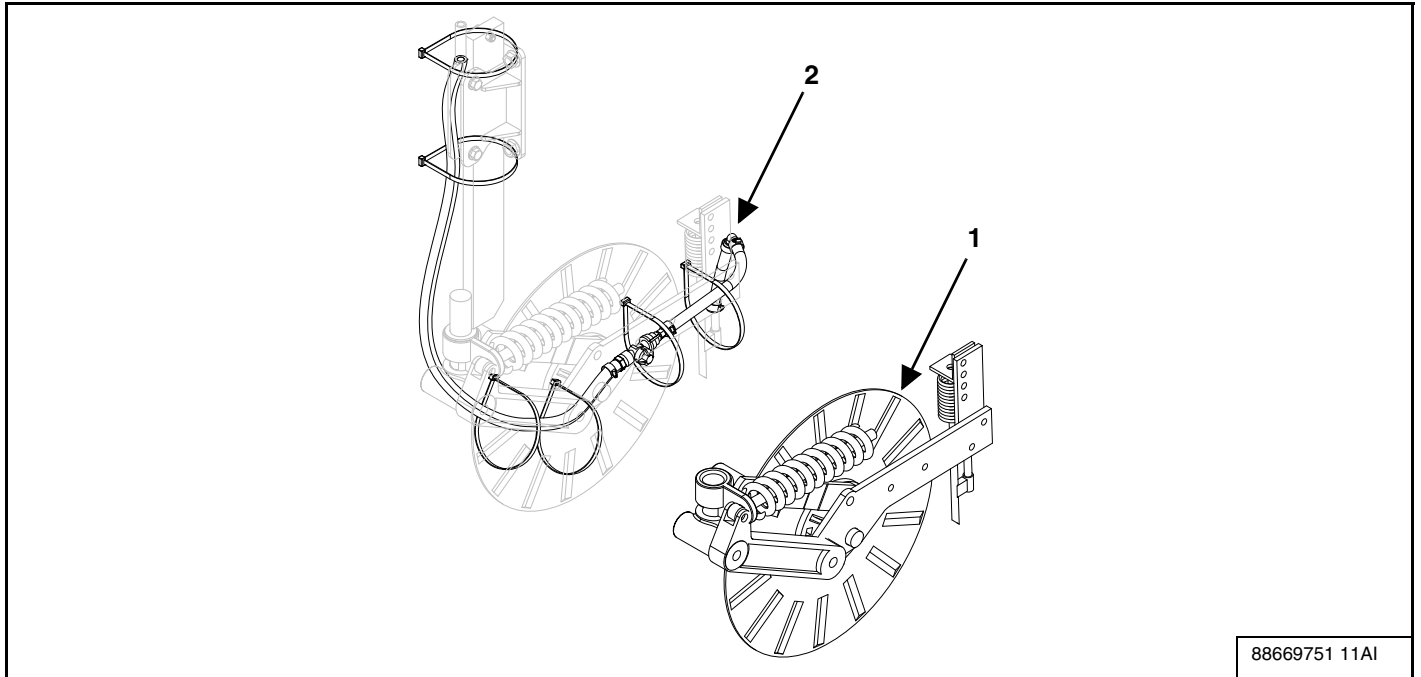

11 Coulter Assembly

ITEM	PART NUMBER	DESCRIPTION	QTY
1	88669187	ASSEMBLY, COLT RIP W/INJC, NO STAND	11
2	88670009	COULTER INJECTOR HOSE, ASSEMBLY	11

13 Coulter Assembly

ITEM	PART NUMBER	DESCRIPTION	QTY
1	88669187	ASSEMBLY, COLT RIP W/INJC, NO STAND	13
2	88670009	COULTER INJECTOR HOSE, ASSEMBLY	13

15 Coulter Assembly

ITEM	PART NUMBER	DESCRIPTION	QTY
1	88669187	ASSEMBLY, COLT RIP W/INJC, NO STAND	15
2	88670009	COULTER INJECTOR HOSE, ASSEMBLY	15

17 Coulter Assembly

ITEM	PART NUMBER	DESCRIPTION	QTY
1	88669187	ASSEMBLY, COLT RIP W/INJC, NO STAND	17
2	88670009	COULTER INJECTOR HOSE, ASSEMBLY	17

19 Coulter Assembly

ITEM	PART NUMBER	DESCRIPTION	QTY
1	88669187	ASSEMBLY, COLT RIP W/INJC, NO STAND	19
2	88670009	COULTER INJECTOR HOSE, ASSEMBLY	19

25 Coulter Assembly

ITEM	PART NUMBER	DESCRIPTION	QTY
1	88669187	ASSEMBLY, COLT RIP W/INJC, NO STAND	25
2	88670009	COULTER INJECTOR HOSE, ASSEMBLY	25

RH 2996 FERT COULTER LIQUID KNIFE

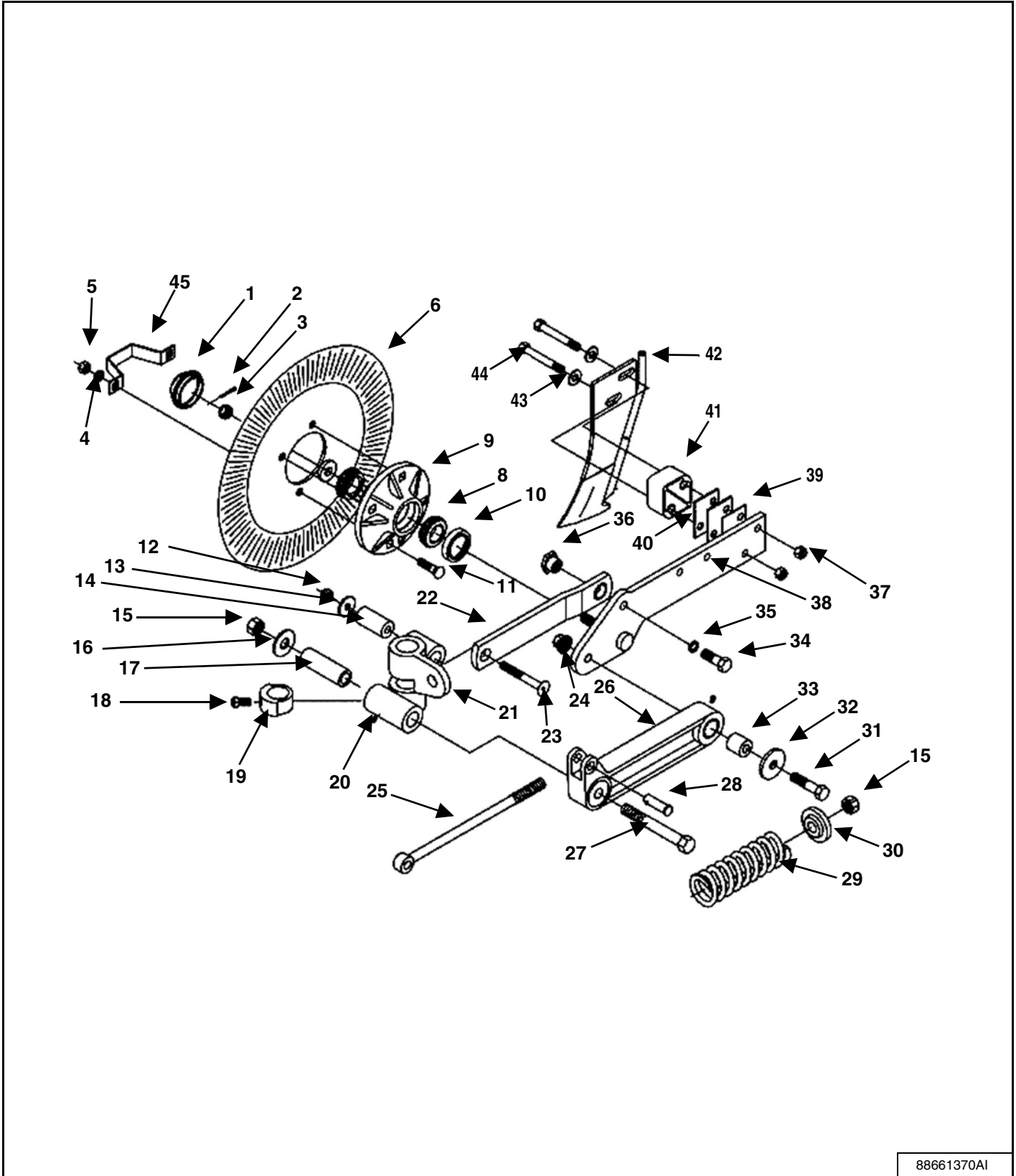

88661370AI

ITEM	PART NUMBER	DESCRIPTION	QTY
1	SX2570-375	HUB CAP	1
2	88664879	COTTER PIN, 1/8" x 1-1/4" BLK	1
3	88664880	SLOTTED NUT, 5/8"-18 HEX BLK	1
4	88664881	LOCKWASHER, 1/2" MED ZP.	4
5	88664882	NUT, 1/2"-13 HEX ZP.	4
6	SX2571-076	RIPPLE BLADE, 20"	1
	88667047	SMOOTH BLADE, 0.157" x 20"	1
7	88664883	FLATWASHER, 1/4" x 5/8" ± 0.010 TH	1
8	SX2550-027	CONE, LM67048	2
9	88664884	HUB PRESSED ASSY	1
	SX2550-029	CUP (PRE-ASSY W/9) LM67010	2
10	88664885	TRIPLE LIP SEAL, NTI #1812-4	1
11	88664886	CARRIAGE BOLT, 1/2"-13 x 1-1/4" GR5 ZP	4
12	88664887	LOCKNUT, 1/2"-13 HEX ZP	1
13	88664888	WASHER, 1/2" ID x 1-1/2" OD x 10 GA MA BU ZP	1
14	88664889	PIVOT SLEEVE	1
15	88664890	LOCKNUT, 3/4"-10 HEX ZP	2
16	SXFW-075-SAE-YZ	FLATWASHER, 3/4" STANDARD ZP	1
17	88664891	PIVOT SLEEVE	1
18	88664892	BOLT, 5/8"-11 x 1" SQ. HCPSS GR 5 ZP	1
19	SX2975-303	LOCKING COLLAR 2975	1
20	88664893	ZERK, 1/4"-28 STRAIGHT SELF-TAP	3
21	88664894	COULTER PIVOT, RH (SHOWN)	1
	88664895	COULTER PIVOT, LH	1
22	88664896	UPPER COULTER ARM ASSY	1
	88664897	BUSHING, 1" ID x 1-1/4" OD x 1/2" BRNZ	1
23	88664898	BOLT, 1/2"-13 x 4" HSFHCS	1
24	88664899	LOCKNUT, 5/8"-11 WHIZ HEXT ZP	1
25	88664900	SPRING ROD, 13-1/2"	1

RH 2996 FERT COULTER LIQUID KNIFE (CONT'D)

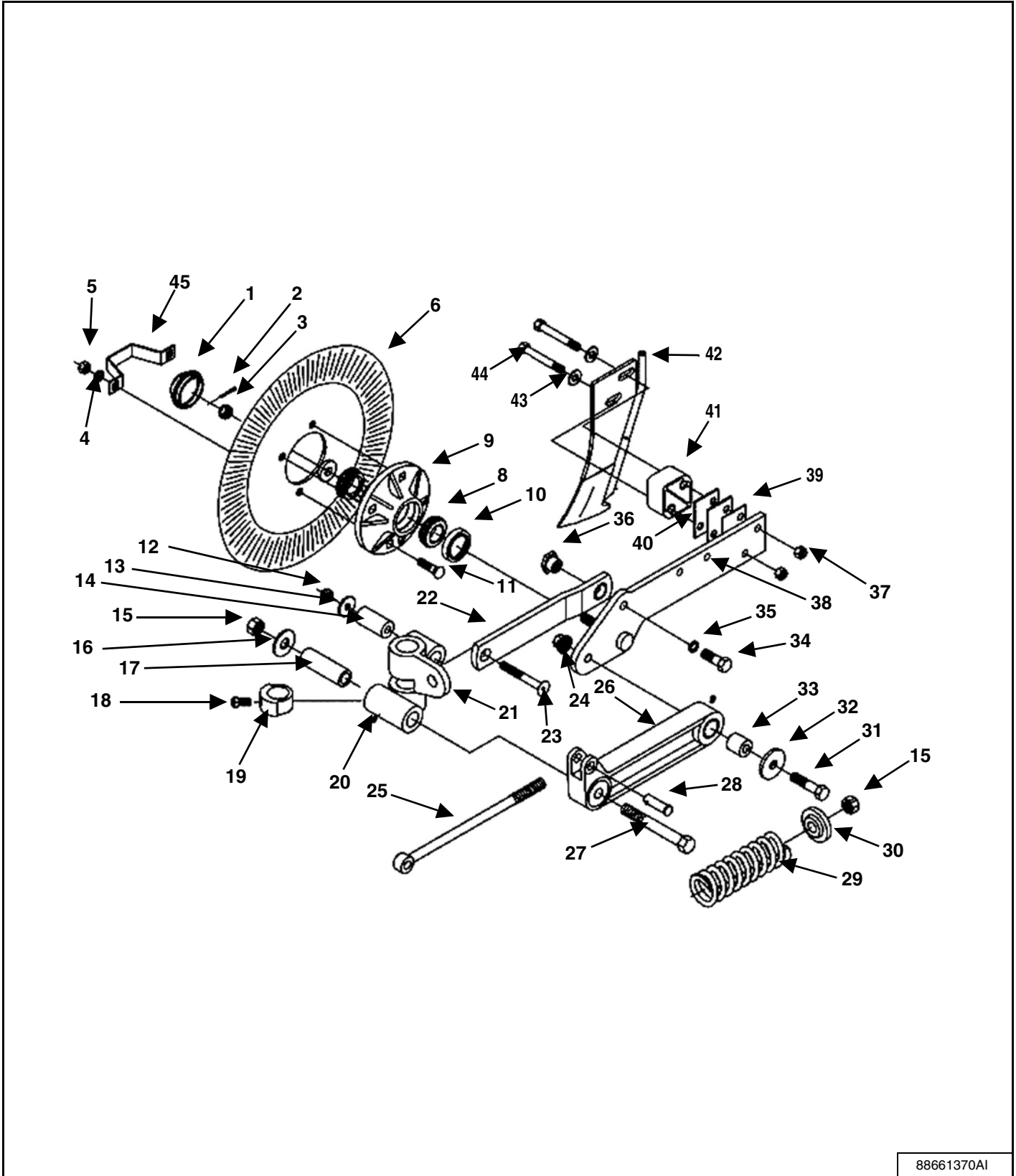

88661370AI

ITEM	PART NUMBER	DESCRIPTION	QTY
26	SX2995-110	LOWER COULTER ARM ASSY	1
	88664901	ARM BUSHING, 2995 BRNZ	1
27	88664902	BOLT, 3/4"-10 x 6" HHCS GR 5 ZP	1
28	88664903	PIN, 5/8" x 1-3/4" SLIC YYD	1
29	SX2550-795	SPRING, 0.562" WIRE x 11" LONG	1
30	88664904	SPRING BUSHING, 2975 PAINTED	1
31	88664905	BOLT, 5/8"-11 x 2-1/2" HHCS GR 5 ZP	1
32	88664906	WASHER, 21/32" ID x 2-1/4" OD x 1/4" MA BU	1
33	88664907	LOWER ARM PIVOT	1
34	88664908	BOLT, 5/8"-18 x 1-1/2" HHCS GR 5 ZP	1
35	88664909	LOCKWASHER, 5/8" MED ZP	1
36	88664910	UPPER ARM PIVOT/WASHER ZP	1
37	88664911	LOCK NUT, 1/2"-13 HEX NIF- ZP	2
38	SX2996-205	RH 2996 KNIFE ARM / SPINDLE WA	1
	88664912	LH 2996 KNIFE ARM / SPINDLE WA	1
39	88664913	KNIFE SHIM 16 GA ZP	1
40	88664914	KNIFE SHIM, 1/8" ZP	2
41	SX2995-309	SPACER BLOCK, 1.531"	1
42	SX2996-200	20" LIQUID FERTILIZER KNIFE WA	1
43	88664915	FLAT WASHER, 1/2" HARDENED PC	2
44	88664916	BOLT, 1/2"-13 x 3-1/2" HHCS GR 8 ZDP	2
	88664917	CRITICAL ADJUSTMENT DECAL	1
	88664918	ROLL PIN FOR SHANK	1
	88664919	COTTER PIN FOR SHANK	1
45	88664920	HUB CAP RETAINER	1

COULTER W/INJECTOR ASSEMBLY

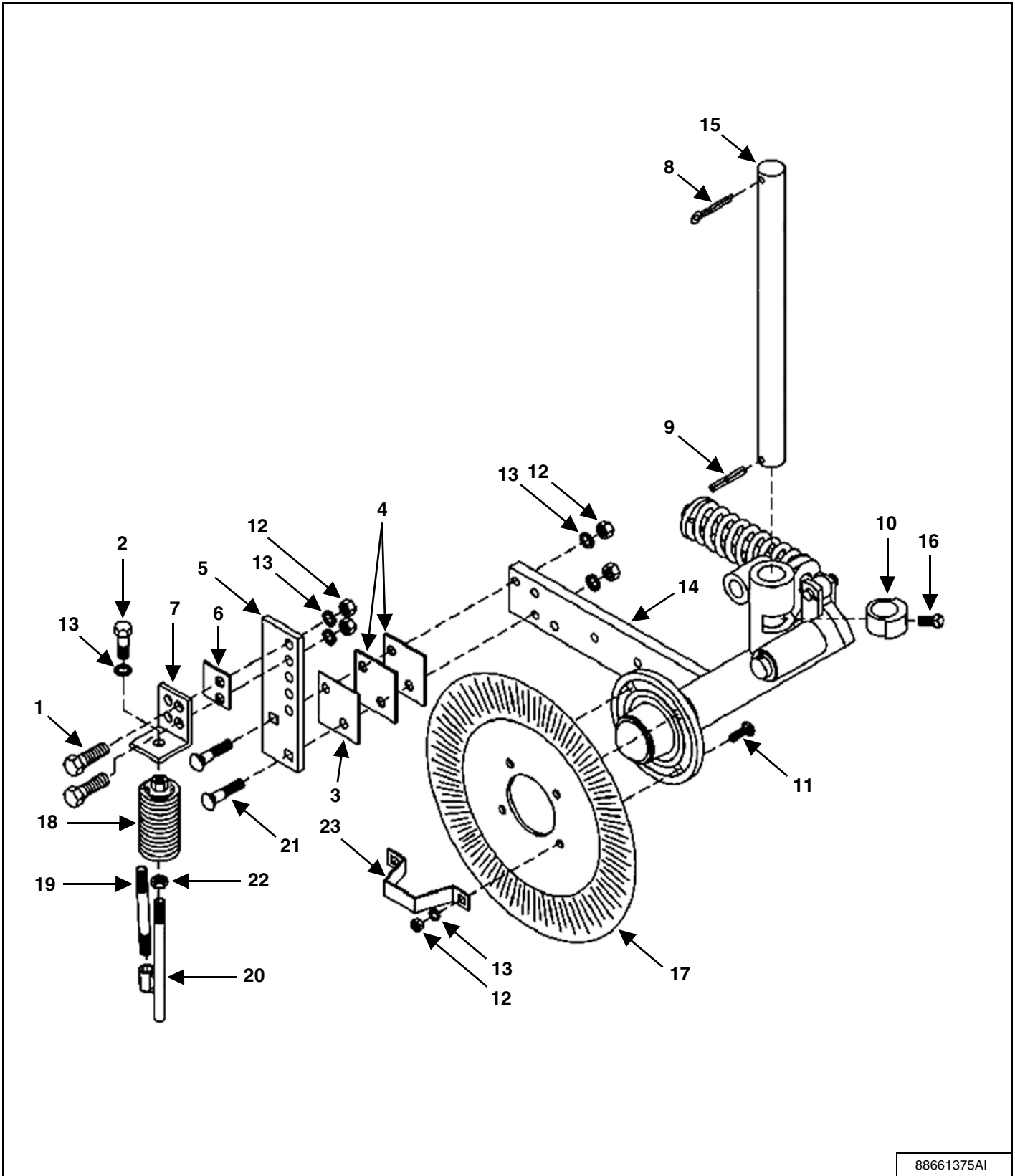

88661375AI

ITEM	PART NUMBER	DESCRIPTION	QTY
1	00012008	BOLT, 1/2"-13 x 1-1/2" HHCS GR 5 ZP	2
2	00012071	BOLT, 1/2"-13 x 1" HHCS GR 5 ZP	2
3	88664913	KNIFE SHIM, 16 GA. ZP	1
4	88664914	KNIFE SHIM, 1/8" ZP	2
5	88664922	INJECTOR ADJUSTMENT PLATE	2
6	SX2995-320	INJECTOR SPACER	1
7	SX2995-301	INJECTOR MOUNT PLATE	1
8	88664919	COTTER PIN, 5/16" x 2-1/2" ZP	1
9	88664918	ROLL PIN, 3/8" x 2-1/2" ZP	1
10	88664892	BOLT, 5/8"-11 x 1" SQ HCPSS GR 5 Z	1
11	88664886	CARRIAGE BOLT, 1/2"-13 x 1-1/4" GR 5	4
12	88664882	NUT, 1/2"-13 HEX ZP	8
13	88664881	LOCKWASHER, 1/2" MED ZP	9
14	88664923	GEN III CLTR W/KNIFE ARM ASSY	1
15	88661373	SHANK, 1-1/2" x 27-1/8"	1
16	SX2975-303	LOCKING COLLAR	1
17	88661371	RIPPLE BLADE, 0.157 x 20"	1
	88667047	SMOOTH BLADE, 0.157" x 20"	1
18	SX2995-131	SPRING INJECTOR ASSEMBLY	1
19	88664924	3" NIPPLE, 1/4" NPT SS	1
20	88664925	INJECTOR ROD, 1/2"-13 W A	1
21	88664926	CARRIAGE BOLT, 1/2"-13 x 2" GR 5 ZP	2
22	88664927	JAM NUT, 1/2"-13 HEX ZP	1
23	88664920	HUB CAP RETAINER	1

COULTER ARM ASSEMBLY

RH W / Injector

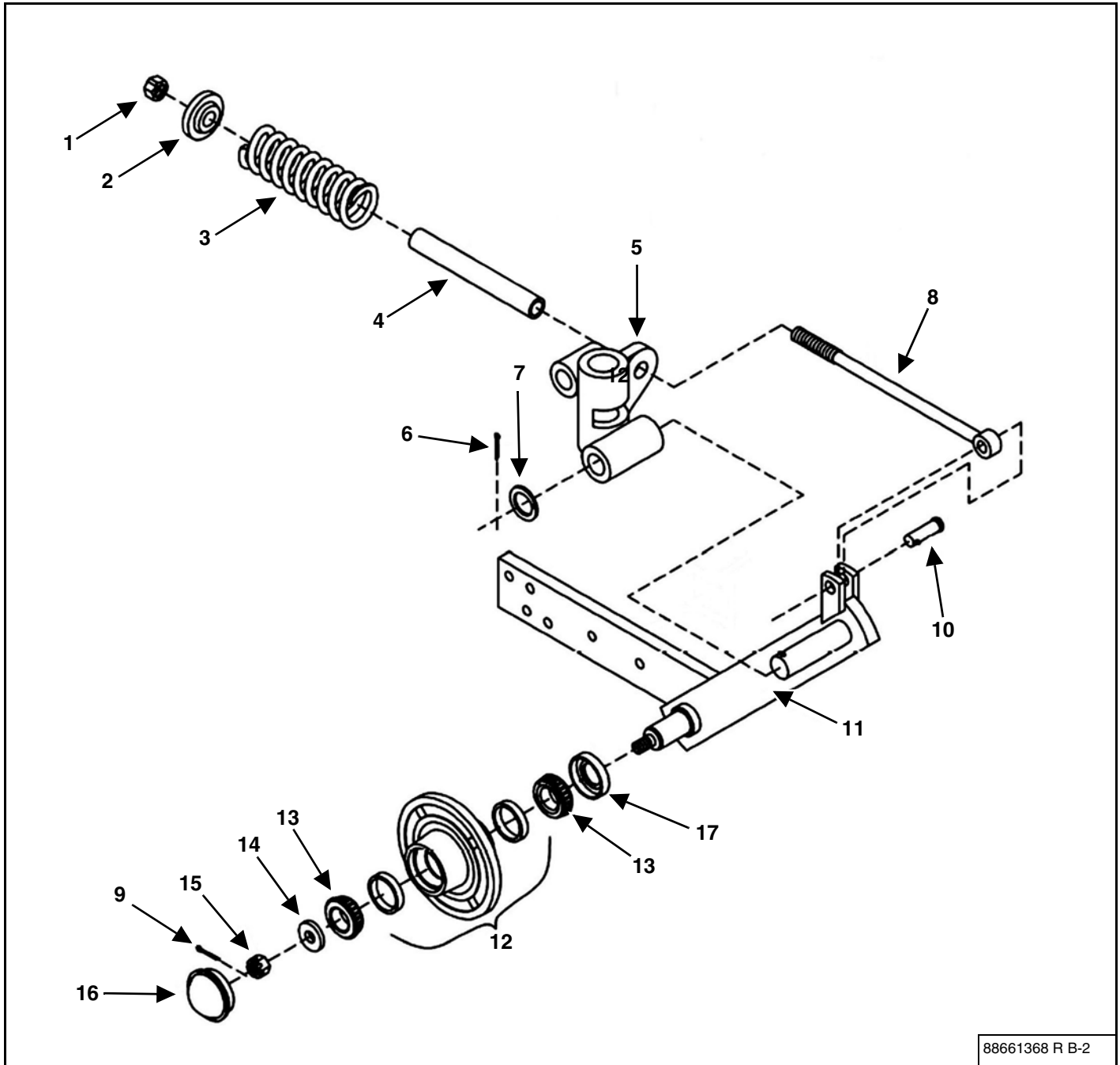

ITEM	PART NUMBER	DESCRIPTION	QTY
1	88664927	1/2"-13 JAM HEX NUT ZP	1
2	88664904	2975 SPRING BUSHING PAINTED	1
3	SX2550-795	SPRING, 0.562" WIRE x 11" LONG	1
4	88667464	10" POLY HELPER SPRING	1
5	88664929	COULTER PIVOT, RH (SHOWN)	1
	88664895	COULTER PIVOT, LH	1
6	812435	1/4" x 1 3/4" COTTER PIN ZYD	1
7	88667463	1 17/64" ID x 1 7/8" OD x 14GA MB	1
8	88664900	SPRING ROD, 13-1/2"	1
9	88664879	1/8" x 1 1/4" COTTER PIN BLACK	1
10	88664903	5/8" x 1 3/4" SLIC PIN ZYD	1
11	88664932	GEN III W / KNIFE ARM WA RH (SHOWN)	1
12	88664884	HUB PRESSED ASSEMBLY	1
	88664893	1/4"-28 ZERK STRAIGHT SELF-TAP	1
	SX2550-029	CUP, LM67010	2
	88664934	PLOW COULTER HUB CASTING	1
13	SX2550-027	CONE, LM67048	2
14	88664883	5/8" FLATWASHER, 1/4" +/- 0.010 THICK	1
15	88664880	5/8"-18 SLOTTED HEX NUT, BLACK	1
16	SX2570-375	HUB CAP, WILTON #909902	1
17	88664885	TRIPLE LIP SEAL, NTI #1812-4	1

RIPPLE COULTER W / KNIFE GROUP

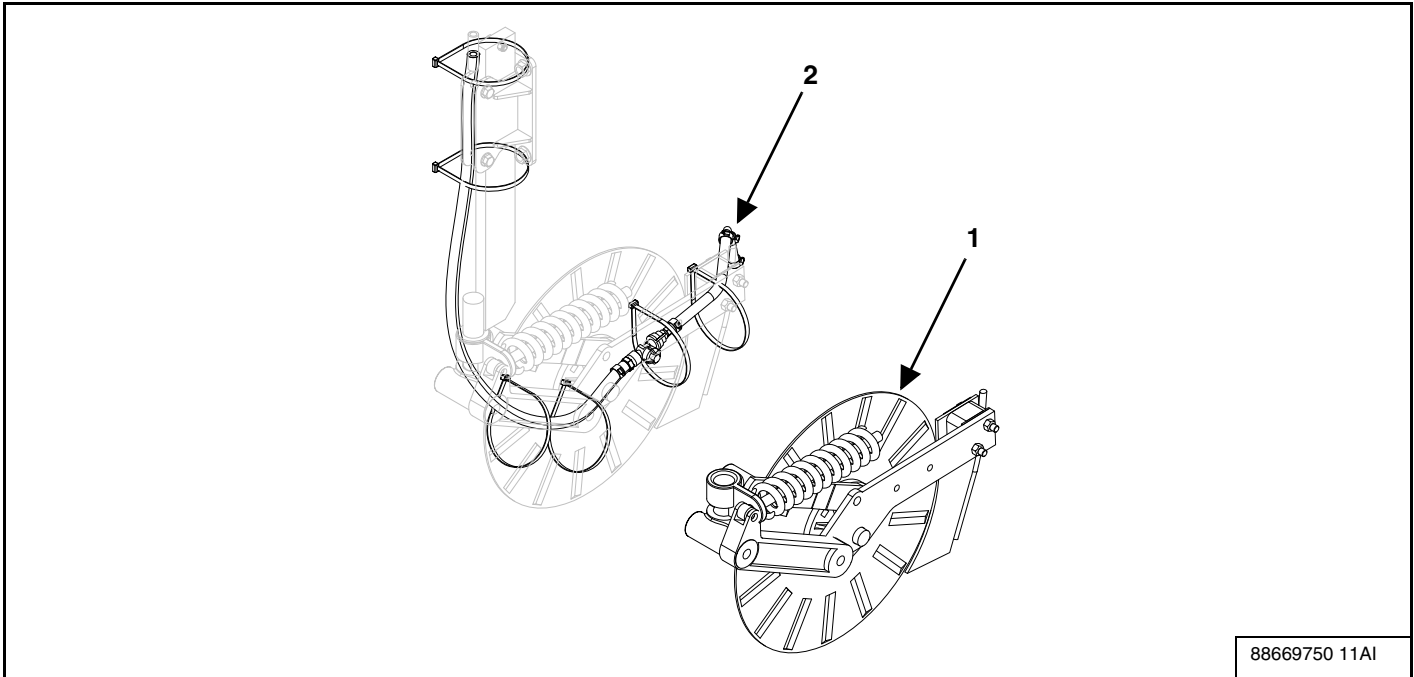

11 Coulter Assembly

ITEM	PART NUMBER	DESCRIPTION	QTY
1	88669188	COLT RIPPLE, W/KNIFE, N/STND	11
2	88670008	COULTER KNIFE HOSE, ASSEMBLY	11

13 Coulter Assembly

ITEM	PART NUMBER	DESCRIPTION	QTY
1	88669188	COLT RIPPLE, W/KNIFE, N/STND	13
2	88670008	COULTER KNIFE HOSE, ASSEMBLY	13

15 Coulter Assembly

ITEM	PART NUMBER	DESCRIPTION	QTY
1	88669188	COLT RIPPLE, W/KNIFE, N/STND	15
2	88670008	COULTER KNIFE HOSE, ASSEMBLY	15

17 Coulter Assembly

ITEM	PART NUMBER	DESCRIPTION	QTY
1	88669188	COLT RIPPLE, W/KNIFE, N/STND	17
2	88670008	COULTER KNIFE HOSE, ASSEMBLY	17

19 Coulter Assembly

ITEM	PART NUMBER	DESCRIPTION	QTY
1	88669188	COLT RIPPLE, W/KNIFE, N/STND	19
2	88670008	COULTER KNIFE HOSE, ASSEMBLY	19

25 Coulter Assembly

ITEM	PART NUMBER	DESCRIPTION	QTY
1	88669188	COLT RIPPLE, W/KNIFE, N/STND	25
2	88670008	COULTER KNIFE HOSE, ASSEMBLY	25

TIRE / WHEEL SINGLE 320 / 90 R50

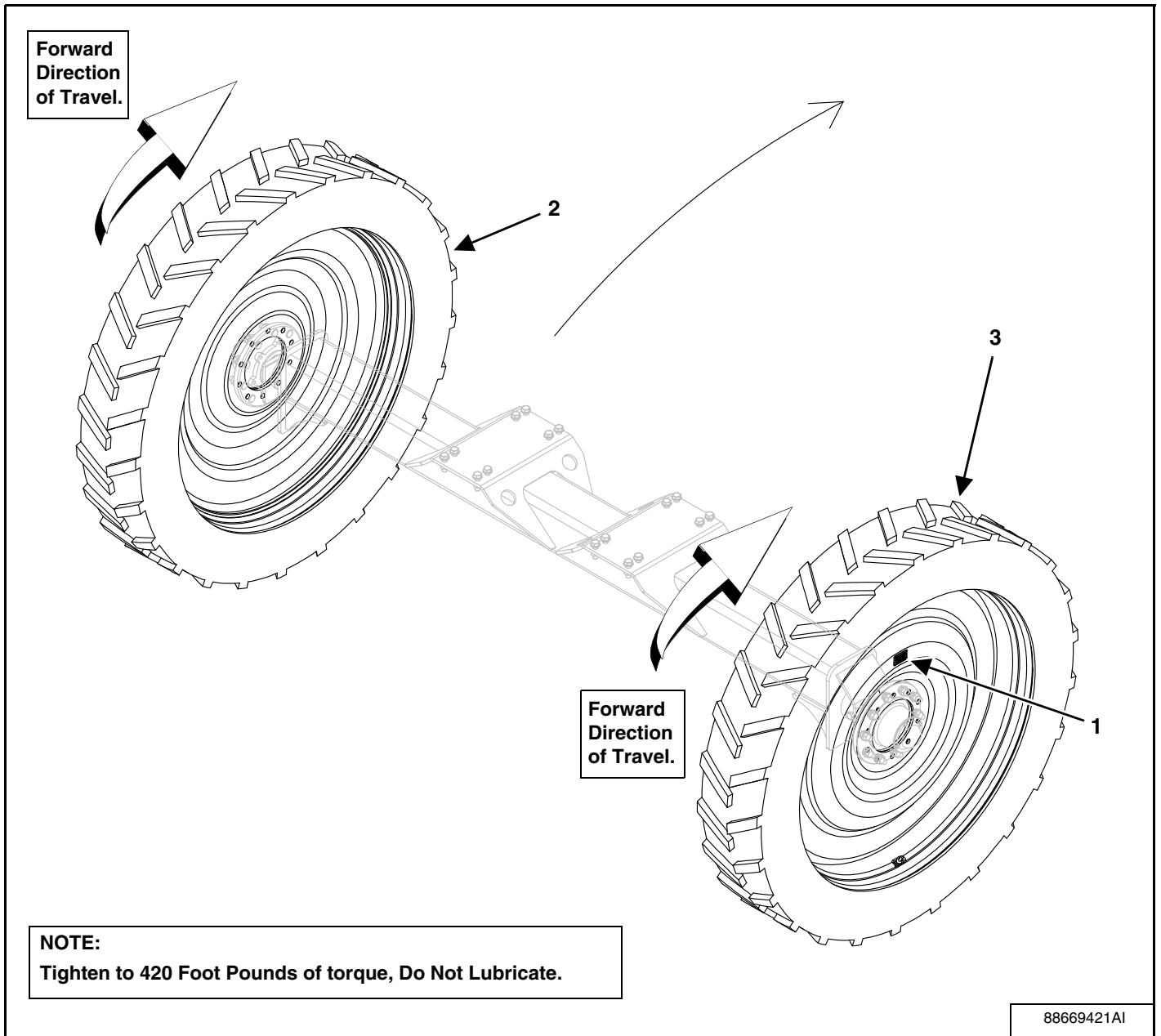

ITEM	PART NUMBER	DESCRIPTION	QTY
1	88661041	DECAL, TORQUE LUGS	2
2	88670291	TIRE ASSEMBLY, 320 / 90 R50 LH CREAM	1
3	88670292	TIRE ASSEMBLY, 320 / 90 R50 RH CREAM	1

TIRE / WHEEL SINGLE 380 / 90 R46

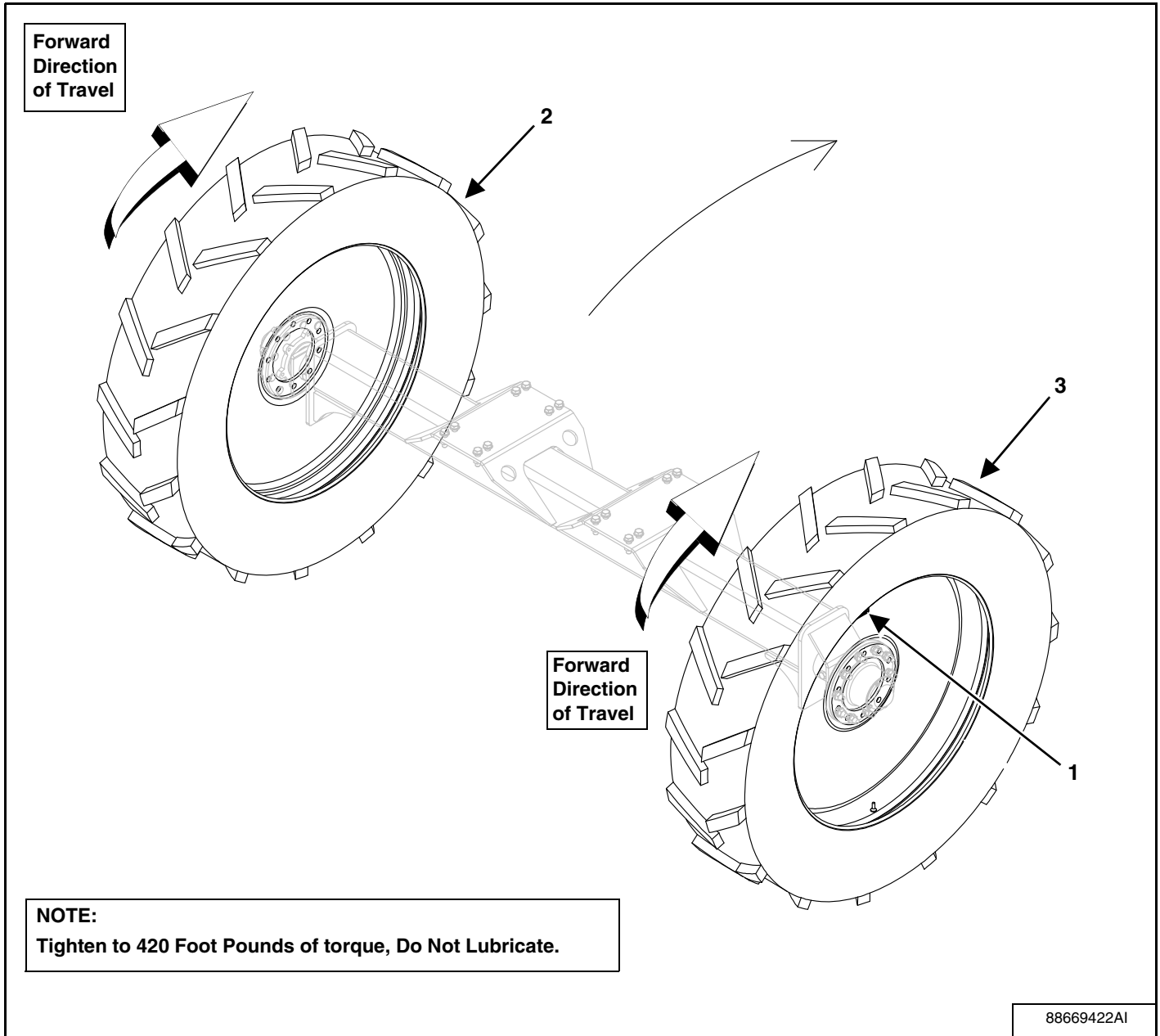

ITEM	PART NUMBER	DESCRIPTION	QTY
1	88661041	DECAL, TORQUE LUGS	2
2	SX018238C	TIRE ASSEMBLY, 480 / 90 R46 LH CREAM	1
3	SX018239C	TIRE ASSEMBLY, 480 / 90 R46 RH CREAM	1

TIRE / WHEEL STRADDLE DUAL, 20 IN SPACING

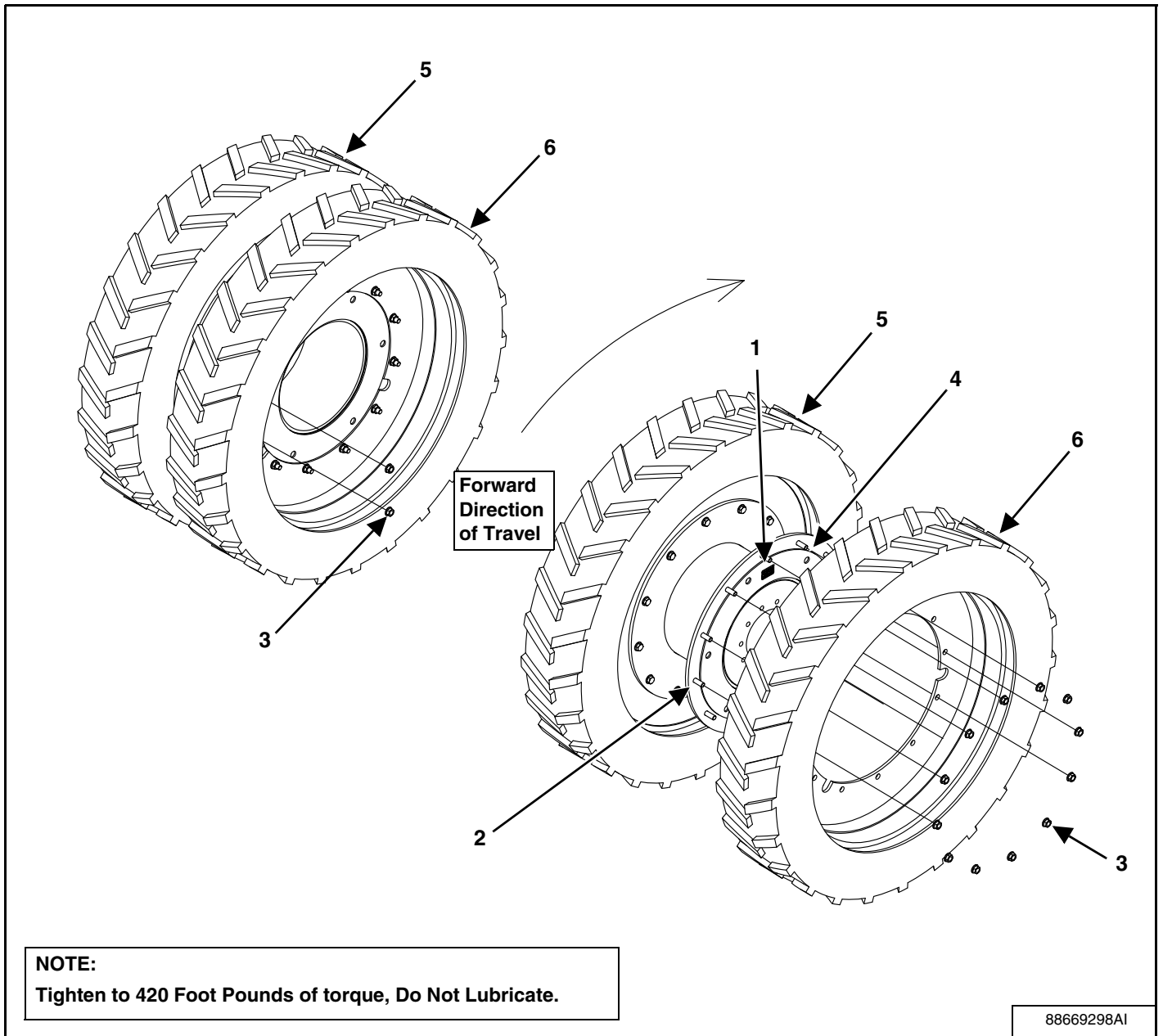

ITEM	PART NUMBER	DESCRIPTION	QTY
1	88661041	DECAL, TORQUE LUGS	2
2	88663734	CSFL G8 P 3/4" x 2.-1/2" NF YZ	48
3	88663735	NUT - FLG TP LCK 3/4"-16 GR 8 YZ	48
4	88669291	HUB SPACER WELDMENT, 20" 46" WHL C	2
5	88669429	TIRE ASSEMBLY, 320/90R46 LHO RHI	2
6	88669430	TIRE ASSEMBLY, 320/90R46 LHI RHO	2

TIRE / WHEEL STRADDLE DUAL, 22 IN SPACING

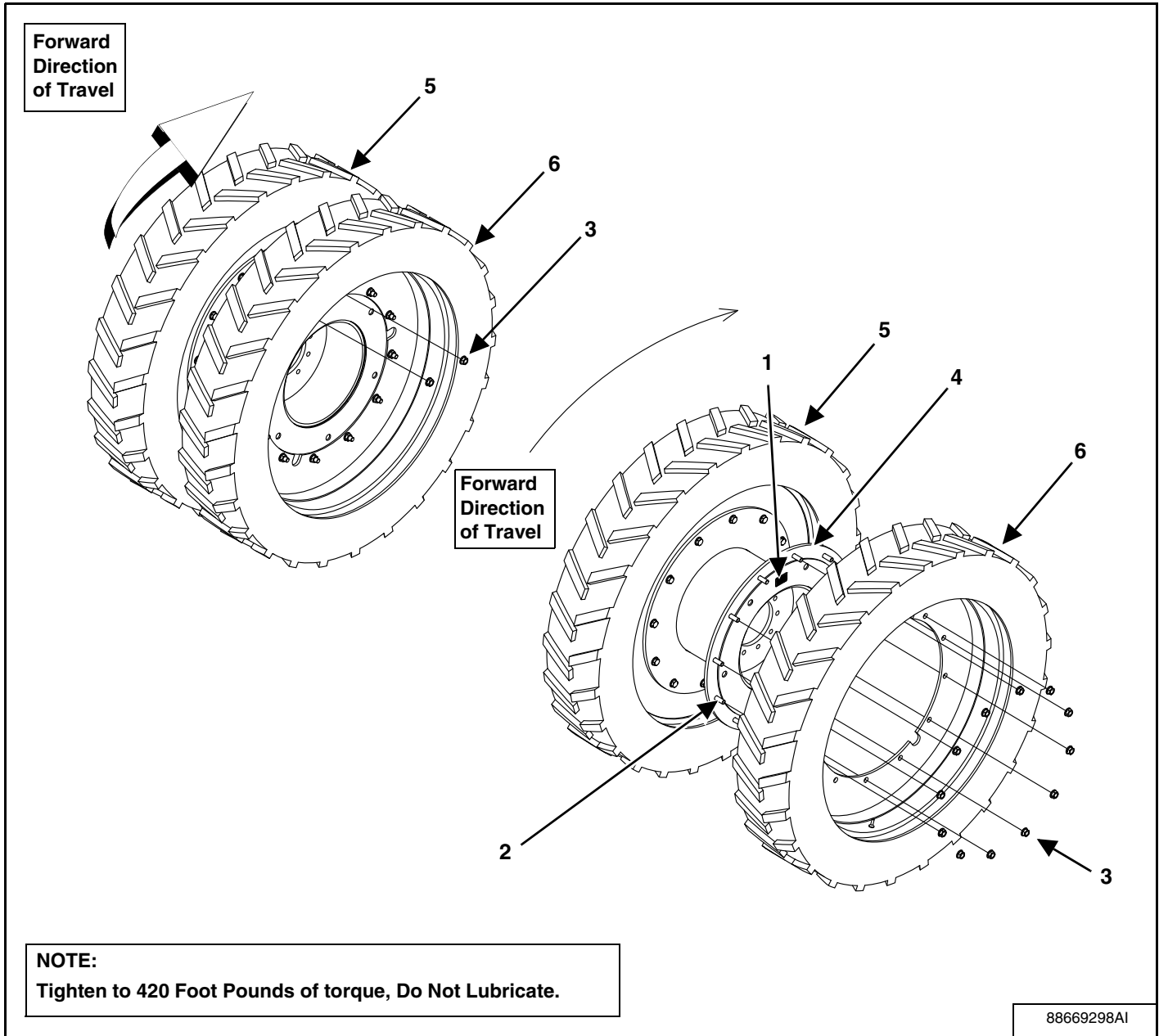

ITEM	PART NUMBER	DESCRIPTION	QTY
1	88661041	DECAL, TORQUE LUGS	2
2	88663734	CSFL G8 P 3/4" x 2.-1/2" NF YZ	48
3	88663735	NUT - FLG TP LCK 3/4"-16 GR 8 YZ	48
4	88669297	HUB SPACER WELDMENT, 22" 46" WHL C	2
5	88669429	TIRE ASSEMBLY, 320/90R46 LHO RHI	2
6	88669430	TIRE ASSEMBLY, 320/90R46 LHI RHO	2

TIRE / WHEEL STRADDLE DUAL, 30 IN SPACING

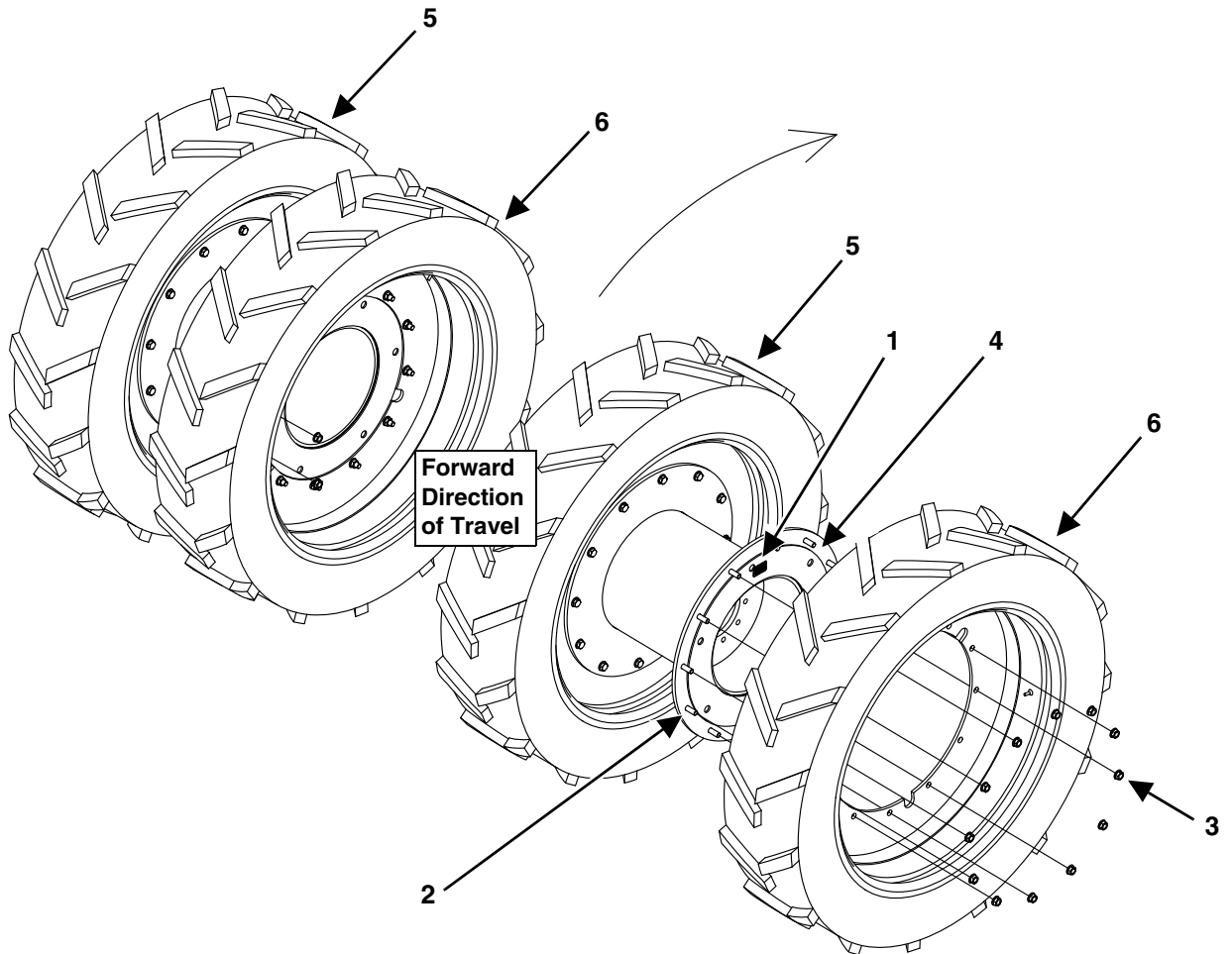

NOTE:
Tighten to 420 Foot Pounds of torque, Do Not Lubricate.

88669298AI

ITEM	PART NUMBER	DESCRIPTION	QTY
1	88661041	DECAL, TORQUE LUGS	2
2	88663734	CSFL G8 P 3/4" x 2.-1/2" NF YZ	48
3	88663735	NUT - FLG TP LCK 3/4"-16 GR 8 YZ	48
4	88669294	HUB SPACER WELDMENT, 30" 46" WHL C	2
5	88669431	TIRE ASSEMBLY, 380/90R46 LHO RHI	2
6	88669432	TIRE ASSEMBLY, 380/90R46 LHI RHO	2

TIRE / WHEEL STRADDLE DUAL, 38 IN SP

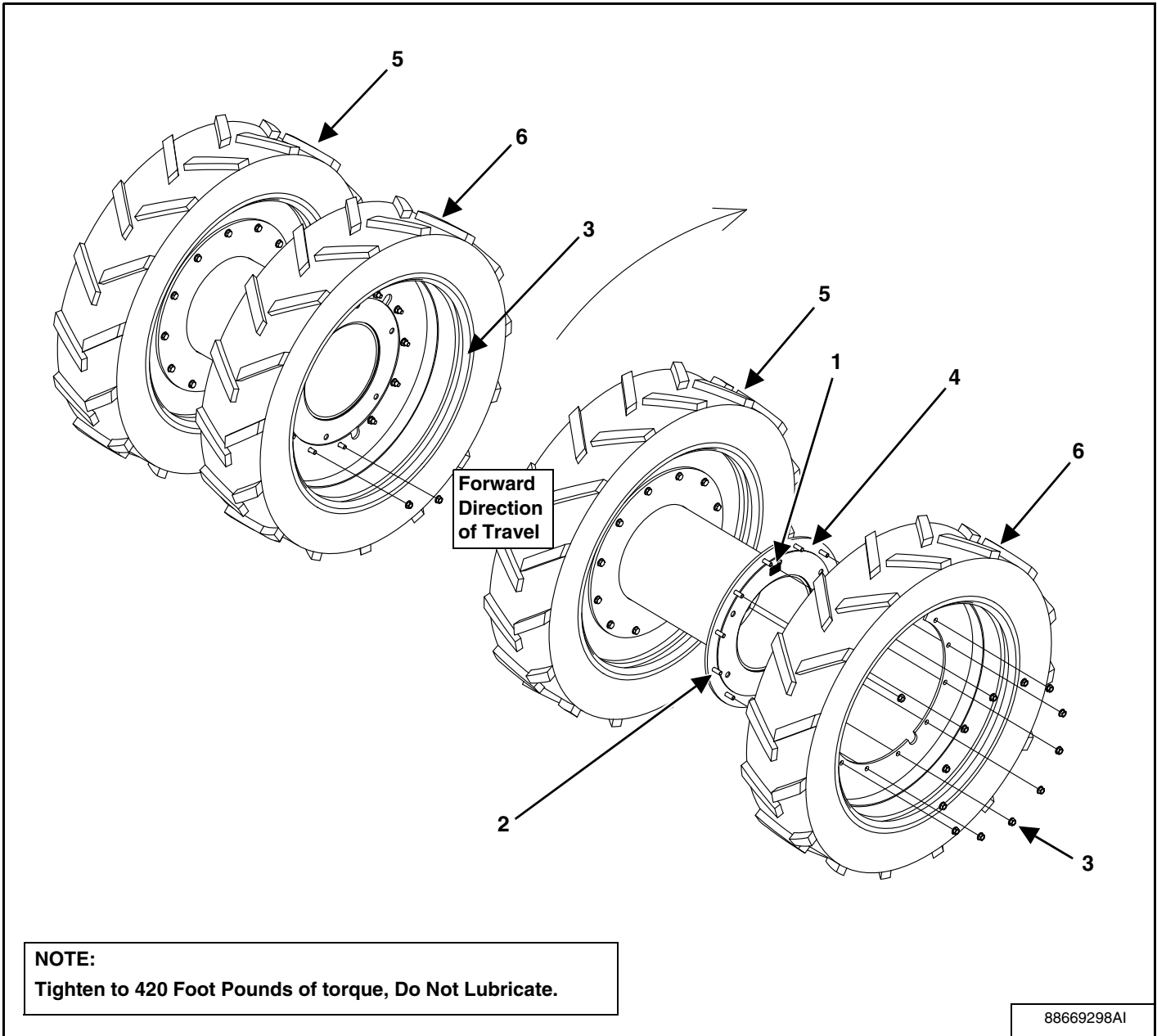

ITEM	PART NUMBER	DESCRIPTION	QTY
1	88661041	DECAL, TORQUE LUGS	2
2	88663734	CSFL G8 P 3/4" x 2.-1/2" NF YZ	48
3	88663735	NUT - FLG TP LCK 3/4"-16 GR 8 YZ	48
4	88669341	HUB SPACER WELDMENT, 38" 46" WHL C	2
5	88669431	TIRE ASSEMBLY, 380/90R46 LHO RHI	2
6	88669432	TIRE ASSEMBLY, 380/90R46 LHI RHO	2

MARKING GROUP ASSEMBLY

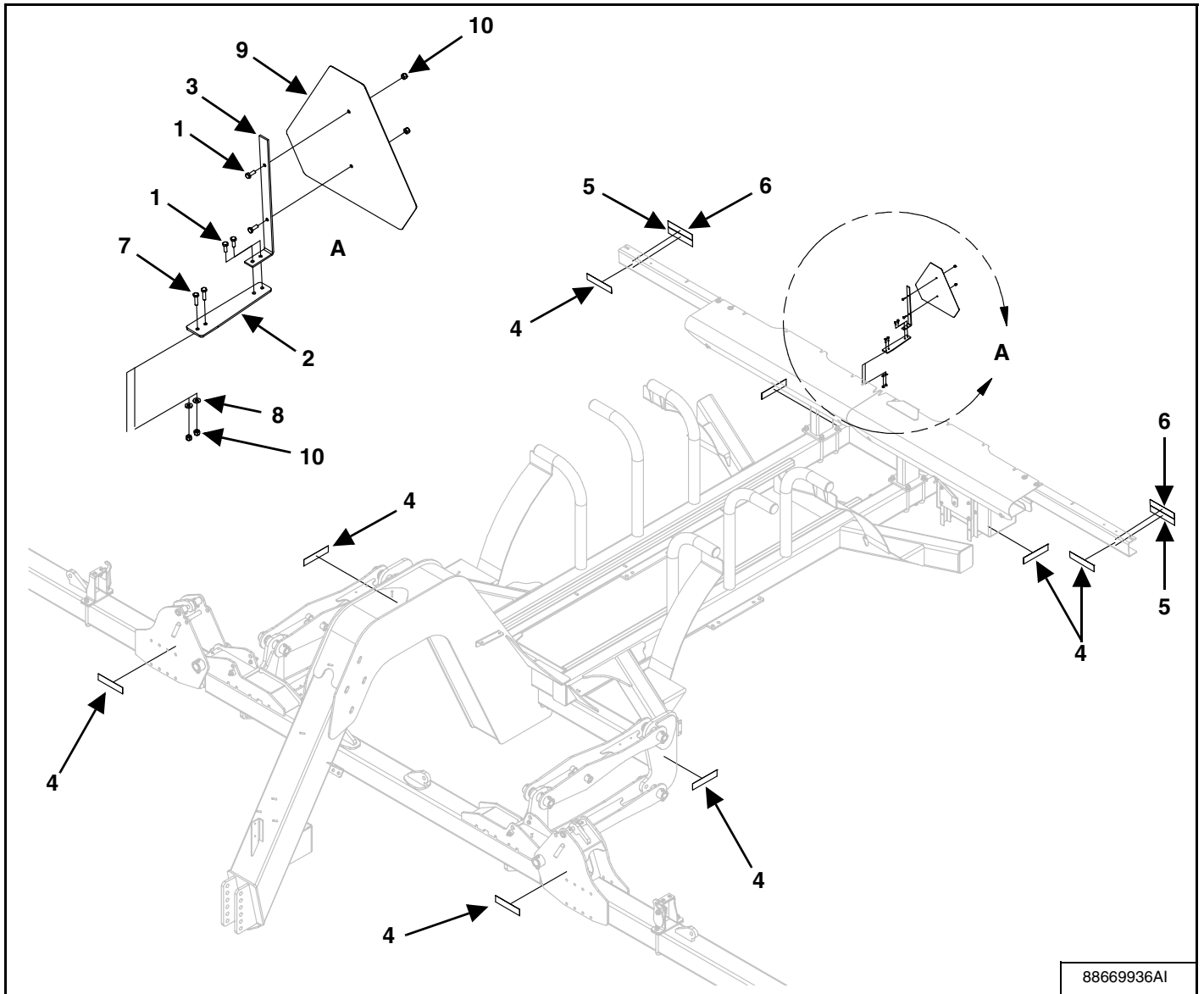

88669936A1

ITEM	PART NUMBER	DESCRIPTION	QTY
1	09707580	BOLT, 1/4" x 3/4" HEX GR 5 PL	4
2	88664979	BRACKET SMV	1
3	SX013588	MNT, SMV	1
4	SX17-5910	DECAL, REFLECT AMBER, 2" x 9"	8
5	SX17-5915	DECAL, REFLECT RED, 2" x 9"	2
6	SX17-5920	DECAL, DAY ORANGE, 2" x 9"	2
7	SXBH0251005YZ	BOLT, 1/4" x 1" GR 5	2
8	SXFW-025-YZ	FLATWASHER, 1/4" ZINC PLATED	2
9	SXJD5403	SIGN, SMV	1
10	SXLN-025-NIYZ	LOCKNUT, 1/4" NYLON INSERT	4

LIGHTING MARKING GROUP

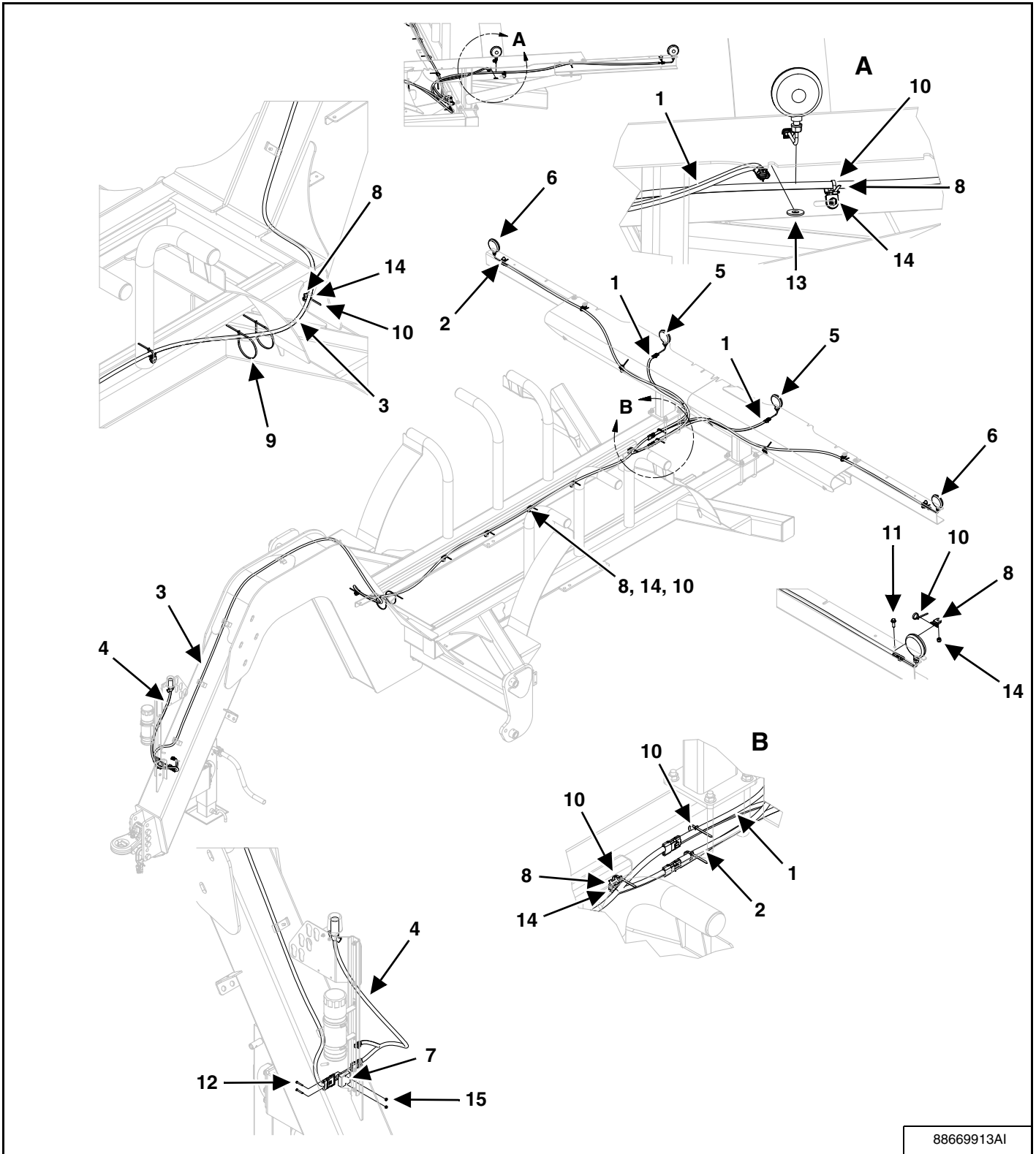

ITEM	PART NUMBER	DESCRIPTION	QTY
1	88665110	RED LIGHT HARNESS	1
2	88665111	AMBER LIGHT HARNESS	1
3	88669929	FRONT TO REAR HARNESS	1
4	88669930	TRACTOR / IMPLEMENT HARNESS	1
5	SX004560	RED TURN / TAIL LAMP	2
6	SX004561	RED TURN / TAIL LAMP	2
7	SX006978	TURN SIGNAL MODULE, (PWI)	1
8	SX21294	HEAVY DUTY CABLE TIE MOUNT	12
9	SX3NS12	BLACK STRAP, 11-1/4" 21	2
10	SX3NS8	BLACK STRAP, 7-1/4"	16
11	SXBHF0381255YZ	BOLT, 3/8" x 1-1/4" HEX FLANGE, GR 5 YZ	3
12	SXBM-10-24-125	BOLT, 10-24 x 1-1/4" MACH.	2
13	SXFW-050YZ	FLATWASHER, 1/2" YZ	2
14	SXLN-038-NIYZ	LOCKNUT, 3/8" NYLON INSERT YZ	9
15	SXLN-10-24-NI	LOCKNUT, 10/24 NYLON INSERT	2

ITEM	PART NUMBER	DESCRIPTION	QTY
1	00087399	CT PN P 0.18 x 1-3/4" 86505604	8
2	00088444	CSHH, 0.38" x 2-3/4" 86505344 GR 5 P	4
3	86513097	HYDRAULIC FITTING, 08 MJIC x 08 MJIC	2
4	86513098	HYDRAULIC FITTING, 10 MJIC x 10 MJIC	2
5	88663859	CNCTR - HYD QUICK DISCONNECT	2
6	88669217	HYDRAULIC CYLINDER, 3 x 14 3000 PSI	2
7	88669444	HYDRAULIC CYLINDER, 4 x 24 3000 PSI	2
8	88669896	SHORT HOSE HOLDER BAR	4
9	88669937	EDGE TRIM, 1/4"	24"
10	88669943	HOSE ASSEMBLY, 10 HYD 96" LG 45	2
11	88669944	HOSE ASSEMBLY, 10 HYD 52" LG	2
12	88669945	HOSE ASSEMBLY, 08 HYD 96" LG 45	2
13	88669947	HOSE ASSEMBLY, 08 HYD 81-1/2" LG	2
14	88669948	HOSE ASSEMBLY, 08 HYD 99-1/2" LG	2
15	88669951	HOSE ASSEMBLY, 04 HYD 23" LG	2
16	88669952	HOSE ASSEMBLY, 04 HYD 50" LG	2
17	88670023	PLT, FRMD, FIELD STOP, BLK	2
18	88670024	PLT, FRMD, FIELD STOP, RED	2
19	88670108	HYD BLOCK ASSEMBLY, LESS WINGS	1
20	SX016626	HOSE, 08 FJI x 08100 R 17 X	2
21	SX21294	HEAVY DUTY CABLE TIE MOUNT	2
22	SX3NS21	BLACK STRAP, 21-1/2"	10
23	SX6801-6-8	HYD ELBOW, 3/8" JIC-3/4" ORB MALE	4
24	SX6801-8	HYD FITTING, 3/4" MO x 1/2" JIC EL	4
25	SX8010-15P	HYD QUICK COUPLER, UNIV. POPPET	2
26	SXLN-038-NIYZ	LOCKNUT, 3/8" NYLON INSERT YZ	10
27	SXPLI038-275	LYNCH PIN, 3/8" x 2-3/4"	4

HYDRAULIC GROUP, W/ INNER AND OUTER WINGS

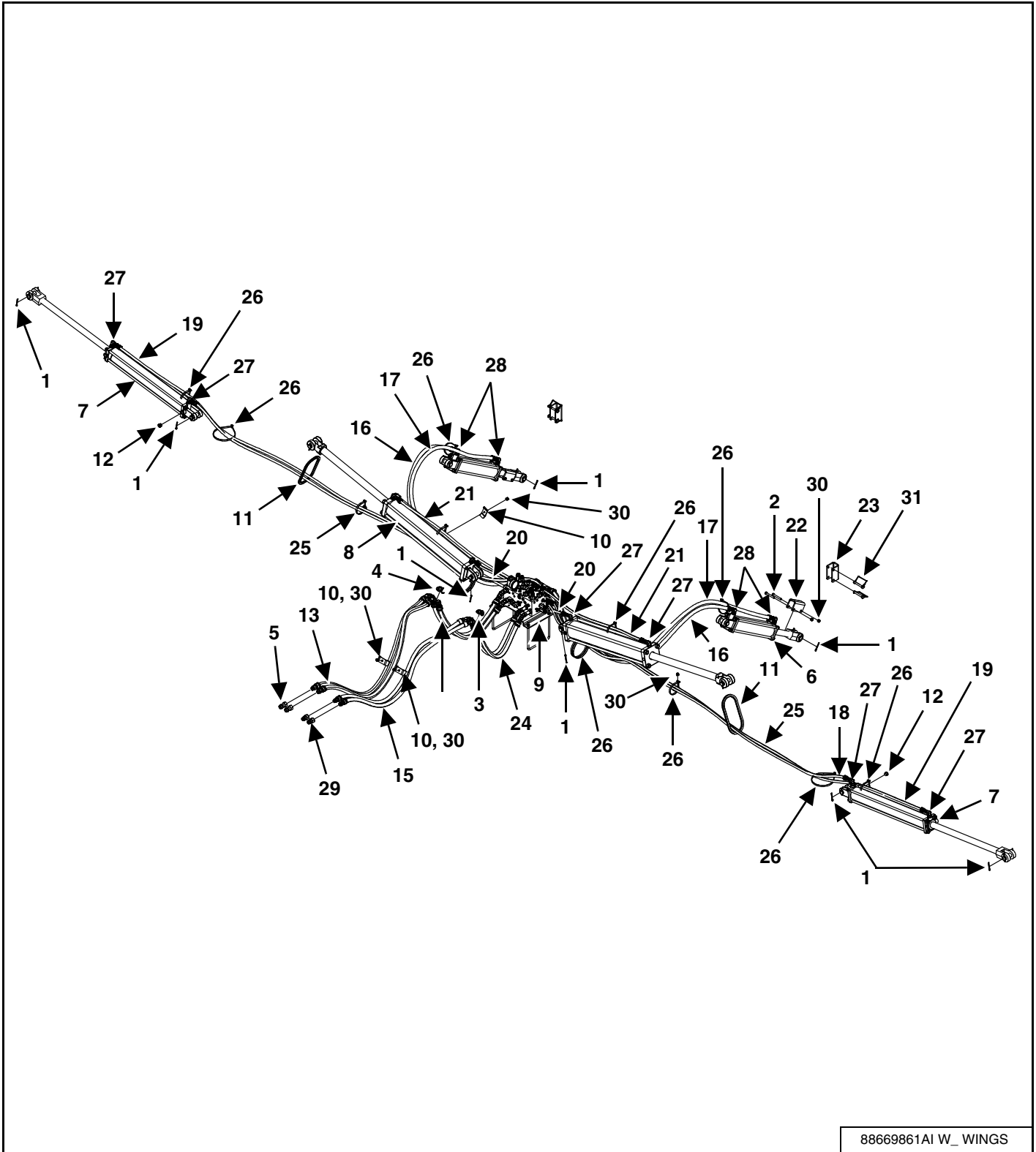

88669861AI W_WINGS

ITEM	PART NUMBER	DESCRIPTION	QTY
1	00087399	CT PN P 0.18 x 1-3/4" 86505604	16
2	00088444	CSHH, 0.38 x 2-3/4" GR 5 P 86505344	4
3	86513097	HYD FITTING, 08 MJIC x 08 MJIC	2
4	86513098	HYD FITTING, -10 MJIC x 10 MJIC	2
5	88663859	CNCTR - HYD QUICK DISCONNECT	2
6	88669217	CYLINDER, 3" x 14" 3000 PSI	2
7	88669221	CYLINDER, 3" x 24" 3000 PSI	2
8	88669444	CYLINDER, 4" x 24" 3000 PSI	2
9	88669892	HYD BLOCK AND FITTINGS ASSEMBLY	1
10	88669896	SHORT HOSE HOLDER BAR	4
11	88669937	EDGE TRIM, 1/4"	24"
12	88669942	HYD PLUG, 08 SAE 3/4-16	2
13	88669943	HOSE ASSEMBLY, 10 HYD 96" LG 45	2
14	88669944	HOSE ASSEMBLY, 10 HYD 52" LG	2
15	88669945	HOSE ASSEMBLY, 08 HYD 96" LG 45	2
16	88669947	HOSE ASSEMBLY, 08 HYD 81-1/2" LG	2
17	88669948	HOSE ASSEMBLY, 08 HYD 99-1/2" LG	2
18	88669949	HOSE ASSEMBLY, 04 HYD 125-1/2" LG	2
19	88669950	HOSE ASSEMBLY, 04 HYD 151" LG	2
20	88669951	HOSE ASSEMBLY, 04 HYD 23" LG	2
21	88669952	HOSE ASSEMBLY, 04 HYD 50" LG	2
22	88670023	PLT, FRMD, FIELD STOP, BLK	2
23	88670024	PLT, FRMD, FIELD STOP, RED	2
24	SX016626	HOSE ASSEMBLY, 08 FJIX x 08 100R 17 X	2
25	SX21294	HEAVY DUTY CABLE TIE MOUNT	2
26	SX3NS21	BLACK STRAP, 21-1/2"	14
27	SX6801-6-8	HYD ELBOW, 3/8" JIC x 3/4" ORB MALE	8
28	SX6801-8	HYD FITTING, 3/4" MO x 1/2" JIC EL	4
29	SX8010-15P	HYD QUICK COUPLER, UNIV. POPPET	2
30	SXLN-038-NIYZ	LOCKNUT, 3/8" NYLON INSERT YZ	10
31	SXPLI038-275	PIN, LYNCH PIN; 3/8" x 2-3/4"	4

HYDRAULIC BLOCK

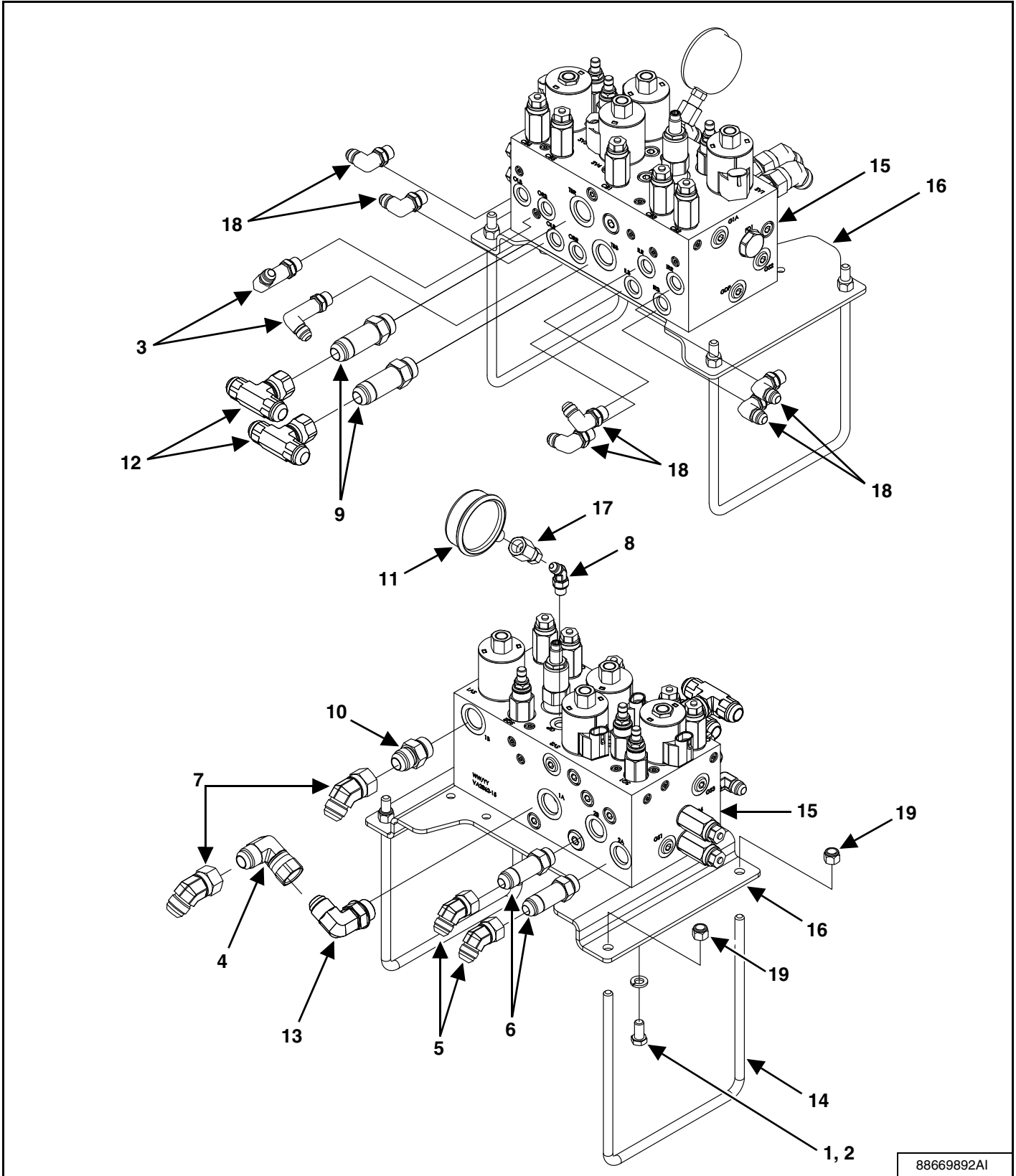

88669892AI

ITEM	PART NUMBER	DESCRIPTION	QTY
1	00012012	CSHH G5 P 0.38" x 3/4"	4
2	00080680	LOCKWASHER, 0.375 PL	4
3	00086526	HYD FITTING, 6 MORB x 6 MJIC	2
4	00182977	90° ELBOW, 37D SWIVL 10 86512105	1
5	00248992	45° HYD FITTING, 8 FJIC x 8 MJIC	2
6	09601710	HYD FITTING 8 MORB x 8 MJIC	2
7	86512960	45° HYD FITTING, 10	2
8	86512993	45° HYD FITTING, 4 MJIC x 4 MORB	1
9	86513066	CONNECTOR, 37D-OR LONG 86512105	2
10	88663808	HYD ADAPTER, 10 MJIC x 10 MORB	1
11	88665155	GAUGE, 3000 PSI, GLYCERINE FILLED	1
12	88665156	RUN TEE, 10 MJ x 10 MJ x 10 FJ	2
13	88665158	90° ELBOW, 10 MORB x 10 MJIC	1
14	88669540	U-BOLT, 3/8" x 7" x 8-1/4" GR 5 SQ YZ	2
15	88669715	HYD BLOCK ASSEMBLY, MID SIZE APPLICATOR	1
16	88669881	HYD BLOCK BASE PLATE	1
17	88669893	HYD FITTING, 4 FPIPE x 4 FJIC	1
18	SX6801-6	90° ELBOW ADPTR, 06 MJIC x 06 ORB	6
19	SXLN-038-NIYZ	LOCKNUT, 3/8" NYLON INSERT YZ	4

HYDRAULIC BLOCK COMPONENTS

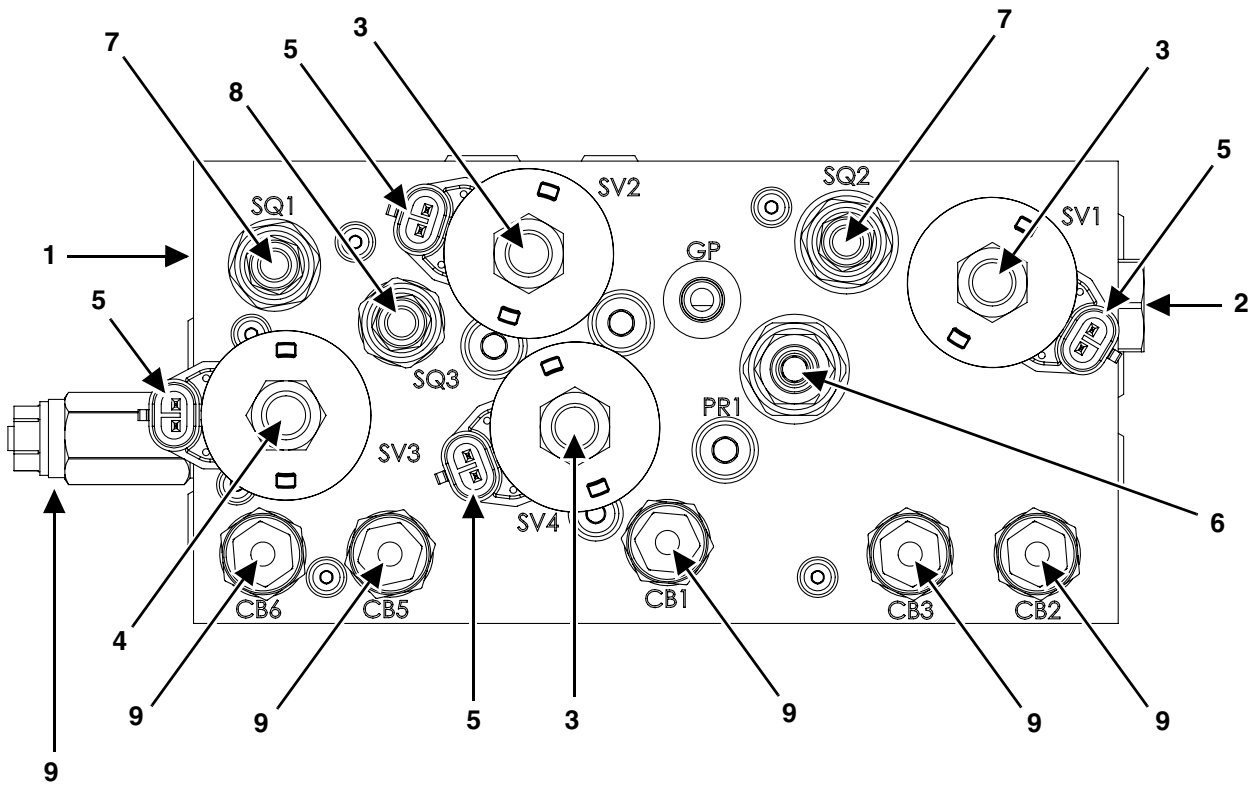

88669715

ITEM	PART NUMBER	DESCRIPTION	QTY
1	88670408	BLOCK, 45FT APP-V2	1
2	88670409	#10 FLOW DIV/COM (FD1)	1
3	88670410	#10 POPPET, 2 WAY NORMALLY OPEN (SV1, SV2, SV4)	3
4	88674011	#10 POPPET, 2 WAY N.C., BI-DIRECTIONAL (SV3)	1
5	88670412	E-COIL, 12VDC, METRI-PACK (SV1 - SV4)	4
6	88670404	#10 PRES RED/REL VLV (PR1)	1
7	88670413	SUN T-11A SEQUENCE VLV W/REV CHECK (SQ1, SQ2)	2
8	88670414	SUN T-11A SEQUENCE VLV W/REV CHECK 1500PSI (SQ3)	1
9	88670406	VLV CB 5:1 (CB1 - CB7)	7

RAVEN 450 (OPTIONAL)

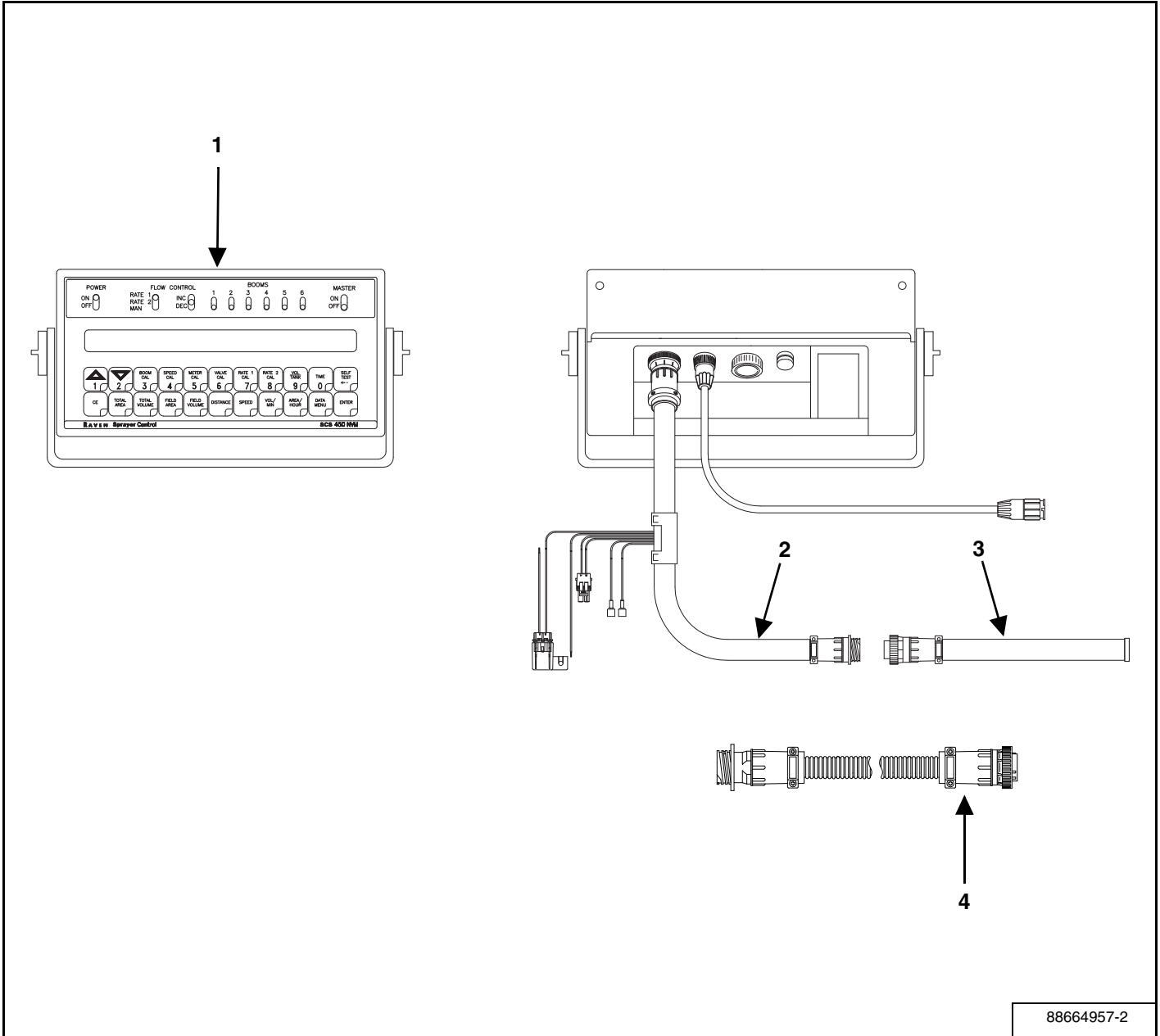

ITEM	PART NUMBER	DESCRIPTION	QTY
1	SX063-0171-220	CONSOLE ASSY, 450 W/SERIAL PORT	1
2	SX115-0171-085	CABLE, RAVEN 450 CONTROL CABLE	1
3	88664958	CABLE, FLOW CONTROL 43 FT 6 SECT	1
4	88668923	16' - 7 BOOM CABLE	1

RAVEN VIPER 4 W / GPS (OPTIONAL)

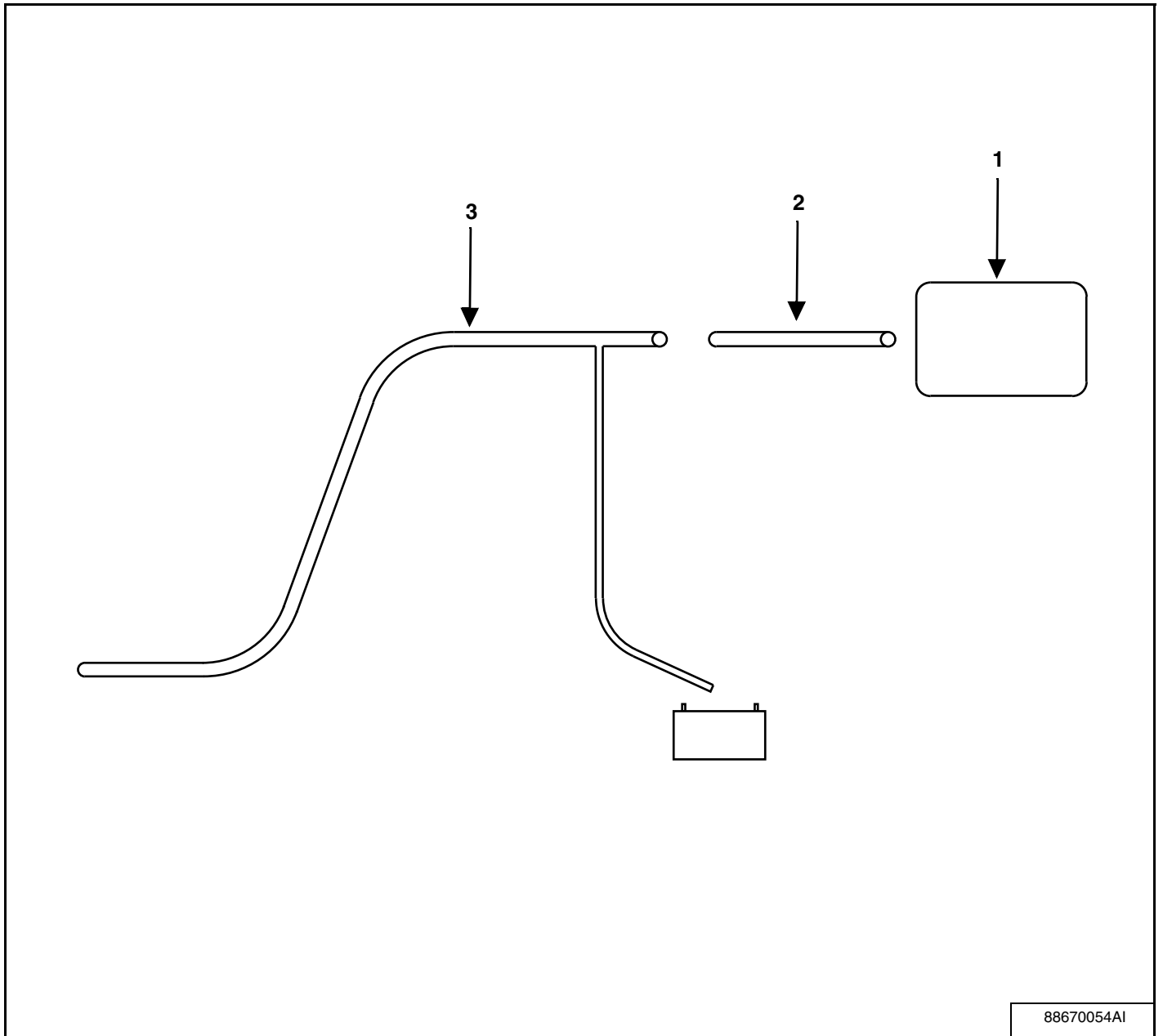

ITEM	PART NUMBER	DESCRIPTION	QTY
1	88668524	KIT, VIPER 4 W/GPS. BUHLER	1
2	88670162	CABLE, CONSOLE, VIPER 4	1
3	88670163	CABLE, CHASSIS, VIPER 4	1

ISOBUS (OPTIONAL)

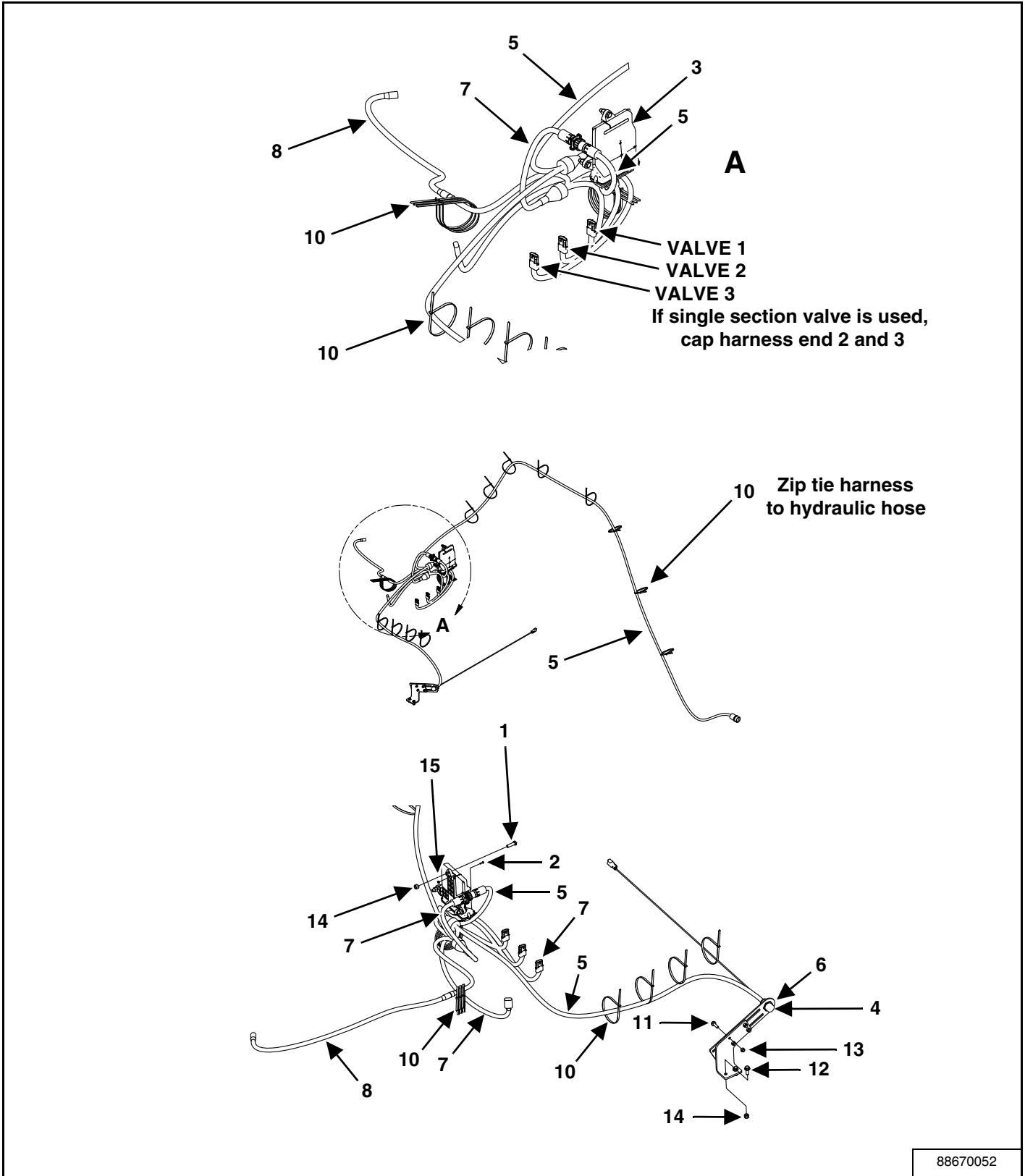

ITEM	PART NUMBER	DESCRIPTION	QTY
1	00088011	BOLT, 0.38" x 1-1/4" CSHH GR 5 P 86505344	3
2	00281007	MS PAN P #6 x 1/2" 86505592	4
3	88668850	NODE, 1860/2460 CONTROLLER	1
4	88668925	PROXIMITY SWITCH	1
5	88668936	LIQUID CONTROL CABLE, ISO, BU	1
6	88668957	PLATE, MNT, SLIDE, PROXY SWITCH	1
7	88669047	CABLE, LIQ, BVI 1410/1460 3 SEC	1
8	88670055	FLOWMETER HARNESS, 6' EXTEN.	1
9	88670056	PROXIMITY SENSOR BASE PLATE	1
10	SX3NS12	STRAP, 11-1/4" BLA 21	18
11	SXBHF0311008YZ	BOLT, 5/16" x 1" FLG, GR 8 YLLW ZN	4
12	SXBHF0381008YZ	BOLT, 3/8" x 1" FLG, GR8 YLLWZN	2
13	SXLN-031-NIYZ	LOCKNUT, 5/16" NYLON INSERT YZ	4
14	SXLN-038-NIYZ	LOCKNUT, 3/8" NYLON INSERT YZ	5
15	SXLN-06-32-NI-S	LOCKNUT, 6/32" NYLON INSERT	4

SCS440 / 450 HARNESS ONLY (OPTIONAL)

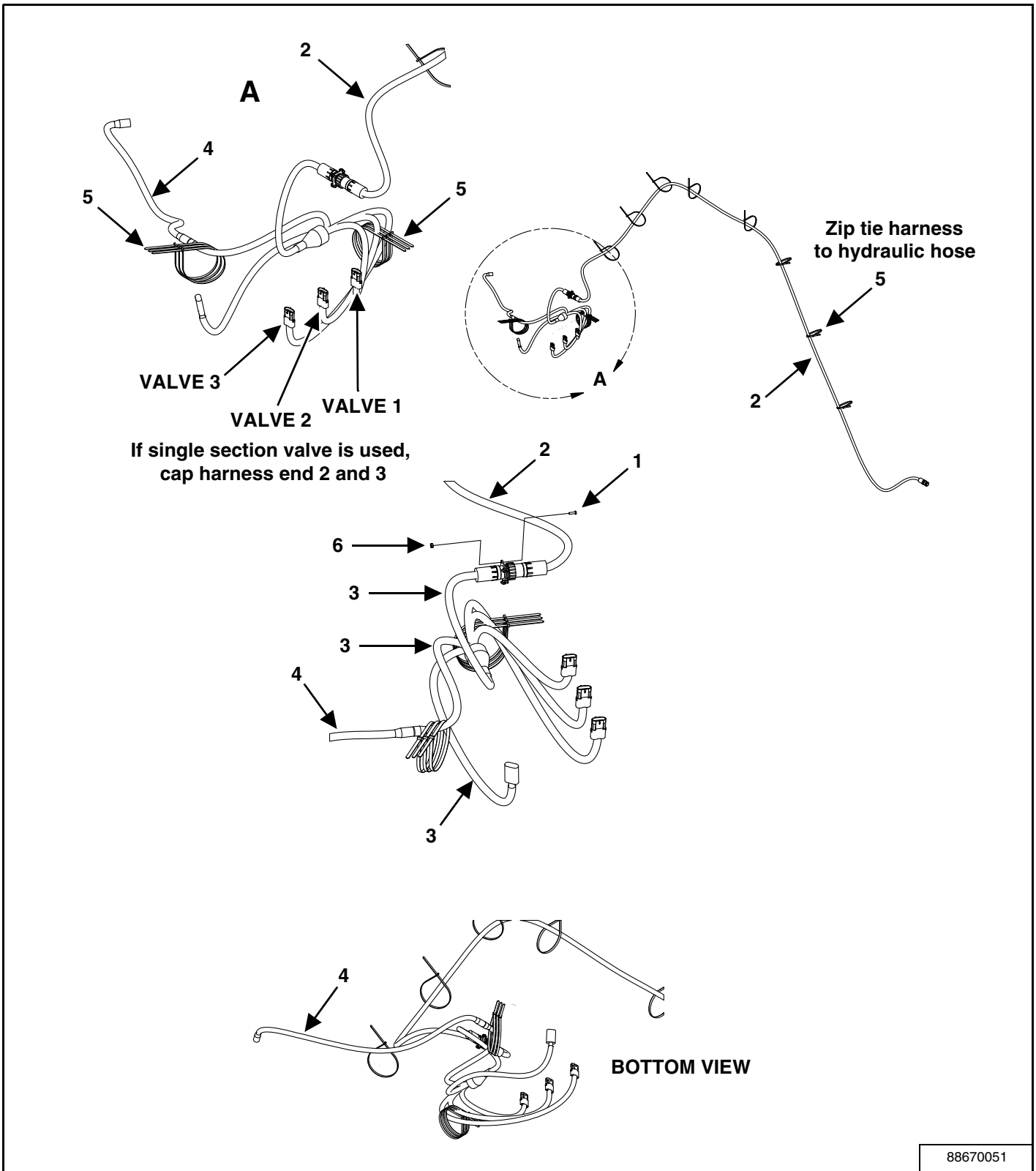

88670051

ITEM	PART NUMBER	DESCRIPTION	QTY
1	00281007	MS PAN P #6 x 1/2" 86505592	4
2	88668923	CABLE, 16' EXT, 7 BOOM SCS 440	1
3	88669047	CABLE, LIQ, BVI 1410/1460 3 SEC	1
4	88670055	FLOWMETER HARNESS, 6' EXTEN.	1
5	SX3NS12	STRAP, 11-1/4" BLA 21	14
6	SXLN-06-32-NI-S	LOCKNUT, 6/32 NYLON INSERT	4

RAVEN PHOENIX 10 GPS (OPTIONAL)

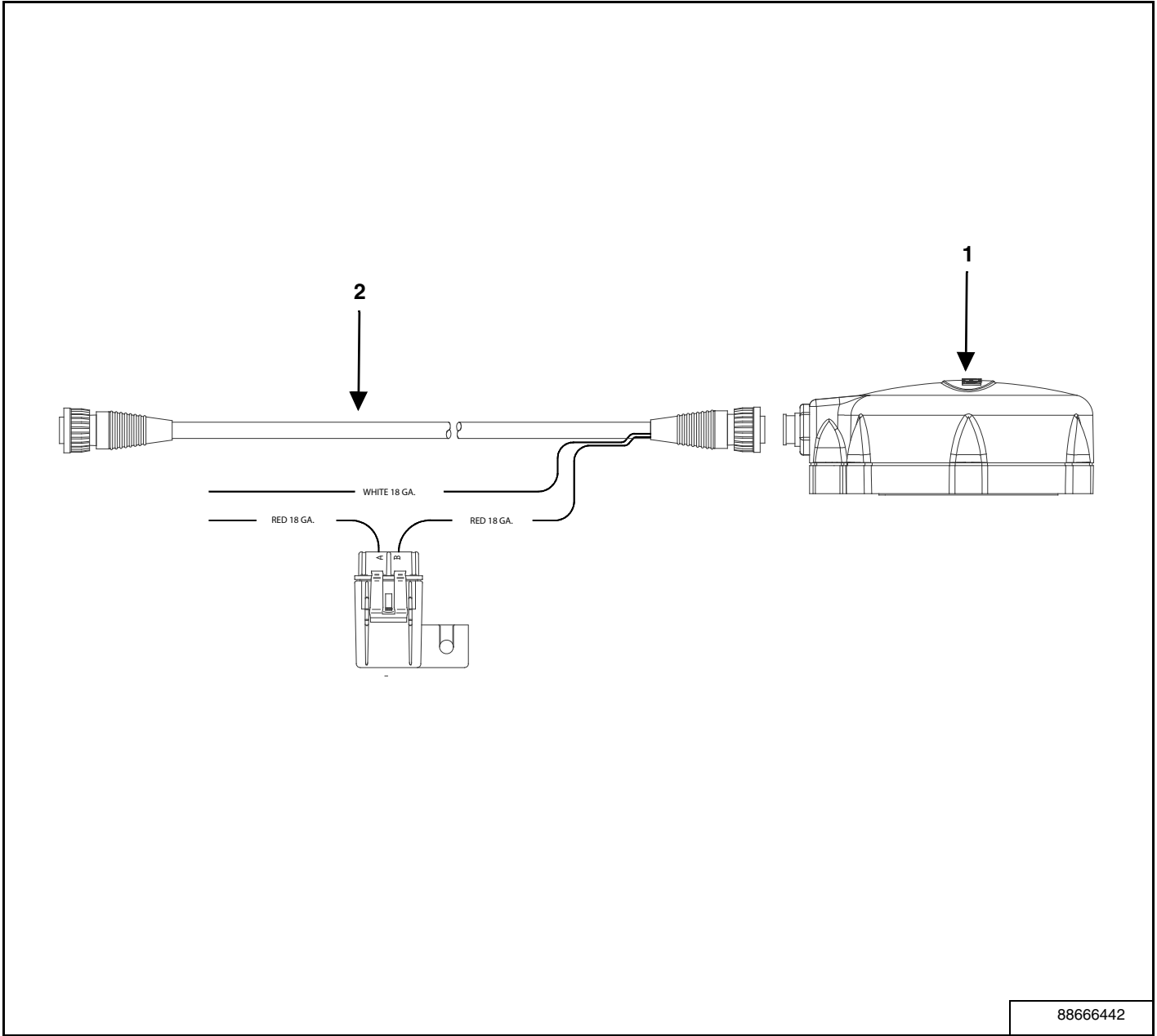

ITEM	PART NUMBER	DESCRIPTION	QTY
1	88666443	PHOENIX 10 RECEIVER	1
2	88666444	RECEIVER CABLE	1

OUTER WING CYLINDER

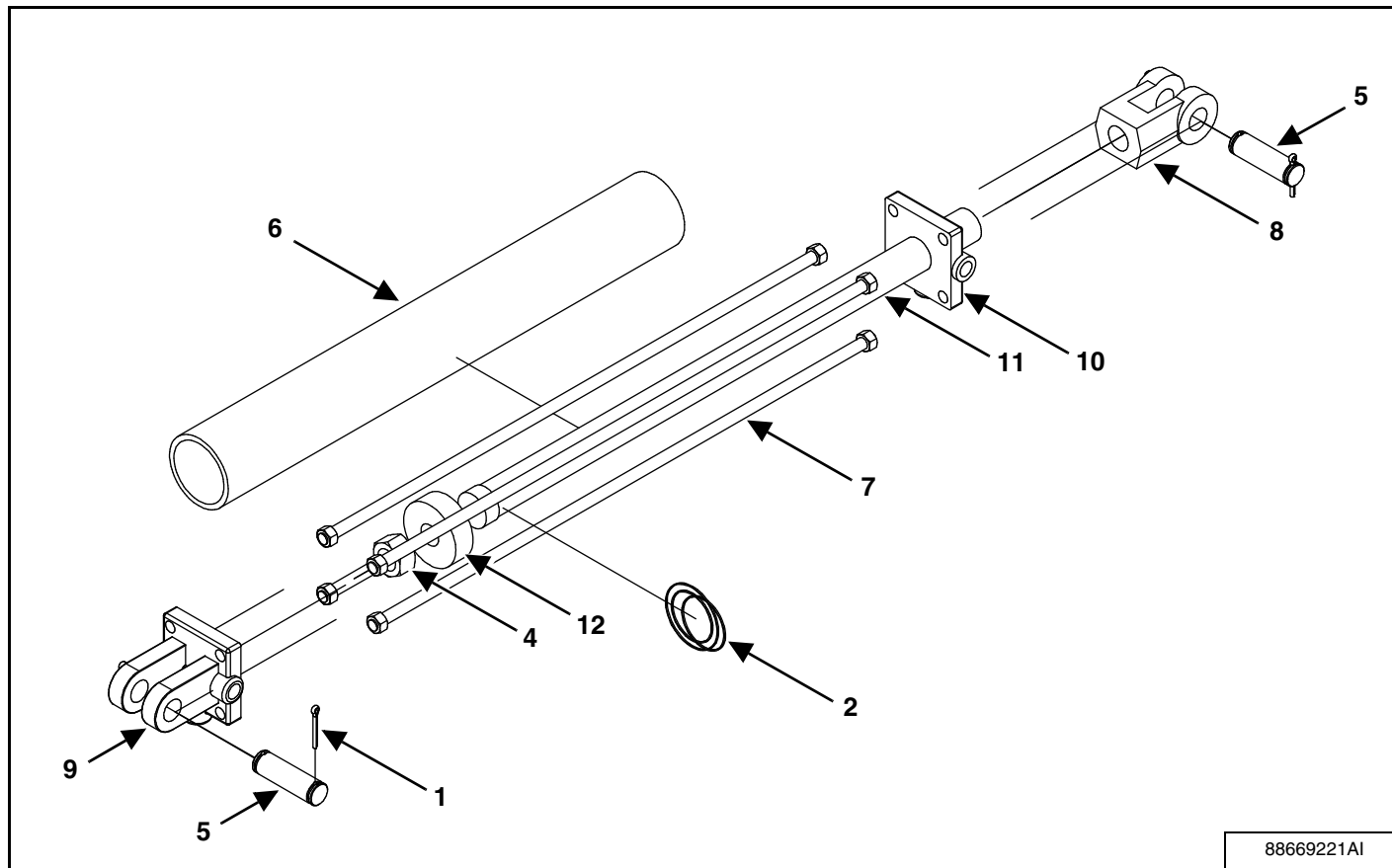

88669221AI

ITEM	PART NUMBER	DESCRIPTION	QTY
1	00080754	COTTER PIN, 3/16" x 1-1/2"	4
2	88670306	SEAL REPAIR KIT	1
3	SX125250	NUT, HEX (TIE ROD)	8
4	SX130560	NUT, HEX (CYL. ROD)	1
5	SX134953	CYLINDER PIN	2
6	88670309	CYLINDER TUBE	1
7	88669223	TIE ROD	4
8	SX492652	ROD CLEVIS	1
9	SX492675	CLEVIS CAP	1
10	88670310	ROD CAP	1
11	88669222	CYLINDER ROD	1
12	88670308	PISTON	1

INNER WING CYLINDER

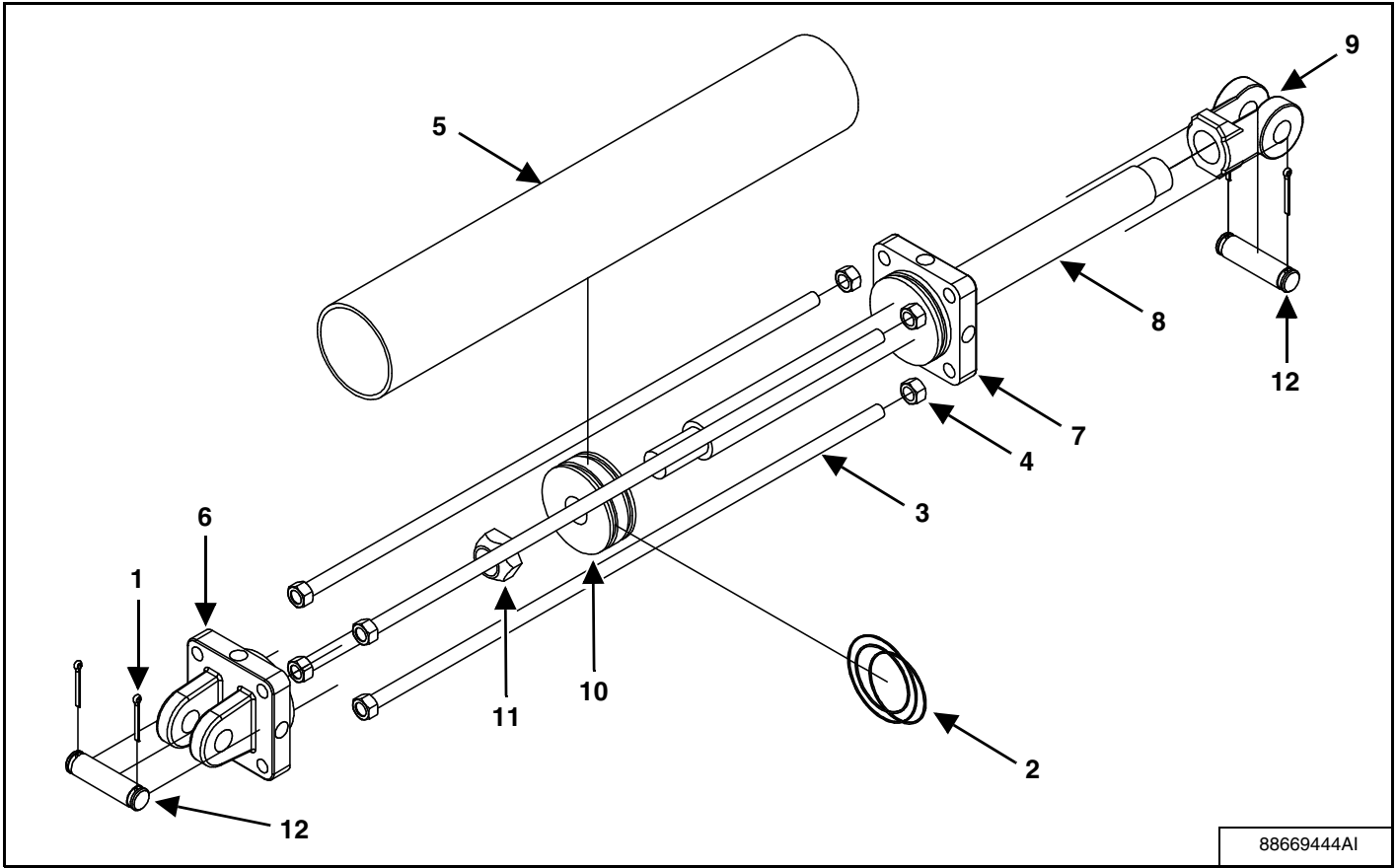

88669444AI

ITEM	PART NUMBER	DESCRIPTION	QTY
1	00087399	CT PN P 0.18" x 1-3/4" 86505604	4
2	88670311	SEAL REPAIR KIT	1
3	88670321	TIE ROD	4
4	88670322	NUT, HEX (TIE ROD)	8
5	88670323	TUBE	1
6	88670324	BUTT	1
7	88670325	ROD CAP	1
8	88670326	PISTON ROD	1
9	88670327	CLEVIS ASSEMBLY	1
10	88670328	PISTON	1
11	88670329	LOCKNUT 1.125-12UNF	1
12	88670330	CLEVIS PIN	2

MAIN LIFT CYLINDER

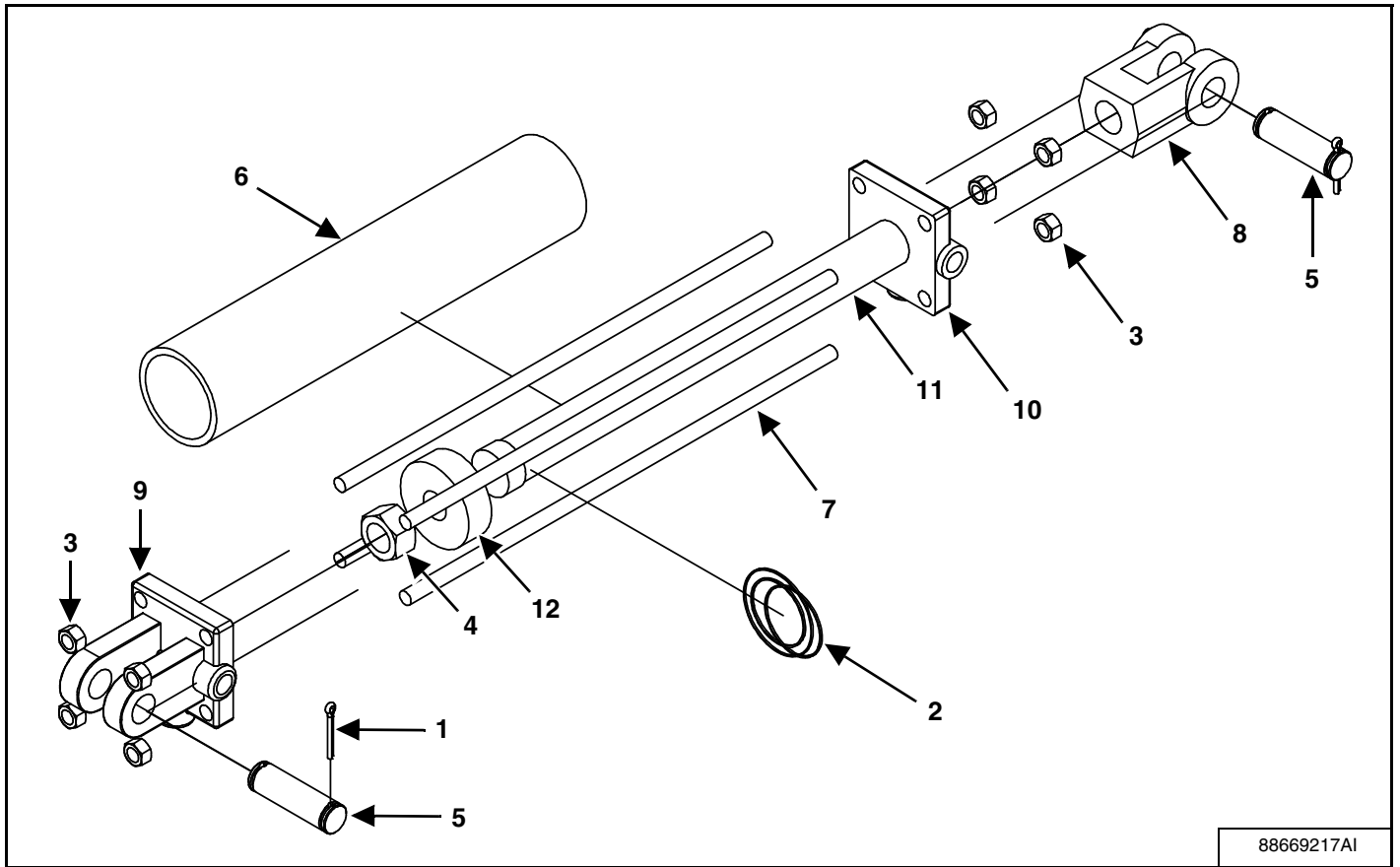

88669217A1

ITEM	PART NUMBER	DESCRIPTION	QTY
1	00080754	COTTER PIN, 3/16" x 1-1/2"	4
2	88670306	SEAL REPAIR KIT	1
3	SX125250	NUT, HEX (TIE ROD)	8
4	SX130560	NUT, HEX (CYL. ROD)	1
5	SX134953	CYLINDER PIN	2
6	88669220	CYLINDER TUBE	1
7	88669219	TIE ROD	4
8	SX492652	ROD CLEVIS	1
9	SX492675	CLEVIS CAP	1
10	88670307	ROD CAP	1
11	88669218	CYLINDER ROD	1
12	88670308	PISTON	1

Farm King



SPECIFICATIONS

SPECIFICATIONS203
 Dimensions203
 Performance203

HYDRAULIC SCHEMATIC (W / INNER WINGS ONLY)204

HYDRAULIC SCHEMATIC (W / INNER AND OUTER WINGS)205

HYDRAULIC / ELECTRICAL SCHEMATIC206

HARDWARE TORQUE VALUES207
 Metric Chart207
 Imperial Chart208

HYDRAULIC CONNECTION SPECIFICATIONS209
 O-Ring Fitting (Straight Thread)209
 O-ring Face Seal Connection209
 Flare Fitting209
 Port Seal (O-ring Boss) Fitting209
 Tubelines And Hoses209

NOZZLE SELECTION210
 Density Correction Chart210

NOZZLE SPECIFICATIONS211

Farm King



SPECIFICATIONS

Dimensions

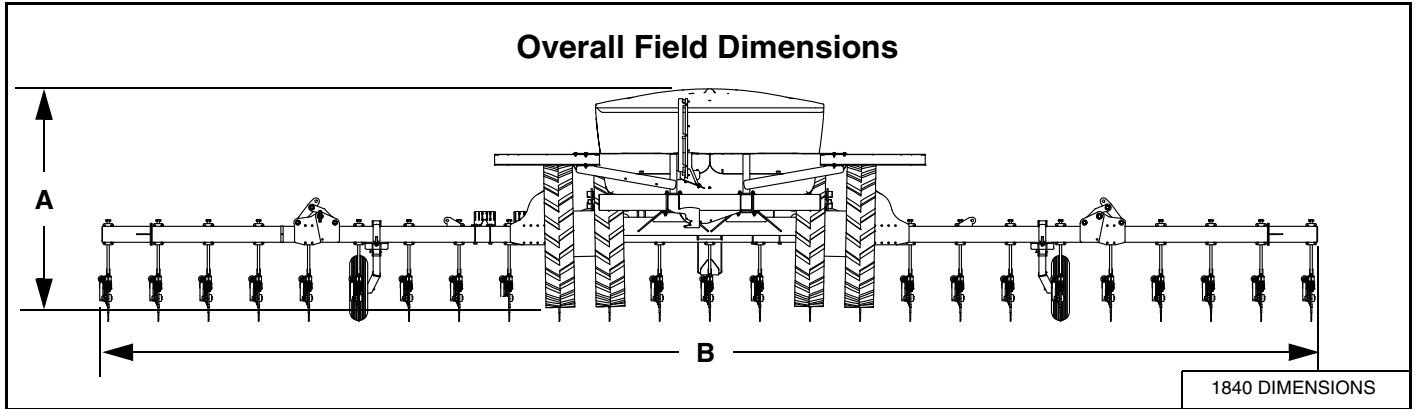

DESCRIPTION	1840
Overall Field Height (A)	8 ft. 8 in.
Overall Field Width (B)	44 ft. 5 in.
Transport Width (w/ Coulters Installed)	17 ft. 9 in.
Transport Height	13 ft. 3 in.
Transport Length	21 ft. 8 in.
Pin To Axle	14 ft. 7 in.
Empty Weight	12,680 lbs.
Tongue Weight (transport)	3,820 lbs.
Tongue Weight (field position, fully raised)	3,820 lbs.

NOTE: Dimensions are approximate measurements.

Performance

DESCRIPTION	1840
Product Tank	1800 U.S. gal.
Fresh Water Safety Tank	9 U.S. gal.
Plumbing	Ace Hydraulic Driven Centrifugal Pump Kit • 1 or 3 Section Control Valves Raven SCD 450, Raven Viper 4, Raven ISOBUS
Toolbar	Available in 20", 22", 30" and 38" row spacings up to 45 ft.
Coulters	20 in. Ripple, Spring - Cushioned (Knives or Injectors)
Gauge Wheels	2
Tires	Single 320/90 R50, Single 380/90 R46, Dual 320/90 R46, Dual 380/90 R46
Wheel Spacing	60 in. / 120 in., 76 in. / 152 in., 80 in. / 120 in., 88 in. / 132 in. Duals
Ground Clearance	36" crop clearance, 30" ground clearance on turn rows.
Electrical Harness	7-Pin Implement Harness, 3-Pin Mode Selector Harness

HYDRAULIC SCHEMATIC (W / INNER AND OUTER WINGS)

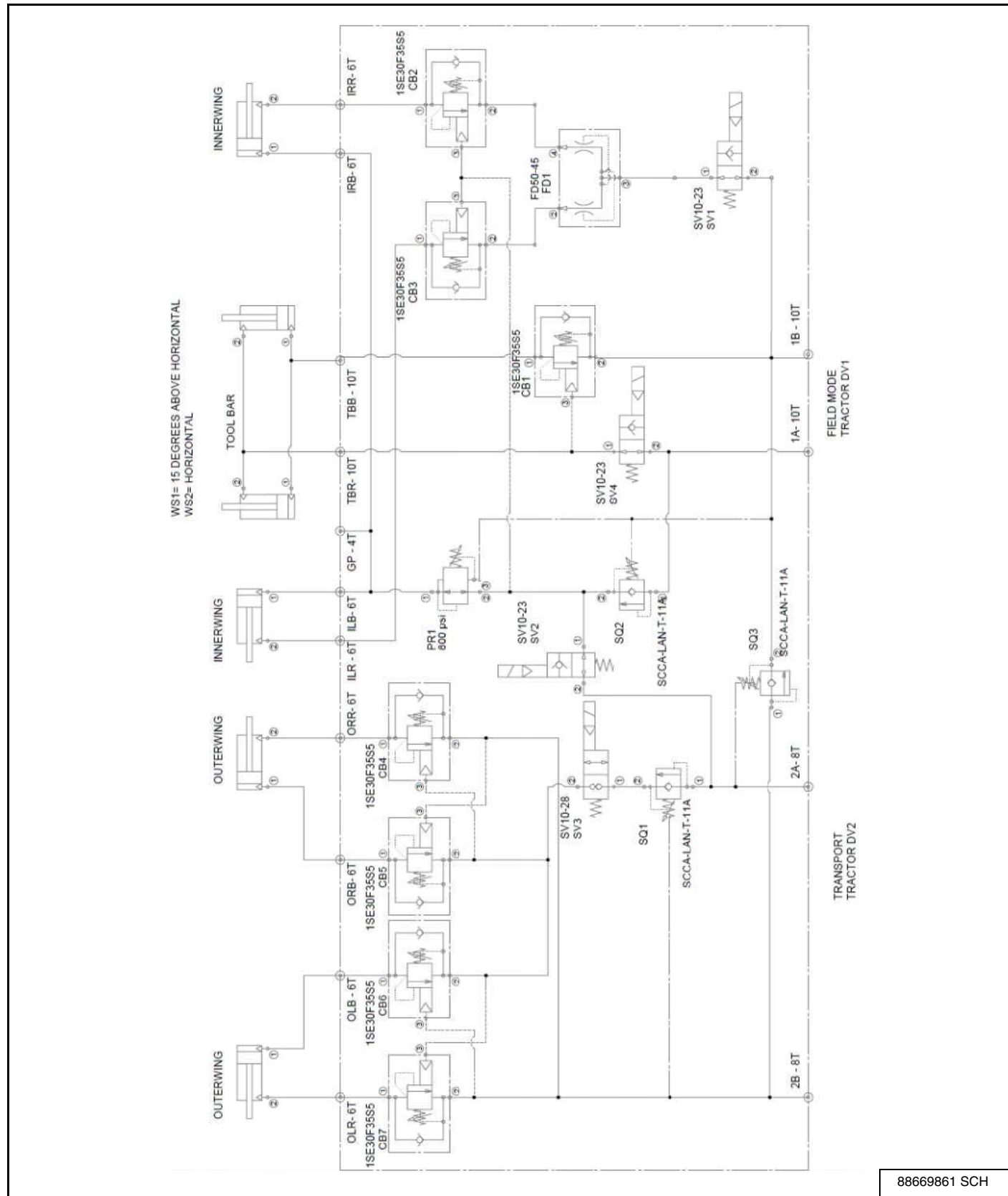

HYDRAULIC / ELECTRICAL SCHEMATIC

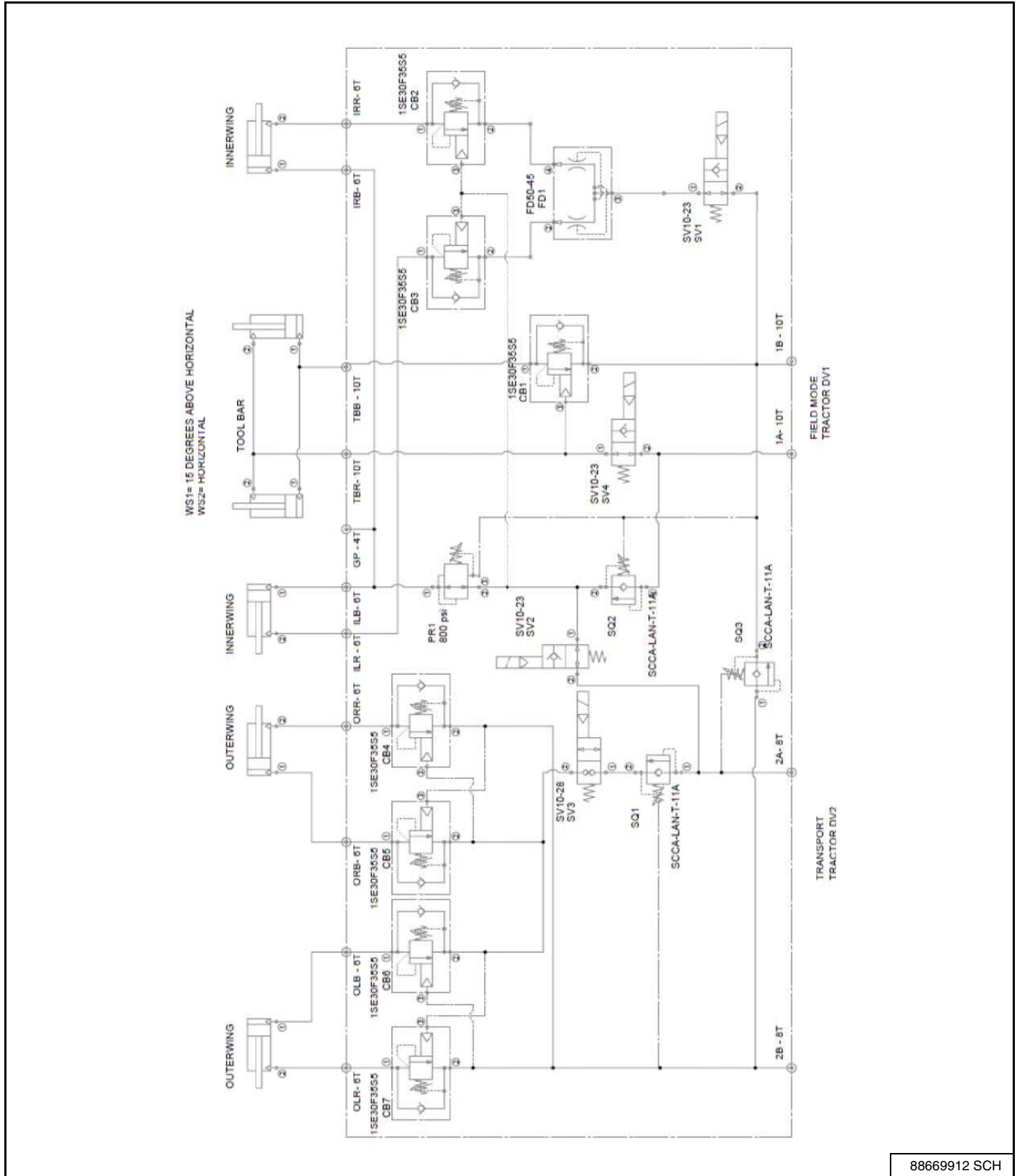

HARDWARE TORQUE VALUES

Metric Chart

NOTE: Do not use the values listed in the charts if a different torque value or tightening procedure is specified in this manual for a specific application. Torque values listed are for general use only.

Use the following charts to determine the correct torque when checking, adjusting or replacing hardware. **Torque values are listed in newton-meters (inch* or foot pounds) for normal assembly applications.**

Nominal Size	Class 5.8		Class 8.8		Class 10.9		Lock nuts
	Unplated	Plated W / ZnCr	Unplated	Plated W / ZnCr	Unplated	Plated W / ZnCr	CL.8 w/ CL. 8.8 Bolt
M4	1.7 (15*)	2.2 (19*)	2.6 (23*)	3.4 (30*)	3.7 (33*)	4.8 (42*)	1.8 (16*)
M6	5.8 (51*)	7.6 (67*)	8.9 (79*)	12 (102*)	13 (115*)	17 (150*)	6.3 (56*)
M8	14 (124*)	18 (159*)	22 (195*)	28 (248*)	31 (274*)	40 (354*)	15 (133*)
M10	28 (21)	36 (27)	43 (32)	56 (41)	61 (45)	79 (58)	30 (22)
M12	49 (36)	63 (46)	75 (55)	97 (72)	107 (79)	138 (102)	53 (39)
M16	121 (89)	158 (117)	186 (137)	240 (177)	266 (196)	344 (254)	131 (97)
M20	237 (175)	307 (226)	375 (277)	485 (358)	519 (383)	671 (495)	265 (195)
M24	411 (303)	531 (392)	648 (478)	839 (619)	897 (662)	1160 (855)	458 (338)

NOTE: Torque values shown with * are inch pounds.

Identification of Hex Cap Screws and Carriage Bolts - Classes 5 and up

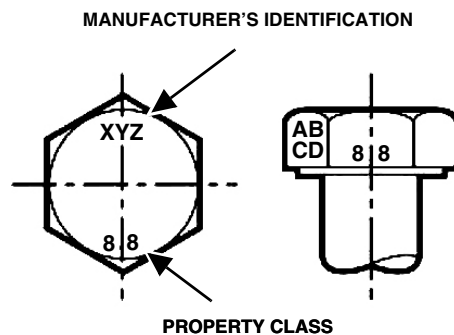

Identification of Hex Nuts and Lock Nuts - Classes 5 and up

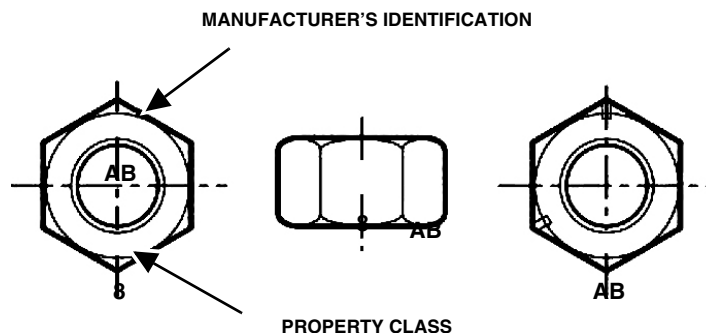

HARDWARE TORQUE VALUES (CONT'D)

Imperial Chart

NOTE: Do not use the values listed in the charts if a different torque value or tightening procedure is specified in this manual for a specific application. Torque values listed are for general use only.

Use the following charts to determine the correct torque when checking, adjusting or replacing hardware. **Torque values are listed in newton-meters (inch* or foot pounds) for normal assembly applications.**

Nominal Size	SAE Grade 5		SAE Grade 8		LOCK NUTS			
	Unplated or Plated Silver	Plated W / ZnCr Gold	Unplated or Plated Silver	Plated W / ZnCr Gold	Unplated or Plated Silver	Plated W / ZnCr Gold	Grade W / Gr. 5 Bolt	Grade W / Gr. 8 Bolt
1/4	6.2 (55*)	8.1 (72*)	9.7 (86*)	12.6 (112*)	13.6 (121*)	17.7 (157*)	6.9 (61*)	9.8 (86*)
5/16	13 (115*)	17 (149*)	20 (178*)	26 (229*)	28 (250*)	37 (324*)	14 (125*)	20 (176*)
3/8	23 (17)	30 (22)	35 (26)	46 (34)	50 (37)	65 (48)	26 (19)	35 (26)
7/16	37 (27)	47 (35)	57 (42)	73 (54)	80 (59)	104 (77)	41 (30)	57 (42)
1/2	57 (42)	73 (54)	87 (64)	113 (83)	123 (91)	159 (117)	61 (45)	88 (64)
9/16	81 (60)	104 (77)	125 (92)	163 (120)	176 (130)	229 (169)	88 (65)	125 (92)
5/8	112 (83)	145 (107)	174 (128)	224 (165)	244 (180)	316 (233)	122 (90)	172 (127)
3/4	198 (146)	256 (189)	306 (226)	397 (293)	432 (319)	560 (413)	217 (160)	306 (226)
7/8	193 (142)	248 (183)	495 (365)	641 (473)	698 (515)	904 (667)	350 (258)	494 (364)
1	289 (213)	373 (275)	742 (547)	960 (708)	1048 (773)	1356 (1000)	523 (386)	739 (545)

NOTE: Torque values shown with * are inch pounds.

Identification of Hex Cap Screws and Carriage Bolts

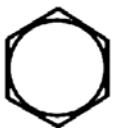

SAE GRADE 2 BOLTS



SAE GRADE 5 BOLTS



SAE GRADE 8 BOLTS



SAE GRADE 2 NUTS



SAE GRADE 2 NUTS



SAE GRADE 2 NUTS

Identification of Hex Nuts and Lock Nuts

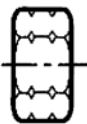

Grade A - No Notches

Grade B - One Circumferential Notch

Grade C - One Circumferential Notches

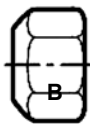

Grade A - No Mark

Grade B - Letter B

Grade C - Letter C

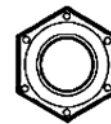

Grade A - No Marks

Grade B - Three Marks

Grade C - Six Marks

(Marks not always located at corners)

HYDRAULIC CONNECTION SPECIFICATIONS

O-Ring Fitting (Straight Thread)

Lubricate the O-ring before installing the fitting. Loosen the jam nut and install the fitting. Tighten the jam nut until the washer is tight against the surface.

O-ring Face Seal Connection

Figure 55

O-ring Face Seal Tightening Torque		
Tubeline O.D.	Thread Size	N•m (ft-lb)
1/4"	9/16" - 18	13 (18)
3/8"	11/16" - 16	22 (30)
1/2"	13/16" - 16	40 (54)
5/8"	1" - 14	60 (81)
3/4"	1-3/16" - 12	84 (114)
7/8"	1-3/16" - 12	98 (133)
1"	1-7/16" - 12	118 (160)
1-1/4"	1-11/16" - 12	154 (209)
1-1/2"	2" - 12	163 (221)

When the fitting is tightened, you can feel when the fitting is tight to eliminate leakage caused by under or over torqued fittings. Use petroleum jelly to hold the O-ring in position until the fittings are assembled [Figure 55].

Flare Fitting

Figure 56

Flare Fitting Tightening Torque		
Tubeline O.D.	Thread Size	N•m (ft-lb)
1/4"	7/16" - 20	13 (18)
5/16"	1/2" - 20	17 (23)
3/8"	9/16" - 18	22 (30)
1/2"	3/4" - 16	40 (54)
5/8"	7/8" - 14	60 (81)
3/4"	1-1/16" - 12	84 (114)
7/8"	1-3/16" - 12	98 (133)
1"	1-5/16" - 12	118 (160)
1-1/4"	1-5/8" - 12	154 (209)
1-1/2"	1-7/8" - 12	163 (221)
2"	2-1/2" - 12	252 (342)

Tighten until the nut makes contact with the seat. Use the chart [Figure 56] to find the correct tightness needed.

NOTE: If the fitting leaks, disconnect and inspect the seat area for damage.

Port Seal (O-ring Boss) Fitting

Figure 57

Port Seal And O-ring Boss Tightening Torque		
Tubeline O.D.	Thread Size	N•m (ft-lb)
1/4"	7/16" - 20	13 (18)
3/8"	9/16" - 18	22 (30)
1/2"	3/4" - 16	40 (54)
5/8"	7/8" - 14	60 (81)
3/4"	1-1/16" - 12	84 (114)
7/8"	1-3/16" - 12	98 (133)
1"	1-5/16" - 12	118 (160)
1-1/8"	1-7/16" - 12	154 (209)
1-1/4"	1-5/8" - 12	163 (221)

NOTE: Port seal and nut, washer and O-ring (O-ring Boss) fittings use the same tightening torque valve chart [Figure 57].

If a torque wrench cannot be used, use the following method.

Tighten the nut until it just makes metal to metal contact, you can feel the resistance.

Tighten the nut with a wrench no more than one hex flat maximum.

Do not over tighten the port seal fitting.

NOTE: If a torque wrench cannot be used, use the hex flat tightening method as an approximate guideline.

NOTE: Port seal fittings are not recommended in all applications. Use O-ring boss fittings in these applications.

Tubelines And Hoses

Replace any tubelines that are bent or flattened. They will restrict flow, which will slow hydraulic action and cause heat.

Replace hoses which show signs of wear, damage or weather cracked rubber.

Always use two wrenches when loosening and tightening hose or tubeline fittings.

NOZZLE SELECTION

Use the following formula to convert pounds per acre to gallons per minute (gpm):

$$\frac{\text{Total lb. per acre}}{\text{of nitrogen}} = \frac{\text{Target lb. per acre}}{\text{Percent of nitrogen}}$$

$$\frac{\text{Total lb. per acre}}{\text{Pound per gallon}} = \text{GPA}$$

EXAMPLE - The desired output is 100 lbs of nitrogen per acre. In order to get 100 lbs of nitrogen you need to apply 357 lbs of 28% nitrogen solution per acre. 357 lbs per acre of a solution that weighs 10.65 lbs per gallon equals 33.53 gallons per acre (GPA). Select a nozzle that will provide 33.53 GPA at your desired system pressure.

$$\frac{\text{Total lb. per acre: 357}}{\text{of nitrogen}} = \frac{100}{0.28}$$

$$\frac{357}{10.65} = 33.53 \text{ GPA}$$

Density Correction Chart

WEIGHT OF SOLUTION PER GALLON	EXAMPLE	SPECIFIC GRAVITY	CONVERSION FACTOR
7.00 lb.		0.84	0.92
8.00 lb.		0.96	0.98
8.34 lb.	Water	1.00	1.00
9.00 lb.		1.08	1.04
10.00 lb.		1.20	1.10
10.65 lb.	28% Nitrogen	1.28	1.13
11.00 lb.	7 - 27 - 7 Fertilizer	1.32	1.15
11.06 lb.	32% Nitrogen	1.33	1.15
11.40 lb.	10 - 34 - 0 Fertilizer	1.37	1.17
11.50 lb.	12 - 0 - 0 - 26 Fertilizer	1.38	1.17
11.60 lb.	11 - 37 - 0 Fertilizer	1.43	1.20
12.00 lb.		1.44	1.20
14.00 lb.		1.68	1.30

Additional Useful Formula:

$$\text{GPM (per nozzle)} = \frac{\text{GPA} \times \text{MPH} \times \text{W}}{5940}$$

$$\text{GPA} = \frac{\text{GPM (per nozzle)} \times 5940}{\text{MPH} \times \text{W}}$$

$$\text{MPH} = \frac{\text{Distance in feet} \times 60}{\text{Time in seconds} \times 88}$$

W = Nozzle spacing in inches

Spacing Correction Chart

NOZZLE SPACING	CONVERSION FACTOR	GPA Target Conversion Factor = Corrected GPA
22 in.	1.36	
36 in.	0.83	
38 in.	0.79	

NOTE: For nozzle spacing not shown, use this formula: Conversion Factor = $\frac{\text{Nozzle spacing in table}}{\text{Your nozzle spacing}}$

NOZZLE SPECIFICATIONS

NOZZLE*	PSI	GPM (Per Nozzle)	GPA AT 30" NOZZLE SPACING**			
			4 MPH	6 MPH	8 MPH	10 MPH
H1/4U - SS0004	10	0.20	9.9	6.6	5.0	4.0
	20	0.28	13.9	9.2	6.9	5.5
	30	0.35	17.3	11.6	8.7	6.9
	40	0.40	19.8	13.2	9.9	7.9
H1/4U - SS0006	10	0.30	14.9	9.9	7.4	5.9
	20	0.42	20.8	13.9	10.4	8.3
	30	0.52	25.7	17.2	12.9	10.3
	40	0.60	29.7	19.8	14.9	11.9
H1/4U - SS0008	10	0.40	19.8	13.2	9.9	7.9
	20	0.57	28.2	18.8	14.1	11.3
	30	0.69	34.2	22.8	17.1	13.7
	40	0.80	39.6	26.4	19.8	15.8
H1/4U - SS0010	10	0.50	24.8	16.5	12.4	9.9
	20	0.71	35.1	23.4	17.6	14.1
	30	0.87	43.1	28.7	21.5	17.2
	40	1.00	49.5	33.0	24.8	19.8
H1/4U - SS0015	10	0.75	37.1	24.8	18.6	14.9
	20	1.06	52.5	35.0	26.2	21.0
	30	1.30	64.4	42.9	32.2	25.7
	40	1.50	74.3	49.5	37.1	29.7
H1/4U - SS0020	10	1.00	49.5	33.0	24.8	19.8
	20	1.41	69.8	46.5	34.9	27.9
	30	1.73	85.6	57.1	42.8	34.3
	40	2.00	99.0	66.0	49.5	39.6
H1/4U - SS0030	10	1.50	74.3	49.5	37.1	29.7
	20	2.12	104.9	70.0	52.5	42.0
	30	2.60	128.7	85.8	64.4	51.5
	40	3.00	148.5	99.0	74.3	59.4
H1/4U - SS0040	10	2.50	123.8	82.5	61.9	49.5
	20	3.54	175.2	116.8	87.6	70.1
	30	4.53	224.2	149.5	112.1	89.7
	40	5.00	247.5	165.0	123.8	99.0
H1/4U - SS0050	10	3.00	148.5	99.0	74.3	59.4
	20	4.24	209.9	139.9	104.9	84.0
	30	5.20	257.4	171.6	128.7	103.0
	40	6.00	297.0	198.0	148.9	84.0
H1/4U - SS0060	10	3.00	148.5	99.0	74.3	59.4
	20	4.24	209.9	139.9	104.9	84.0
	30	5.20	257.4	171.6	128.7	103.0
	40	6.00	297.0	198.0	148.9	84.0

* Nozzle or tip (TP). Tip used with the standard TeeJet® cap. Nozzles are threaded with BSPT threads.

** Use the conversion factor for other nozzle spacings.

Farm King



WARRANTY

WARRANTY215

Farm King



WARRANTY

Farm King

Limited Warranty

BASE LIMITED WARRANTY

Farm King provides this warranty only to original retail purchasers of its products. Farm King warrants to such purchasers that all Farm King manufactured parts and components used and serviced as provided for in the Operator's Manual shall be free from defects in materials and workmanship for a period following delivery to the original retail purchaser of one (1) year. This limited warranty applies only to those parts and components manufactured by Farm King. Parts and components manufactured by others are subject to their manufacturer's warranties, if any.

Farm King will fulfill this limited warranty by, at its option, repairing or replacing any covered part that is defective or is the result of improper workmanship, provided that the part is returned to Farm King within thirty (30) days of the date that such defect or improper workmanship is, or should have been, discovered. Parts must be returned through the selling representative and the buyer must prepay transportation charges.

Farm King will not be responsible for repairs or replacements that are necessitated, in whole or part, by the use of parts not manufactured by or obtained from Farm King. Under no circumstances are component parts warranted against normal wear and tear. There is no warranty on product pump seals, product pump bearings, rubber product hoses, pressure gauges, or other components that require replacement as part of normal maintenance.

REPAIR PARTS LIMITED WARRANTY

Farm King warrants genuine Farm King replacement parts purchased after the expiration of the Farm King Limited Warranty, and used and serviced as provided for in the Operator's Manual, to be free from defects in materials or workmanship for a period of thirty (30) days from the invoice date for the parts. Farm King will fulfill this limited warranty by, at its option, repairing or replacing any covered part that is defective or is the result of improper workmanship, provided that the part is returned to Farm King within thirty (30) days of the date that such defect or improper workmanship is, or should have been, discovered. Such parts must be shipped to the Farm King factory at the purchaser's expense.

WHAT IS NOT COVERED

Under no circumstances does this limited warranty cover any components or parts that have been subject to the following: negligence; alteration or modification not approved by Farm King; misuse; improper storage; lack of reasonable and proper maintenance, service, or repair; normal wear; damage from failure to follow operating instructions; accident; and/or repairs that have been made with parts other than those manufactured, supplied, and or authorized by Farm King.

AUTHORIZED DEALER AND LABOR COSTS

Repairs eligible for labor under this limited warranty must be made by Farm King or an authorized Farm King dealer. Farm King retains the exclusive discretion to determine whether it will pay labor costs for warranty repairs or replacements, and the amount of such costs that it will pay and the time in which the repairs will be made. If Farm King determines that it will pay labor costs for warranty work, it will do so by issuing a credit to the dealer's or distributor's account. Farm King will not approve or pay invoices sent for repairs that Farm King has not previously approved. Warranty service does not extend the original term of this limited warranty.

Farm King

Limited Warranty

WARRANTY REQUIREMENTS

To be covered by warranty, each new product must be registered with Farm King within thirty (30) days of delivery to original retail purchaser. If the customer decides to purchase replacement components before the warranty disposition of such components is determined, Farm King will bill the customer for such components and then credit the replacement invoice for those components later determined to be covered by this limited warranty. Any such replacement components that are determined not to be covered by this limited warranty will be subject to the terms of the invoice and shall be paid for by the purchaser.

EXCLUSIVE EFFECT OF WARRANTY AND LIMITATION OF LIABILITY

TO THE EXTENT PERMITTED BY LAW, FARM KING DISCLAIMS ANY WARRANTIES, REPRESENTATIONS, OR PROMISES, EXPRESS OR IMPLIED, AS TO THE QUALITY, PERFORMANCE, OR FREEDOM FROM DEFECT OF THE COMPONENTS AND PARTS COVERED BY THIS WARRANTY AND NOT SPECIFICALLY PROVIDED FOR HEREIN.

TO THE EXTENT PERMITTED BY LAW, FARM KING DISCLAIMS ANY IMPLIED WARRANTIES OF MERCHANTABILITY AND FITNESS FOR A PARTICULAR PURPOSE ON ITS PRODUCTS COVERED HEREIN, AND DISCLAIMS ANY RELIANCE BY THE PURCHASER ON FARM KING'S SKILL OR JUDGMENT TO SELECT OR FURNISH GOODS FOR ANY PARTICULAR PURPOSE. THE PURCHASER'S ONLY AND EXCLUSIVE REMEDIES IN CONNECTION WITH THE BREACH OR PERFORMANCE OF ANY WARRANTY ON FARM KING'S PRODUCTS ARE THOSE SET FORTH HEREIN. IN NO EVENT SHALL FARM KING BE LIABLE FOR INCIDENTAL OR CONSEQUENTIAL DAMAGES (INCLUDING, BY WAY OF EXAMPLE ONLY AND NOT LIMITATION, LOSS OF CROPS, LOSS OF PROFITS OR REVENUE, OTHER COMMERCIAL LOSSES, INCONVENIENCE, OR COST OF REPLACEMENT OF RENTAL EQUIPMENT). IN NO EVENT SHALL FARM KING'S CONTRACT OR WARRANTY LIABILITY EXCEED THE PURCHASE PRICE OF THE PRODUCT. (Note that some states do not allow limitations on how long an implied warranty lasts or the exclusion or limitation of incidental or consequential damages, so the above limitations and exclusion may not apply to you.) This warranty gives you specific legal rights and you may also have other rights, which vary from state to state.

Farm King neither assumes nor authorizes any person or entity, including its selling representatives, to assume any other obligations or liability in connections with the sale of covered equipment, or to make any other warranties, representations, or promises, express or implied, as to the quality, performance, or freedom from defect of the components and parts covered herein. No one is authorized to alter, modify, or enlarge this limited warranty, or its exclusions, limitations and reservations.

Corrections of defects and improper workmanship in the manner, and for the applicable time periods, provided for herein shall constitute fulfillment of all responsibilities of Farm King to the purchaser, and Farm King shall not be liable in negligence, contract, or on any other basis with respect to the subject equipment.

This limited warranty is subject to any existing conditions of supply which may directly affect Farm King's ability to obtain materials or manufacturer replacement parts.

Buhler Industries Inc. reserves the right to make improvements in design or changes in specifications to its products at anytime, without incurring any obligation to owners of units previously sold.

ALPHABETICAL INDEX

1 SECTION CONTROL VALVE ASSEMBLY . . . 138	HYDRAULIC CONNECTION SPECIFICATIONS 209
3 SECTION CONTROL VALVE ASSEMBLY . . . 140	HYDRAULIC FUNCTIONS 47
ACE PUMP & PLUMBING ASSEMBLY . . . 124	HYDRAULIC GROUP, W / INNER WINGS ONLY 182
ACE PUMP & PLUMBING SUB-ASSEMBLY . . . 126	HYDRAULIC GROUP, W/ INNER AND OUTER WINGS 184
ADJUSTABLE AXLE ASSEMBLY (OPTIONAL) 85	HYDRAULIC SCHEMATIC (W / INNER AND OUTER WINGS) 205
ADJUSTING HYDRAULIC PRESSURE . . . 71	HYDRAULIC SCHEMATIC (W / INNER WINGS ONLY) 204
AXLES 73	INITIAL SET-UP 42
CLEANING 75	INNER WING CYLINDER 198
COMPONENT INSTALLATION 29	ISOBUS (OPTIONAL) 192
COULTER ARM ASSEMBLY 170	JB MANIFOLD JUNCTION ASSEMBLY . . 142
COULTER BRACKET GROUP 149	JB TWIN PUMP PLUMBING ASSEMBLY (1 OF 3) 130
COULTER W/INJECTOR ASSEMBLY . . . 168	JB TWIN PUMP PLUMBING ASSEMBLY (2 OF 3) 132
DUAL AXLE ASSEMBLY - 20 / 22 86	JB TWIN PUMP PLUMBING ASSEMBLY (3 OF 3) 134
DUAL AXLE ASSEMBLY - 30 87	JOHN BLUE PUMP SETTING 55
DUAL AXLE ASSEMBLY - 38 88	JOHN BLUE SUB-ASSEMBLY 136
EQUIPMENT DECALS AND SIGNS 24	LIGHTING MARKING GROUP 180
EQUIPMENT IDENTIFICATION 10	LUBRICATION 68
FERTILIZER APPLICATOR OPERATION . . 45	MAIN LIFT CYLINDER 199
FIELD OPERATION 53	MARKING GROUP ASSEMBLY 179
FIRE PREVENTION 18	NOZZLE SELECTION 210
FRAME GROUP 90	NOZZLE SPECIFICATIONS 211
FRONT SIGHT GAUGE 100	OUTER WING CYLINDER 197
GAUGE WHEEL HUB 122	OWNER'S INFORMATION 9
GAUGE WHEEL 121	PRODUCT PUMP ASSEMBLY 128
GENERAL INFORMATION 39	QUICK FILL GROUP 145
GENERAL PARTS INFORMATION 83	RAVEN 450 (OPTIONAL) 190
HAND / EYE WASH GROUP 102	RAVEN PHOENIX 10 GPS (OPTIONAL) . . 196
HAND / EYE WASH TANK ASSEMBLY (CREAM) 103	RAVEN VIPER 4 W / GPS (OPTIONAL) . . 191
HARDWARE TORQUE VALUES 207	REAR SIGHT GAUGE 101
HITCH GROUP 92	RH 2996 FERT COULTER LIQUID KNIFE 164
HUB ASSEMBLY 89	RIPPLE COULTER W / INJECT GROUP . 163
HYDRAULIC / ELECTRICAL SCHEMATIC 206	RIPPLE COULTER W / KNIFE GROUP . . 172
HYDRAULIC BLOCK COMPONENTS 188	SAFETY INSTRUCTIONS 15
HYDRAULIC BLOCK 186	

SAFETY SIGN (DECAL) INSTALLATION	..76
SAFETY SIGN-OFF FORM25
SAFETY SIGNS (DECALS)21
SCS440 / 450 HARNESS ONLY (OPTIONAL) 194	
SERVICE SCHEDULE67
SIGHT GAUGE ASSEMBLY99
SINGLE AXLE ASSEMBLY - 120 IN.83
SINGLE AXLE ASSEMBLY 132 IN.84
SPECIFICATIONS203
STORAGE AND RETURN TO SERVICE	..77
SUMP MANIFOLD GROUP144
TANK ASSEMBLY97
TANK BAFFLE GROUP98
TANK SUPPORT FRONT95
TANK SUPPORT REAR96
TANK SUPPORT94
TIRE / WHEEL SINGLE 320 / 90 R50173
TIRE / WHEEL SINGLE 380 / 90 R46174
TIRE / WHEEL STRADDLE DUAL, 20 IN SPACING175
TIRE / WHEEL STRADDLE DUAL, 22 IN SPACING176
TIRE / WHEEL STRADDLE DUAL, 30 IN SPACING177
TIRE / WHEEL STRADDLE DUAL, 38 IN SP 178	
TOOLBAR ASSEMBLY (325 / 370 IN.)	...104
TOOLBAR ASSEMBLY (325 / 400.5 IN.)	..106
TOOLBAR ASSEMBLY (325 / 489.5 IN.)	..108
TOOLBAR ASSEMBLY (325 / 533 IN.)	...110
TOOLBAR ASSEMBLY (325 IN.)120
TOOLBAR ASSEMBLY (357 / 533 IN.)	...112
TOOLBAR ASSEMBLY (375 / 489.5 IN.)	..114
TOOLBAR ASSEMBLY (400 / 533 IN.)	...116
TOOLBAR BASE ASSEMBLY118
TOOLBAR GOOSE HOOK ASSEMBLY	..123
TOOLBAR PLUMBING GROUP146
TRANSPORTING60
TROUBLESHOOTING65
WARRANTY REGISTRATION FORM5
WARRANTY215

www.farm-king.com

Farm King

2500 Airport Drive SW
Willmar, MN USA 56201
Toll Free: 1-888-FK-80001
E-mail: info@buhler.com
www.farm-king.com

Equipment shown is subject to change without notice.
©2017 Buhler Trading Inc. Printed in the USA

bühler | a division of Buhler Industries Inc.